

HD75173

Quadruple Differential Line Receivers With 3 State Outputs

HITACHI

ADE-205-592 (Z)
1st. Edition
Dec. 2000

Description

The HD75173 is a quadruple differential line receiver with three state outputs. It is designed to satisfy the requirements of EIA standards RS-422A, RS-423A and several CCITT recommendations. Each receiver features an active high enable and an active low enable common to all four receivers. It also features differential input sensitivity of ± 200 mV.

Function Table

Differential Inputs A-B	Enables		Output Y
	G	\bar{G}	
$V_{ID} \geq 0.2$ V	H	X	H
	X	L	H
-0.2 V $< V_{ID} < 0.2$ V	H	X	?
	X	L	?
$V_{ID} \leq -0.2$ V	H	X	L
	X	L	L
X	L	H	Z

H : High level

L : Low level

X : Irrelevant

? : Indeterminate

Z : High impedance

Pin Arrangement

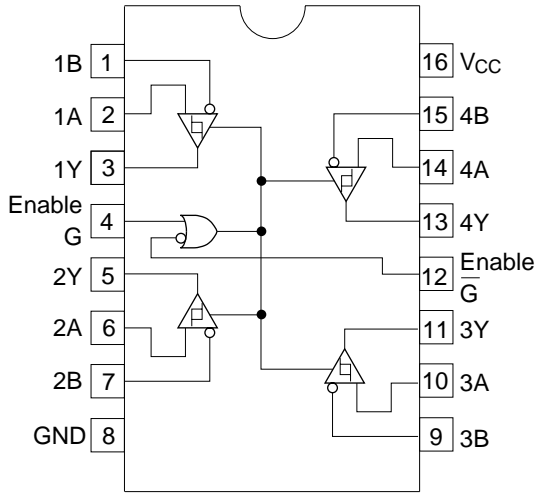

(Top view)

Absolute Maximum Ratings (Ta = 0 to 70°C)

Item	Symbol	Rating	Unit
Supply Voltage	V_{CC}	7	V
Input Voltage, A or B Inputs	V_{IN}	± 25	V
Differential Input Voltage* ¹	V_{ID}	± 25	V
Enable Input Voltage	V_{IE}	7	V
Output Current	I_{OL}	50	mA
Power Dissipation (Ta = 25°C)	P_T	1150	mW
Operating temperature range	Topr	0 to 70	°C
Storage Temperature Range	Tstg	-65 to +150	°C

- Notes: 1. Differential input voltage is measured at the noninverting input with respect to the corresponding inverting input
2. The absolute maximum ratings are values which must not individually be exceeded, and furthermore, no two of which may be realized at the same time.

Recommended Operating Conditions

Item	Symbol	Min	Typ	Max	Unit
Supply Voltage	V_{CC}	4.75	5.00	5.25	V
Common Mode Input Voltage	V_{IN}	—	—	±12	V
Differential Input Voltage	V_{ID}	—	—	±12	V
Output Current	V_{OH}	—	—	-400	μA
	V_{OL}	—	—	16	mA
Operating Temperature	T_{opr}	0	—	70	°C

DC Electrical Characteristics ($T_a = 0$ to 70°C)

Item	Symbol	Min	Typ *1	Max	Unit	Conditions
Differential Input High Threshold Voltage	V_{TH}	—	—	0.2	V	$V_O = 2.7\text{ V}$, $I_O = -0.4\text{ mA}$
Differential Output Low Threshold Voltage	V_{TL}	-0.2*2	—	—	V	$V_O = 0.5\text{ V}$, $I_O = 16\text{ mA}$
Hysteresis	$V_T^+ - V_T^-$	—	50	—	mV	
Enable Input Voltage	V_{IH}	2	—	—	V	
	V_{IL}	—	—	0.8		
Enable Input Clamp Voltage	V_{IK}	—	—	-1.5	V	$I_I = -18\text{ mA}$
Output Voltage	V_{OH}	2.7	—	—	V	$V_{ID} = 200\text{ mV}$, $I_{OH} = -400\text{ μA}$
	V_{OL}	—	—	0.45	V	$V_{ID} = -200\text{ mV}$, $I_{OL} = 8\text{ mA}$
		—	—	0.5		$V_{ID} = -200\text{ mV}$, $I_{OL} = 16\text{ mA}$
High Impedance State Output Current	V_{OZ}	—	—	-20	μA	$V_O = 0.4\text{ V}$
		—	—	+20		$V_O = 2.4\text{ V}$
Line Input Current	I_I	—	—	1	mA	Other Input at 0 V^{*4} $V_I = 12\text{ V}$ $V_I = -7\text{ V}$
		—	—	-0.8		
Enable Input Current	I_{IH}	—	—	20	μA	$V_{IH} = 2.7\text{ V}$
	I_{IL}	—	—	-100	μA	$V_{IL} = 0.4\text{ V}$
Input Resistance	r_i	12	—	—	kΩ	
Short Circuit Output Current*3	I_{OS}	-15	—	-85	mA	
Supply Current	I_{CC}	—	—	70	mA	

Notes: 1. All Typical Values are at $V_{CC} = 5\text{ V}$, $T_a = 25^\circ\text{C}$

2. The algebraic convention is used in this data sheet for threshold voltage levels only.

3. Not more than one output should be shorted at a time.

4. Refer to EIA standards RS-422A and RS-423A for exact conditions.

Switching Characteristics ($V_{CC} = 5\text{ V}$, $T_a = 25^\circ\text{C}$)

Item	Symbol	Min	Typ	Max	Unit	Test Conditions
Propagation Delay Time	t_{PLH}	—	20	35	ns	$C_L = 15\text{ pF}$
	t_{PHL}	—	22	35		
Output Enable Time	t_{ZH}	—	17	22		$C_L = 15\text{ pF}$
	t_{ZL}	—	20	25		
Output Disable Time	t_{HZ}	—	21	30		$C_L = 5\text{ pF}$
	t_{LZ}	—	30	40		

Switching Time Test Method

1. t_{PLH} , t_{PHL}

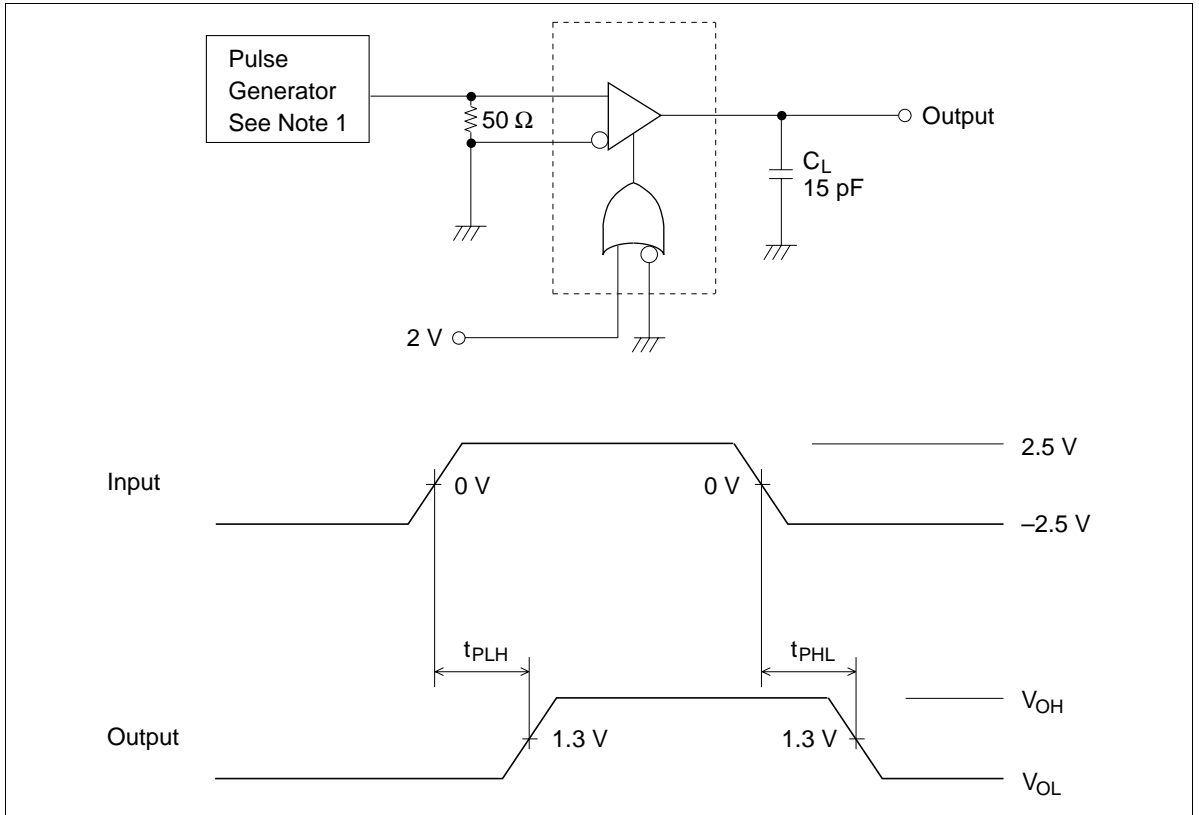

2. t_{ZH} , t_{ZL}

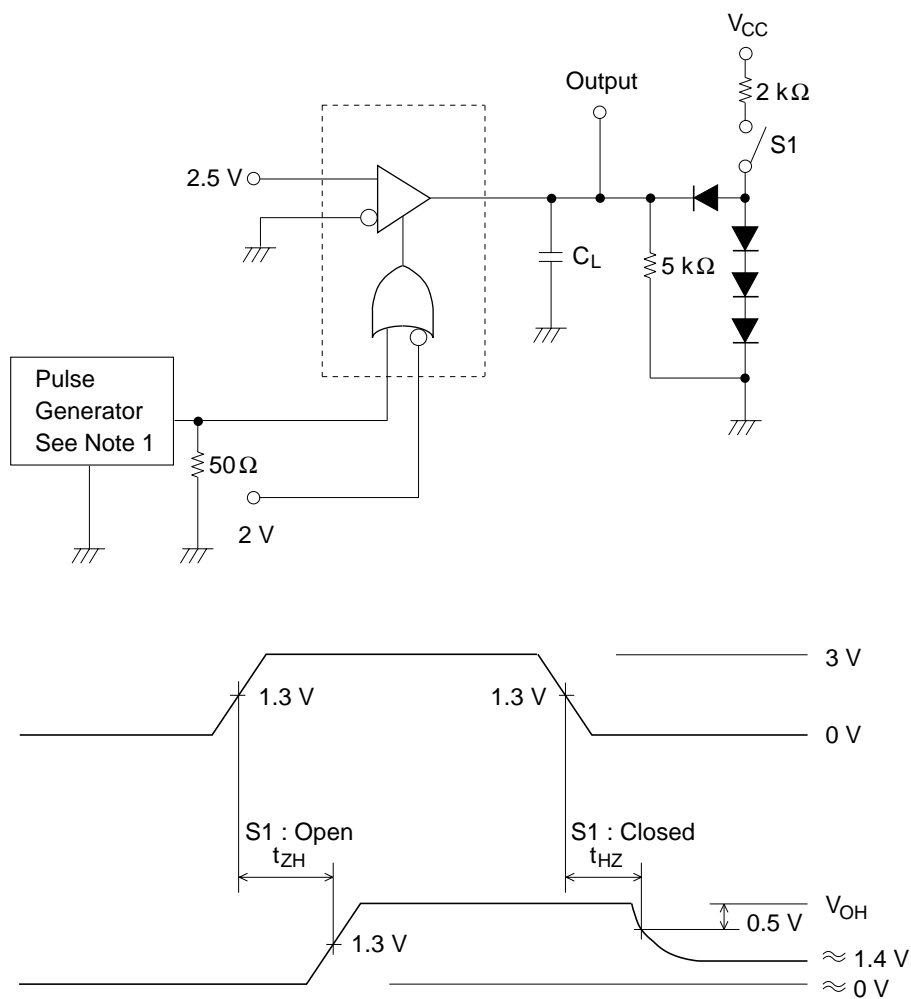

3. t_{ZL} , t_{LZ}

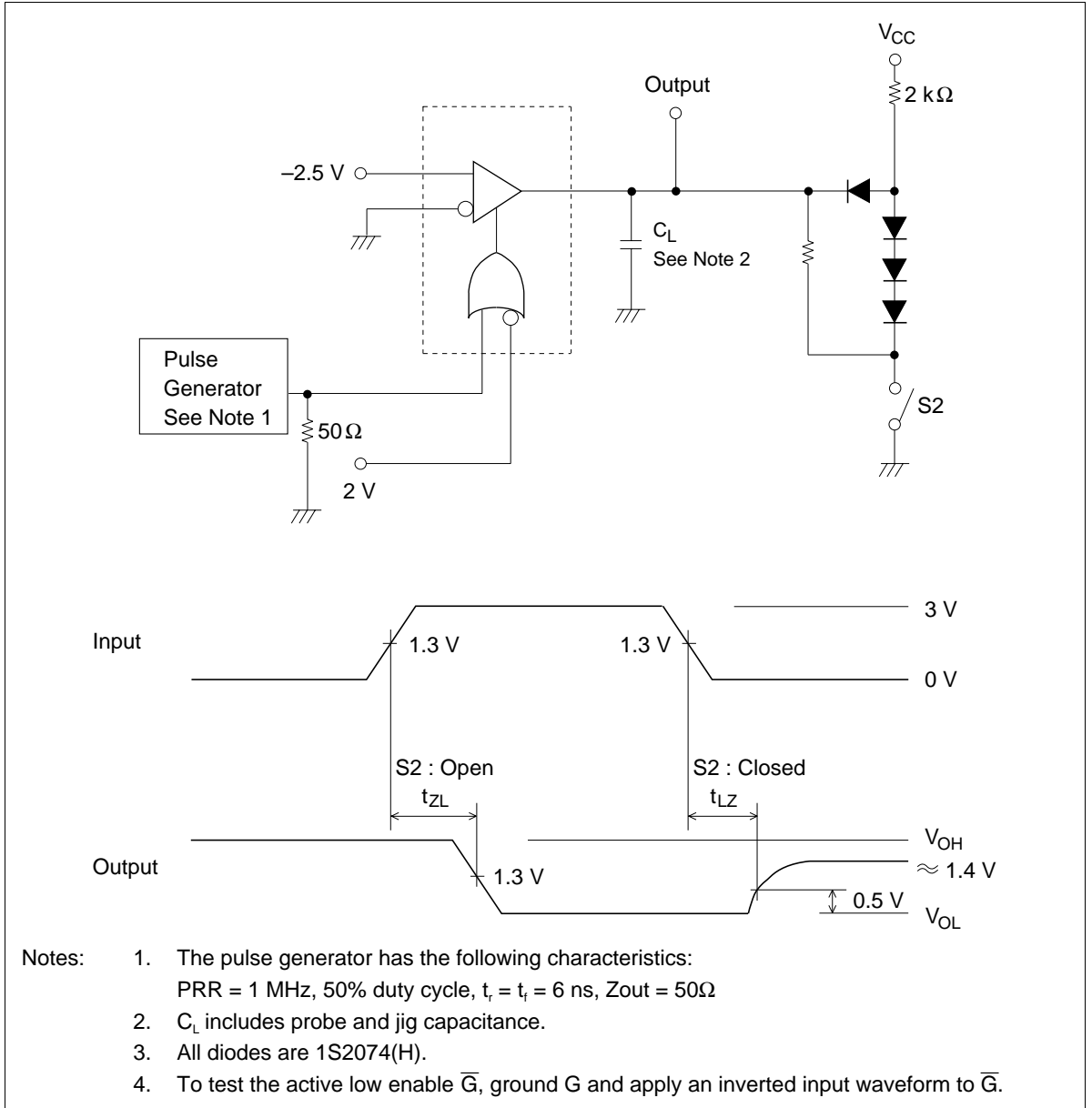

Package Dimensions

Unit: mm

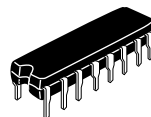
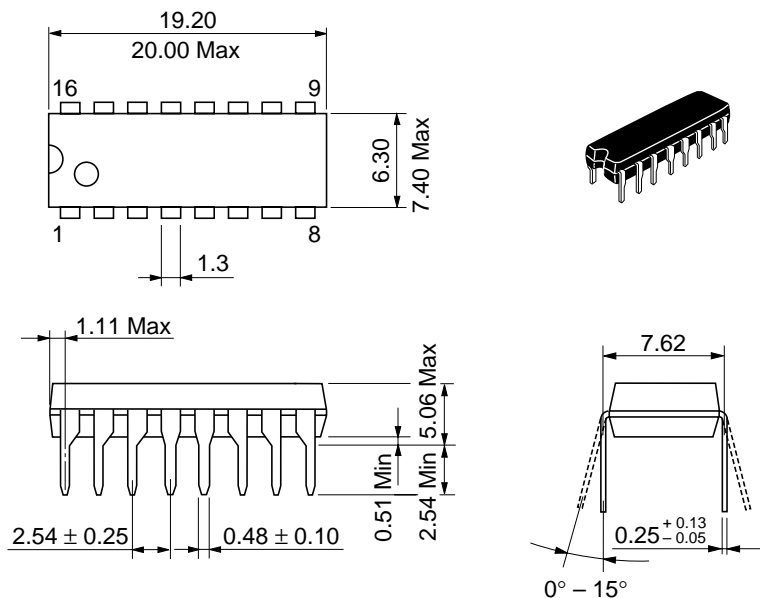

Hitachi Code	DP-16
JEDEC	Conforms
EIAJ	Conforms
Mass (reference value)	1.07 g

Cautions

1. Hitachi neither warrants nor grants licenses of any rights of Hitachi's or any third party's patent, copyright, trademark, or other intellectual property rights for information contained in this document. Hitachi bears no responsibility for problems that may arise with third party's rights, including intellectual property rights, in connection with use of the information contained in this document.
2. Products and product specifications may be subject to change without notice. Confirm that you have received the latest product standards or specifications before final design, purchase or use.
3. Hitachi makes every attempt to ensure that its products are of high quality and reliability. However, contact Hitachi's sales office before using the product in an application that demands especially high quality and reliability or where its failure or malfunction may directly threaten human life or cause risk of bodily injury, such as aerospace, aeronautics, nuclear power, combustion control, transportation, traffic, safety equipment or medical equipment for life support.
4. Design your application so that the product is used within the ranges guaranteed by Hitachi particularly for maximum rating, operating supply voltage range, heat radiation characteristics, installation conditions and other characteristics. Hitachi bears no responsibility for failure or damage when used beyond the guaranteed ranges. Even within the guaranteed ranges, consider normally foreseeable failure rates or failure modes in semiconductor devices and employ systemic measures such as fail-safes, so that the equipment incorporating Hitachi product does not cause bodily injury, fire or other consequential damage due to operation of the Hitachi product.
5. This product is not designed to be radiation resistant.
6. No one is permitted to reproduce or duplicate, in any form, the whole or part of this document without written approval from Hitachi.
7. Contact Hitachi's sales office for any questions regarding this document or Hitachi semiconductor products.

HITACHI

Hitachi, Ltd.

Semiconductor & Integrated Circuits.
Nippon Bldg., 2-6-2, Ohte-machi, Chiyoda-ku, Tokyo 100-0004, Japan
Tel: Tokyo (03) 3270-2111 Fax: (03) 3270-5109

URL North America : <http://semiconductor.hitachi.com/>
 Europe : <http://www.hitachi-eu.com/hel/ecg>
 Asia : <http://sicapac.hitachi-asia.com>
 Japan : <http://www.hitachi.co.jp/Sicd/indx.htm>

For further information write to:

Hitachi Semiconductor
(America) Inc.
179 East Tasman Drive,
San Jose, CA 95134
Tel: <1> (408) 433-1990
Fax: <1> (408) 433-0223

Hitachi Europe GmbH
Electronic Components Group
Dornacher StraÙe 3
D-85622 Feldkirchen, Munich
Germany
Tel: <49> (89) 9 9180-0
Fax: <49> (89) 9 29 30 00

Hitachi Europe Ltd.
Electronic Components Group.
Whitebrook Park
Lower Cookham Road
Maidenhead
Berkshire SL6 8YA, United Kingdom
Tel: <44> (1628) 585000
Fax: <44> (1628) 585160

Hitachi Asia Ltd.
Hitachi Tower
16 Collyer Quay #20-00,
Singapore 049318
Tel: <65>-538-6533/538-8577
Fax : <65>-538-6933/538-3877
URL : <http://www.hitachi.com.sg>

Hitachi Asia Ltd.
(Taipei Branch Office)
4/F, No. 167, Tun Hwa North Road,
Hung-Kuo Building,
Taipei (105), Taiwan
Tel: <886>-(2)-2718-3666
Fax : <886>-(2)-2718-8180
Telex : 23222 HAS-TP
URL : <http://www.hitachi.com.tw>

Hitachi Asia (Hong Kong) Ltd.
Group III (Electronic Components)
7/F., North Tower,
World Finance Centre,
Harbour City, Canton Road
Tsim Sha Tsui, Kowloon,
Hong Kong
Tel : <852>-(2)-735-9218
Fax : <852>-(2)-730-0281
URL : <http://www.hitachi.com.hk>

Copyright © Hitachi, Ltd., 2000. All rights reserved. Printed in Japan.
Colophon 2.0

HITACHI