

Features

- -100V/-25A,
 $R_{DS(ON)} = 40m$ (typ.)@ $V_{GS} = -10V$
- Super High Dense Cell Design
- Ultra Low On-Resistance
- Reliable and Rugged
- 100% avalanche tested
- Lead Free and Green Devices Available
 (RoHS Compliant)

Applications

- Inverters

Pin Description

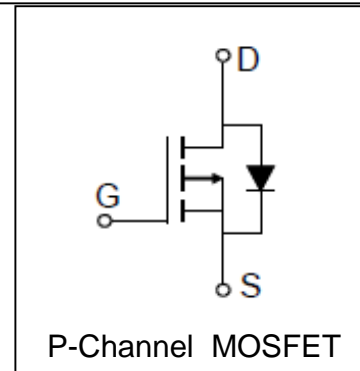
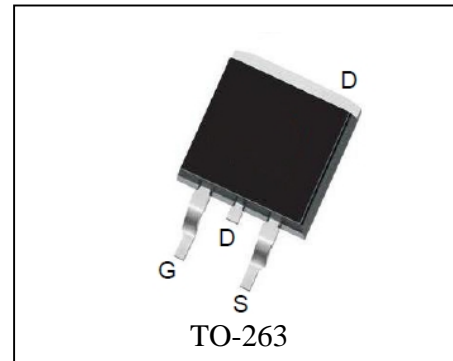

Absolute Maximum Ratings

| Symbol | Parameter | Rating | Unit |
|--|--|---|--------------|
| Common Ratings ($T_C = 25^\circ C$ Unless Otherwise Noted) | | | |
| V_{DSS} | Drain-Source Voltage | -100 | V |
| V_{GSS} | Gate-Source Voltage | ± 20 | |
| T_J | Maximum Junction Temperature | 175 | $^\circ C$ |
| T_{STG} | Storage Temperature Range | -55 to 175 | $^\circ C$ |
| I_S | Diode Continuous Forward Current | $T_C = 25^\circ C$ -25 | A |
| Mounted on Large Heat Sink | | | |
| I_{DP} | 300 μs Pulse Drain Current Tested | $T_C = 25^\circ C$ -100 ^① | A |
| I_D | Continuous Drain Current ($V_{GS} = -10V$) | $T_C = 25^\circ C$ -25 ^② | A |
| | | $T_C = 100^\circ C$ -19 | |
| P_D | Maximum Power Dissipation | $T_C = 25^\circ C$ 79 | W |
| | | $T_C = 100^\circ C$ 39.5 | |
| $R_{\theta JC}$ | Thermal Resistance-Junction to Case | 1.9 | $^\circ C/W$ |
| Drain-Source Avalanche Ratings | | | |
| E_{AS} ^③ | Avalanche Energy, Single Pulsed | 132 | mJ |

Electrical Characteristics ($T_C=25^\circ\text{C}$ Unless Otherwise Noted)

| Symbol | Parameter | Test Condition | RU1HP25S | | | Unit |
|---|----------------------------------|---|----------|------|-----------|------------|
| | | | Min. | Typ. | Max. | |
| Static Characteristics | | | | | | |
| BV_{DSS} | Drain-Source Breakdown Voltage | $V_{GS}=0V, I_{DS}=-250\mu A$ | -100 | | | V |
| I_{DSS} | Zero Gate Voltage Drain Current | $V_{DS}=-100V, V_{GS}=0V$ $T_J=85^\circ\text{C}$ | | | -1 -30 | μA |
| $V_{GS(th)}$ | Gate Threshold Voltage | $V_{DS}=V_{GS}, I_{DS}=-250\mu A$ | -2 | -3 | -4 | V |
| I_{GSS} | Gate Leakage Current | $V_{GS}=\pm 20V, V_{DS}=0V$ | | | ± 100 | nA |
| $R_{DS(ON)}^{(4)}$ | Drain-Source On-state Resistance | $V_{GS}=-10V, I_{DS}=-25A$ | | 40 | 60 | m Ω |
| Diode Characteristics | | | | | | |
| $V_{SD}^{(4)}$ | Diode Forward Voltage | $I_{SD}=-25A, V_{GS}=0V$ | | | -1.2 | V |
| t_{rr} | Reverse Recovery Time | $I_{SD}=-25A, dI_{SD}/dt=100A/\mu s$ | | 80 | | ns |
| Q_{rr} | Reverse Recovery Charge | | | 150 | | nC |
| Dynamic Characteristics ⁽⁵⁾ | | | | | | |
| R_G | Gate Resistance | $V_{GS}=0V, V_{DS}=0V, F=1\text{MHz}$ | | 2 | | Ω |
| C_{iss} | Input Capacitance | $V_{GS}=0V,$ | | 1500 | | pF |
| C_{oss} | Output Capacitance | $V_{DS}=-50V,$ | | 170 | | |
| C_{rss} | Reverse Transfer Capacitance | Frequency=1.0MHz | | 85 | | |
| $t_{d(ON)}$ | Turn-on Delay Time | | | 13 | | ns |
| t_r | Turn-on Rise Time | $V_{DD}=-50V, R_L=2\Omega,$ | | 36 | | |
| $t_{d(OFF)}$ | Turn-off Delay Time | $I_{DS}=-25A, V_{GEN}=-10V,$ | | 101 | | |
| t_f | Turn-off Fall Time | $R_G=6\Omega$ | | 68 | | |
| Gate Charge Characteristics ⁽⁵⁾ | | | | | | |
| Q_g | Total Gate Charge | | | 30 | | nC |
| Q_{gs} | Gate-Source Charge | $V_{DS}=-80V, V_{GS}=-10V,$ | | 8 | | |
| Q_{gd} | Gate-Drain Charge | $I_{DS}=-25A$ | | 11 | | |

- Notes: ① Pulse width limited by safe operating area.
 ② Calculated continuous current based on maximum allowable junction temperature.
 ③ Limited by $T_{Jmax}, I_{AS}=23A, V_{DD}=-60V, R_G=50\Omega$, Starting $T_J=25^\circ\text{C}$.
 ④ Pulse test; Pulse width $\leq 300\mu s$, duty cycle $\leq 2\%$.
 ⑤ Guaranteed by design, not subject to production testing.

Typical Characteristics

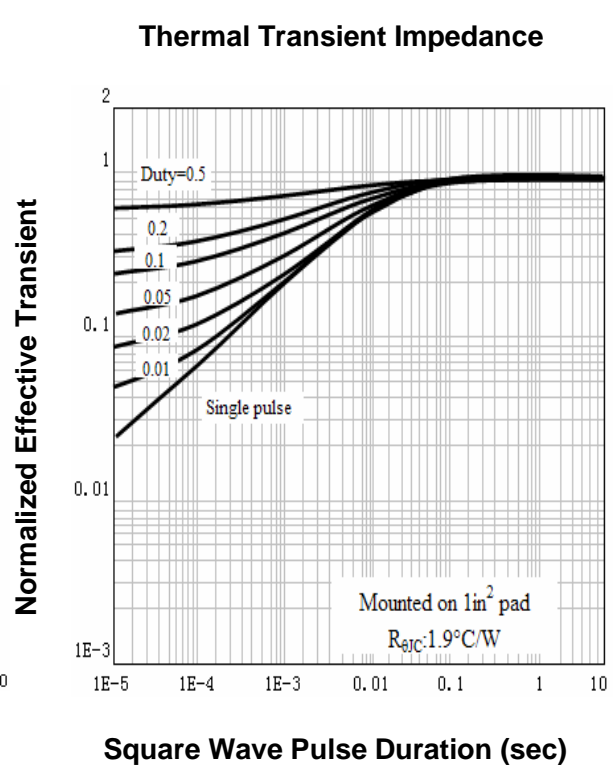
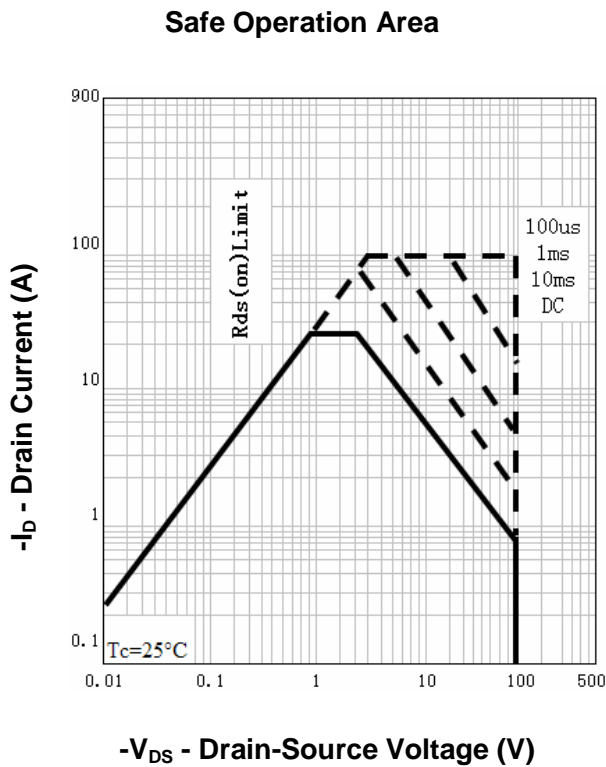
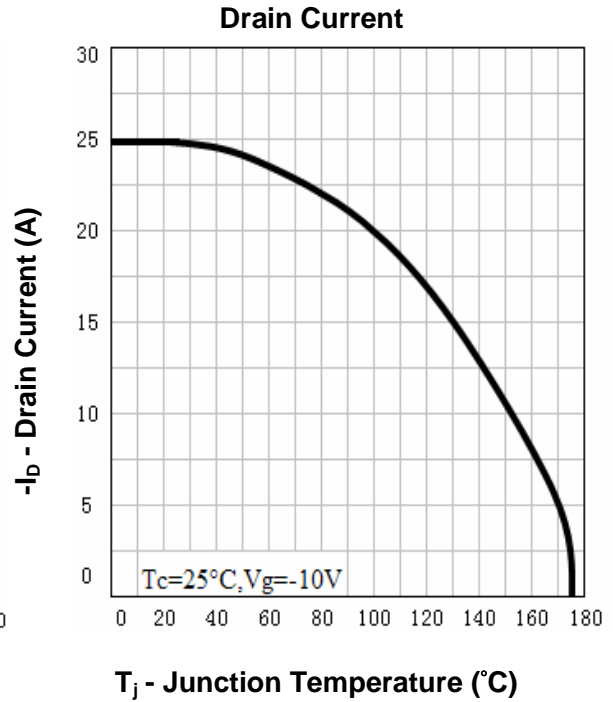
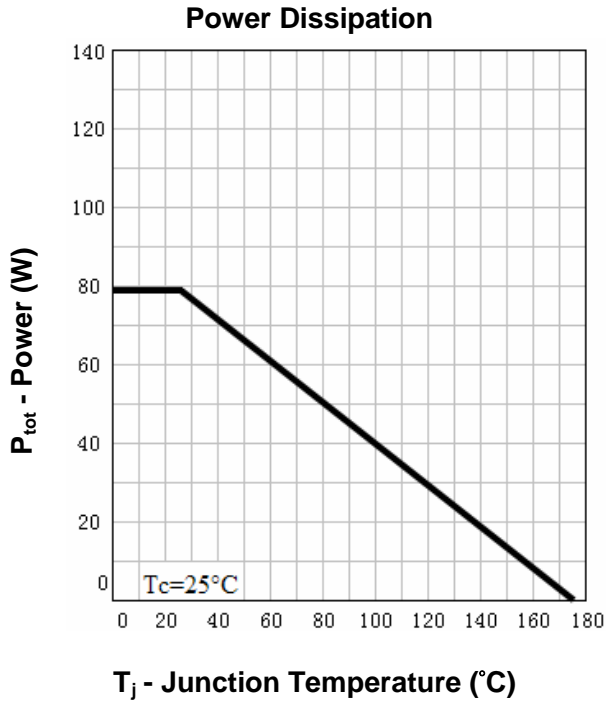

Typical Characteristics

Output Characteristics

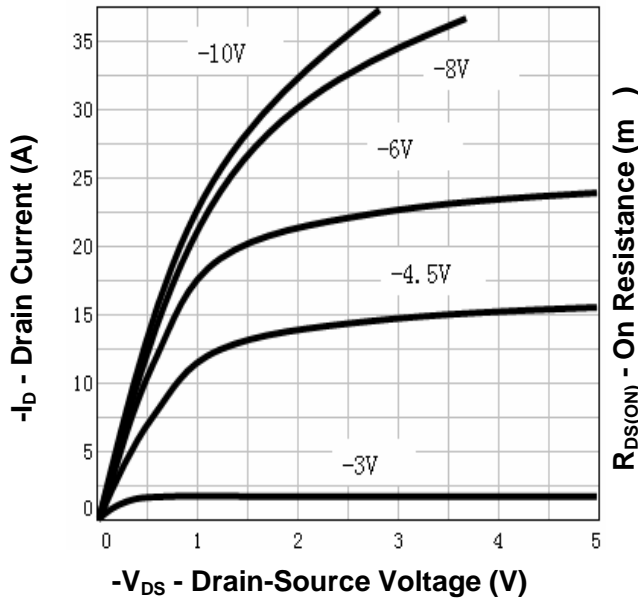

Drain-Source On Resistance

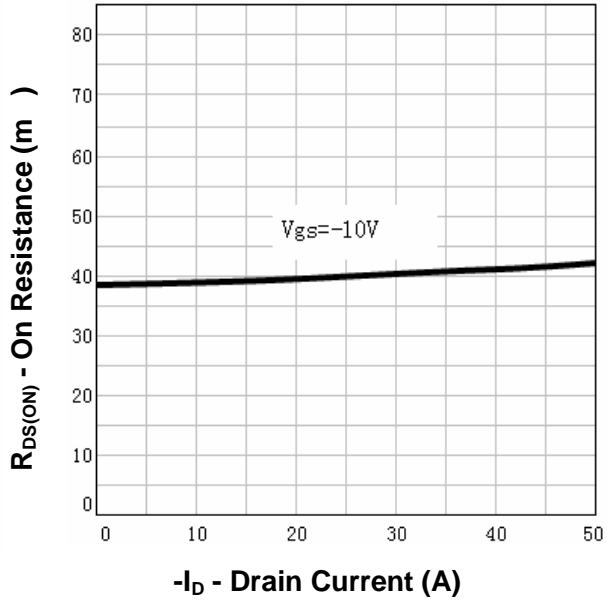

Drain-Source On Resistance

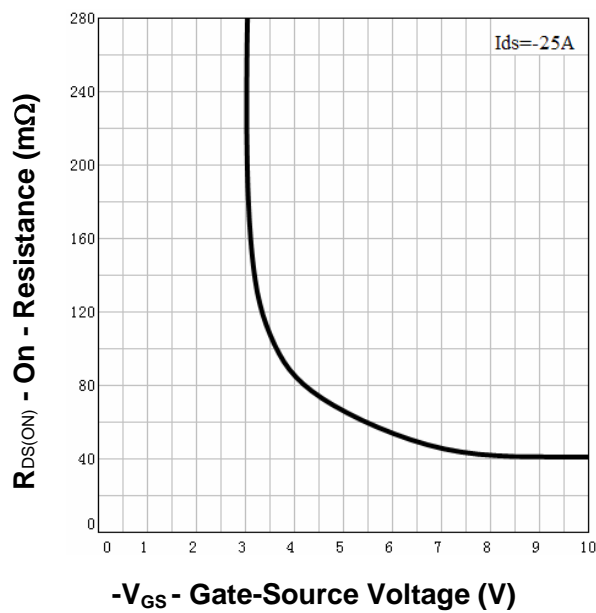

Gate Threshold Voltage

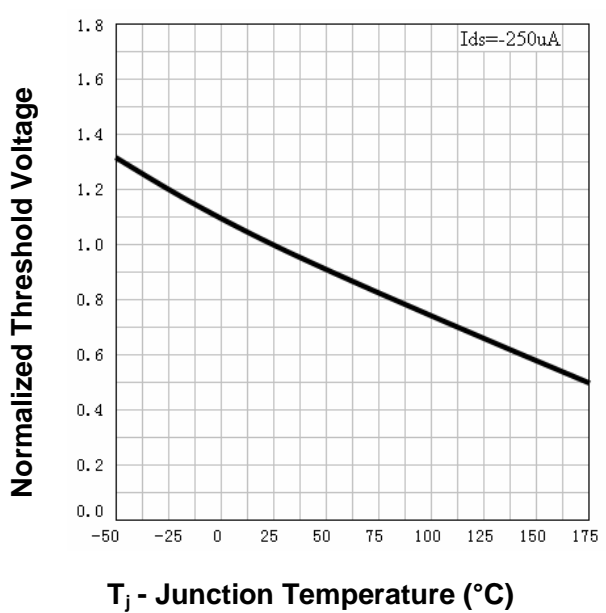

Typical Characteristics

Drain-Source On Resistance

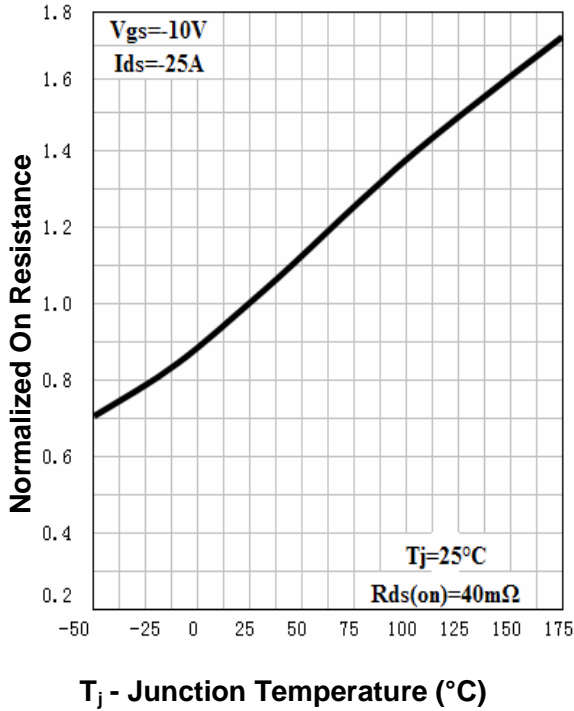

Source-Drain Diode Forward

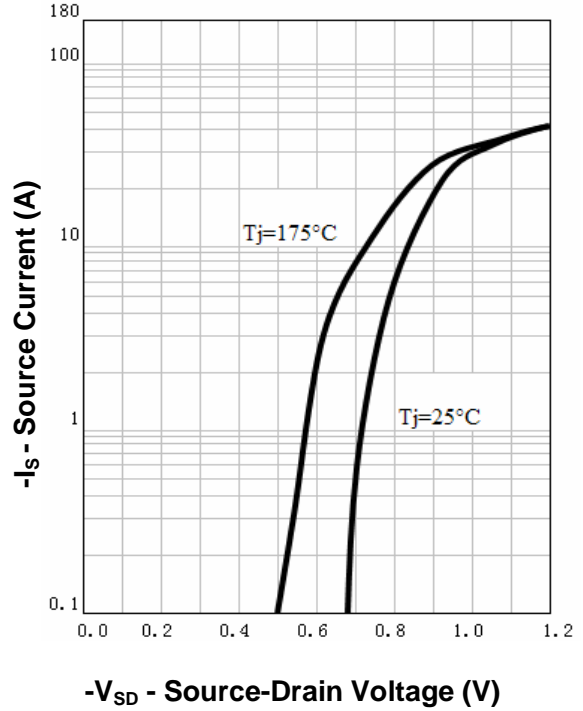

Capacitance

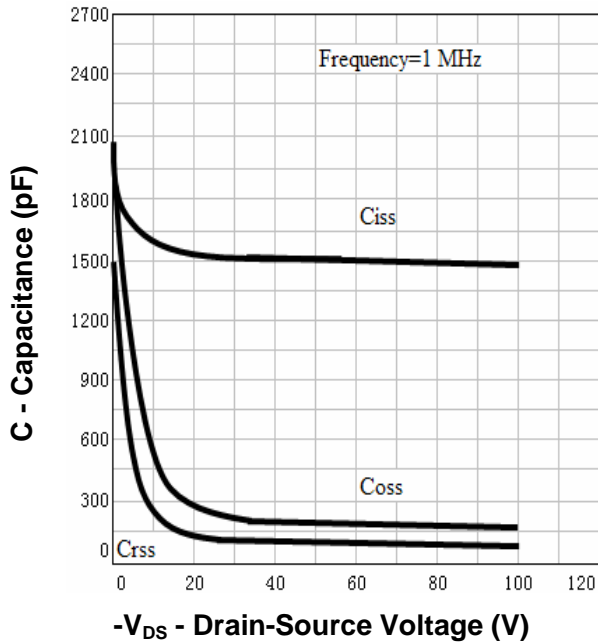

Gate Charge

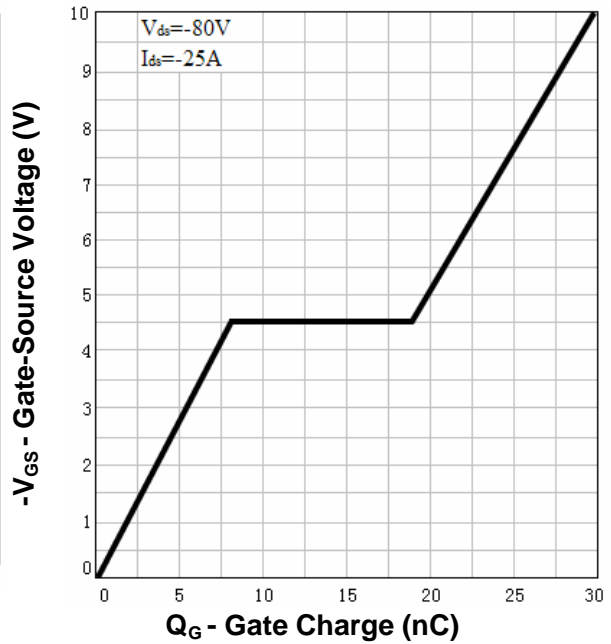

Avalanche Test Circuit and Waveforms

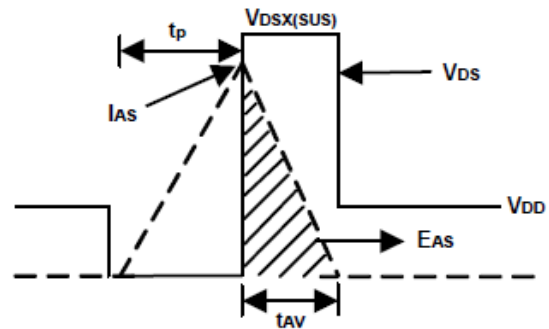
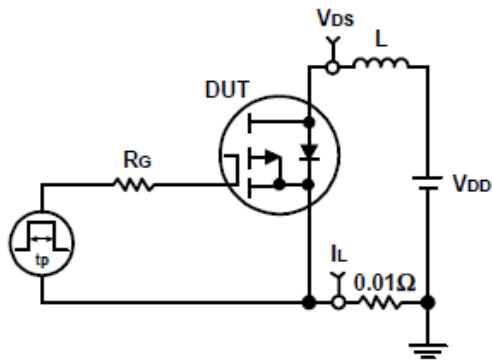

Switching Time Test Circuit and Waveforms

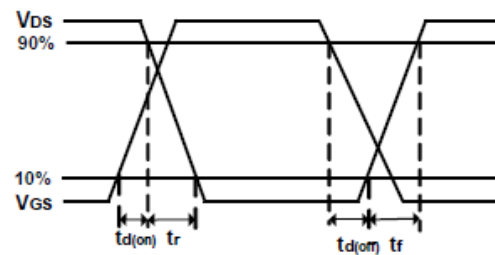
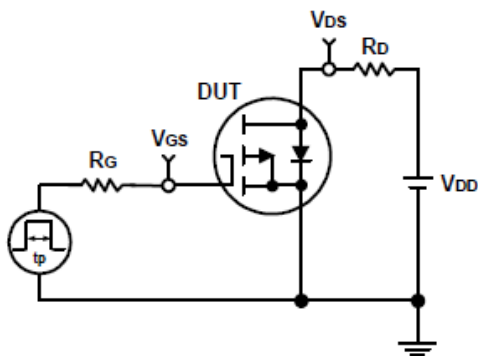

Ordering and Marking Information

| Device | Marking | Package | Packaging | Quantity | Reel Size | Tape width |
|---------------|----------------|----------------|------------------|-----------------|------------------|-------------------|
| RU1HP25S | RU1HP25S | TO-263 | Tube | 50 | - | - |

Package Information

TO-263-2L

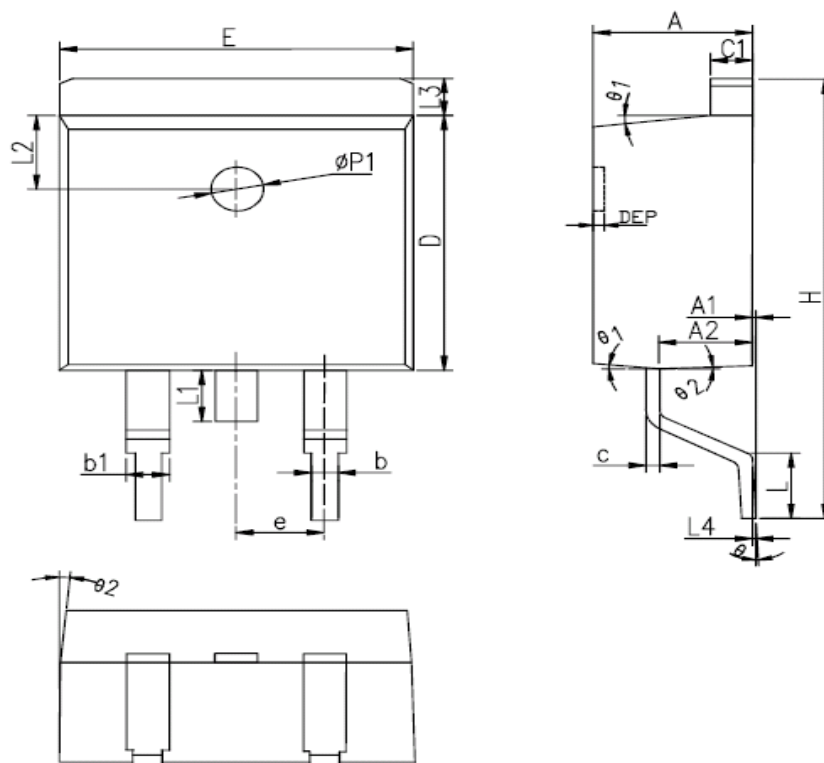

| SYMBOL | MM | | | INCH | | | SYMBOL | MM | | | INCH | | |
|--------|---------|-------|-------|--------|-------|-------|--------|----------|------|------|-----------|-------|-------|
| | MIN | NOM | MAX | MIN | NOM | MAX | | MIN | NOM | MAX | MIN | NOM | MAX |
| A | 4.40 | 4.57 | 4.70 | 0.173 | 0.180 | 0.185 | L | 2.00 | 2.30 | 2.60 | 0.079 | 0.090 | 0.102 |
| A1 | 0 | 0.10 | 0.25 | 0 | 0.004 | 0.010 | L3 | 1.17 | 1.27 | 1.40 | 0.046 | 0.050 | 0.055 |
| A2 | 2.59 | 2.69 | 2.79 | 0.102 | 0.106 | 0.110 | L1 | - | - | 1.70 | - | - | 0.067 |
| b | 0.77 | - | 0.90 | 0.030 | - | 0.035 | L4 | 0.25BSC | | | 0.01BSC | | |
| b1 | 1.23 | - | 1.36 | 0.048 | - | 0.052 | L2 | 2.50REF. | | | 0.098REF. | | |
| c | 0.34 | - | 0.47 | 0.013 | - | 0.019 | θ | 0° | - | 8° | 0° | - | 8° |
| C1 | 1.22 | - | 1.32 | 0.048 | - | 0.052 | θ 1 | 5° | 7° | 9° | 5° | 7° | 9° |
| D | 8.60 | 8.70 | 8.80 | 0.338 | 0.343 | 0.346 | θ 2 | 1° | 3° | 5° | 1° | 3° | 5° |
| E | 10.00 | 10.16 | 10.26 | 0.394 | 0.4 | 0.404 | DEP | 0.05 | 0.10 | 0.20 | 0.002 | 0.004 | 0.008 |
| e | 2.54BSC | | | 0.1BSC | | | Øp1 | 1.40 | 1.50 | 1.60 | 0.055 | 0.059 | 0.063 |
| H | 14.70 | 15.10 | 15.50 | 0.579 | 0.594 | 0.610 | | | | | | | |

ALL DIMENSIONS REFER TO JEDEC STANDARD
DO NOT INCLUDE MOLD FLASH OR PROTRUSIONS

Customer Service

Worldwide Sales and Service:

Sales@ruichips.com

Technical Support:

Technical@ruichips.com

Investor Relations Contacts:

Investor@ruichips.com

Marcom Contact:

Marcom@ruichips.com

Editorial Contact:

Editorial@ruichips.com

HR Contact:

HR@ruichips.com

Legal Contact:

Legal@ruichips.com

Shen Zhen RUICHIPS Semiconductor CO., LTD

Room 501, the 5floor An Tong Industrial Building,
NO.207 Mei Hua Road Fu Tian Area Shen Zhen City, CHINA

TEL: (86-755) 8311-5334

FAX: (86-755) 8311-4278

E-mail: Sales-SZ@ruichips.com