



**austriamicrosystems AG**

**is now**

**ams AG**

The technical content of this austriamicrosystems datasheet is still valid.

**Contact information:**

**Headquarters:**

ams AG

Tobelbaderstrasse 30

8141 Unterpremstaetten, Austria

Tel: +43 (0) 3136 500 0

e-Mail: [ams\\_sales@ams.com](mailto:ams_sales@ams.com)

Please visit our website at [www.ams.com](http://www.ams.com)

# AS5048A/AS5048B

Datasheet

Magnetic Rotary Encoder  
14-bit Angular Position Sensor

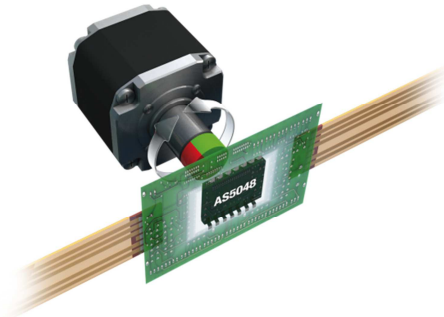

## General Description

The AS5048 is an easy to use 360° angle position sensor with a 14-bit high resolution output. The maximum system accuracy is 0.05° assuming linearization and averaging is done by the external microcontroller. The IC measures the absolute position of the magnet's rotation angle and consists of Hall sensors, analog digital converter and digital signal processing. The zero position can be programmed via SPI or I<sup>2</sup>C command. Therefore no programmer is needed anymore. This simplifies the assembly of the complete system because the zero position of the magnet does not need to be mechanically aligned. This helps developers to shorten their developing time. The sensor tolerates misalignment, air gap variations, temperature variations and as well external magnetic fields. This robustness and wide temperature range (-40°C up to +150°C) of the AS5048 makes the IC ideal for rotation angle sensing in harsh industrial and medical environments. Several AS5048 ICs can be connected in daisy chain for serial data read out. The absolute position information of the magnet is directly accessible over a PWM output and can be read out over a standard SPI or a high speed I<sup>2</sup>C interface. AS5048A has a SPI interface, AS5048B I<sup>2</sup>C interface. Both devices offer a PWM output. An internal voltage regulator allows the AS5048 to operate at either 3.3 V or 5 V supplies.

## Key Features & Benefits

- 360° contactless angle position sensor
- Standard SPI or high speed I<sup>2</sup>C interface
- Pulse width modulated output (PWM)
- Simple programmable zero position via SPI or I<sup>2</sup>C command
- No programmer needed
- 14-bit full scale resolution  
0.0219°/LSB
- Angle accuracy 0.05° after system linearization and averaging
- Daisy chain capability
- Tolerant to air gap variations  
magnetic field input range: 30mT – 70mT
- -40°C to +150°C ambient temperature range
- 3.3V / 5V compliant
- 14-pin TSSOP package (5x6.4mm)

## Applications

- Robotic joint position detection
- Industrial motor position control
- Medical robots and fitness equipment

## Block Diagram

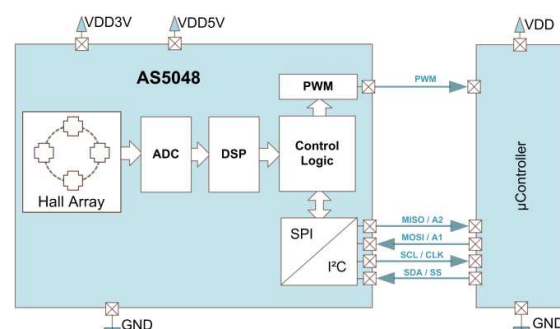

# AS5048A/AS5048B

Datasheet

Magnetic Rotary Encoder  
14-bit Angular Position Sensor

## Contents

<b>GENERAL DESCRIPTION .....</b>	<b>1</b>
KEY FEATURES & BENEFITS .....	1
APPLICATIONS .....	1
BLOCK DIAGRAM .....	1
<b>1 PIN CONFIGURATION .....</b>	<b>5</b>
1.1 PIN DESCRIPTION .....	5
<b>2 ELECTRICAL CHARACTERISTICS .....</b>	<b>6</b>
2.1 ABSOLUTE MAXIMUM RATINGS .....	6
2.2 OPERATING CONDITIONS .....	7
2.3 DC/AC CHARACTERISTICS FOR DIGITAL INPUTS AND OUTPUTS .....	7
2.4 ELECTRICAL SYSTEM SPECIFICATIONS .....	8
2.5 GLOBAL TIMING CONDITIONS .....	8
<b>3 FUNCTIONAL DESCRIPTION.....</b>	<b>9</b>
<b>4 OPERATION .....</b>	<b>9</b>
4.1 SUPPLY VOLTAGE CONFIGURATION .....	9
4.2 SPI INTERFACE .....	10
4.2.1 SPI Interface Signals (4-Wire Mode, Wire_mode = 1).....	10
4.2.2 SPI Timing .....	11
4.2.3 SPI Connection to the Host UC .....	12
4.2.4 SPI Communication Command Package .....	13
4.2.5 Read Package (Value Read from AS5048A) .....	14
4.2.6 Write Data Package (Value Written to AS5048A).....	14
4.2.7 Register Map SPI .....	15
4.2.8 SPI Interface Commands .....	16
4.3 I <sup>2</sup> C INTERFACE .....	19
4.3.1 I <sup>2</sup> C Electrical Specification .....	19
4.3.2 I <sup>2</sup> C Timing .....	20
4.3.3 Register Table .....	21
4.3.4 I <sup>2</sup> C Slave address .....	22
4.4 PWM INTERFACE .....	22
<b>5 PACKAGE DRAWINGS AND MARKINGS .....</b>	<b>23</b>
5.1.1 Assembly Lot Code .....	23
<b>6 APPLICATION INFORMATION .....</b>	<b>25</b>
6.1 PROGRAMMING OF THE AS5048 .....	25
6.1.1 Programming of the zero position .....	25
6.1.2 Programming sequence with verification.....	25
6.2 DIAGNOSTIC FUNCTIONS OF THE AS5048 .....	25

# AS5048A/AS5048B

Datasheet

Magnetic Rotary Encoder  
14-bit Angular Position Sensor

6.3	CHOOSING THE PROPER MAGNET .....	26
6.4	PHYSICAL PLACEMENT OF THE MAGNET .....	27
6.5	MAGNET PLACEMENT .....	27
<b>7</b>	<b>ORDERING INFORMATION .....</b>	<b>28</b>
<b>8</b>	<b>REVISION HISTORY .....</b>	<b>28</b>
<b>9</b>	<b>COPYRIGHTS.....</b>	<b>29</b>
<b>10</b>	<b>DISCLAIMER .....</b>	<b>29</b>

## List of Figures

FIGURE 1:	PIN CONFIGURATION TSSOP14.....	5
FIGURE 2:	CONNECTIONS FOR 5V AND 3.3V SUPPLY VOLTAGES .....	9
FIGURE 3	SPI CONNECTION AS5048A WITH UC .....	10
FIGURE 4	SPI COMMAND/RESPONSE DATA FLOW .....	10
FIGURE 5	SPI TIMING DIAGRAM.....	11
FIGURE 6	SINGLE SLAVE MODE.....	12
FIGURE 7	MULTIPLE SLAVE, N+3 WIRE (SEPARATE CHIPSELECT).....	12
FIGURE 8	DAISY CHAIN, 4 WIRE .....	13
FIGURE 9	READ COMMAND.....	16
FIGURE 10	WRITE COMMAND .....	16
FIGURE 11	CLEAR ERROR FLAG COMMAND.....	17
FIGURE 12	NOP COMMAND .....	18
FIGURE 13	SLAVE ADDRESS CONSTRUCTION .....	22
FIGURE 14	PWM FORMAT.....	23
FIGURE 15	PACKAGE MARKING .....	23
FIGURE 16:	TYPICAL MAGNET AND MAGNETIC FLUX DISTRIBUTION.....	26
FIGURE 17:	DEFINED CHIP CENTER AND MAGNET DISPLACEMENT RADIUS .....	27
FIGURE 18:	VERTICAL PLACEMENT OF THE MAGNET.....	27

## List of Tables

TABLE 1:	PIN DESCRIPTION TSSOP14.....	5
TABLE 2	ABSOLUTE MAXIMUM RATINGS .....	6
TABLE 3:	OPERATING CONDITION.....	7
TABLE 4:	DC/AC CHARACTERISTICS .....	7
TABLE 5	SYSTEM SPECIFICATION.....	8
TABLE 6	GLOBAL TIMING CONDITIONS .....	8
TABLE 7	SPI TIMING CHARACTERISTICS .....	11
TABLE 8	SPI COMMAND PACKAGE .....	13
TABLE 9	SPI READ PACKAGE.....	14
TABLE 10	SPI WRITE DATA PACKAGE.....	14
TABLE 11	SPI REGISTER MAP .....	15

# AS5048A/AS5048B

Datasheet

Magnetic Rotary Encoder  
14-bit Angular Position Sensor

TABLE 12 CLEAR ERROR FLAG COMMAND .....	17
TABLE 13 NOP COMMAND.....	18
TABLE 14 I <sup>2</sup> C ELECTRICAL SPECIFICATION .....	19
TABLE 15 I <sup>2</sup> C TIMING .....	20
TABLE 16 REGISTER MAP I2C .....	21
TABLE 17 PWM PERIOD AND RESOLUTION .....	23
TABLE 18: ORDERING INFORMATION .....	28

ams AG  
Technical content still valid

# AS5048A/AS5048B

Datasheet

Magnetic Rotary Encoder  
14-bit Angular Position Sensor

## 1 Pin Configuration

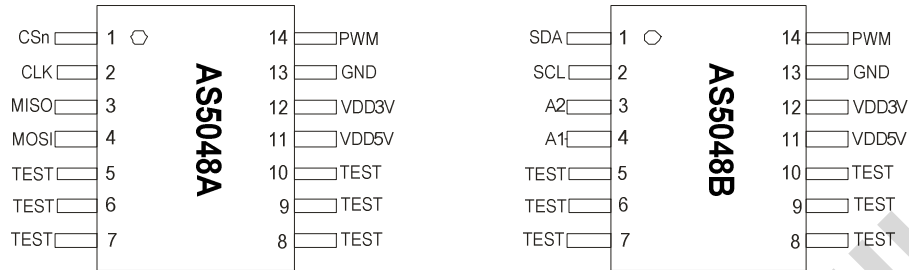

Figure 1: Pin configuration TSSOP14

### 1.1 Pin Description

Pin	AS5048A	Type	Description	AS5048B	Type	Description
1	CSn	DI_ST	SPI chip select - active low	SDA	DIO_OD	Data pin I2C interface
2	CLK	DI_ST	SPI clock input	SCL	DI_ST	I2C clock input
3	MISO	DIO_ST	SPI master in/slave out	A2	DI_ST	I2C address selection pin 3
4	MOSI	DI_ST	SPI master out/slave in	A1	DI_ST	I2C address selection pin 4
5	TEST	AIO	Test pin, see Note	Same as AS5048A		
6	TEST	AIO	Test pin, see Note			
7	TEST	AIO	Test pin, see Note			
8	TEST	AIO	Test pin, see Note			
9	TEST	AIO	Test pin, see Note			
10	TEST	AIO	Test pin, see Note			
11	VDD5V	S	Positive Supply Voltage, 3.0 to 5.5 V			
12	VDD3V	S	3.3V Regulator output; internally regulated from VDD. Connect to VDD for 3V supply voltage. 10µF capacitor to GND required in 5V operation mode			
13	GND	S	Negative Supply Voltage (GND)			
14	PWM	DO	Pulse Width Modulation output			

Table 1: Pin description TSSOP14

PIN Types:

S	...	supply pad
AIO	...	analog I/O
DI_ST	...	digital input with schmitt trigger
DO	...	digital output – push-pull
DIO_ST	...	digital I/O with schmitt trigger in the input path
DIO_OD	...	digital I/O with open drain output

Note: Pin 5, 6, 7, 8, 9, 10 should be grounded to GND.

# AS5048A/AS5048B

## Datasheet

Magnetic Rotary Encoder  
14-bit Angular Position Sensor

## 2 Electrical Characteristics

### 2.1 Absolute Maximum Ratings

Stresses beyond those listed under "Absolute Maximum Ratings" may cause permanent damage to the device. These are stress ratings only. Functional operation of the device at these or any other conditions beyond those indicated under "Operating Conditions" is not implied. Exposure to absolute maximum rating conditions for extended periods may affect device reliability.

Parameter	Symbol	Min	Max	Unit	Note
DC supply voltage at VDD pin	VDD5V	-0.3	7	V	
DC voltage at VDD3V pin	VDD3V	-0.3	5	V	
DC voltage at GND pin	GND	-0.3	0.3	V	
Input pin voltage	V <sub>in</sub>		VDD+0.3	V	
Input current (latchup immunity)	I <sub>scr</sub>	-100	100	mA	Norm: Jecdec 78
Electrostatic discharge	ESD		+/-2	kV	Norm: MIL 883 E method 3015
Total power dissipation (all supplies and outputs)	P <sub>t</sub>		150	mW	
Storage temperature	T <sub>strg</sub>	-55	150	°C	
Package body temperature	T <sub>body</sub>		260	°C	The reflow peak soldering temperature (body temperature) specified is in accordance with IPC/JEDEC J-STD-020 "Moisture Solid State Surface Mount Devices". The lead finish from Pb-free leaded packages is matte tin (100% Sn)
Humidity non-condensing	H	5	85	%	
Moisture Sensitive Level	MSL		3		Represents a maximum floor life time of 168h

Table 2 Absolute Maximum Ratings

# AS5048A/AS5048B

Datasheet

Magnetic Rotary Encoder  
14-bit Angular Position Sensor

## 2.2 Operating Conditions

All in this specification defined tolerances for external components need to be assured over the whole operation conditions range and also over lifetime.

Parameter	Symbol	Min	Max	Unit	Note
Positive supply voltage	VDD5V	4.5	5.5	V	5V Operation via LDO
	VDD3V	3	3.6	V	LDO output voltage
Positive core supply voltage	VDDCORE	3	3.6	V	
Negative supply voltage	GND	0	0	V	
Ambient temperature	T_amb	-40	150	°C	Only for 5V operation. T_amb_max for 3V is 125°C
Supply Current	I_sup		15	mA	

Table 3: Operating Condition

## 2.3 DC/AC Characteristics for digital inputs and outputs

Parameter	Symbol	Min	Typ	Max	Unit	Note
CMOS digital input with schmitt trigger: CSn, CLK, MOSI						
High level input voltage	V_IH	0.7 * VDD5V			V	
Low level input voltage	V_IL			0.3 * VDD5V	V	
Input leakage current	I_LEAK			1	µA	
CMOS output: PWM, MISO						
High level output voltage	V_OH	VDD5V-0.5			V	
Low level output voltage	V_OL			GND+0.4	V	
Capacitive load	C_L			50	pF	
Output current	I_OUT			4	mA	

Table 4: DC/AC characteristics



# AS5048A/AS5048B

Datasheet

Magnetic Rotary Encoder  
14-bit Angular Position Sensor

## 2.4 Electrical System Specifications

VDD5V = 5V, T<sub>Ambient</sub> = -40 to +150°C unless noted otherwise

Parameter	Symbol	Min	Typ	Max	Unit	Note
Magnetic input field	Bz	30	50	70	mT	
Output sampling rate	f <sub>sample</sub>	10.2	11.25	12.4	kHz	
Output Resolution	RES	14			Bit	
Sensor output noise	Noise			0.06	Deg	2.73LSB@14bit, rms value
System propagation delay	t <sub>prop</sub>	90.7	100	110.2	µs	
PWM frequency	f <sub>PWM</sub>	0.907	1	1.102	kHz	
Non-linearity optimum placement of magnet	INL <sub>OPT</sub>			±0.4	Deg	Assuming 8 mm diameter of magnet
Non-linearity @displacement of magnet	INL <sub>DIS</sub>			±0.7	Deg	Assuming 8 mm diameter of magnet and 500 µm displacement in x and y
Non-linearity @displacement of magnet and temperature -40 -150 degC	INL <sub>DIS+TEMP</sub>			±1.2	Deg	Assuming 8 mm diameter of magnet and 500 µm displacement in x and y
Startup Time	t <sub>startup</sub>			10	ms	

Table 5 System specification

## 2.5 Global Timing Conditions

Parameter	Symbol	Min	Typ	Max	Unit	Note
Internal Master Clock	F <sub>osc</sub>	4.05	4.5	4.95	MHz	±10%
	T <sub>osc</sub>	1/F <sub>osc</sub>			Hz	

Table 6 Global timing conditions

# AS5048A/AS5048B

Datasheet

Magnetic Rotary Encoder  
14-bit Angular Position Sensor

## 3 Functional Description

The AS5048 is a magnetic Hall sensor system manufactured in a CMOS process. A lateral Hall sensor array is used to measure the magnetic field components perpendicular to the surface of the chip. The AS5048 uses self-calibration methods to eliminate signal offset and sensitivity drifts.

The integrated Hall sensors are placed around the center of the device and deliver a voltage representation of the magnetic flux  $B_z$ .

Through Sigma-Delta Analog-to-Digital Converter (ADC) and Digital Signal-Processing (DSP) algorithms, the AS5048 provides accurate high-resolution absolute angular position information. This is accomplished by a Coordinate Rotation Digital Computer (CORDIC) calculates the angle and the magnitude of the Hall array signals.

The DSP is also used to provide digital information at the outputs that indicate movements of the magnet towards or away from the device's surface, in the z-axis.

A small diametrically magnetized (two-pole) standard magnet provides the angular position information. Depending on the system requirements different magnet diameters are possible. Additional flexibility is given by the wide range of the magnetic input range. The AS5048 can be combined with NeFeB, SmCo and alternative magnet materials e.g. hard ferrites. The AS5048 provides a 14-bit binary code representing the angular position of the magnet. The type of output is pre-programmed as SPI version A or I2C version B. Simultaneously a PWM output signal is available in 12 bit format.

A simple programming of the zero position is possible over the interface. No additional programmer is needed. The AS5048 uses one time programmable (OTP) fuses for permanent programming of the user settings. The verification is possible over a simple digital readout of the OTP content.

## 4 Operation

### 4.1 Supply Voltage Configuration

The AS5048 operates at  $5V \pm 10\%$ , using an internal Low-Dropout (LDO) voltage regulator. In addition a 3.3V operation is possible. The **VDD3V** output is intended for internal use only. **It must not be loaded with an external load.**

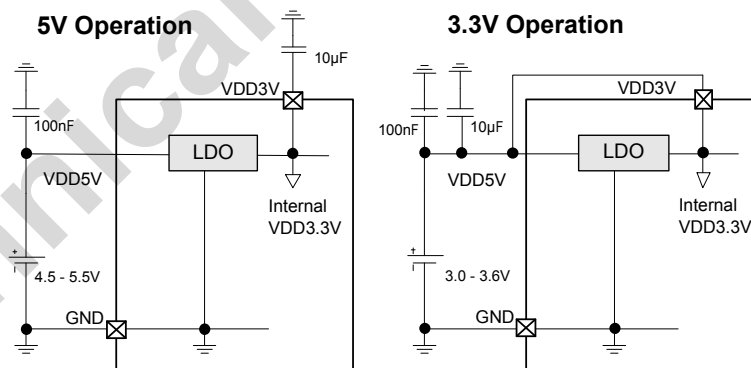

Figure 2: Connections for 5V and 3.3V supply voltages

**Note:** The pin **VDD3V** must always be buffered by a 10  $\mu F$  capacitor in 5V operation. It must not be left floating, as this may cause unstable internal supply voltages which may lead to larger output jitter of the measured angle.

In 3V operation the **VDD3V** must be shorted to **VDD5V**. The ambient temperature  $T_{amb}$  is limited to 125 degC in this mode.

# AS5048A/AS5048B

Magnetic Rotary Encoder  
14-bit Angular Position Sensor

## 4.2 SPI Interface

The 16 bit SPI Interface enables read / write access to the register blocks and is compatible to a standard micro controller interface. The SPI is active as soon as **CSn** is pulled low. The AS5048A then reads the digital value on the **MOSI**(master out slave in) input with every falling edge of **CLK** and writes on its **MISO** (master in slave out) output with the rising edge. After 16 clock cycles **CSn** has to be set back to a high status in order to reset some parts of the interface core.

### 4.2.1 SPI Interface Signals (4-Wire Mode, Wire\_mode = 1)

The AS5048A only supports slave operation mode. Therefore **CLK** for the communication as well as the **CSn** signal has to be provided by the test equipment. The following picture shows a basic interconnection diagram with one master and an AS5048A device and a principle schematic of the interface core.

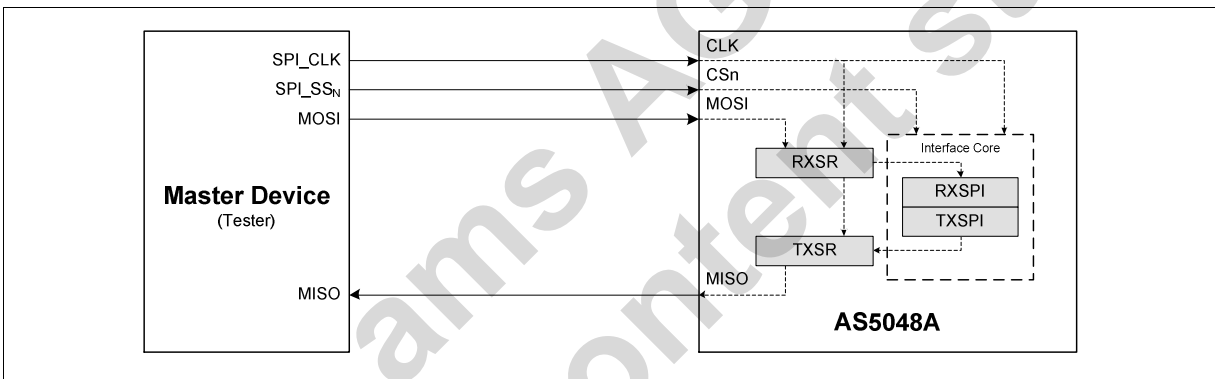

Figure 3 SPI Connection AS5048A with uC

Because the interface has to decode the sent command before it can react and provide data the response of the chip to a specific command applied at a time T can be accessed in the next transmission cycle ending at T + T<sub>COM</sub>. The data are sent and read with **MSB first**. Every time the chip is accessed it is sending and receiving data.

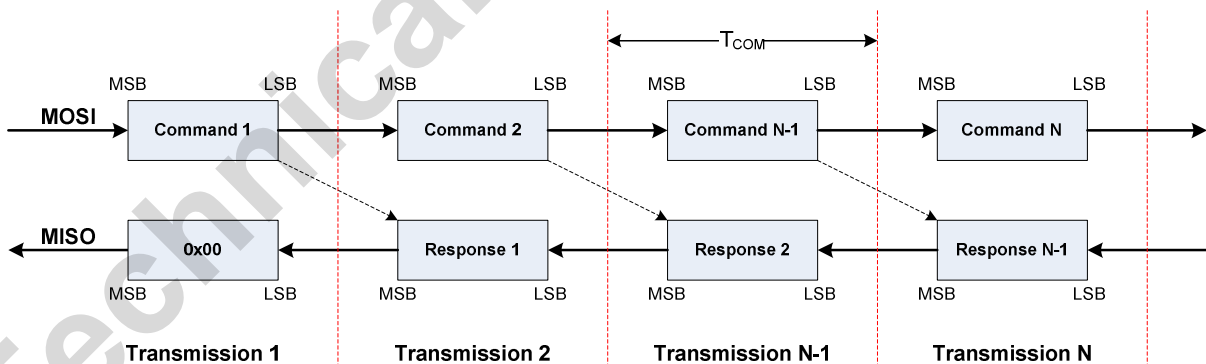

Figure 4 SPI Command/Response Data Flow

# AS5048A/AS5048B

Datasheet

Magnetic Rotary Encoder  
14-bit Angular Position Sensor

## 4.2.2 SPI Timing

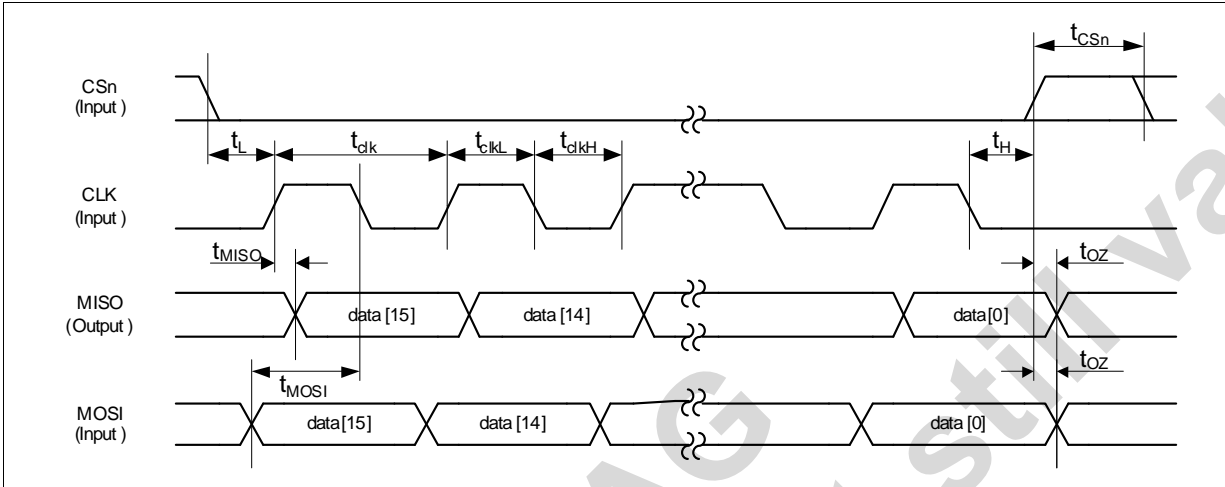

Figure 5 SPI Timing Diagram

Parameter	Description	Min	Max	Unit
$t_L$	Time between CSn falling edge and CLK rising edge	10 (2)		ns
$t_L$	Time between CSn falling edge and CLK rising edge	350 (1)		ns
$T_{CLK}$	Serial clock period	100		ns
$t_{CLKL}$	Low period of serial clock	50		ns
$t_{CLKH}$	High period of serial clock	50		ns
$t_H$	Time between last falling edge of CLK and rising edge of CSn	$t_{CLK} / 2$		ns
$T_{CSnH}$	High time of CSn between two transmissions	10 (2)		ns
$T_{CSnH}$	High time of CSn between two transmissions	350 (1)		ns
$t_{MOSI}$	Data input valid to clock edge	20		ns
$t_{MISO}$	CLK edge to data output valid		20	ns

Table 7 SPI Timing Characteristics

Notes:

- (1) Synchronization with the internal clock  $\rightarrow 2 * t_{CLK\_SYS} + 10 \text{ ns}$  (e.g. at 8 MHz  $\rightarrow 253 \text{ ns}$ )
- (2) No synchronization needed because the internal clock is inactive

# AS5048A/AS5048B

Datasheet

Magnetic Rotary Encoder  
14-bit Angular Position Sensor

## 4.2.3 SPI Connection to the Host UC

### Single Slave Mode

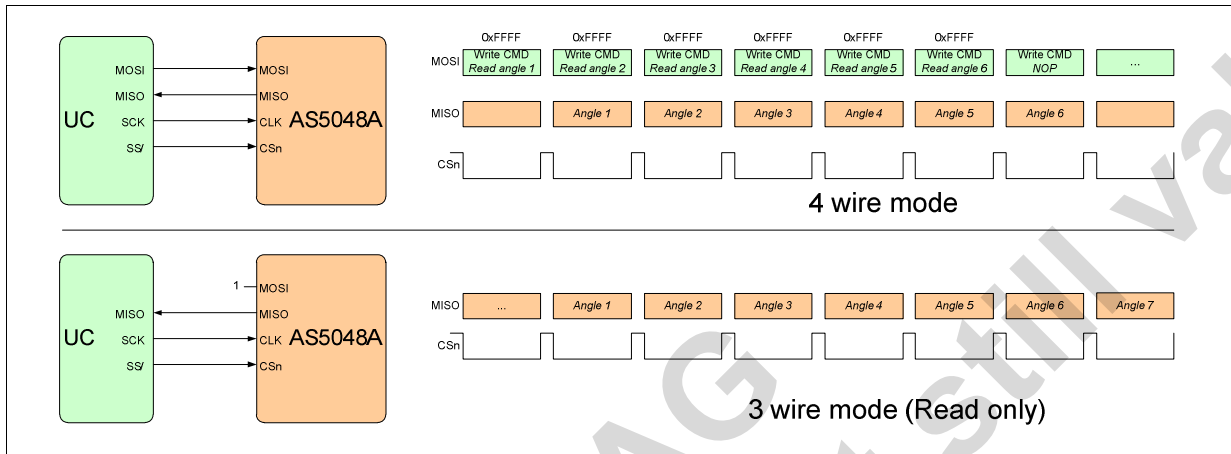

Figure 6 Single Slave Mode

### 3 Wire Mode (read only):

### Multiple Slave, n+3 Wire (Separate ChipSelect)

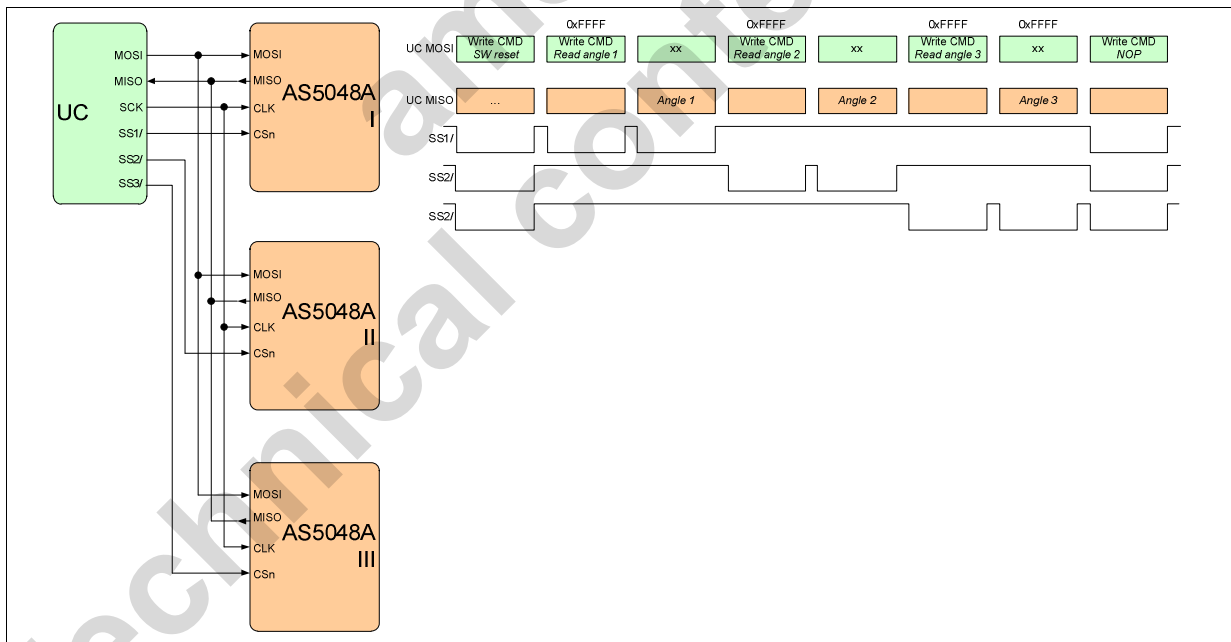

Figure 7 Multiple Slave, n+3 Wire (Separate ChipSelect)

# AS5048A/AS5048B

Datasheet

Magnetic Rotary Encoder  
14-bit Angular Position Sensor

## Daisy Chain, 4 Wire

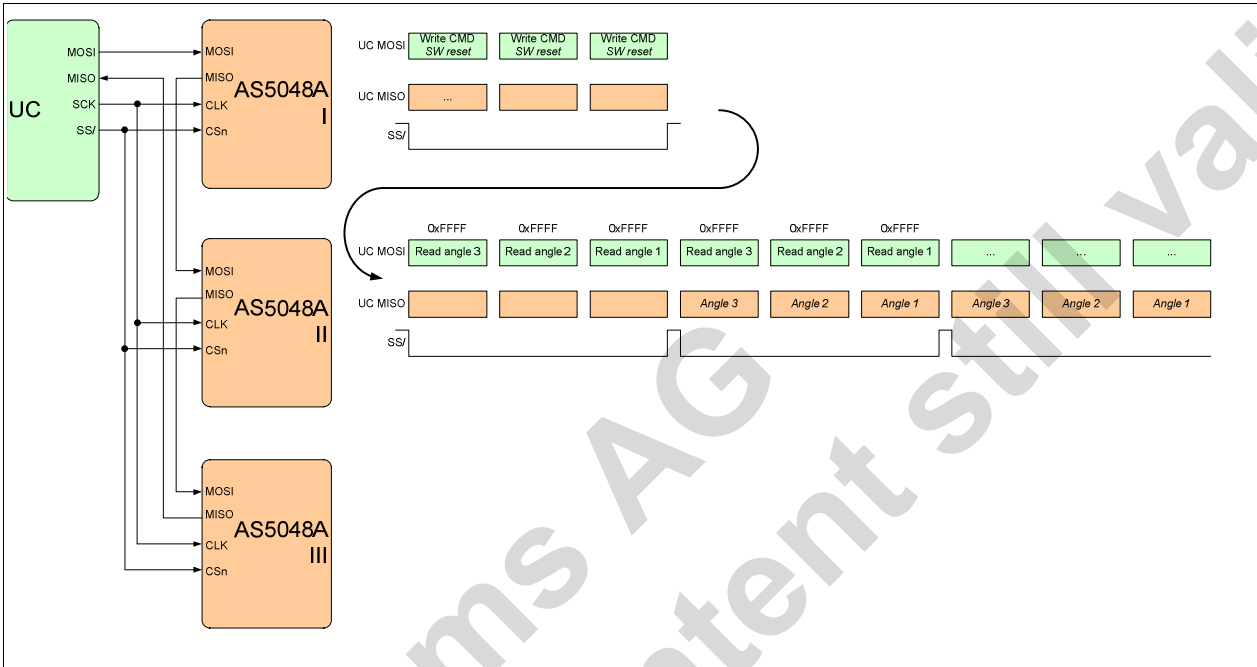

Figure 8 Daisy Chain, 4 Wire

### 4.2.4 SPI Communication Command Package

Every command sent to the AS5048A is represented with the following layout.

Command Package																
Bit	MSB	14	13	12	11	10	9	8	7	6	5	4	3	2	1	LSB
	PAR	RWn	Address<13:0>													
Bit Definition & Description																
PAR		Parity bit (EVEN)														
RWn		Indicates read(1) or write(0) command														
Address		14 bit address code														

Table 8 SPI Command Package

# AS5048A/AS5048B

Datasheet

Magnetic Rotary Encoder  
14-bit Angular Position Sensor

## 4.2.5 Read Package (Value Read from AS5048A)

The read frame always contains two alarm bits, the parity and error flags and the addressed data of the previous read command.

Read Package																
Bit	MSB	14	13	12	11	10	9	8	7	6	5	4	3	2	1	LSB
	PAR	EF	Data<13:0>													
Bit Definition & Description																
PAR		Parity bit (EVEN)														
EF		Error flag indicating a transmission error in a previous host transmission														
Data		14 bit addressed data														

Table 9 SPI read package

## 4.2.6 Write Data Package (Value Written to AS5048A)

The write frame is compatible to the read frame and contains two additional bits, parity flag and R flag.

If the previous command was a write command a second package has to be transmitted.

Data Package																
Bit	MSB	14	13	12	11	10	9	8	7	6	5	4	3	2	1	LSB
	PAR	R	Data <13:0>													
Bit Definition & Description																
PAR		Parity bit (EVEN)														
R		Has to be 0														
Data		14 bit data to write to former selected address														

Table 10 SPI write data package

# AS5048A/AS5048B

Datasheet

Magnetic Rotary Encoder  
14-bit Angular Position Sensor

## 4.2.7 Register Map SPI

	Address	Name	Access	Bit Nr.	Symbol	Default	Description		
	hex		Type						
Control and Error Registers	x0000	SPI NOP	R	13	NOP	0	No operation dummy information		
				0					
	x0001	Clear Error Flag	R	13	not used	n.a.	Error Register. All errors are cleared by access		
				3					
				2				Parity Error	0
				1				Command Invalid	
	0	Framing Error							
	x0003	Programming Control	R/W	13	not used	0	Programming control register. Programming must be enabled before burning the fuse(s). After programming is a verification mandatory. See programming procedure.		
				7					
				6				Verify	
				5				not used	
				4				not used	
3				Burn					
2				reserved					
1				reserved					
0	Programming Enable								
Programmable Customer settings	x0016	OTP Register Zero Position Hi	R/W + Program	13	not used	0	Zero Position value high byte		
				8					
				7				Zero Position <13>	0
				0				Zero Position <6>	0
	x0017	OTP Register Zero Position Low 6 LSBs	R/W + Program	13	not used	0	Zero Position remaining 6 lower LSB's		
				6					
				5				Zero Position <5>	0
				0				Zero Position <0>	0
Readout Registers	x3FFD	Diagnostics + Automatic Gain Control (AGC)	R	13	not used	n.a.	Diagnostics flags		
				12					
				11				Comp High	0
				10				Comp Low	0
				9				COF	0
				8				OCF	1
				7				AGC value<7>	1
				0				AGC value<0>	0
	0	AGC value<0>	0						
	x3FFE	Magnitude	R	13	Magnitude<13>	0	Automatic Gain Control value. 0 decimal represents high magnetic field 255 decimal represents low magnetic field		
				0				Magnitude<0>	0
	x3FFF	Angle	R	13	Angle <13>	0	Angle information after ATAN calculation and zero position adder		
0				Angle<0>				0	

Table 11 SPI register map



# AS5048A/AS5048B

Datasheet

Magnetic Rotary Encoder  
14-bit Angular Position Sensor

## 4.2.8 SPI Interface Commands

### READ Command

For a single *READ* command two transmission sequences are necessary. The first package written to the AS5048 contains the *READ* command (**MSB-1 high**) and the address the chip has to access, the second package transmitted to the AS5048 device can be *any command* the chip has to process next. The content of the desired register is available in the *MISO* register of the *master device* at the end of the second transmission cycle.

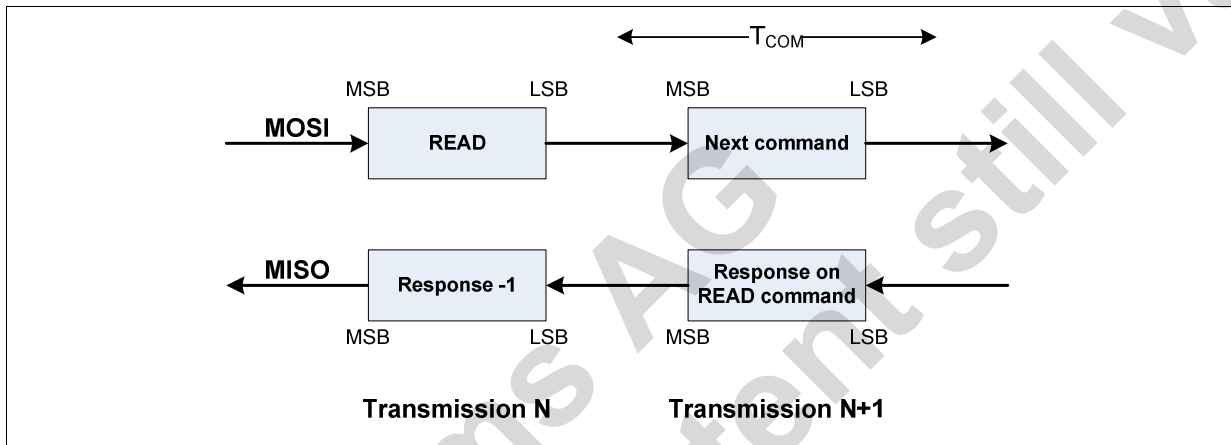

Figure 9 READ Command

### WRITE Command

A single *WRITE* command takes two transmission cycles. With a NOP command after the *WRITE* command you can verify the sent data with three transmission cycles because the data will be send back during the following command.

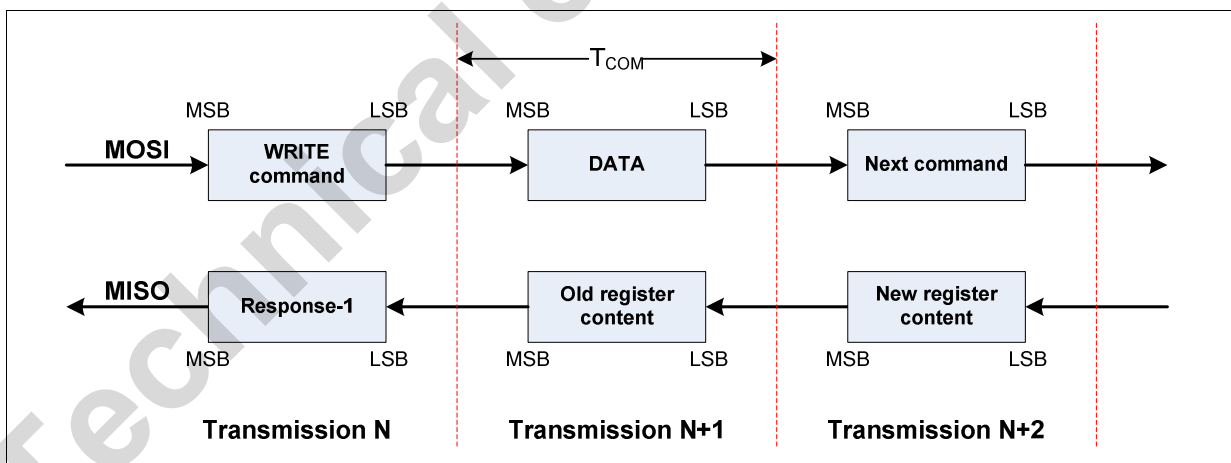

Figure 10 WRITE Command

# AS5048A/AS5048B

Datasheet

Magnetic Rotary Encoder  
14-bit Angular Position Sensor

## CLEAR ERROR FLAG Command

The *CLEAR ERROR FLAG* command is implemented as *READ* command. This command clears the *ERROR FLAG* which is contained in every *READ* frame. Before the *ERROR FLAG* is cleared the error register content comes back with the information which error type was occurred. On the next new *READ* register the *ERROR FLAG* is cleared

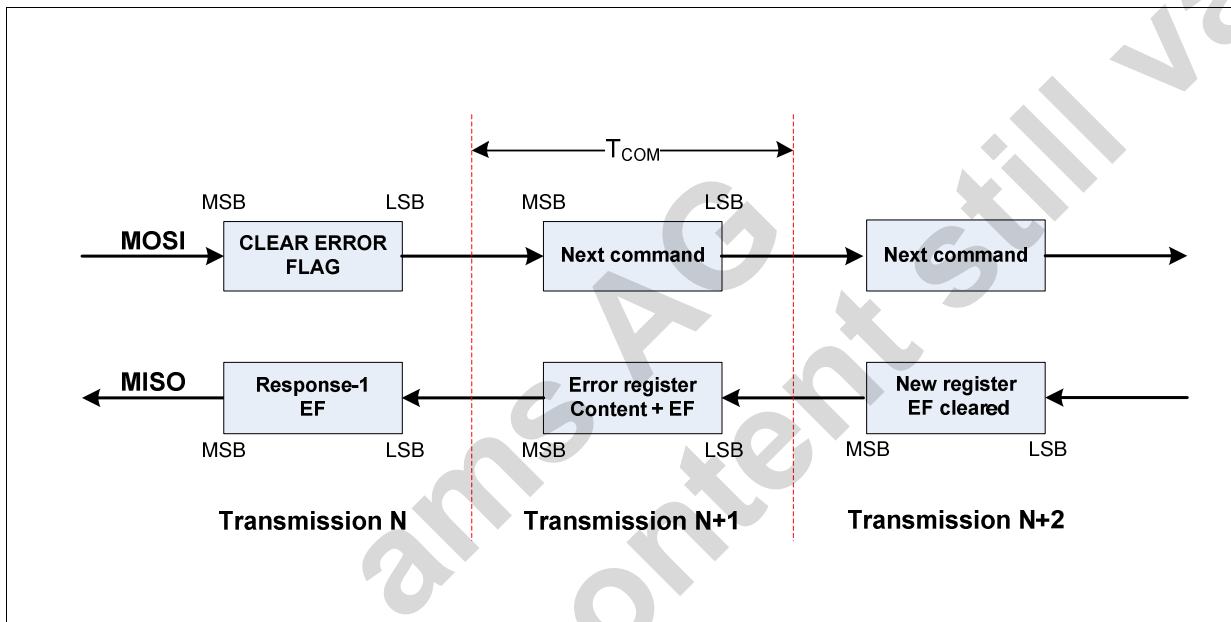

Figure 11 CLEAR ERROR FLAG Command

The package necessary to perform a *CLEAR ERROR FLAG* is built up as follows.

CLEAR ERROR FLAG Command																
Bit	MSB	14	13	12	11	10	9	8	7	6	5	4	3	2	1	LSB
	PAR	1	0	0	0	0	0	0	0	0	0	0	0	0	0	1

Table 12 Clear Error Flag Command

Possible conditions which force the *ERROR FLAG* to be set:

- wrong parity
- wrong number of clocks (no full transmission cycle or too many clocks)

Note: If the error flag is set to high because of a communication problem the flag remains set until it will be cleared by the *CLEAR ERROR FLAG* command.

# AS5048A/AS5048B

Datasheet

Magnetic Rotary Encoder  
14-bit Angular Position Sensor

## NOP Command

The *NOP* command represents a dummy write to the AS5048.

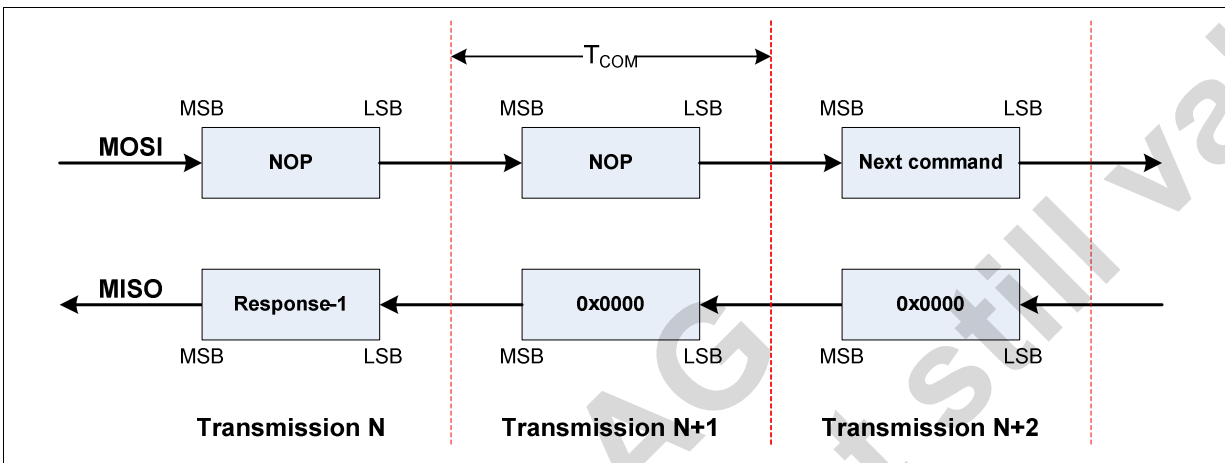

Figure 12 NOP Command

The *NOP* command frame looks like follows.

NOP Command																
Bit	MSB	14	13	12	11	10	9	8	7	6	5	4	3	2	1	LSB
	0	0	0	0	0	0	0	0	0	0	0	0	0	0	0	0

Table 13 NOP Command

The chip's response on this command is 0x0000 – if no error happens.

# AS5048A/AS5048B

Datasheet

Magnetic Rotary Encoder  
14-bit Angular Position Sensor

## 4.3 I<sup>2</sup>C interface

The AS5048B supports 2-wire high-speed I<sup>2</sup>C protocol in device mode. The host MCU (master) has to initiate the data transfers. The 7-bit device address of the slave depends on the state of the OTP I<sup>2</sup>C register 21 (0x15) bit 0...4 + 2 I<sup>2</sup>C address selection pin 3 and 4.

Supported modes:

- Random/Sequential Read
- Byte/Page Write
- Standard : 0 to 100kHz clock frequency (slave mode)
- Fast Mode : 0 to 400kHz clock frequency (slave mode)
- High Speed: 0 to 3.4MHz clock frequency (slave mode)

The SDA signal is bidirectional and is used to read and write the serial data. The SCL signal is the clock generated by the host MCU, to synchronize the SDA data in read and write mode. The maximum I<sup>2</sup>C clock frequency is 3.4MHz, data are triggered on the rising edge of SCL.

### 4.3.1 I<sup>2</sup>C Electrical Specification

Symbol	Parameter	Condition	FS-mode+		HS-mode C <sub>B</sub> =100pF		HS-mode C <sub>B</sub> =400pF		Unit
			Min	Max	Min	Max	Min	Max	
V <sub>IL</sub>	LOW-Level Input Voltage		-0.5	0.3V <sub>DD</sub>	-0.5	0.3V <sub>DD</sub>	-0.5	0.3V <sub>DD</sub>	V
V <sub>IH</sub>	HIGH-Level Input Voltage		0.7V <sub>DD</sub>	V <sub>DD</sub> + 0.5 (1)	0.7V <sub>DD</sub>	V <sub>DD</sub> + 0.5 (1)	0.7V <sub>DD</sub>	V <sub>DD</sub> + 0.5 (1)	V
V <sub>hys</sub>	Hysteresis of Schmitt Trigger Inputs	V <sub>DD</sub> < 2V	0.1V <sub>DD</sub>	--	0.1V <sub>DD</sub>	--	0.1V <sub>DD</sub>	--	V
V <sub>OL</sub>	LOW-Level Output Voltage (open-drain or open-collector) at 3mA Sink Current	V <sub>DD</sub> < 2V	--	0.2V <sub>DD</sub>	--	0.2V <sub>DD</sub>	--	0.2V <sub>DD</sub>	V
I <sub>OL</sub>	LOW-Level Output Current	V <sub>OL</sub> = 0.4V	20		--	--	--	--	mA
I <sub>CS</sub>	Pull-up current of SCLH current source		--	--	3	12	3	12	mA
t <sub>SP</sub>	Pulse Width of Spikes that must be suppressed by the Input Filter		--	50 (2)	--	10	--	10	ns
I <sub>i</sub>	Input Current at each I/O Pin	Input Voltage between	-10	+10 (3)	--	10	--	10	μA
C <sub>B</sub>	Total Capacitive Load for each Bus Line		--	550	--	100	--	400	pF
C <sub>I/O</sub>	I/O Capacitance (SDA, SCL)		--	10	--	10	--	10	pF

Table 14 I<sup>2</sup>C Electrical Specification

- (1) Maximum V<sub>IH</sub> = V<sub>DDmax</sub> + 0.5V or 5.5V
- (2) Input filters on the SDA and SCL inputs suppress noise spikes of less than 50 ns.
- (3) I/O pins of Fast-mode and Fast-mode Plus devices must not obstruct the SDA and SCL lines if V<sub>DD</sub> is switched off.

# AS5048A/AS5048B

## Datasheet

Magnetic Rotary Encoder  
14-bit Angular Position Sensor

### 4.3.2 I<sup>2</sup>C Timing

			FS-mode+		HS-mode C <sub>B</sub> =100pF		HS-mode C <sub>B</sub> =400pF (5)		
Symbol	Parameter	Condition	Min	Max	Min	Max	Min	Max	Unit
f <sub>SCLK</sub>	SCL clock Frequency		--	1000	--	3400	--	1700	kHz
t <sub>BUF</sub>	Bus Free Time; time between STOP and START Condition		500	--	500	--	500	--	ns
t <sub>HD,STA</sub>	Hold Time; (Repeated) START Condition (1)		260	--	160	--	160	--	ns
t <sub>LOW</sub>	LOW Period of SCL Clock		500	--	160	--	320	--	ns
t <sub>HIGH</sub>	HIGH Period of SCL Clock		260	--	60	--	120	--	ns
t <sub>SU,STA</sub>	Setup Time for a Repeated START condition		260	--	160	--	160	--	ns
t <sub>HD,DAT</sub>	Data Hold Time (2)		0	450	0	70	0	150	ns
t <sub>SU,DAT</sub>	Data Setup Time (3)		50	--	10	--	10	--	ns
t <sub>r</sub>	Rise Time of SDA and SCL Signals		20+0.1 C <sub>b</sub>	120	--	--	--	--	ns
t <sub>f</sub>	Fall time of SDA and SCL signals		20+0.1 C <sub>b</sub>	120 (4)	--	--	--	--	ns
t <sub>rCL</sub>	Rise time of SCLH signal	Ext. pull-up source of 3mA	--	--	10	40	20	80	ns
t <sub>rCL1</sub>	Rise time of SCLH signal after repeated START condition and after an acknowledge bit	Ext. pull-up source of 3mA	--	--	10	80	20	160	ns
t <sub>fCL</sub>	Output rise time of SCLH signal	Ext. pull-up source of 3mA	--	--	10	40	20	80	ns
t <sub>rDA</sub>	Output rise time of SDAH signal		--	--	10	80	20	160	ns
t <sub>fDA</sub>	Output rise time of SDAH signal		--	--	10	80	20	160	ns
t <sub>SU,STO</sub>	Setup Time for STOP Condition		260	--	160	--	160	--	ns
V <sub>nL</sub>	Noise margin at LOW level		0.1V <sub>DDP</sub>	--	0.1V <sub>DDP</sub>	--	0.1V <sub>DDP</sub>	--	V
V <sub>nH</sub>	Noise margin at HIGH level		0.2V <sub>DDP</sub>	--	0.2V <sub>DDP</sub>	--	0.2V <sub>DDP</sub>	--	V

Table 15 I<sup>2</sup>C Timing

- (1) after this time the first clock is generated
- (2) A device must internally provide a minimum hold time (120ns / max 250ns for Fast-mode Plus, 80ns / max 150ns for High-speed mode) for the SDA signal (referred to the V<sub>IHmin</sub> of the SCL) to bridge the undefined region of the falling edge of SCL.
- (3) A fast-mode device can be used in standard-mode system, but the requirement t<sub>SU,DAT</sub> = 250ns must then be met. This is automatically the case if the device does not stretch the LOW period of the SCL signal. If such a device does stretch the LOW period of the SCL signal, it must output the next data bit to the SDA line t<sub>Rmax</sub> + t<sub>SU,DAT</sub> = 1000 + 250 = 1250ns before the SCL line is released.
- (4) In Fast-mode Plus, fall time is specified the same for both output stage and bus timing. If series resistors are used this has to be considered for bus timing
- (5) For capacitive bus loads between 100pF and 400pF, the timing parameters must be linearly interpolated

# AS5048A/AS5048B

Datasheet

Magnetic Rotary Encoder  
14-bit Angular Position Sensor

### 4.3.3 Register Table

The following registers / functions are accessible over the serial I<sup>2</sup>C interface.

	Address		Access		Symbol	Default	Description
	dec	Name	Type	Bit Nr.			
Control OTP	3	Programming Control	R/W	7	not used	0	Programming control register. Programming must be enabled before burning the fuse(s). After programming is an verification mandatory. See programming procedure.
				6	Verify		
				5	not used		
				4	not used		
				3	Burn		
				2	reserved		
				1	reserved		
				0	Programming Enable		
Programmable Customer settings	21	I <sup>2</sup> C slave address	R/W + Program	7	not used	n.a.	I <sup>2</sup> C slave address slave address consist of 5 programmable bits (MSBs) and the hardware setting of Pins A1 and A2 I <sup>2</sup> C address <4> is by default not programmed and due to the inversion defined as '1'
				5	not used	n.a.	
				4	I <sup>2</sup> C address<4>	internally inverted	
				:	:	:	
				0	I <sup>2</sup> C address<0>	0	
	22	OTP Register Zero Position Hi	R/W + Program	7	Zero Position <13>	0	Zero Position value high byte
				:	:	:	
				0	Zero Position <6>	0	
				:	:	:	
				0	Zero Position <0>	0	
23	OTP Register Zero Position Low 6 LSBs	R/W + Program	7	not used	n.a.	Zero Position remaining 6 lower LSB's	
			6	not used	n.a.		
			5	Zero Position <5>	0		
			:	:	:		
			0	Zero Position <0>	0		
			0	Zero Position <0>	0		
Readout Registers	250	Automatic Gain Control	R	7	AGC value<7>	1	Automatic Gain Control value. 0 decimal represents high magnetic field 255 decimal represents low magnetic field
				:	:	:	
				0	AGC value<0>	0	
	251	Diagnostics	R	7	not used	n.a.	Diagnostic flags
				4	not used	n.a.	
				3	Comp High	0	
				2	Comp Low	0	
				1	COF	0	
				0	OCF	1	
	252	Magnitude	R	7	Magnitude<13>	0	Magnitude information afer ATAN calculation
				:	:	:	
				0	Magnitude<6>	0	
				0	Magnitude<0>	0	
	253	Magnitude	R	7	not used	n.a.	Magnitude information afer ATAN calculation
				6	not used	n.a.	
				5	Magnitude<5>	0	
				:	:	:	
	254	Angle	R	7	Angle<13>	0	Angle Value afer ATAN calculation and zero position adder
				:	:	:	
				0	Angle<6>	0	
0				Angle<0>	0		
255	Angle	R	7	not used	n.a.	Angle Value afer ATAN calculation and zero position adder	
			6	not used	n.a.		
			5	Angle<5>	0		
			:	:	:		
255	Angle	R	0	Angle<0>	0	Angle Value afer ATAN calculation and zero position adder	
			0	Angle<0>	0		
			0	Angle<0>	0		
			0	Angle<0>	0		

Table 16 Register Map I<sup>2</sup>C

# AS5048A/AS5048B

Datasheet

Magnetic Rotary Encoder  
14-bit Angular Position Sensor

### 4.3.4 I<sup>2</sup>C Slave address

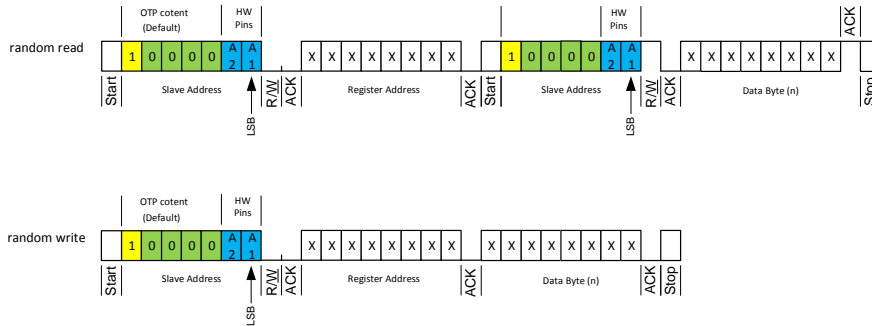

Figure 13 Slave address construction

The slave address consists of the hardware setting on pins A1, A2 and upper MSBs programmable by the user. The MSB of the slave address (yellow) is internally inverted. This means that by default the resulting data is '1'. A read of the I<sup>2</sup>C slave address register 21 will return a '0' at the MSB.

### 4.4 PWM interface

The AS5048 provides a pulse width modulated output (PWM), whose duty cycle is proportional to the measured angle. The PWM frequency is internally trimmed to an accuracy of  $\pm 10\%$  over full temperature range. This tolerance can be cancelled by measuring the complete duty cycle.

The PWM signal consists of different sections:

- Init:  
12 clocks -> PWM = 'high'
- Error\_n:  
4 clocks -> PWM = 'not(system\_error)'
- Data:  
4095 clocks -> PWM = 'angle\_zero' / 'low' (in case of error)
- Exit:  
8 clocks -> PWM = 'low'

In case of an error the data section is set to zero.

# AS5048A/AS5048B

Datasheet

Magnetic Rotary Encoder  
14-bit Angular Position Sensor

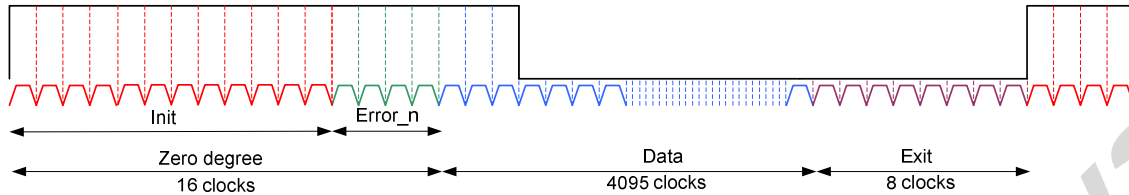

Figure 14 PWM Format

Parameter	Symbol	Value	Unit
PWM – Period	T_PWM	4119	T_PWM_BIT
PWM – Bit Time	T_PWM_BIT	1	T_OSC
PWM Resolution	N_PWM	4096	bit

Table 17 PWM Period and resolution

## 5 Package Drawings and Markings

Package type: TSSOP14

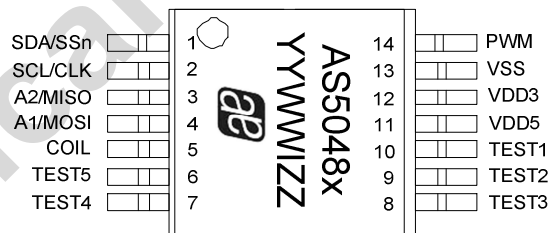

Figure 15 Package Marking

### 5.1.1 Assembly Lot Code

The assembly lot code for standard "YYWWIZZ" is composed as follows:

- X - Interface type: A=SPI / B=I<sup>2</sup>C
- YY - Year
- WW - Week
- I - Plant identification letter
- ZZ - Letters for free traceability



# AS5048A/AS5048B

Datasheet

Magnetic Rotary Encoder  
14-bit Angular Position Sensor

14-Lead Thin Shrink Small Outline Package TSSOP-14

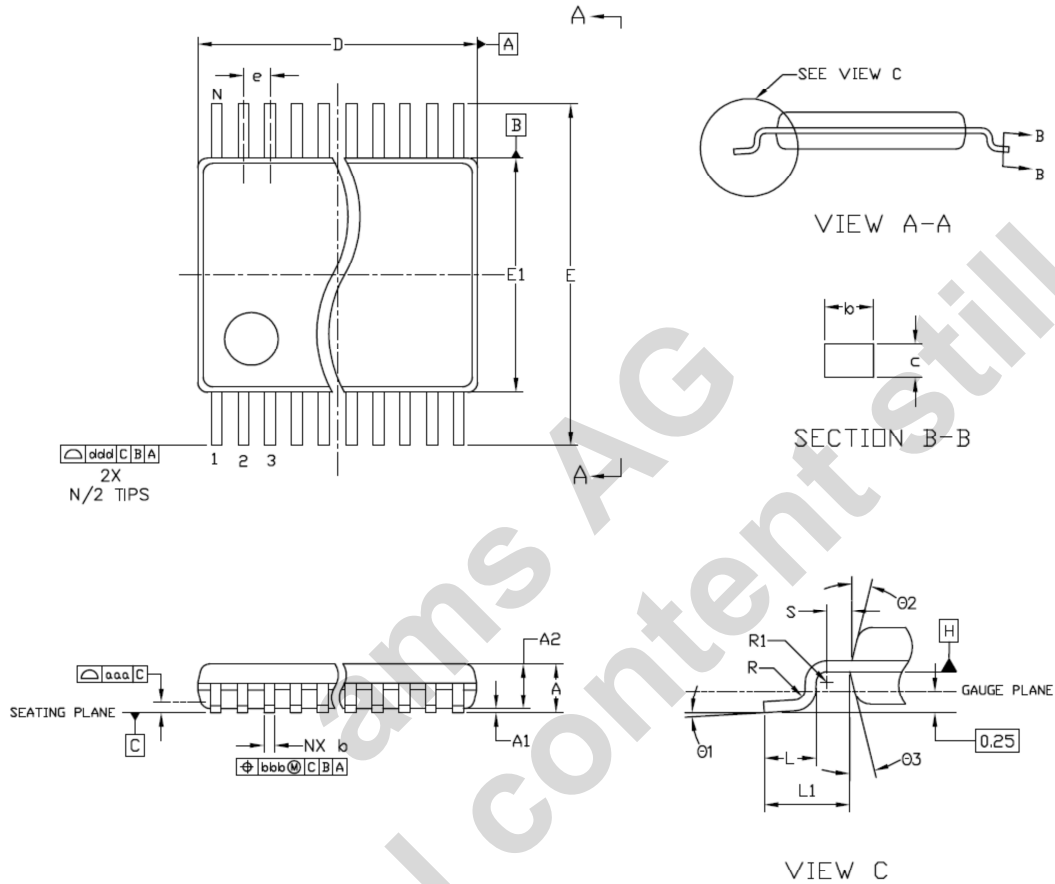

REF.	MIN	NOM	MAX
A	—	—	1.20
A1	0.05	—	0.15
A2	0.80	1.00	1.05
b	0.19	—	0.30
c	0.09	—	0.20
D	4.90	5.00	5.10
E	—	6.40 BSC	—
E1	4.30	4.40	4.50
e	—	0.65 BSC	—
L	0.45	0.60	0.75
L1	—	1.00 REF	—
R	0.09	—	—
R1	0.09	—	—
S	0.20	—	—
theta1	0°	—	8°
theta2	—	12 REF	—
theta3	—	12 REF	—
ddd	—	0.10	—
bbb	—	0.10	—
ccc	—	0.05	—
ddd	—	0.20	—
N	—	14	—

NOTE:

1. DIMENSIONS & TOLERANCEING CONFIRM TO ASME Y14.5M-1994.
2. ALL DIMENSIONS ARE IN MILLIMETERS. ANGELS ARE IN DEGREES.



# AS5048A/AS5048B

Datasheet

Magnetic Rotary Encoder  
14-bit Angular Position Sensor

## 6 Application Information

### 6.1 Programming of the AS5048

#### 6.1.1 Programming of the zero position

The absolute angle position can be permanent programmed over the interface. This could be useful for random placement of the magnet on the rotation axis. A readout at the mechanical zero position can be performed and written back into the IC. With permanent programming the position is non-reversible stored in the IC. This programming can be performed only once.

To simplify the calculation of the zero position it is only needed to write the value in the IC which was read out before from the angle register.

#### 6.1.2 Programming sequence with verification

To program the zero position is needed to perform following sequence:

1. Read angle information
2. Set the Programming Enable bit in the OTP control register
3. Write previous read angle position into OTP zero position register
4. Read back for verification the zero position register data
5. Set the Burn bit to start the automatic programming procedure
6. Read angle information (equals to 0)
7. Set the Verify bit to load the OTP data again into the internal registers with modified threshold comparator levels
8. Read angle information (equals to 0)

The programming can either be performed in 5V operation using the internal LDO, or in 3V operation but using a minimum supply voltage of 3.3V. In case of 3V operation, also a 10uF capacitor is required on the VDD3 pin.

### 6.2 Diagnostic functions of the AS5048

The AS5048 provides diagnostics functions of the IC and also diagnostic functions of the magnetic input field

Following diagnostic flags are available:

See Table 11 register address x3FFD (AS5048A) or Table 16 register address 251 dec (AS5048B)

**OCF (Offset Compensation Finished)**, logic high indicates the finished Offset Compensation Algorithm. After power up the flag remains always to logic high.

**COF (Cordic Overflow)**, logic high indicates an out of range error in the CORDIC part. When this bit is set, the angle and magnitude data is invalid. The absolute output maintains the last valid angular value.

**COMP low**, indicates a weak magnetic field. It is recommended to monitor in addition the magnitude value.

**COMP high**, indicated a high magnetic field. It is recommended to monitor the magnitude value.

# AS5048A/AS5048B

Datasheet

Magnetic Rotary Encoder  
14-bit Angular Position Sensor

## 6.3 Choosing the Proper Magnet

The AS5048 works with a variety of different magnets in size and shape. A typical magnet could be 6-8 mm in diameter and  $\geq 2.5\text{mm}$  in height. The magnetic field strength perpendicular to the die surface has to be in the range of  $\pm 30\text{mT} \dots \pm 70\text{mT}$  (peak).

The magnet's field strength should be verified using a gauss-meter. The magnetic flux  $B_z$  at a given distance, along a concentric circle with a radius of 1.1mm ( $R_1$ ), should be in the range of  $\pm 30\text{mT} \dots \pm 70\text{mT}$ .

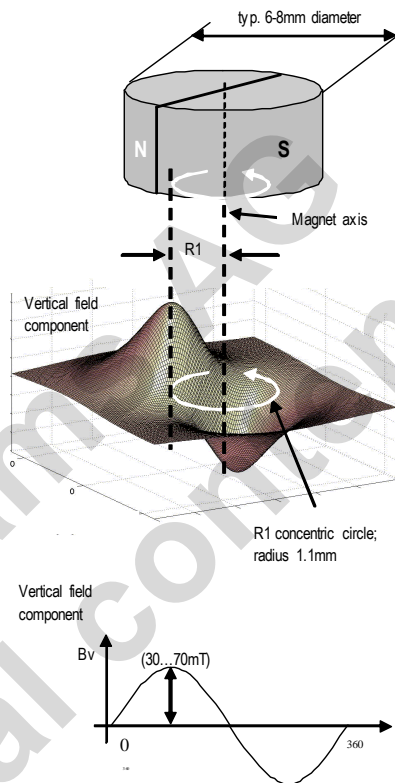

Figure 16: Typical magnet and magnetic flux distribution

# AS5048A/AS5048B

Datasheet

Magnetic Rotary Encoder  
14-bit Angular Position Sensor

## 6.4 Physical Placement of the Magnet

The best linearity can be achieved by placing the center of the magnet exactly over the defined center of the chip as shown in the drawing below:

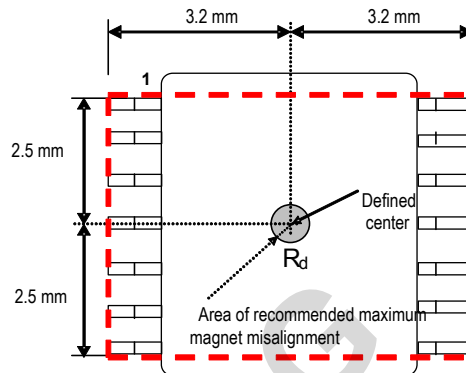

Figure 17: Defined chip center and magnet displacement radius

## 6.5 Magnet Placement

The magnet's center axis should be aligned within a displacement radius  $R_d$  of 0.25 mm (larger magnets allow more displacement e.g. 0.5 mm) from the defined center of the IC.

The magnet may be placed below or above the device. The distance should be chosen such that the magnetic field on the die surface is within the specified limits. The typical distance "z" between the magnet and the package surface is 0.5mm to 2.5mm, provided the use of the recommended magnet material and dimensions (6mm x 3mm). Larger distances are possible, as long as the required magnetic field strength stays within the defined limits.

However, a magnetic field outside the specified range may still produce usable results, but the out-of-range condition will be indicated by indication flags.

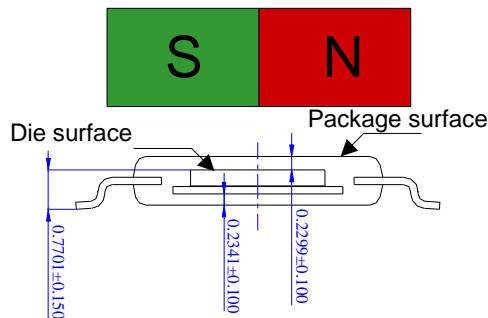

Figure 18: Vertical placement of the magnet

# AS5048A/AS5048B

Datasheet

Magnetic Rotary Encoder  
14-bit Angular Position Sensor

## 7 Ordering Information

Model	Description	Delivery Form	Package
AS5048A-HTSP	14 -Bit Programmable Magnetic Rotary Encoder with SPI-Interface	Tape&Reel	TSSOP 14
AS5048B-HTSP	14 -Bit Programmable Magnetic Rotary Encoder with I2C-Interface	Tape&Reel	TSSOP 14

Table 18: Ordering Information

## 8 Revision History

Revision	Date	Owner	Description
1.0	10-April-2012	mub	Initial revision
1.1	16-April-2012	mub	Minor correction text
1.2	09-May-2012	mub	Default pin configuration added. Minor text corrections
1.3	20-June-2012	mub	I2C Slave address explanation. Minor corrections.

[www.austriamicrosystems.com](http://www.austriamicrosystems.com)

# AS5048A/AS5048B

Datasheet

Magnetic Rotary Encoder  
14-bit Angular Position Sensor

## 9 Copyrights

Copyright © 1997-2012, austriamicrosystems AG, Schloss Premstaetten, 8141 Unterpremstaetten, Austria-Europe.

Trademarks Registered ®. All rights reserved. The material herein may not be reproduced, adapted, merged, translated, stored, or used without the prior written consent of the copyright owner.

All products and companies mentioned are trademarks or registered trademarks of their respective companies.

This product is protected by U.S. Patent No. 7,095,228.

## 10 Disclaimer

Devices sold by austriamicrosystems AG are covered by the warranty and patent indemnification provisions appearing in its Term of Sale. austriamicrosystems AG makes no warranty, express, statutory, implied, or by description regarding the information set forth herein or regarding the freedom of the described devices from patent infringement. austriamicrosystems AG reserves the right to change specifications and prices at any time and without notice. Therefore, prior to designing this product into a system, it is necessary to check with austriamicrosystems AG for current information. This product is intended for use in normal commercial applications. Applications requiring extended temperature range, unusual environmental requirements, or high reliability applications, such as military, medical life-support or lifesustaining equipment are specifically not recommended without additional processing by austriamicrosystems AG for each application.

The information furnished here by austriamicrosystems AG is believed to be correct and accurate. However, austriamicrosystems AG shall not be liable to recipient or any third party for any damages, including but not limited to personal injury, property damage, loss of profits, loss of use, interruption of business or indirect, special, incidental or consequential damages, of any kind, in connection with or arising out of the furnishing, performance or use of the technical data herein. No obligation or liability to recipient or any third party shall arise or flow out of austriamicrosystems AG rendering of technical or other services.