

# DATA SHEET

For a complete data sheet, please also download:

- The IC06 74HC/HCT/HCU/HCMOS Logic Family Specifications
- The IC06 74HC/HCT/HCU/HCMOS Logic Package Information
- The IC06 74HC/HCT/HCU/HCMOS Logic Package Outlines

## **74HC/HCT4060**

**14-stage binary ripple counter with oscillator**

Product specification  
File under Integrated Circuits, IC06

December 1990

## 14-stage binary ripple counter with oscillator

## 74HC/HCT4060

## FEATURES

- All active components on chip
- RC or crystal oscillator configuration
- Output capability: standard (except for  $R_{TC}$  and  $C_{TC}$ )
- $I_{CC}$  category: MSI

## GENERAL DESCRIPTION

The 74HC/HCT4060 are high-speed Si-gate CMOS devices and are pin compatible with "4060" of the "4000B" series. They are specified in compliance with JEDEC standard no. 7A.

The 74HC/HCT4060 are 14-stage ripple-carry counter/dividers and oscillators with three oscillator

terminals ( $R_S$ ,  $R_{TC}$  and  $C_{TC}$ ), ten buffered outputs ( $Q_3$  to  $Q_9$  and  $Q_{11}$  to  $Q_{13}$ ) and an overriding asynchronous master reset (MR).

The oscillator configuration allows design of either RC or crystal oscillator circuits. The oscillator may be replaced by an external clock signal at input  $R_S$ . In this case keep the other oscillator pins ( $R_{TC}$  and  $C_{TC}$ ) floating.

The counter advances on the negative-going transition of  $R_S$ . A HIGH level on MR resets the counter ( $Q_3$  to  $Q_9$  and  $Q_{11}$  to  $Q_{13}$  = LOW), independent of other input conditions.

In the HCT version, the MR input is TTL compatible, but the  $R_S$  input has CMOS input switching levels and can be driven by a TTL output by using a pull-up resistor to  $V_{CC}$ .

## QUICK REFERENCE DATA

GND = 0 V;  $T_{amb}$  = 25 °C;  $t_r$  =  $t_f$  = 6 ns

SYMBOL	PARAMETER	CONDITIONS	TYPICAL		UNIT
			HC	HCT	
$t_{PHL}/t_{PLH}$	propagation delay RS to $Q_3$	$C_L = 15$ pF; $V_{CC} = 5$ V	31	31	ns
	$Q_n$ to $Q_{n+1}$		6	6	ns
$t_{PHL}$	MR to $Q_n$		17	18	ns
$f_{max}$	maximum clock frequency		87	88	MHz
$C_I$	input capacitance		3.5	3.5	pF
$C_{PD}$	power dissipation capacitance per package	notes 1, 2 and 3	40	40	pF

## Notes

1.  $C_{PD}$  is used to determine the dynamic power dissipation ( $P_D$  in  $\mu$ W):

$$P_D = C_{PD} \times V_{CC}^2 \times f_i + \sum (C_L \times V_{CC}^2 \times f_o) \text{ where:}$$

$f_i$  = input frequency in MHz

$f_o$  = output frequency in MHz

$\sum (C_L \times V_{CC}^2 \times f_o)$  = sum of outputs

$C_L$  = output load capacitance in pF

$V_{CC}$  = supply voltage in V

2. For HC the condition is  $V_I = \text{GND to } V_{CC}$   
For HCT the condition is  $V_I = \text{GND to } V_{CC} - 1.5$  V
3. For formula on dynamic power dissipation see next pages.

## ORDERING INFORMATION

See "74HC/HCT/HCU/HCMOS Logic Package Information".

14-stage binary ripple counter with oscillator

74HC/HCT4060

PIN DESCRIPTION

PIN NO.	SYMBOL	NAME AND FUNCTION
1, 2, 3	Q <sub>11</sub> to Q <sub>13</sub>	counter outputs
7, 5, 4, 6, 14, 13, 15	Q <sub>3</sub> to Q <sub>9</sub>	counter outputs
8	GND	ground (0 V)
9	C <sub>TC</sub>	external capacitor connection
10	R <sub>TC</sub>	external resistor connection
11	RS	clock input/oscillator pin
12	MR	master reset
16	V <sub>CC</sub>	positive supply voltage

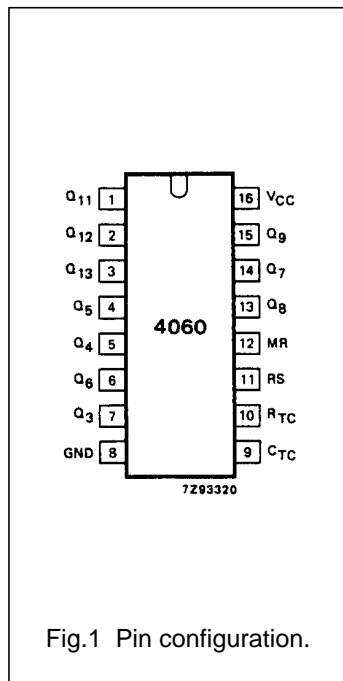

Fig.1 Pin configuration.

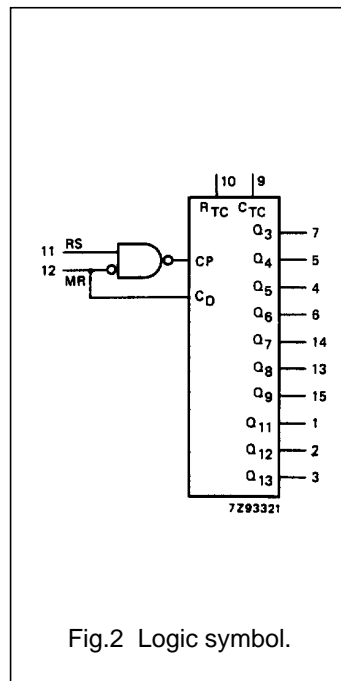

Fig.2 Logic symbol.

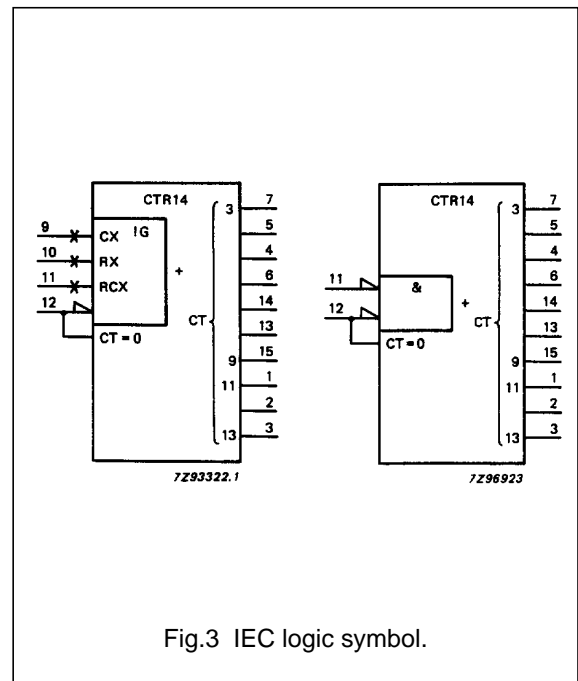

Fig.3 IEC logic symbol.

# 14-stage binary ripple counter with oscillator

# 74HC/HCT4060

## DYNAMIC POWER DISSIPATION FOR 74HC

PARAMETER	V <sub>CC</sub> (V)	TYPICAL FORMULA FOR P <sub>D</sub> (μW) (note 1)
total dynamic power	2.0	$C_{PD} \times f_{osc} \times V_{CC}^2 + \sum (C_L \times V_{CC}^2 \times f_o) + 2C_t \times V_{CC}^2 \times f_{osc} + 60 \times V_{CC}$
dissipation when using the on-chip oscillator (P <sub>D</sub> )	4.5	$C_{PD} \times f_{osc} \times V_{CC}^2 + \sum (C_L \times V_{CC}^2 \times f_o) + 2C_t \times V_{CC}^2 \times f_{osc} + 1\,750 \times V_{CC}$
	6.0	$C_{PD} \times f_{osc} \times V_{CC}^2 + \sum (C_L \times V_{CC}^2 \times f_o) + 2C_t \times V_{CC}^2 \times f_{osc} + 3\,800 \times V_{CC}$

**Note**

- GND = 0 V; T<sub>amb</sub> = 25 °C

## DYNAMIC POWER DISSIPATION FOR 74HCT

PARAMETER	V <sub>CC</sub> (V)	TYPICAL FORMULA FOR P <sub>D</sub> (μW) (note 1)
total dynamic power dissipation when using the on-chip oscillator (P <sub>D</sub> )	4.5	$C_{PD} \times f_{osc} \times V_{CC}^2 + \sum (C_L \times V_{CC}^2 \times f_o) + 2C_t \times V_{CC}^2 \times f_{osc} + 1\,750 \times V_{CC}$

**Notes**

- GND = 0 V; T<sub>amb</sub> = 25 °C
- Where: f<sub>o</sub> = output frequency in MHz  
 f<sub>osc</sub> = oscillator frequency in MHz  
 $\sum (C_L \times V_{CC}^2 \times f_o)$  = sum of outputs  
 C<sub>L</sub> = output load capacitance in pF  
 C<sub>t</sub> = timing capacitance in pF  
 V<sub>CC</sub> = supply voltage in V

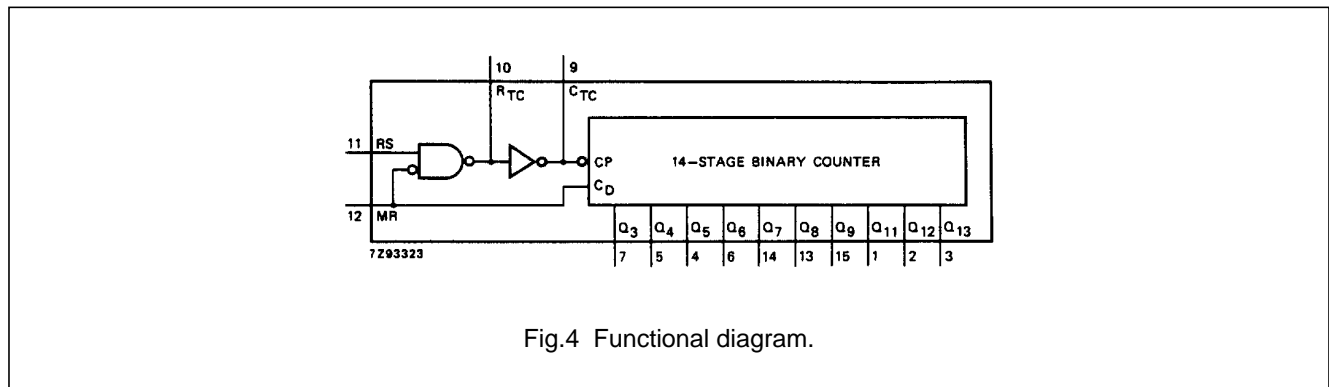

Fig.4 Functional diagram.

## APPLICATIONS

- Control counters
- Timers
- Frequency dividers
- Time-delay circuits

# 14-stage binary ripple counter with oscillator

74HC/HCT4060

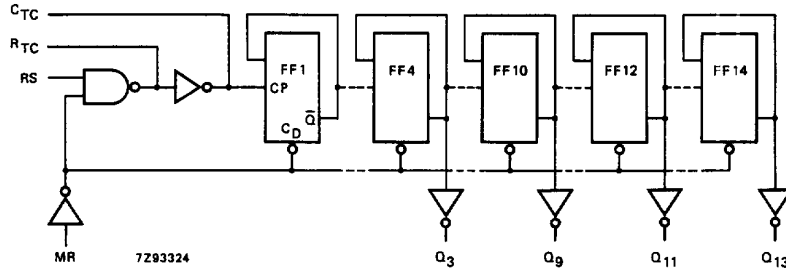

Fig.5 Logic diagram.

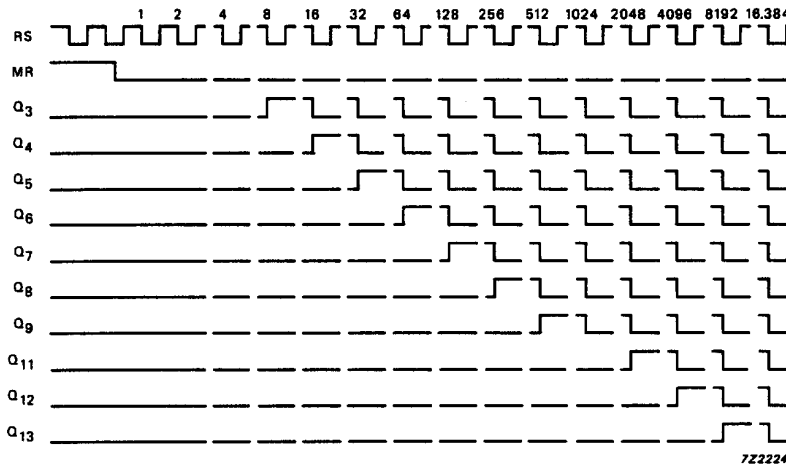

Fig.6 Timing diagram.

## 14-stage binary ripple counter with oscillator

## 74HC/HCT4060

**DC CHARACTERISTICS FOR 74HC**Output capability: standard (except for  $R_{TC}$  and  $C_{TC}$ ) $I_{CC}$  category: MSI

Voltages are referenced to GND (ground = 0 V)

SYM-BOL	PARAMETER	$T_{amb}$ (°C)							UNIT	TEST CONDITIONS		
		74HC								$V_{CC}$ (V)	$V_I$	OTHER
		+25			-40 to +85		-40 to +125					
		min.	typ.	max.	min.	max.	min.	max.				
$V_{IH}$	HIGH level input voltage MR input	1.5 3.15 4.2	1.3 2.4 3.1		1.5 3.15 4.2		1.5 3.15 4.2		V	2.0 4.5 6.0		
$V_{IL}$	LOW level input voltage MR input		0.8 2.1 2.8	0.5 1.35 1.8		0.5 1.35 1.8	0.5 1.35 1.8		V	2.0 4.5 6.0		
$V_{IH}$	HIGH level input voltage RS input	1.7 3.6 4.8			1.7 3.6 4.8		1.7 3.6 4.8		V	2.0 4.5 6.0		
$V_{IL}$	LOW level input voltage RS input			0.3 0.9 1.2		0.3 0.9 1.2	0.3 0.9 1.2		V	2.0 4.5 6.0		
$V_{OH}$	HIGH level output voltage $R_{TC}$ output	3.98 5.48			3.84 5.34		3.7 5.2		V	4.5 6.0	RS=GND and MR=GND	$-I_O = 2.6$ mA $-I_O = 3.3$ mA
		3.98 5.48			3.84 5.34		3.7 5.2		V	4.5 6.0	RS= $V_{CC}$ and MR= $V_{CC}$	$-I_O = 0.65$ mA $-I_O = 0.85$ mA
		1.9 4.4 5.9	2.0 4.5 6.0		1.9 4.4 5.9		1.9 4.4 5.9		V	2.0 4.5 6.0	RS=GND and MR=GND	$-I_O = 20$ $\mu$ A $-I_O = 20$ $\mu$ A $-I_O = 20$ $\mu$ A
		1.9 4.4 5.9	2.0 4.5 6.0		1.9 4.4 5.9		1.9 4.4 5.9		V	2.0 4.5 6.0	RS= $V_{CC}$ and MR= $V_{CC}$	$-I_O = 20$ $\mu$ A $-I_O = 20$ $\mu$ A $-I_O = 20$ $\mu$ A
$V_{OH}$	HIGH level output voltage $C_{TC}$ output	3.98 5.48			3.84 5.34		3.7 5.2		V	4.5 6.0	RS= $V_{IH}$ and MR= $V_{IL}$	$-I_O = 3.2$ mA $-I_O = 4.2$ mA
$V_{OH}$	HIGH level output voltage except $R_{TC}$ output	1.9 4.4 5.9	2.0 4.5 6.0		1.9 4.4 5.9		1.9 4.4 5.9		V	2.0 4.5 6.0	$V_{IH}$ or $V_{IL}$	$-I_O = 20$ $\mu$ A $-I_O = 20$ $\mu$ A $-I_O = 20$ $\mu$ A
$V_{OH}$	HIGH level output voltage except $R_{TC}$ and $C_{TC}$ outputs	3.98 5.48			3.84 5.34		3.7 5.2		V	4.5 6.0	$V_{IH}$ or $V_{IL}$	$-I_O = 4.0$ mA $-I_O = 5.2$ mA
$V_{OL}$	LOW level output voltage $R_{TC}$ output			0.26 0.26		0.33 0.33	0.4 0.4			4.5 6.0	RS= $V_{CC}$ and MR=GND	$I_O = 2.6$ mA $I_O = 3.3$ mA
			0 0 0	0.1 0.1 0.1		0.1 0.1 0.1	0.1 0.1 0.1		V	2.0 4.5 6.0	RS= $V_{CC}$ and MR=GND	$I_O = 20$ $\mu$ A $I_O = 20$ $\mu$ A $I_O = 20$ $\mu$ A

## 14-stage binary ripple counter with oscillator

## 74HC/HCT4060

SYM-BOL	PARAMETER	T <sub>amb</sub> (°C)							UNIT	TEST CONDITIONS		
		74HC								V <sub>CC</sub> (V)	V <sub>I</sub>	OTHER
		+25			-40 to +85		-40 to +125					
		min.	typ.	max.	min.	max.	min.	max.				
V <sub>OL</sub>	LOW level output voltage C <sub>TC</sub> output			0.26 0.26		0.33 0.33		0.4 0.4	V	4.5 6.0	RS=V <sub>IL</sub> and MR=V <sub>IH</sub>	I <sub>O</sub> = 3.2 mA I <sub>O</sub> = 4.2 mA
V <sub>OL</sub>	LOW level output voltage except R <sub>TC</sub> output		0 0 0	0.1 0.1 0.1		0.1 0.1 0.1		0.1 0.1 0.1	V	2.0 4.5 6.0	V <sub>IH</sub> or V <sub>IL</sub>	I <sub>O</sub> = 20 μA I <sub>O</sub> = 20 μA I <sub>O</sub> = 20 μA
V <sub>OL</sub>	LOW level output voltage except R <sub>TC</sub> and C <sub>TC</sub> outputs			0.26 0.26		0.33 0.33		0.4 0.4	V	4.5 6.0	V <sub>IH</sub> or V <sub>IL</sub>	I <sub>O</sub> = 4.0 mA I <sub>O</sub> = 5.2 mA
±I <sub>I</sub>	input leakage current			0.1		1.0		1.0	μA	6.0	V <sub>CC</sub> or GND	
I <sub>CC</sub>	quiescent supply current			8.0		80.0		160.0	μA	6.0	V <sub>CC</sub> or GND	I <sub>O</sub> = 0

## 14-stage binary ripple counter with oscillator

## 74HC/HCT4060

**AC CHARACTERISTICS FOR 74HC**GND = 0 V;  $t_r = t_f = 6$  ns;  $C_L = 50$  pF

SYMBOL	PARAMETER	T <sub>amb</sub> (°C)						UNIT	TEST CONDITIONS		
		74HC							V <sub>CC</sub> (V)	WAVEFORMS	
		+25			-40 to +85		-40 to +125				
		min.	typ.	max.	min.	max.	min.				max.
t <sub>PHL</sub> / t <sub>PLH</sub>	propagation delay RS to Q <sub>3</sub>		99 36 29	300 60 51		375 75 64		450 90 77	ns	2.0 4.5 6.0	Fig.12
t <sub>PHL</sub> / t <sub>PLH</sub>	propagation delay Q <sub>n</sub> to Q <sub>n+1</sub>		22 8 6	80 16 14		100 20 17		120 24 20	ns	2.0 4.5 6.0	Fig.14
t <sub>PHL</sub>	propagation delay MR to Q <sub>n</sub>		55 20 16	175 35 30		220 44 37		265 53 45	ns	2.0 4.5 6.0	Fig.13
t <sub>THL</sub> / t <sub>TLH</sub>	output transition time		19 7 6	75 15 13		95 19 16		110 22 19	ns	2.0 4.5 6.0	Fig.12
t <sub>w</sub>	clock pulse width RS; HIGH or LOW	80 16 14	17 6 5		100 20 17		120 24 20		ns	2.0 4.5 6.0	Fig.12
t <sub>w</sub>	master reset pulse width MR; HIGH	80 16 14	25 9 7		100 20 17		120 24 20		ns	2.0 4.5 6.0	Fig.13
t <sub>rem</sub>	removal time MR to RS	100 20 17	28 10 8		125 25 21		150 30 26		ns	2.0 4.5 6.0	Fig.13
f <sub>max</sub>	maximum clock pulse frequency	6.0 30 35	26 80 95		4.8 24 28		4.0 20 24		MHz	2.0 4.5 6.0	Fig.12



## 14-stage binary ripple counter with oscillator

## 74HC/HCT4060

## DC CHARACTERISTICS FOR 74HCT

Output capability: standard (except for  $R_{TC}$  and  $C_{TC}$ ) $I_{CC}$  category: MSI

Voltages are referenced to GND (ground = 0 V)

SYMBOL	PARAMETER	$T_{amb}$ (°C)								UNIT	TEST CONDITIONS		
		74HCT									$V_{CC}$ (V)	$V_I$	OTHER
		+25			-40 to +85		-40 to +125						
		min.	typ.	max.	min.	max.	min.	max.					
$V_{IH}$	HIGH level input voltage	2.0			2.0		2.0		V	4.5 to 5.5		note 2	
$V_{IL}$	LOW level input voltage			0.8		0.8		0.8	V	4.5 to 5.5		note 2	
$V_{OH}$	HIGH level output voltage $R_{TC}$ output	3.98			3.84		3.7		V	4.5	RS=GND and MR=GND	$-I_O = 2.6$ mA	
		3.98			3.84		3.7		V	4.5	RS = $V_{CC}$ and MR = $V_{CC}$	$-I_O = 0.65$ mA	
		4.4	4.5		4.4		4.4		V	4.5	RS=GND and MR=GND	$-I_O = 20$ $\mu$ A	
		4.4	4.5		4.4		4.4		V	4.5	RS= $V_{CC}$ and MR= $V_{CC}$	$-I_O = 20$ $\mu$ A	
$V_{OH}$	HIGH level output voltage $C_{TC}$ output	3.98			3.84		3.7		V	4.5	RS = $V_{IH}$ and MR = $V_{IL}$	$-I_O = 3.2$ mA	
$V_{OH}$	HIGH level output voltage except $R_{TC}$ output	4.4	4.5		4.4		4.4		V	4.5	$V_{IH}$ or $V_{IL}$	$-I_O = 20$ $\mu$ A	
$V_{OH}$	HIGH level output voltage except $R_{TC}$ and $C_{TC}$ outputs	3.98			3.84		3.7		V	4.5	$V_{IH}$ or $V_{IL}$	$-I_O = 4.0$ mA	
$V_{OL}$	LOW level output voltage $R_{TC}$ output			0.26		0.33		0.4	V	4.5	RS= $V_{CC}$ and MR=GND	$I_O = 2.6$ mA	
			0	0.1		0.1		0.1	V	4.5	RS= $V_{CC}$ and MR=GND	$I_O = 20$ $\mu$ A	
$V_{OL}$	LOW level output voltage $C_{TC}$ output			0.26		0.33		0.4	V	4.5	RS = $V_{IL}$ and MR = $V_{IH}$	$I_O = 3.2$ mA	
$V_{OL}$	LOW level output voltage except $R_{TC}$ output		0	0.1		0.1		0.1	V	4.5	$V_{IH}$ or $V_{IL}$	$I_O = 20$ $\mu$ A	
$V_{OL}$	LOW level output voltage except $R_{TC}$ and $C_{TC}$ outputs			0.26		0.33		0.4	V	4.5	$V_{IH}$ or $V_{IL}$	$I_O = 4.0$ mA	
$\pm I$	input leakage current			0.1		1.0		1.0	$\mu$ A	5.5	$V_{CC}$ or GND		
$I_{CC}$	quiescent supply current			8.0		80.0		160.0	$\mu$ A	5.5	$V_{CC}$ or GND	$I_O = 0$	
$\Delta I_{CC}$	additional quiescent supply current per input pin for unit load coefficient is 1 (note 1)		100	360		450		490	$\mu$ A	4.5 to 5.5	$V_{CC} - 2.1$ V	other inputs at $V_{CC}$ or GND; $I_O = 0$	

## 14-stage binary ripple counter with oscillator

## 74HC/HCT4060

**Notes**

- The value of additional quiescent supply current ( $\Delta I_{CC}$ ) for a unit load of 1 is given here.  
To determine  $\Delta I_{CC}$  per input, multiply this value by the unit load coefficient shown in the table below.
- Only input MR (pin 12) has TTL input switching levels for the HCT versions.

INPUT	UNIT LOAD COEFFICIENT
MR	0.40

**AC CHARACTERISTICS FOR 74HCT**GND = 0 V;  $t_r = t_f = 6$  ns;  $C_L = 50$  pF

SYMBOL	PARAMETER	$T_{amb}$ (°C)								UNIT	TEST CONDITIONS	
		74HCT									$V_{CC}$ (V)	WAVEFORMS
		+25			-40 to +85		-40 to +125					
		min.	typ.	max.	min.	max.	min.	max.				
$t_{PHL}/t_{PLH}$	propagation delay RS to $Q_3$		33	66		83		99	ns	4.5	Fig.12	
$t_{PHL}/t_{PLH}$	propagation delay $Q_n$ to $Q_{n+1}$		8	16		20		24	ns	4.5	Fig.14	
$t_{PHL}$	propagation delay MR to $Q_n$		21	44		55		66	ns	4.5	Fig.13	
$t_{THL}/t_{TLH}$	output transition time		7	15		19		22	ns	4.5	Fig.12	
$t_W$	clock pulse width RS; HIGH or LOW	16	6		20		24		ns	4.5	Fig.12	
$t_W$	master reset pulse width MR; HIGH	16	6		20		24		ns	4.5	Fig.13	
$t_{rem}$	removal time MR to RS	26	13		33		39		ns	4.5	Fig.13	
$f_{max}$	maximum clock pulse frequency	30	80		24		20		MHz	4.5	Fig.12	

14-stage binary ripple counter with oscillator

74HC/HCT4060

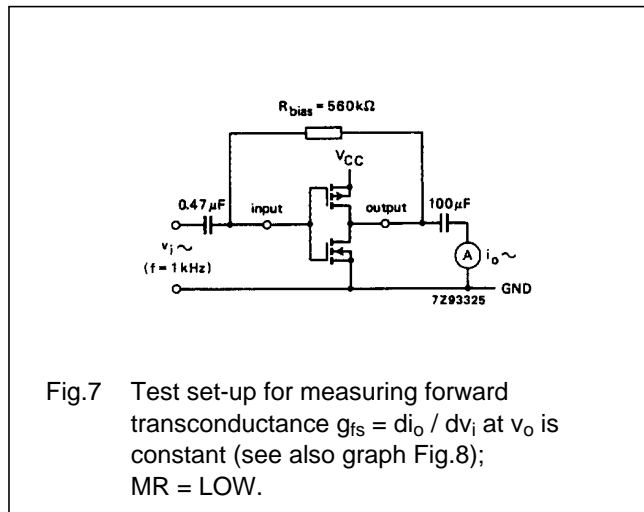

Fig.7 Test set-up for measuring forward transconductance  $g_{fs} = di_o / dv_i$  at  $v_o$  is constant (see also graph Fig.8); MR = LOW.

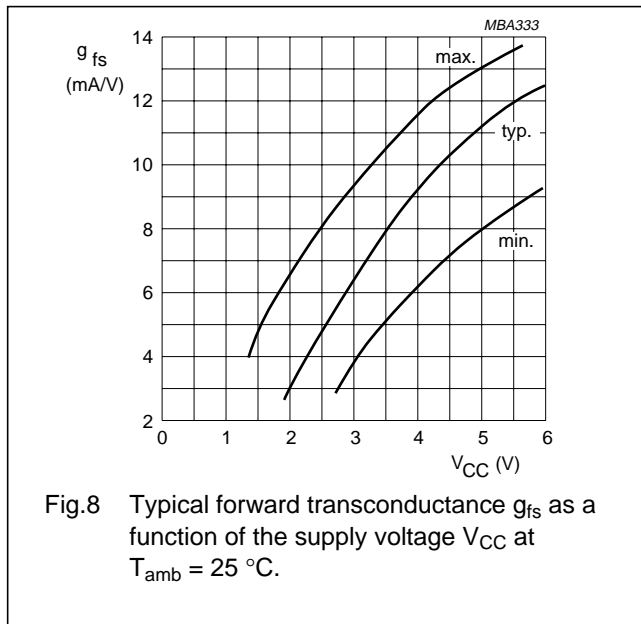

Fig.8 Typical forward transconductance  $g_{fs}$  as a function of the supply voltage  $V_{CC}$  at  $T_{amb} = 25 \text{ }^\circ\text{C}$ .

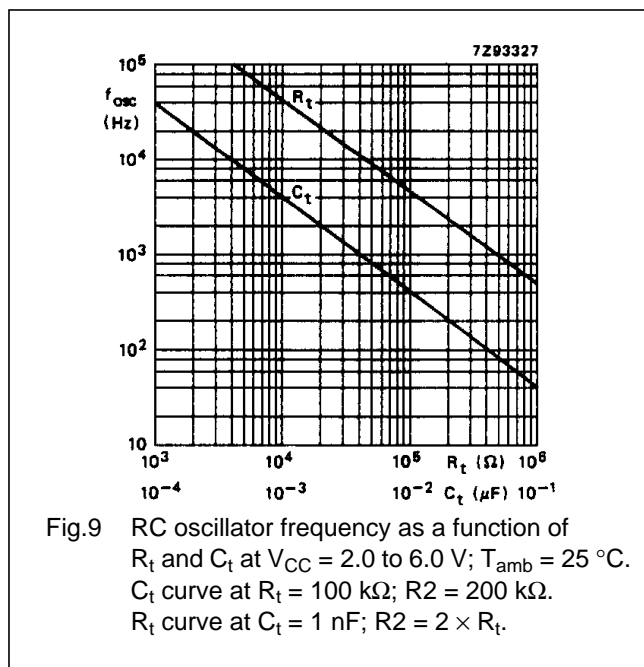
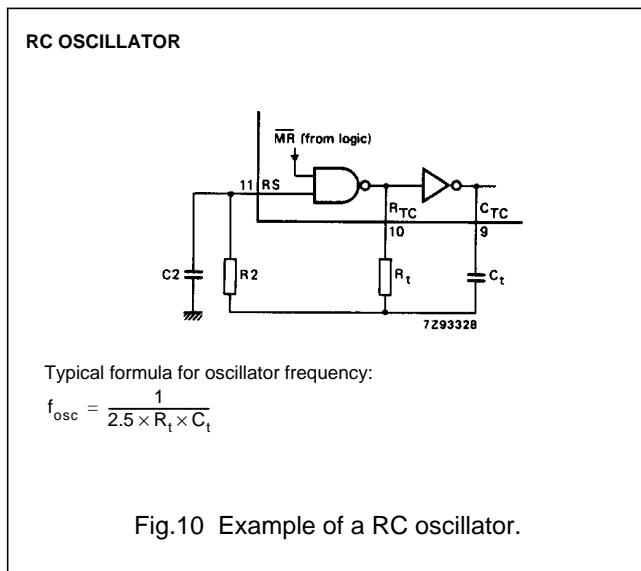

Fig.9 RC oscillator frequency as a function of  $R_t$  and  $C_t$  at  $V_{CC} = 2.0$  to  $6.0$  V;  $T_{amb} = 25 \text{ }^\circ\text{C}$ .  $C_t$  curve at  $R_t = 100$  kΩ;  $R_2 = 200$  kΩ.  $R_t$  curve at  $C_t = 1$  nF;  $R_2 = 2 \times R_t$ .



Typical formula for oscillator frequency:  

$$f_{osc} = \frac{1}{2.5 \times R_t \times C_t}$$

Fig.10 Example of a RC oscillator.

**TIMING COMPONENT LIMITATIONS**

The oscillator frequency is mainly determined by  $R_t C_t$ , provided  $R_2 \approx 2R_t$  and  $R_2 C_2 \ll R_t C_t$ . The function of  $R_2$  is to minimize the influence of the forward voltage across the input protection diodes on the frequency. The stray capacitance  $C_2$  should be kept as small as possible. In consideration of accuracy,  $C_t$  must be larger than the inherent stray capacitance.  $R_t$  must be larger than the "ON" resistance in series with it, which typically is 280 Ω at  $V_{CC} = 2.0$  V, 130 Ω at  $V_{CC} = 4.5$  V and 100 Ω at  $V_{CC} = 6.0$  V.

The recommended values for these components to maintain agreement with the typical oscillation formula are:

- $C_t > 50$  pF, up to any practical value,
- $10$  kΩ  $< R_t < 1$  MΩ.

In order to avoid start-up problems,  $R_t \geq 1$  kΩ.

# 14-stage binary ripple counter with oscillator

# 74HC/HCT4060

### TYPICAL CRYSTAL OSCILLATOR

In Fig.11, R2 is the power limiting resistor. For starting and maintaining oscillation a minimum transconductance is necessary, so R2 should not be too large. A practical value for R2 is 2.2 kΩ.

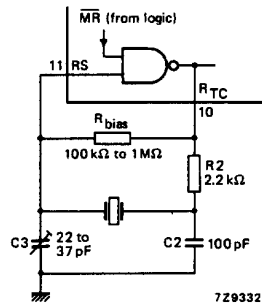
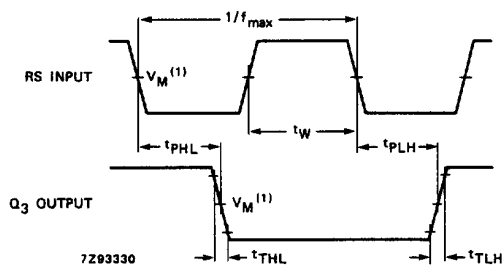

Fig.11 External components connection for a crystal oscillator.

### AC WAVEFORMS



(1) HC :  $V_M = 50\%$ ;  $V_I = \text{GND to } V_{CC}$ .  
 HCT:  $V_M = 1.3 \text{ V}$ ;  $V_I = \text{GND to } 3 \text{ V}$ .

Fig.12 Waveforms showing the clock (RS) to output ( $Q_3$ ) propagation delays, the clock pulse width, the output transition times and the maximum clock frequency.

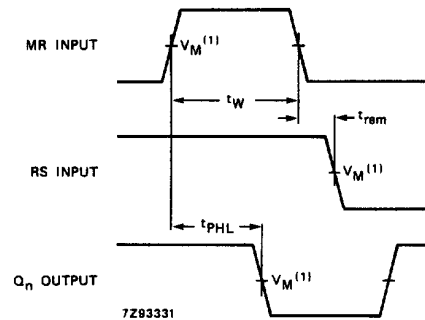

(1) HC :  $V_M = 50\%$ ;  $V_I = \text{GND to } V_{CC}$ .  
 HCT:  $V_M = 1.3 \text{ V}$ ;  $V_I = \text{GND to } 3 \text{ V}$ .

Fig.13 Waveforms showing the master reset (MR) pulse width, the master reset to output ( $Q_n$ ) propagation delays and the master reset to clock (RS) removal time.

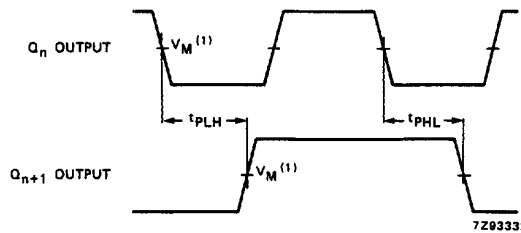

(1) HC :  $V_M = 50\%$ ;  $V_I = \text{GND to } V_{CC}$ .  
 HCT:  $V_M = 1.3 \text{ V}$ ;  $V_I = \text{GND to } 3 \text{ V}$ .

Fig.14 Waveforms showing the output ( $Q_n$ ) to  $Q_{n+1}$  propagation delays.

### PACKAGE OUTLINES

See "74HC/HCT/HCU/HCMOS Logic Package Outlines".

# 74HC/HCT4060; 14-stage binary ripple counter with oscillator

Information as of 2003-04-22

My.Semiconductors.COM.  
Your personal service from Philips Semiconductors.  
Please register now !

Use right mouse button to download datasheet

Download datasheet

Stay informed

- [Products](#)
- [MultiMarket Semiconductors](#)
- [Product Selector](#)
- [Catalog by Function](#)
- [Catalog by System](#)
- [Cross-reference](#)
- [Packages](#)
- [End of Life information](#)
- [Distributors Go Here!](#)
- [Models](#)
- [SoC solutions](#)

<a href="#">General description</a>	<a href="#">Features</a>	<a href="#">Applications</a>	<a href="#">Datasheet</a>
<a href="#">Block diagram</a>	<a href="#">Buy online</a>	<a href="#">Support &amp; tools</a>	<a href="#">Email/translate</a>
<a href="#">Products &amp; packages</a>	<a href="#">Parametrics</a>	<a href="#">Similar products</a>	

## General description

The 74HC/HCT4060 are high-speed Si-gate CMOS devices and are pin compatible with '4060' of the '4000B' series. They are specified in compliance with JEDEC standard no. 7A.

The 74HC/HCT4060 are 14-stage ripple-carry counter/dividers and oscillators with three oscillator terminals (RS, R<sub>TC</sub> and C<sub>TC</sub>), ten buffered outputs (Q<sub>3</sub> to Q<sub>9</sub> and Q<sub>11</sub> to Q<sub>13</sub>) and an overriding asynchronous master reset (MR).

The oscillator configuration allows design of either RC or crystal oscillator circuits. The oscillator may be replaced by an external clock signal at input RS. In this case keep the other oscillator pins (R<sub>TC</sub> and C<sub>TC</sub>) floating.

The counter advances on the negative-going transition of RS. A HIGH level on MR resets the counter (Q<sub>3</sub> to Q<sub>9</sub> and Q<sub>11</sub> to Q<sub>13</sub> = LOW), independent of other input conditions.

In the HCT version, the MR input is TTL compatible, but the RS input has CMOS input switching levels and can be driven by a TTL output by using a pull-up resistor to V<sub>CC</sub>.

## Features



- All active components on chip
- RC or crystal oscillator configuration
- Output capability: standard (except for R<sub>TC</sub> and C<sub>TC</sub>)
- I<sub>CC</sub> category: MSI

## Datasheet

Type number	Title	Publication release date	Datasheet status	Page count	File size (kB)	Datasheet
74HC/HCT4060	14-stage binary ripple counter with oscillator	12/1/1990	Product specification	12	81	<a href="#">Download</a>

Additional datasheet info













To complete the device datasheet with package and family information, also download the following PDF files. The "Logic Package Information" document is required to determine in which package(s) this device is available.

Document	Description
1  <a href="#">HCT_FAMILY_SPECIFICATIONS</a>	HC/T Family Specifications, The IC06 74HC/HCT/HCMOS Logic Family Specifications
2  <a href="#">HCT_PACKAGE_INFO</a>	HC/T Package Info, The IC06 74HC/HCT/HCMOS Logic Package Information
3  <a href="#">HCT_PACKAGE_OUTLINES</a>	HC/T Package Outlines, The IC06 74HC/HCT/HCMOS Logic Package Outlines

## Parametrics

Type number	Package	Description	Propagation Delay(ns)	Voltage	No. of Pins	Power Dissipation Considerations	Logic Switching Levels	Output Drive Capability
74HC4060D	<a href="#">SOT109</a> (SO16)	14-Stage Ripple-Carry Binary Counter/Divider and Oscillator	15	5 Volts +	16	Low Power or Battery Applications	CMOS	Low
74HC4060DB	<a href="#">SOT338-1</a> (SSOP16)	14-Stage Ripple-Carry Binary Counter/Divider and Oscillator	15	5 Volts +	16	Low Power or Battery Applications	CMOS	Low
74HC4060N	<a href="#">SOT38-1</a> (DIP16)	14-Stage Ripple-Carry Binary Counter/Divider and Oscillator	15	5 Volts +	16	Low Power or Battery Applications	CMOS	Low
74HC4060PW	<a href="#">SOT403-1</a> (TSSOP16)	14-Stage Ripple-Carry Binary Counter/Divider and Oscillator	15	5 Volts +	16	Low Power or Battery Applications	CMOS	Low
74HCT4060D	<a href="#">SOT109</a> (SO16)	14-Stage Ripple-Carry Binary Counter/Divider and Oscillator; TTL Enabled	15	5 Volts +	16	Low Power or Battery Applications	TTL	Low
74HCT4060DB	<a href="#">SOT338-1</a> (SSOP16)	14-Stage Ripple-Carry Binary Counter/Divider and Oscillator; TTL Enabled	15	5 Volts +	16	Low Power or Battery Applications	TTL	Low
74HCT4060N	<a href="#">SOT38-1</a> (DIP16)	14-Stage Ripple-Carry Binary Counter/Divider and Oscillator; TTL Enabled	15	5 Volts +	16	Low Power or Battery Applications	TTL	Low

## □ Products, packages, availability and ordering

<u>Type number</u>	<u>North American type number</u>	<u>Ordering code (12NC)</u>	<u>Marking/Packing</u>  <a href="#">Discretes packing info</a>	<u>Package</u>	<u>Device status</u>	<u>Buy online</u>
74HC4060D	74HC4060D	9337 140 10652	Standard Marking * Bulk Pack, CECC	<a href="#">SOT109</a> (SO16)	Full production	 -
	74HC4060D-T	9337 140 10653	Standard Marking * Reel Pack, SMD, 13", CECC	<a href="#">SOT109</a> (SO16)	Full production	 -
74HC4060DB	74HC4060DB	9351 875 00112	Standard Marking * Bulk Pack	<a href="#">SOT338-1</a> (SSOP16)	Full production	 -
	74HC4060DB-T	9351 875 00118	Standard Marking * Reel Pack, SMD, 13"	<a href="#">SOT338-1</a> (SSOP16)	Full production	 -
74HC4060N	74HC4060N	9336 697 70652	Standard Marking * Bulk Pack, CECC	<a href="#">SOT38-1</a> (DIP16)	Full production	 -
74HC4060PW	74HC4060PW	9352 420 80112	Standard Marking * Bulk Pack	<a href="#">SOT403-1</a> (TSSOP16)	Full production	 -
	74HC4060PW-T	9352 420 80118	Standard Marking * Reel Pack, SMD, 13"	<a href="#">SOT403-1</a> (TSSOP16)	Full production	 -
74HCT4060D	74HCT4060D	9337 140 20652	Standard Marking * Bulk Pack, CECC	<a href="#">SOT109</a> (SO16)	Full production	 -
	74HCT4060D-T	9337 140 20653	Standard Marking * Reel Pack, SMD, 13", CECC	<a href="#">SOT109</a> (SO16)	Full production	 -
74HCT4060DB	74HCT4060DB	9351 900 20112	Standard Marking * Bulk Pack	<a href="#">SOT338-1</a> (SSOP16)	Full production	 -
	74HCT4060DB-T	9351 900 20118	Standard Marking * Reel Pack, SMD, 13"	<a href="#">SOT338-1</a> (SSOP16)	Full production	 -
74HCT4060N	74HCT4060N	9336 704 00652	Standard Marking * Bulk Pack, CECC	<a href="#">SOT38-1</a> (DIP16)	Full production	 -

## □ Similar products

 [74HC/HCT4060](#) links to the similar products page containing an overview of products that are similar in function or related to the type number(s) as listed on this page. The similar products page includes products from the same catalog tree(s), relevant selection guides and products from the same functional category.

## □ Support & tools

 [HC/T Family Specifications, The IC06 74HC/HCT/HCMOS Logic Family Specifications](#)(date 01-Mar-98)  
 [HC/T User Guide](#)(date 01-Nov-97)

## □ Email/translate this product information

- [Email this product information.](#)
- Translate this product information page from English to:

The English language is the official language used at the [semiconductors.philips.com](http://semiconductors.philips.com) website and webpages. All translations on this website are created through the use of [Google Language Tools](#) and are provided for convenience purposes only. No rights can be derived from any translation on this website.

[About this Web Site](#)

| Copyright © 2003 Koninklijke Philips N.V. All rights reserved. | [Privacy Policy](#) |

| Koninklijke Philips N.V. | Access to and use of this Web Site is subject to the following [Terms of Use](#). |