

AZ DISPLAYS, INC.

COMPLETE LCD SOLUTIONS

SPECIFICATIONS FOR LIQUID CRYSTAL DISPLAY

PART NUMBER:

AGM1032A-FLW-FBH

REVISED:

October 17, 2007

REVISION RECORD

REVISION	REVISION DATE	PAGE	CONTENTS
VER1.0	17/10-2007		FIRST VERSION

※ **CONTENTS**

- 1.0 MECHANICAL DIAGRAM
- 2.0 MECHANICAL SPECS
- 3.0 ABSOLUTE MAXIMUM RATINGS
- 4.0 ELECTRICAL CHARACTERISTICS
- 5.0 OPTICAL CHARACTERISTICS
- 6.0 BLOCK DIAGRAM
- 7.0 PIN ASSIGNMENT
- 8.0 POWER SUPPLY
- 9.0 TIMING CHARACTERISTICS
- 10.0 RELIABILITY TEST
- 11.0 DISPLAY CONTROL INSTRUCTION
- 12.0 PRECAUTION FOR USING LCM

REV	ECN NO.	NATURE OF MODIFICATION	CN/DATE
A		First issued	24/10/07
A		Modified the BKL's dimension	17/12/07

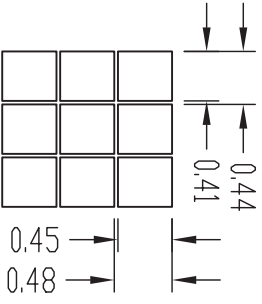
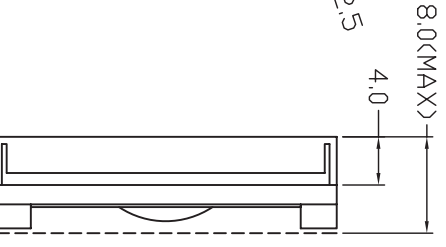
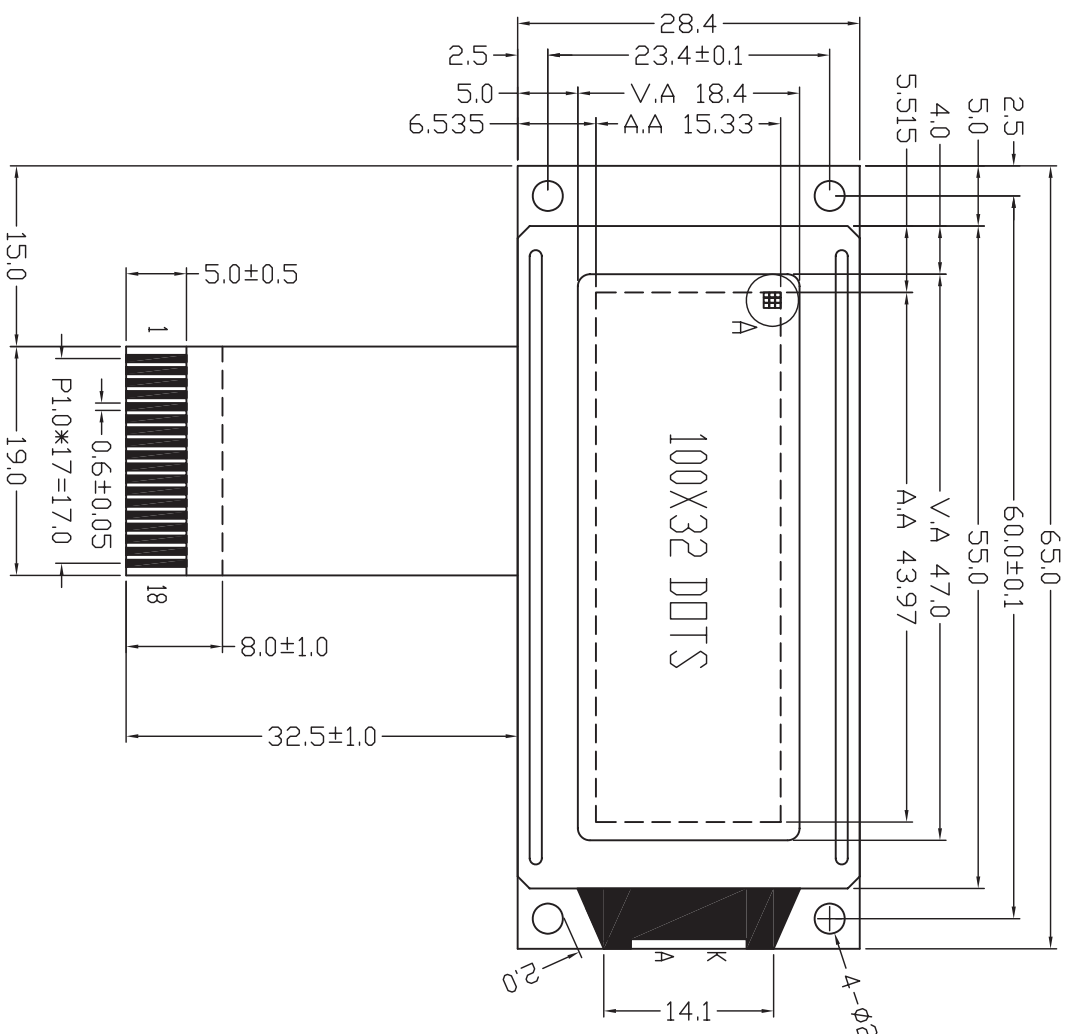

DETAIL A

PIN NO.	SYMBOL
18	LED-
17	LED+
16	DB7
15	DB6
14	DB5
13	DB4
12	DB3
11	DB2
10	DB1
9	DB0
8	NC
7	E2
6	E1
5	R/W
4	RS
3	Vo
2	Vdd
1	Vss

LCD SPECIFICATION

ITEM	PARAMETERS	ITEM	PARAMETERS
OPERATING VOLTAGE	5.0V	OPERATING TEMP	0°C TO 50°C
OPERATING CURRENT	..	STORAGE TEMP	-20°C TO 80°C
LOD DRIVING VOLTAGE	6.4V	POLARIZER TYPE	FRONT: TRANSMISSIVE
LOD DRIVING MODE	FS/IN POSITIVE	BACK: TRANSPARENT	White-LED (LIGHTS ON THE RIGHT)
LOD DRIVE METHOD	1/32 DUTY 1/6BIAS	BACKLIGHT	YES ■
LOD DRIVE IC	PT6920	ROHS STANDARD	OTHER
VIEW DIRECTION	8:00 O'CLOCK		

AZ Displays

UNIT	TOLERANCE
MM	X.X = ±0.2
3RD ANGLE	X.XX = ±0.10
ANG	= -

SCALE: 1:1

TITLE: **AGM1032A-ICM**

MODEL NO: **AGM1032A-F1W-FBH**

CHECKED: _____

APPROVED: _____

PART NO: --

REV **B**

2.0 MECHANICAL SPECS

Item	Description
1. Overall Module Size	65.0mm(W) x 28.4mm(H) x max 8.0mm(D)
2. Dot Size	0.41mm(W) x 0.45mm(H)
3. Dot Pitch	0.44mm(W) x 0.48mm(H)
4. Duty, BIAS	1/32 DUTY, 1/6 BIAS
5. LC Fluid	FSTN
6. Polarizer	Transflective, POSITIVE
7. Backlight	SIDE-LED, WHITE
8. Controller	PT6520

3.0 ABSOLUTE MAXIMUM RATINGS

Item	Symbol	Min	Typ	Max	Unit
Operating temperature (Wide temperature)	Top	0	-	50	°C
Storage temperature (Wide temperature)	Tst	-20	-	60	°C
Input voltage	Vin	Vss	-	Vdd	V
Supply voltage for logic	Vdd- Vss	-0.3	-	7.0	V
Supply voltage for LCD drive	Vdd- Vo	3.5	-	13.0	V

4.0 ELECTRICAL CHARACTERISTICS

Item	Symbol	Condition	Min	Typ	Max	Unit
Input voltage (high)	Vih	H level	0.8VDD	-	VDD	V
Input voltage (low)	Vil	L level	0	-	0.2VDD	V
Recommended LC Driving Voltage (Wide Temp)	Vdd -Vo	25°C	-	6.4	-	V
		-20°C	-	-	-	
Power Supply Current	Idd	Vdd=5.0V	-	-	3.0	mA
LED Power Supply Voltage	Vfled	IF=15 mA	2.9	3.1	3.3	V
LED Power Supply Current	Ifled	VF=3.1V	-	15	25	mA

5.0 OPTICAL CHARACTERISTICS

Item Mode		Cr (Contrast Ratio)		θ (Viewing Angle)		φ (Viewing Angle)	
		25°C		25°C		25°C	
		MIN.	TYP.	MIN	TYP.	MIN	TYP.
R	A	2.8	3.05	80°	85°	-	35°
	B	7.10	7.70	80°	85°	-	35°
	C	-	-	-	-	-	-
	A	2.49	2.99	80°	85°	-	35°

AGM1032A-FLW-FBH GRAPHIC MODULE VER1.0

S	B	7.05	7.55	80?	85?	-	35?
	C	5	8	-	70	-	35

Note:

- R: Reflective
- S: Transflective
- A: STN Gray
- B: STN Yellow
- C: FSTN

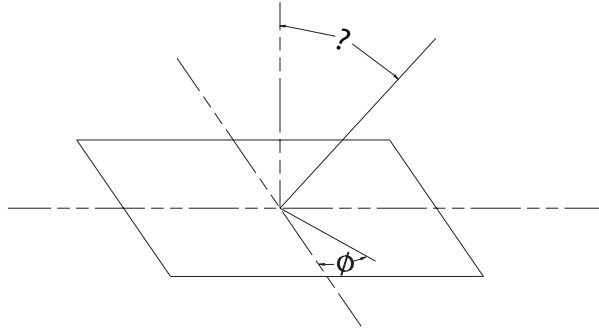

At: ? = 0?, ? = 0?

Item	Symbol	Condition	Min	Typ	Max	Unit
Response time (rise)	Tr	25 °C	-	200		ms
Response time (fall)	Tf	25°C	-	180		ms

6.0 BLOCK DIAGRAM

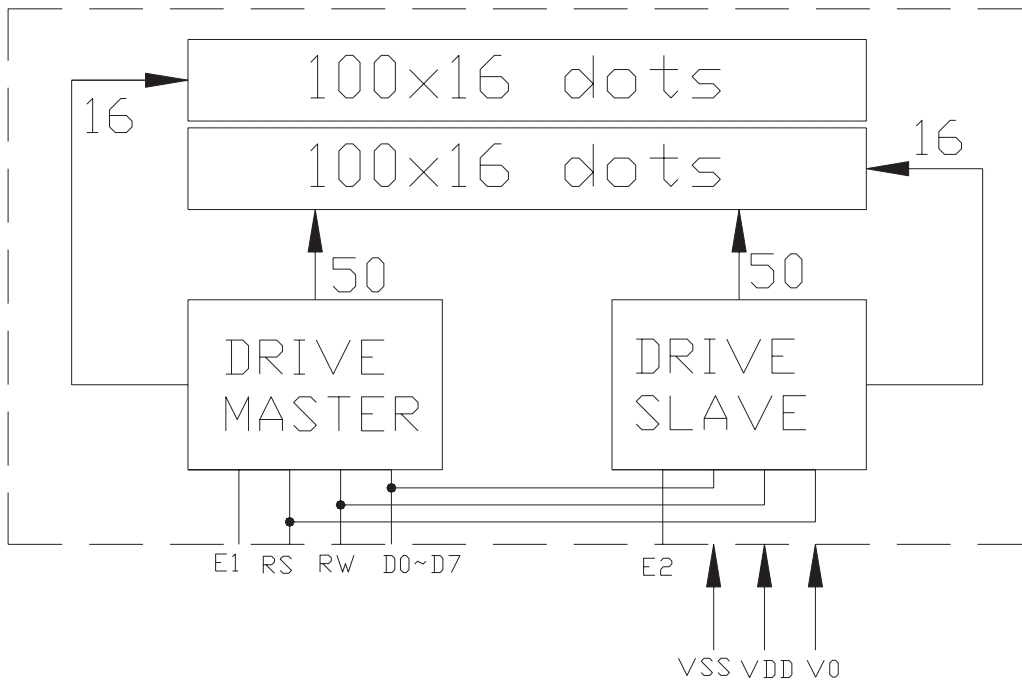

NOTE:

**BIAS RESISTOR SET: R1=R2=R4=R5=1K, R3=0
RES WITH R6=10K PULL-UP.
R7=1M.**

7.0 PIN ASSIGNMENT

Pin No.	Symbol	Function
1	VSS	Ground
2	VDD	Power Supply For Logic Circuit(+5V)
3	V0	Power Supply For LCD Driving
4	RS	Instruction Data Slect
5	RW	Read Write Slect
6	E1	Enable for IC1
7	E2	Enable for IC2
8	NC	No Connect
9	DB0	Data bit 0
10	DB1	Data bit 1
11	DB2	Data bit 2
12	DB3	Data bit 3
13	DB4	Data bit 4
14	DB5	Data bit 5
15	DB6	Data bit 6
16	DB7	Data bit 7
17	LED+	Power Supply For Backlight Circuit(3.1V)
18	LED-	Ground

8.0 POWER SUPPLY

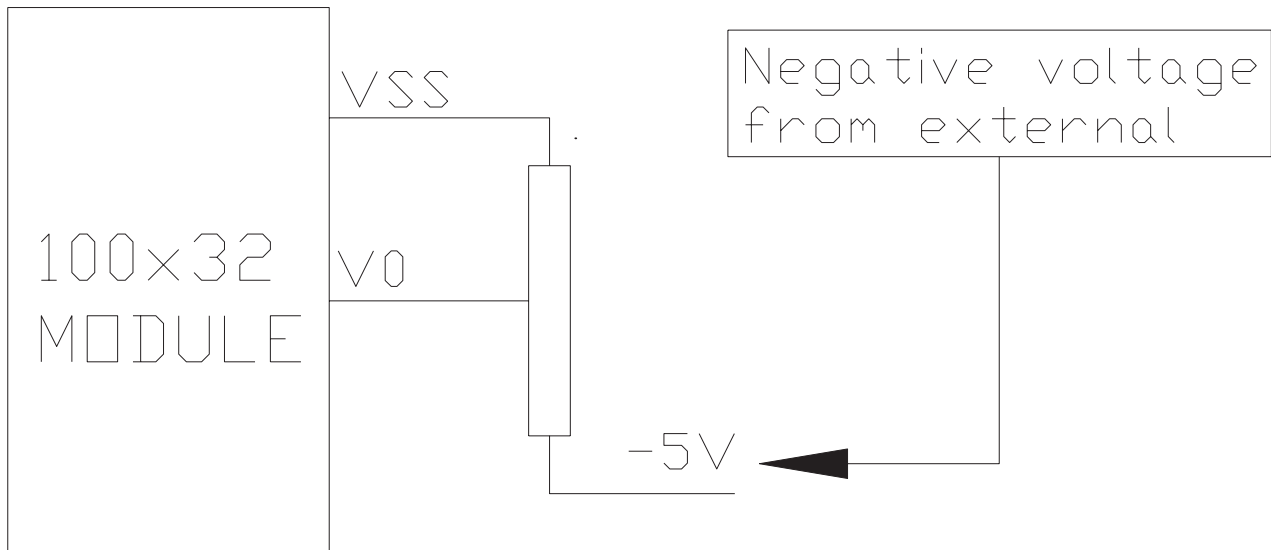

9.0 TIMING CHARACTERISTICS

Item	Svmbol	Test Condition	Min.	Tvp.	Max.	Unit
System cycle time	t_{CYC6}	Fig. a, Fig. b	1000	-	-	ns
Address setup time	t_{AW6}	Fig. a, Fig. b	20	-	-	ns
Address hold time	t_{AH6}	Fig. a, Fig. b	10	-	-	ns
Data hold time	t_{DH6}	Fig. a	10	-	-	ns
Data setup time	t_{DS6}	Fig. a	80	-	-	ns
Output disable time	t_{OH6}	CL=100 pF	10	-	60	ns
Access time	t_{ACC6}		-	-	90	
Enable pulsewidth	Read	T_{EW}	100			
	Write		80			
Rise and fall time	T_r, T_f	Fig. a, Fig. b	-	-	15	ns

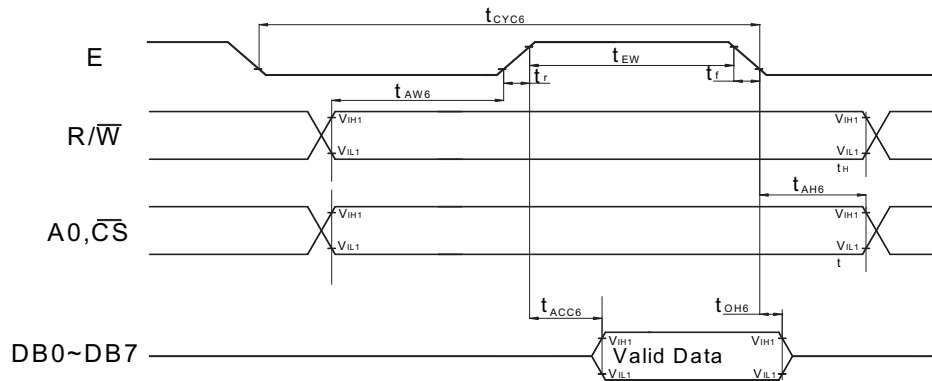

Fig. a Interface timing (data Read)

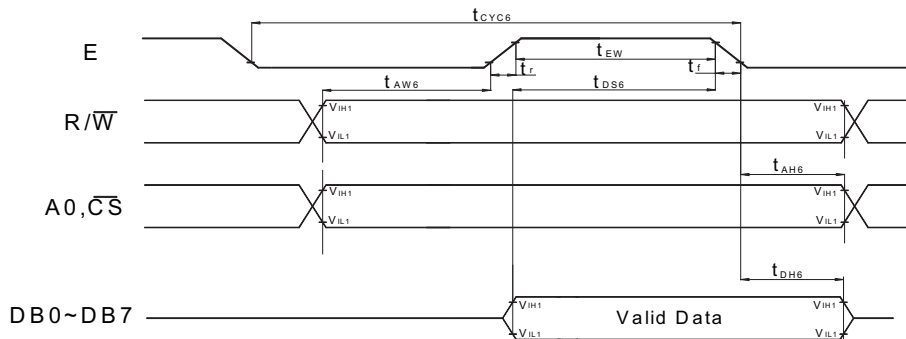

Fig. b Interface timing (data Write)

10.0 RELIABILITY TEST

Storage Condition	Content	Evaluations and Assessment*			
		Current Consumption	Oozing	Contrast	Other Appearances
Operation at high temperature and humidity	40°C,90% RH,120hrs	Twice initial value or less	none	More than 80% of initial value	No abnormality
High temperature storage	60°C, 120hrs	Twice initial value or less	none	More than 80% of initial value	No abnormality
Low temperature storage	-20°C, 120hrs	Twice initial value or less		More than 80% of initial value	No abnormality

*Evaluations and assessment to be made two hours after returning to room temperature (25°C±5°C).

*The LCDs subjected to the test must not have dew condensation.

11.0 DISPLAY CONTROL INSTRUCTION

The display control instructions control the internal state of the SED1520DOA/FOA. Instructions are received from MPU to SED1520DOA/FOA for the display control.

INSTRUCTION	A0	RD	R/W	DB7	DB6	DB5	DB4	DB3	DB2	DB1	DB0	DESCRIPTION
Display ON/OFF	0	1	0	1	0	1	0	1	1	1	1/0	Turns display on or off. 0: OFF. 1:ON
Set Page Address	0	1	0	1	0	1	1	1	0	Page (0~3)		Sets display RAM Page in Page address register
Set Column (Segment address)	0	1	0	0	Column address (0~79)						Sets display RAM column address in column address register	
Display Start Line	0	1	0	1	1	0	Display start line (0~31)					Indicates the display data RAM displayed at the top of the screen.
Status Read	0	0	1	BUSY	ADC	ON/OFF	RESET	0	0	0	0	Reads the following status: BUSY 0: Ready 1: Busy ADC 1: CW output 0: CCW output ON/OFF 0: Display on 1: Display off RESET 0: Normal 1: Being Reset
Write Display Data	1	1	0	Write Data								Writes data DB0~DB7 from bus into display data RAM.
Read Display Data	1	0	1	Read Data								Reads data DB0~DB7 from display data RAM onto the data bus.
Select ADC	0	1	0	1	0	1	0	0	0	0	0/1	0: CW output,1: CCW output

AGM1032A-FLW-FBH GRAPHIC MODULE VER1.0

Static drive ON/OFF	0	1	0	1	0	1	0	0	1	0	0/1	1: Static drive, 0: Normal driving
Select duty	0	1	0	1	0	1	0	1	0	0	0/1	Select LCD duty cycle 1:1/32, 0: 1/16
Read-Modify-Wreti	0	1	0	1	1	1	0	0	0	0	0	Read-Modify-write ON
END	0	1	0	1	1	1	0	1	1	1	0	Read-Modify-write OFF
Reset	0	1	0	1	1	1	0	0	0	1	0	Software reset

12.0 PRECAUTION FOR USING LCM

1. When design the product with this LCD Module, make sure the viewing angle matches to its purpose of usage.
2. As LCD panel is made of glass substrate, Dropping the LCD module or banging it against hard objects may cause cracking or fragmentation. Especially at corners and edges.
3. Although the polarizer of this LCD Module has the anti-glare coating, always be careful not to scratch its surface. Use of a plastic cover is recommended to protect the surface of polarizer.
4. If the LCD module is stored at below specified temperature, the LC material may freeze and be deteriorated. If it is stored at above specified temperature, the molecular orientation of the LC material may change to Liquid state and it may not revert to its original state. Excessive temperature and humidity could cause polarizer peel off or bubble. Therefore, the LCD module should always be stored within specified temperature range.
5. Saliva or water droplets must be wiped off immediately as those may leave stains or cause color changes if remained for a long time. Water vapor will cause corrosion of ITO electrodes.
6. If the surface of LCD panel needs to be cleaned, wipe it swiftly with cotton or other soft cloth. If it is not still clean enough, blow a breath on the surface and wipe again.
7. The module should be driven according to the specified ratings to avoid malfunction and permanent damage. Applying DC voltage cause a rapid deterioration of LC material. Make sure to apply alternating waveform by continuous application of the M signal. Especially the power ON/OFF sequence should be kept to avoid latch-up of driver LSIs and DC charge up to LCD panel.
8. Mechanical Considerations
 - a) LCM are assembled and adjusted with a high degree of precision. Avoid excessive shocks and do not make any alterations or modifications. The following should be noted.
 - b) Do not tamper in any way with the tabs on the metal frame.
 - c) Do not modify the PCB by drilling extra holes, changing its outline, moving its components or modifying its pattern.
 - d) Do not touch the elastomer connector; especially insert a backlight panel (for example, EL).
 - e) When mounting a LCM makes sure that the PCB is not under any stress such as bending or twisting. Elastomer contacts are very delicate and missing pixels could result from slight dislocation of any of the elements.
 - f) Avoid pressing on the metal bezel, otherwise the elastomer connector could be deformed and lose contact, resulting in missing pixels.
9. Static Electricity
 - a) Operator

Wear the electrostatics shielded clothes because human body may be statically charged if not wear shielded clothes. Never touch any of the conductive parts such as the LSI pads; the copper leads on the PCB and the interface terminals with any parts of the human body.

b) Equipment

There is a possibility that the static electricity is charged to the equipment, which has a function of peeling or friction action (ex: conveyer, soldering iron, working table). Earth the equipment through proper resistance (electrostatic earth: 1×10^9 ohm).

Only properly grounded soldering irons should be used.

If an electric screwdriver is used, it should be well grounded and shielded from commutator sparks.

The normal static prevention measures should be observed for work clothes and working benches; for the latter conductive (rubber) mat is recommended.

c) Floor

Floor is the important part to drain static electricity, which is generated by operators or equipment.

There is a possibility that charged static electricity is not properly drained in case of insulating floor. Set the electrostatic earth (electrostatic earth: 1×10^8 ohm).

d) Humidity

Proper humidity helps in reducing the chance of generating electrostatic charges. Humidity should be kept over 50%RH.

e) Transportation/storage

The storage materials also need to be anti-static treated because there is a possibility that the human body or storage materials such as containers may be statically charged by friction or peeling.

The modules should be kept in antistatic bags or other containers resistant to static for storage.

f) Soldering

Solder only to the I/O terminals. Use only soldering irons with proper grounding and no leakage.

Soldering temperature : $280^{\circ} \text{C} \pm 10^{\circ} \text{C}$

Soldering time: 3 to 4 sec.

Use eutectic solder with resin flux fill.

If flux is used, the LCD surface should be covered to avoid flux spatters. Flux residue should be removed afterwards.

g) Others

The laminator (protective film) is attached on the surface of LCD panel to prevent it from scratches or stains. It should be peeled off slowly using static eliminator.

Static eliminator should also be installed to the workbench to prevent LCD module from static charge.

10. Operation

- a) Driving voltage should be kept within specified range; excess voltage shortens display life.
- b) Response time increases with decrease in temperature.
- c) Display may turn black or dark blue at temperatures above its operational range; this is (however not pressing on the viewing area) may cause the segments to appear "fractured".
- d) Mechanical disturbance during operation (such as pressing on the viewing area) may cause the segments to appear "fractured".

11. If any fluid leaks out of a damaged glass cell, wash off any human part that comes into contact with soap and water. The toxicity is extremely low but caution should be exercised at all the time.

12. Disassembling the LCD module can cause permanent damage and it should be strictly avoided.

13. LCD retains the display pattern when it is applied for long time (Image retention). To prevent image retention, do not apply the fixed pattern for a long time. Image retention is not a deterioration of LCD. It will be removed after display pattern is changed.

14. Do not use any materials, which emit gas from epoxy resin (hardener for amine) and silicone adhesive agent (dealcohol or deoxym) to prevent discoloration of polarizer due to gas.

15. Avoid the exposure of the module to the direct sunlight or strong ultraviolet light for a long time.

The brightness of LCD module may be affected by the routing of CCFL cables due to leakage to the chassis

through coupling effect. The inverter circuit needs to be designed taking the level of leakage current into

consideration. Thorough evaluation is needed for LCD module and inverter built into its host equipment to ensure specified brightness.