

Assembly Instructions for SCA6x0 and SCA10x0 series

TABLE OF CONTENTS

Table of Contents	1
1 Objective	2
2 VTI'S DIL-8 and DIL-12 packages	2
3 Package Outline and Dimensions	2
4 Tape and reel specifications	3
5 Printed Circuit Board (PCB) Level Guidelines	5
5.1 Recommended PCB pad layout	5
5.2 Solder paste and Cleaning process	5
5.3 Stencil	6
5.4 Paste printing	6
5.5 Component picking and placement	6
5.6 Reflow soldering	6
5.7 Moisture sensitivity level (MSL) classification	7
5.8 Inspection	8
6 Hand Soldering Guidelines	9
7 Rework Guidelines	10
7.1 Instructions for desoldering and removing of component	10
8 Environmental Aspects	11
9 References	11
10 Document Change Control	12

1 Objective

This document provides general guidelines for Printed Circuit Board (PCB) design and assembly of VTI's surface mountable DIL type of Pre-molded Lead-frame packages (DIL-8 for SCA6x0 series and DIL-12 for SCA10x0 series).

It should be emphasized that this document serves only as a design guideline to help develop the optimal assembly conditions. It is essential that users also use their own manufacturing practices and experience to be able to fulfill the needs of varying end-use applications.

2 VTI'S DIL-8 and DIL-12 packages

The SCA6x0 and SCA10x0 series products are SMD DIL-8 / DIL-12 components, pick-and-place mountable, and reflow solderable. These components are completely lead-free and designed to meet the demanding lead free soldering processes. The package consists of a pre-molded plastic housing, with a copper based lead frame having gull-wing type of leg pins on the side of the package to provide electrical contact to the PCB. A metal lid is attached to the top of the package. The DIL-8 and DIL-12 packages are presented in Figure 1.

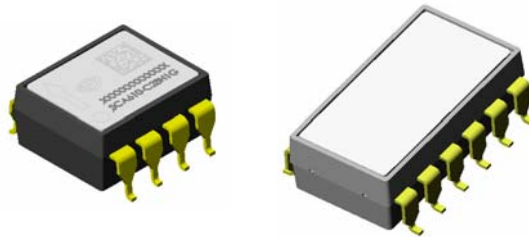

Figure 1: Three dimensional views of the DIL-8 and DIL-12 packages.

3 Package Outline and Dimensions

The outline and dimensions for the DIL-8 package are presented in Figure 2.

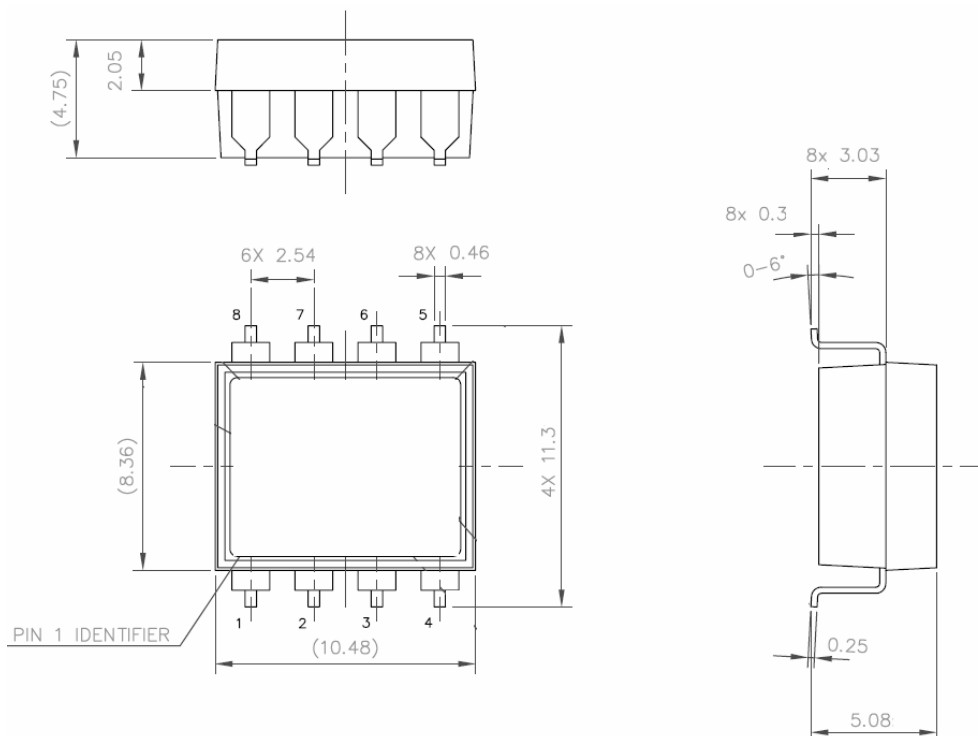

Figure 2: Outline and dimensions for DIL-8 package.

The outline and dimensions for the DIL-12 package are presented in Figure 3.

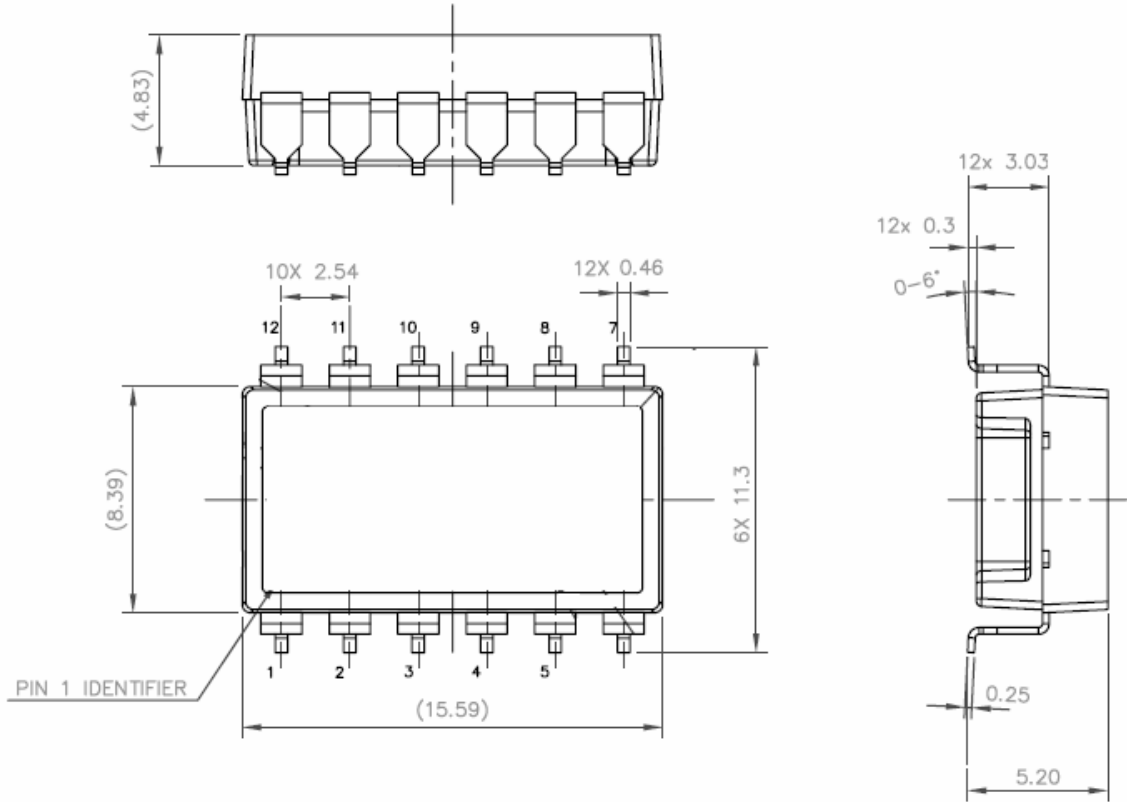

Figure 3: Outline and dimensions for DIL-12 package.

4 Tape and reel specifications

Packing tape dimensions are presented in figure 4. The unreeling direction and component polarity on tape are presented in figure 5. Reel dimensions are presented in figure 6.

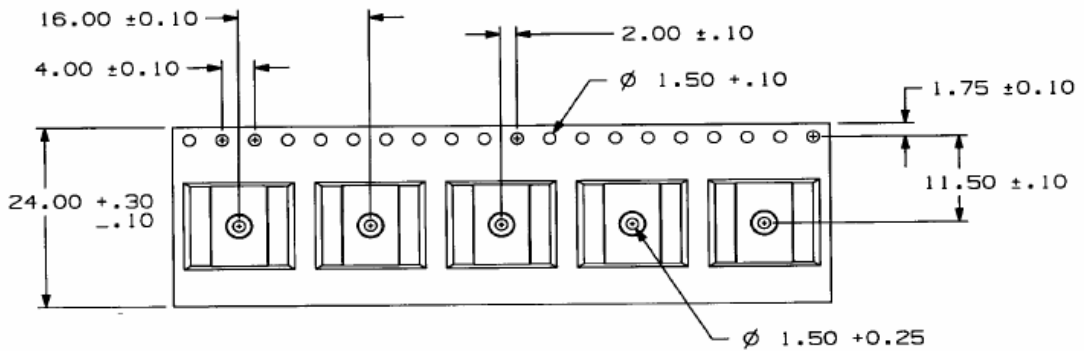

Figure 4: Packing tape dimensions for the DIL-8 and DIL-12 package. All dimensions in millimeters (mm).

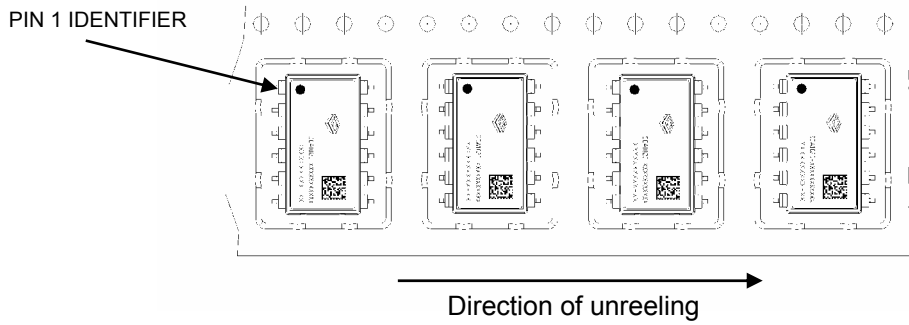
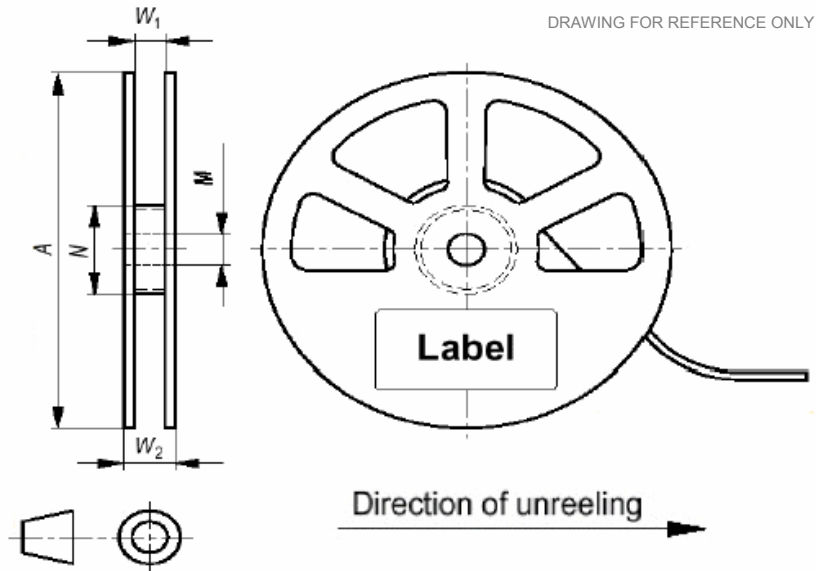

Figure 5: Package orientation on the tape and unreeling direction on tape.



<i>A</i>	<i>W</i>	<i>N_{min}</i>	<i>W₁</i>	<i>W_{2max}</i>	<i>M</i>
330	24	102	24.4 ± 2	30.4	∅13.0 ± 0.25

Figure 6: Reel dimensions. All dimensions in millimeters (mm).

5 Printed Circuit Board (PCB) Level Guidelines

5.1 Recommended PCB pad layout

For optimal soldering and solder joint reliability results of VTI's DIL component, the PCB terminal pads should be designed larger than the package leads. Reference dimensions for the land pad design are presented in Figure 7. Note that this is only an example and e.g. much narrower pads can be used and also the length can be different.

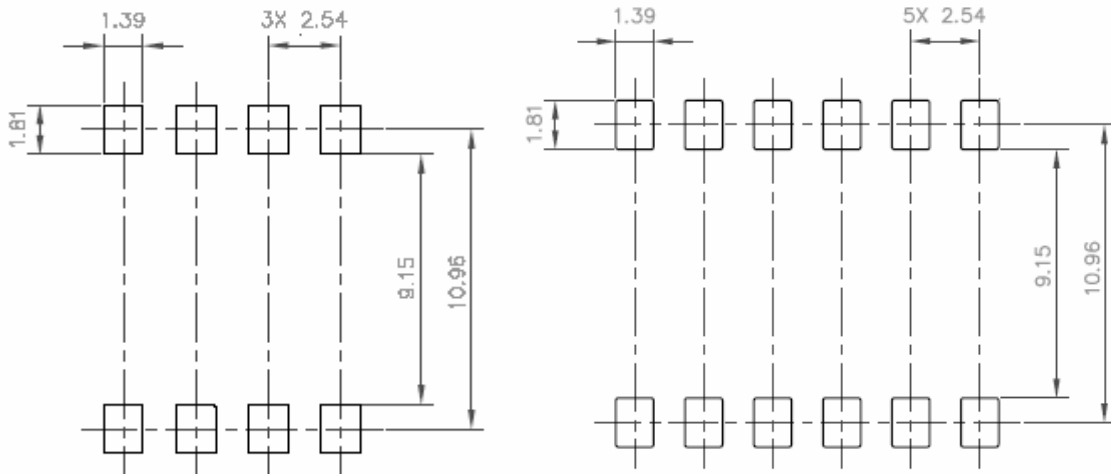

REFERENCE PCB LAYOUT FOR SCA6x0

REFERENCE PCB LAYOUT FOR SCA10x0

Figure 7: PCB pad lay-out for the DIL-8 and DIL-12.

VTI's DIL packages can be soldered on commonly used substrates, e.g. FR-4, ceramic etc. The pad metallization should be solder wettable in order to assure good quality solder joints. For fine pitch assembly, the quality of plating is important. Generally used circuit board finishes for fine pitch SMD soldering are NiAu, OSP, Electroless-Ag and Electroless-Sn.

5.2 Solder paste and Cleaning process

The DIL package can be soldered with lead-free SAC (tin-silver-copper) solder. The SAC solder paste composition should be near eutectic. The melting point of lead-free SAC solder can vary between 217–221°C, depending on the composition of solder alloy. In order to guarantee full RoHS compatibility lead-free solder should be used for the soldering of VTI's DIL component. Also traditional eutectic SnPb solder can be used for soldering the DIL packages if a lead-free process is not required. With the eutectic SnPb solder, the melting point is 183°C.

A no-clean solder paste should be used, since the cleaning process is not recommended. The metal lid on the pre-molded package is not fully sealed and there is a risk that cleaning fluids might penetrate inside the package. If cleaning is used, user must validate that the process does not decrease the performance or reliability of the component. **Ultrasonic agitation is strictly prohibited for VTI's MEMS components. Ultrasonic might destroy the MEMS structures.**

The solder paste which is used must be suitable for printing it through the stencil aperture dimensions. Type 3 paste is recommended (grain size 25-45µm).

5.3 Stencil

The solder paste is applied onto the PCB using stencil printing. The stencil thickness and aperture determines the precise volume of solder paste deposited onto the land pattern. Stencil alignment accuracy and consistent solder volume transferring are important parameters for achieving uniform reflow soldering results. Too much solder paste can cause bridging and too little solder paste can cause insufficient wetting or open solder joint. Generally the stencil thickness needs to be matched to the needs of all components on the PCB taking account the co-planarity spec of VTI's DIL components.

The co-planarity of VTI's DIL components is specified max 0.1mm (100µm). For the DIL-8 and DIL-12 packages, the recommended stencil thickness is 0,15mm (150µm). The minimum thickness is 0,125mm (125µm).

Stencil apertures in general can be 1:1 to PWB pad sizes, or stencil apertures can be reduced by 5-10% from all sides in regard to the PCB land pad size. This reduction of aperture size can reduce bridging between solder joints. Generally, reduction is recommended if PCB lands are plated with solder.

5.4 Paste printing

The paste printing speed should be adjusted according to the solder paste specifications. It is recommended that proper care of printing speed is taken during the paste printing in order to ensure correct paste amount, shape, position, and other printing characteristics. Neglecting any of these can cause open solder joints, bridging, solder balling, or other unwanted soldering results.

5.5 Component picking and placement

The DIL package can be picked from the carrier tape using either vacuum assist or mechanical type pick heads. Typically a vacuum nozzle is used. Pick up nozzles are available in various sizes and shapes to suit a variety of different component geometries. VTI's DIL packages are relatively large and heavy and on the other hand accelerometers require as accurate positioning as possible. For this reason, it is recommended that different pick up nozzles are tested to find the best one. The polarity of the part must be assured in taping process. The orientation of the part on tape is presented in Figure 5.

DIL packages must be placed onto the PCB accurately according to their geometry. The reference planes are the bottom and the side walls of the component. Placement should be done with modern automatic component pick & place machinery using vision systems. Recognition of the packages automatically by a vision system enables correct centering and orientation of packages. Pin #1 is indexed by a dot mark on the component lid as illustrated in figure 5.

In the case of double sided SMT assembly, it should be noted that VTI's components are relatively heavy and they should be glued on the PCB if they are located on the bottom side of the PCB during the second solder reflow process. VTI's does not recommend any specific glue for this purpose. Some of VTI's customers have used standard epoxy based SMD adhesives.

5.6 Reflow soldering

A forced convection reflow oven is recommended to be used for soldering DIL components. IR-based reflow ovens are not generally suitable for lead-free soldering. Figure 8 presents a general forced convection reflow solder profile and it also shows the typical phases of a reflow process.

The reflow profile used for soldering the DIL package should always follow the solder paste manufacturer's specifications and recommended profile. **If washing process is done after the soldering process, it must be noted that ultrasonic agitation wash after reflow is not allowed for VTI's DIL packaged MEMS components.** As mentioned before (section 5.2) a no-clean paste is recommended.

The typical ramp up rate is 3°C/second max. For lead-free soldering with SnAgCu solder the pre-heat temperature zone is ~ 150°-200° and should last for ~ 60-180 seconds. Time above the liquidus temperature (~217°C) should be ~ 60-150 seconds. The reflow peak max. temperature should not exceed 250°. Temperature within actual peak temperature is typically ~20-40 seconds. Ramp down rate should generally be 6°C/second max.

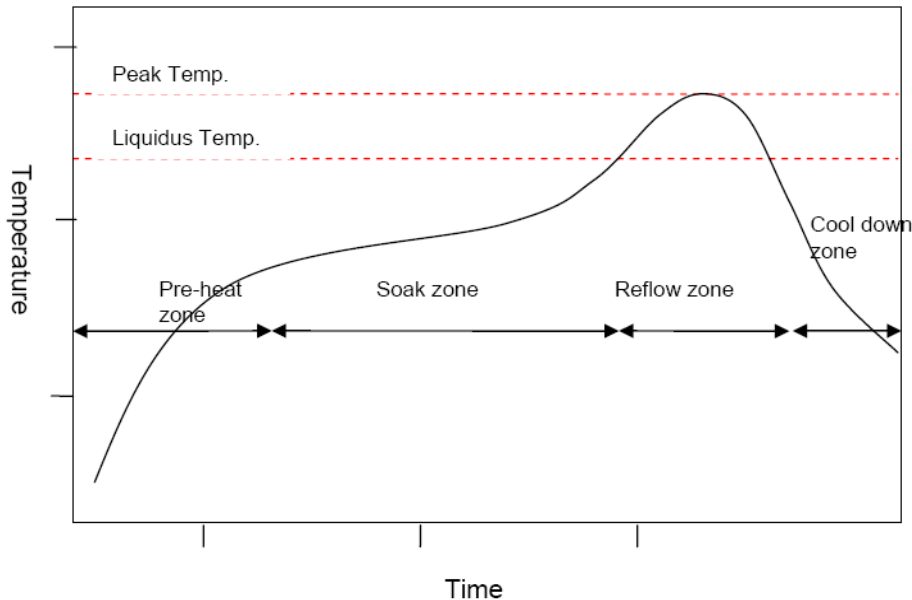

Figure 8: Typical convection reflow soldering phases and profile.

The process window for lead-free soldering is narrower than for traditional eutectic SnPb solders. Thus, caution has to be taken care when adjusting the reflow profiles. The reflow profile should be measured using a thermo-couple measurement system. It is recommended to use at least three thermo-couples, depending on the application. As a general guide, one thermo-couple should be placed under a component having the largest thermal mass, one next to the smallest component, one should be in contact with DIL component's solder joint, and others to the appropriate spots on a circuit board, e.g. corner, center, bottom of the board etc. The reflow profile should be adjusted according to the measured data so that each solder joint experiences an optimal reflow profile. The temperature gradient should be as small as possible across the circuit board. Extreme caution has to be taken if the circuit board contains components with highly different thermal masses.

5.7 Moisture sensitivity level (MSL) classification

The Moisture Sensitivity Level of the DIL component is Level 3 according to the IPC/JEDEC J-STD-020C. This means that the part is delivered in a dry pack bag and the manufacturing floor time (out of bag) at the customer's end is 168 hours.

Following instruction shall be followed:

1. Calculated shelf life in sealed bag: 12 months at < 40 °C and < 90% relative humidity (RH).
2. Maximum soldering peak temperature for the package is 250°C/40sec, measured from the package body.
3. After bag is opened, devices that will be subjected to reflow solder or other high temperature process must be
 - a) Stored at <10% RH,
 - or
 - b) Mounted within 168 hours of factor conditions ≤30 °C/60%RH.

Note: Do not re-store devices that have exposed >10% RH conditions.

4. Devices require bake, before mounting, if:
 - a) Humidity Indicator Card is $> 10\%$ when read at $23 \pm 5 \text{ }^\circ\text{C}$
 - b) 3a or 3b not met.
5. If baking is required, devices may be baked for 24 hours at 85°C .
Note: Also Tape&Reel materials are applicable for baking at 85°C

Note: Packing materials and procedures according to IPC/JEDEC J-STD-033

Note: Level and body temperature defined by IPC/JEDEC J-STD-020

5.8 Inspection

Optical and visual inspection of solder joints can be done easily, since the solder joints are clearly seen. A visual inspection of the solder joints with conventional AOI (automatic optical inspection) system can be used. Also X-ray inspection can be used.

Cross-sectional analysis is also an approved method to inspect how well solder has wetted the pads of component. Cross-sectional analysis is not used for production inspection, but if required, it can be used to establish and optimize the component assembly process parameters. Cross-sectioning is a destructive inspection method. An example of a DIL solder joint cross-section in presented in Figure 9.

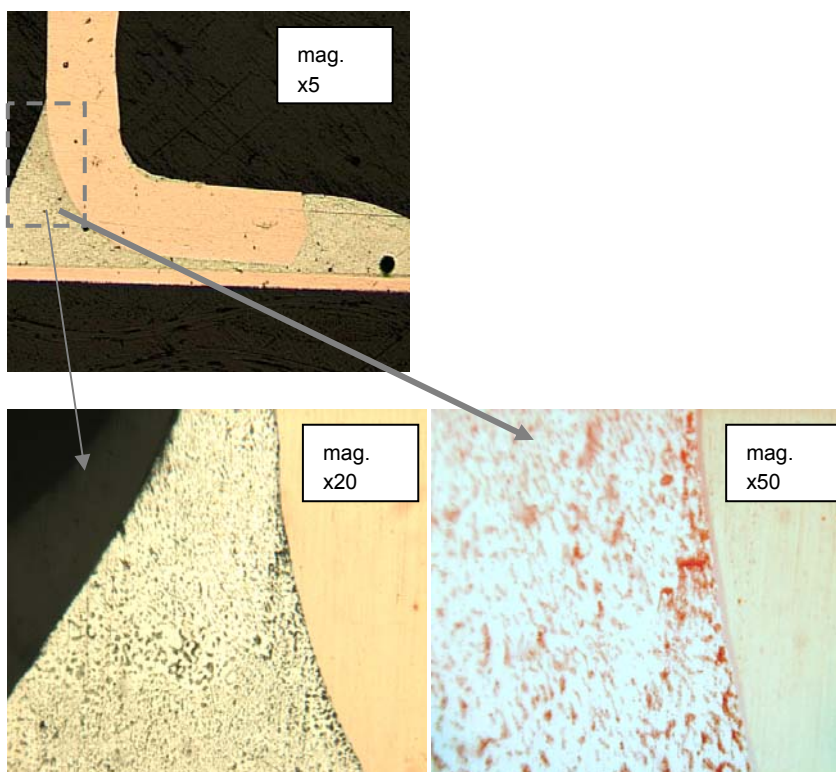

Figure 9: Cross-section of the DIL package lead's solder joint (with eutectic SnPb solder).

6 Hand Soldering Guidelines

For hand soldering of the DIL component, VTI recommends eutectic tin-lead solder due to the lower melting point compared to lead-free solders. Key thing is that as soon as the solder flows the soldering iron must be removed from the board. The package temperature should be kept under 280°C (max 250°C recommended) and all mechanical stresses in the pin should be minimized. It should be noted, that also PCB material might damage if too much heat or force is used.

Generally the hand soldering of the DIL component can be done in two different ways:

Method A: Soldering of components with tin wire and soldering iron

Method B: Soldering by applying solder paste onto PCB land pads and *then* using reflow heating or soldering iron to melt the paste and achieve the soldered joint.

METHOD A: Soldering of components with soldering iron

Use the tin wire and soldering iron to solder the component onto PCB. Do not touch the package plastic body with the soldering iron, soldering iron should touch only the PCB pad and through that the heat should be conducted to the tin wire and component lead. VTI has used 315°C setting temperature for component soldering. The temperature on the tip of the tool is 270...275°C. Soldering process takes only few seconds for each pin. For leaded soldering we have used Multicore Sn60Pb40 and for lead-free soldering Almit KR-19SHrma flux-cored solder wire.

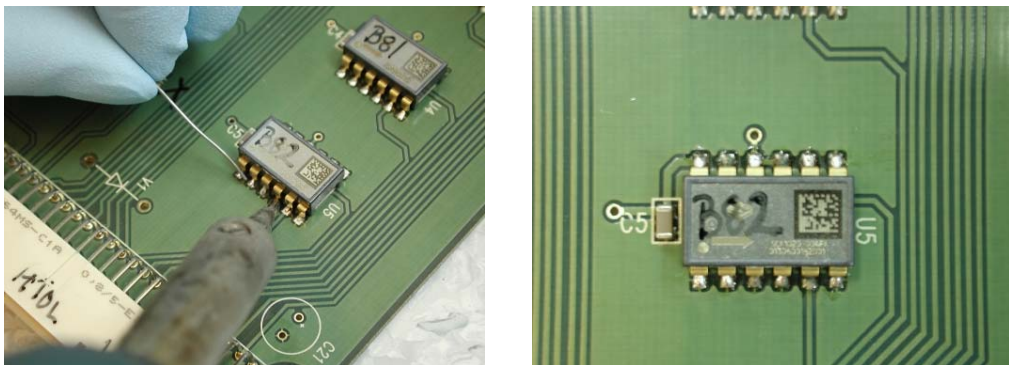

Figure 10: Using tin wire and soldering iron for hand soldering.

METHOD B: Soldering by applying solder paste and then using reflow heating or soldering iron

1. Apply the solder paste onto the PCB land pads. The paste can be applied by two different methods.
 - Manual solder paste printing through a stencil with normal openings designed for the DIL component.
 - Needle dispensing of solder paste manually onto the PCB pads. VTI recommends use of a microscope in manual solder paste dispensing. Dispensing needle tip size can be 0.12"-0.16".
2. Place the component gently on top of the solder paste. To avoid solder bridging, push only very gently on top of the component.

Melt the solder paste by putting the part through reflow oven *or* by using soldering iron as mentioned in the previous part.

7 Rework Guidelines

If it becomes necessary to rework a SCA6x0/SCA10x0 series component, the preferred way to remove the component is by hot air. Use of a hot air rework station with a vacuum chuck, is the preferred method. A key issue in using hot-air is preventing thermal damage to the component or adjacent components.

If hot air rework station is not available, rework with thermal tweezers is also an acceptable alternative. This method is used at VTI e.g. for failure analysis purposes. This technical note describes VTI's rework procedure.

Removing of the component with hot iron only is difficult as it is easy to get the part too hot and destroy it. It is not recommend method if failure analysis or re-use of the component is desired.



7.1 Instructions for desoldering and removing of component

Soldering Station (Pace SensaTemp ST25E-PS90) and thermal tweezers (Pace Thermotweez) with Pace 1121-0416-P1 tool head are used for de-soldering and removing of the component.



Figure 11. Thermal tweezers, Pace Thermotweez **Figure 12:** Tool head, Pace 1121-0416-P1

The plastic molding compound on the component is LCP (liquid crystal polymer) which withstands very high temperatures and is good material for Pb-free assembly. LCP's melting point is 335°C. However, the mechanical properties start to change already near 280°C. If the pins are heated too long the plastic around pin will be softened and if there at the same time is some stress on the pin there is a risk that pin might move and cause increased reliability or wirebond break inside housing.

In order to melt all pins simultaneously, tweezers are recommended for de-soldering of the component. Also with tweezers, special care must be taken if failure analysis or re-use of the component is desired.

In the component removal process, the temperature setting in soldering station is normally +315°C. The temperature on the tip of the tool is 270...275°C. Tool is pressed against pins only for few seconds. Same temperature is used both for Pb-free and SnPb-solder joints, even though SnPb solders melt already below 200°C. Some temperature adjustment might be needed. Especially if tool head is old and 'dirty' temperature needs to be increased.

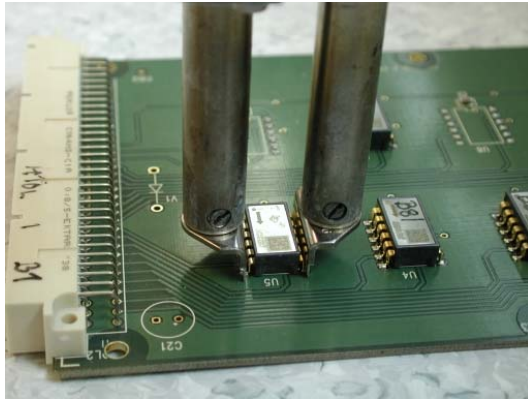

Figure 13. Tool head is carefully pressed around component and kept in this position for few seconds.

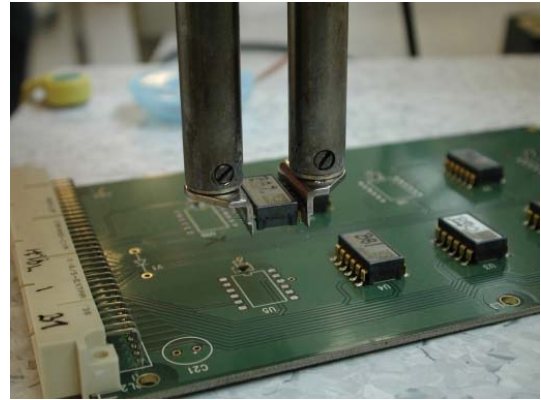

Figure 14. Immediately after solder melting, component is lifted.

Remove the solder from the PCB using either a solder vacuum or solder braid making sure to clean the area of solder thoroughly.

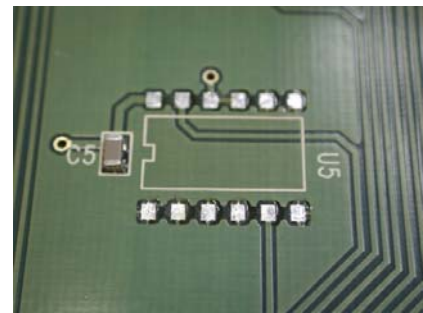
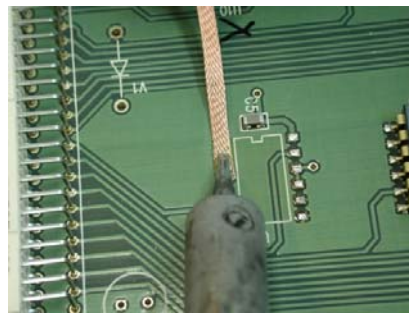
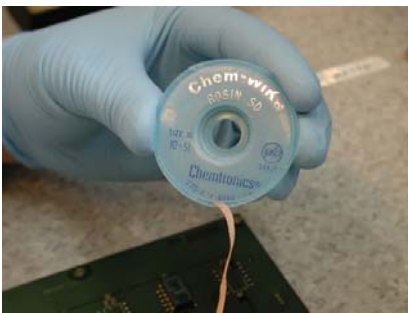

Figure 15. Soldering iron and solder braid used for solder removal.

Note that the performance and the reliability of the reworked component may have decreased due to the rework operation! VTI does not recommend rework.

8 Environmental Aspects

VTI Technologies respects environmental values and thus, its DIL packages are lead-free and RoHS compatible. VTI Technologies' sensors should be soldered with lead-free solders in order to guarantee full RoHS compatibility.

9 References

JEDEC / Electronic Industries Alliance, Inc. Moisture/ReflowSensitivity Classification for Non-Hermetic Solid State Surface Mount Devices (J-STD-020C).

Handling, Packing, Shipping and Use of Moisture/Reflow Sensitive Surface Mount Devices (IPC/JEDEC J-STD-033).

10 Document Change Control

Version	Date	Change Description
1.0	22.04.2008	Release

VTI Technologies reserves all rights to modify this document without prior notice.