

MATERIALS

BODY	BRASS NICKEL PLATED
CONTACT	GOLD PLATED
INSULATOR	PTFE

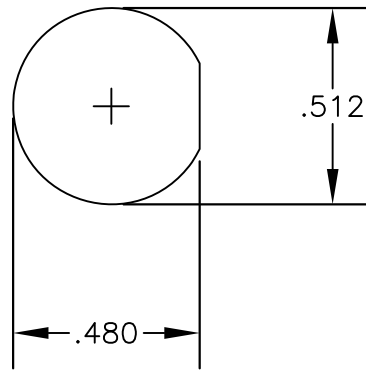

MOUNTING HOLE

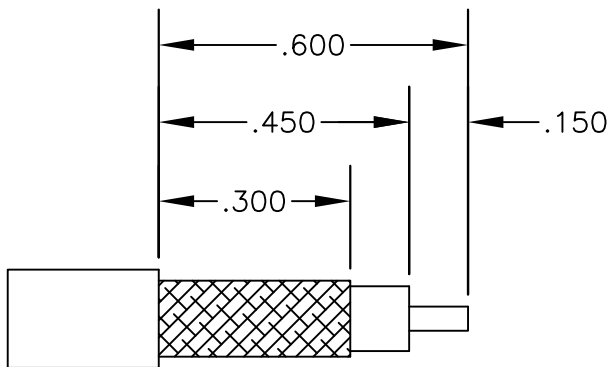
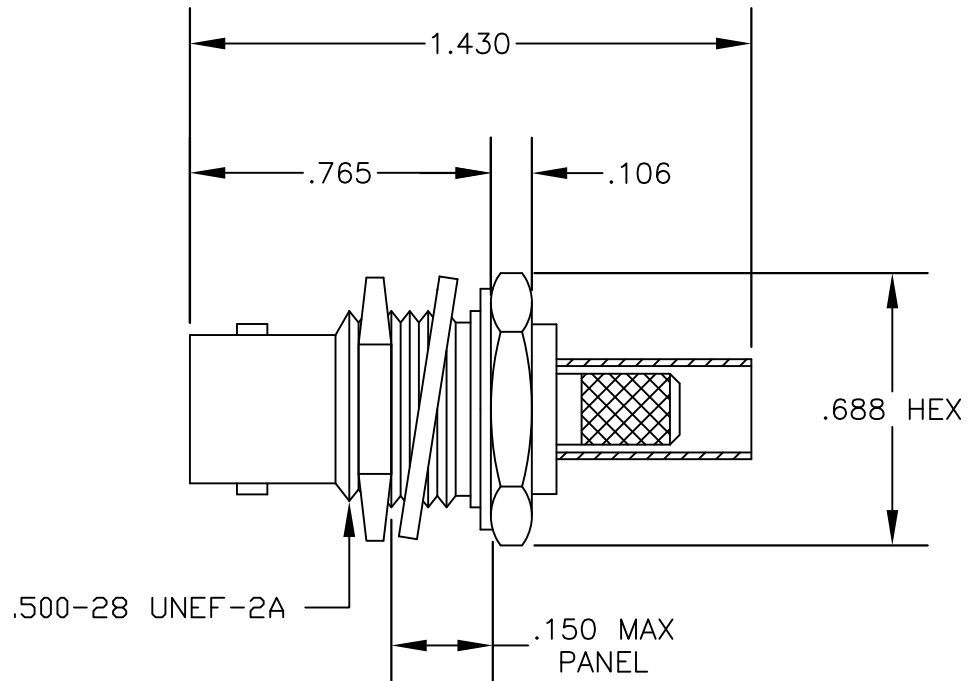

STRIPPING DIMENSIONS

CRIMP SIZES REQUIRED

CONTACT: .068" HEX CRIMP TOOL
 FERRULE: .213" HEX CRIMP TOOL



PASTERNACK ENTERPRISES, INC.

P.O BOX 16759, IRVINE, CA 92623
 PHONE (949) 261-1920 FAX (949) 261-7451

WEB ADDRESS: www.pasternack.com
 E-MAIL ADDRESS: sales@pasternack.com

COAXIAL & FIBER OPTICS

DWG TITLE

PE4208

DES.

BNC FEMALE, BULKHEAD CRIMP
 ATTACHMENT FOR RG58

REV. A

FSCM NO. 53919

CAD FILE 042210

SCALE N/A

SIZE A

147

NOTES:

1. UNLESS OTHERWISE SPECIFIED ALL DIMENSIONS ARE NOMINAL.
2. ALL SPECIFICATIONS ARE SUBJECT TO CHANGE WITHOUT NOTICE AT ANY TIME.
3. DIMENSIONS ARE IN INCHES.