

3 mm Square SMT Trimmer Potentiometers with the rotation stopper (Cermet, Open Frame Type)



Type: **EVM3V**

■ Features

- Rotation stopper featured type
- Automatic adjustment type
- High reliability realized by cermet element
- Excellent mountability
- Conforms to JIS C5260-1:1999
- RoHS compliant

■ Recommended Applications

- Audio/visual, office, and communication equipment
- General electronic equipment

■ Explanation of Part Numbers

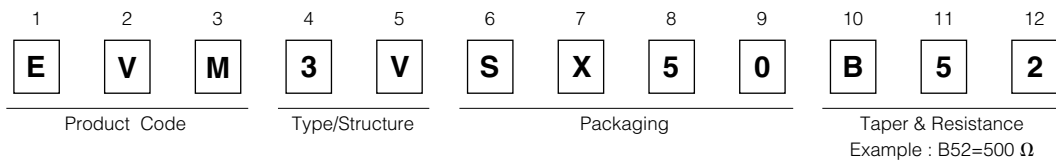

■ Specifications

Total Resistance Value	100 Ω to 1 MΩ
Resistance Tolerance	±25 %
Power Rating	0.15 W
Limiting Element Voltage	50 V
Rotation Torque	2 to 10 mN·m
Stopper Strength	15 mN·m min.
Temperature Coefficient of Resistance	±250 × 10 ⁻⁶ /°C

■ Minimum Quantity/Packing Unit

Part Number	Taping		
	Quantity per reel	Packaging quantity	Dia. of reel (mm)
EVM3V	2000	10000	φ178

The standard packaging methods for a reel is φ178.

Please contact us, if you would like different packaging methods. (Bulk, Reel of φ330, Reel of φ380)

■ Dimensions in mm (not to scale)

- 3-terminal, for Automatic Trimming Adjustment

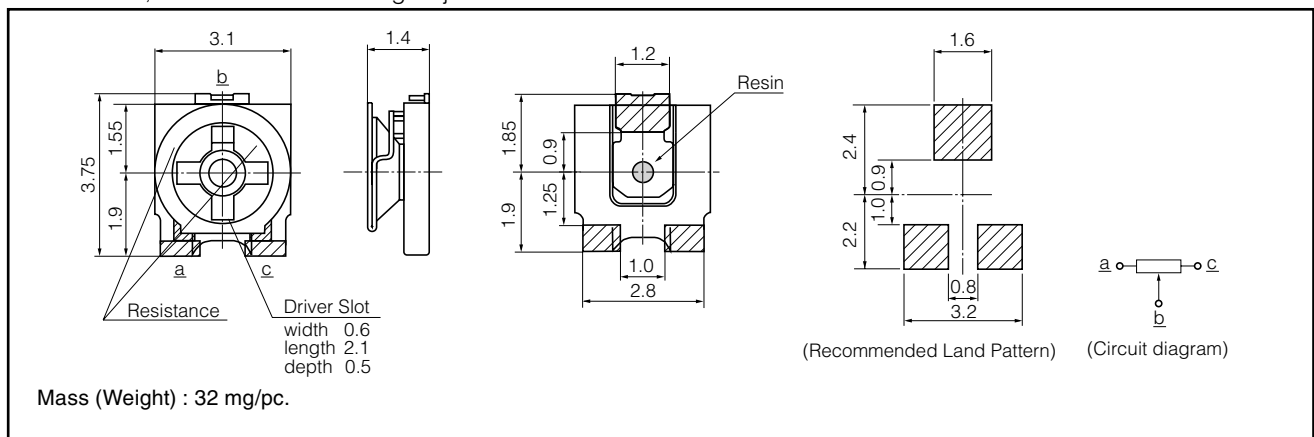

Design and specifications are each subject to change without notice. Ask factory for the current technical specifications before purchase and/or use.
Should a safety concern arise regarding this product, please be sure to contact us immediately.