

SS360PT/SS460P

High Sensitivity Latching Digital Hall-Effect Sensor ICs with Built-in Pull-up Resistor

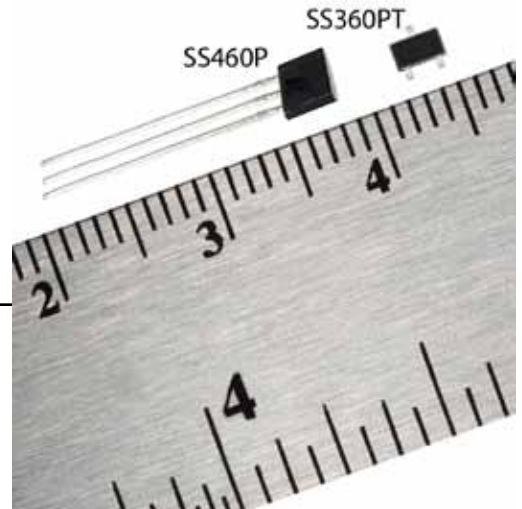

DESCRIPTION

The SS360PT/SS460P High Sensitivity Latching Hall-Effect Sensor ICs with Built-in Pull-up Resistor are small, sensitive and versatile devices that are operated by the magnetic field from a permanent magnet or an electromagnet. They are designed to respond to alternating North and South poles. The SS360PT is activated by a North pole while the SS460P is activated by a South pole.

The SS360PT/SS460P offers reliable switching points with a high magnetic sensitivity of 30 G typical (55 G maximum). This sensor IC does not use chopper stabilization on the Hall element, providing a clean output signal and a faster latch response time when compared to competitive high sensitivity Hall-effect bipolar latching sensor ICs which do use chopper stabilization.

The internal pull-up resistor often eliminates the need for external components, helping to reduce the system cost. These high-performance yet economical sensor ICs are well suited for demanding, cost-sensitive high-volume applications.

FEATURES AND BENEFITS

- **Fastest response time in its class:** Provides more efficiency in commutating a brushless dc motor
- **No chopper stabilization:** Results in a clean output signal
- **High sensitivity:** Operates from only 30 Gauss typical, at 25 °C [77 °F] and 55 Gauss maximum over the full -40 °C to 125 °C [-40 °F to 257 °F] temperature range, allowing for the use of smaller, magnets or a wider air gap
- **Internal pull-up Hall IC design:** Simplifies installation and helps reduce component count and system cost
- **Bipolar latching magnetics:** Makes these products well-suited for accurate speed sensing and RPM (revolutions per minute) measurement
- **Sub-miniature, SOT-23 surface mount package (SS360PT) supplied on tape and reel:** Allows for compact design with automated component placement
- **Small, leaded, flat TO-92-style package (SS460P):** Allows for a compact PC board layout
- **Wide operating voltage range of 3 Vdc to 24 Vdc:** Allows for potential use in a wide range of applications
- **Built-in reverse voltage capability:** Enhances the protection of the sensor and the circuits
- **Robust design:** Allows operation up to 125 °C [257 °F]
- RoHS-compliant material meets directive 2002/95

These products offer reverse polarity protection, deliver a stable output over a -40 °C to 125 °C [-40 °F to 257 °F] temperature range, and can accept a dc supply voltage from 3 Vdc up to 24 Vdc (see specifications below for details).

For brushless dc motor manufacturers that need latching sensors with reliable, consistent performance for more efficient and smaller designs, Honeywell's new family of High Sensitivity Hall-Effect Latching Sensor ICs with Built-in Pull-up resistor responds to low magnetic fields and offers repeatable operation while delivering faster response times to a change in magnetic field for better motor efficiency.

These Hall-effect devices are available in two package styles: the SS360PT in the miniature SOT-23 surface mount package and the SS460P in the leaded, flat TO-92-style package.

The SS360PT is supplied on tape and reel (3000 units per reel). The SS460P is available in a bulk package (1000 units per bag).

SS360PT/SS460P

POTENTIAL APPLICATIONS

Industrial/Commercial

- Brushless dc motor commutation for white goods and other appliances
- Flow-rate sensing
- Speed and RPM sensing
- Tachometer, counter pickup
- Motor and fan control

Table 1. SS360PT/SS460P Performance Specifications (At 3 Vdc to 24 Vdc supply, 20 mA load, $T_A = -40\text{ °C}$ to 125 °C [-40 °F to 257 °F] except where otherwise specified.)

Characteristic	Condition	Min.	Typ.	Max.	Unit
Supply voltage:					
SS360PT	-40 °C to 110 °C [-40 °F to 230 °F]	3	–	24	Vdc
SS360PT	125 °C [257 °F]	3	–	16	
SS460P	-40 °C to 125 °C [-40 °F to 257 °F]	3	–	24	
Supply current	$V_{\text{supply}} = 3\text{ V}$ at 25 °C [77 °F]	–	3.5	6	mA
	–	–	–	10	
Vsat	Gauss >55	–	–	0.6	V
Output leakage current	Gauss >55	–	–	10	μA
Internal pull-up resistor	–	7.5	10.0	12.5	kOhm
Rise/fall time	$V_{\text{supply}} = 12\text{ V}$ at 25 °C [77 °F]	–	–	1.5	μs
Thermal resistance:					
SS360PT (SOT-23)	–	–	303	–	°C/W
SS460P (flat TO-92-style)	–	–	233	–	
Operate	-40 °C to 125 °C [-40 °F to 257 °F]	5	30	55	Gauss
Release	-40 °C to 125 °C [-40 °F to 257 °F]	-55	-30	-5	Gauss
Differential	-40 °C to 125 °C [-40 °F to 257 °F]	40	60	80	Gauss
Operating temperature	$V_{\text{supply}} = 3\text{ Vdc}$ to 24 Vdc	-40 [-40]	–	125 [257]	°C [°F]
Storage temperature:					
SS360PT	–	-40 [-40]	–	150 [302]	°C [°F]
SS460P	–	-40 [-40]	–	165 [329]	

NOTICE

Bipolar Hall-effect sensor ICs may have an initial output in either the ON or OFF state if powered up with an applied magnetic field in the differential zone (applied magnetic field $>B_{rp}$ and $<B_{op}$). Honeywell recommends allowing $10\ \mu\text{s}$ for output voltage to stabilize after supply voltage has reached its normal operating value.

NOTICE

The magnetic field strength (Gauss) required to cause the switch to change state (operate and release) will be as specified in the magnetic characteristics. To test the switch against the specified magnetic characteristics, the switch must be placed in a uniform magnetic field.



Table 2. SS360PT/SS460P Absolute Maximum Ratings¹

Characteristic	Min.	Typ.	Max.	Unit
Supply voltage	-26.0	–	26.0	V
Applied output voltage	-0.5	–	26.0	V
Output current	–	–	20	mA
Magnetic flux	–	–	no limit	Gauss

Note 1: Absolute maximum ratings are the extreme limits that the device will withstand without damage to the device. However, the electrical and mechanical characteristics are not guaranteed as the maximum limits (above recommended operating conditions) are approached, nor will the device necessarily operate at absolute maximum ratings.

High Sensitivity Latching Hall-Effect Sensor ICs with Built-in Pull-up Resistor

Figure 1. Sensor IC Block Diagram

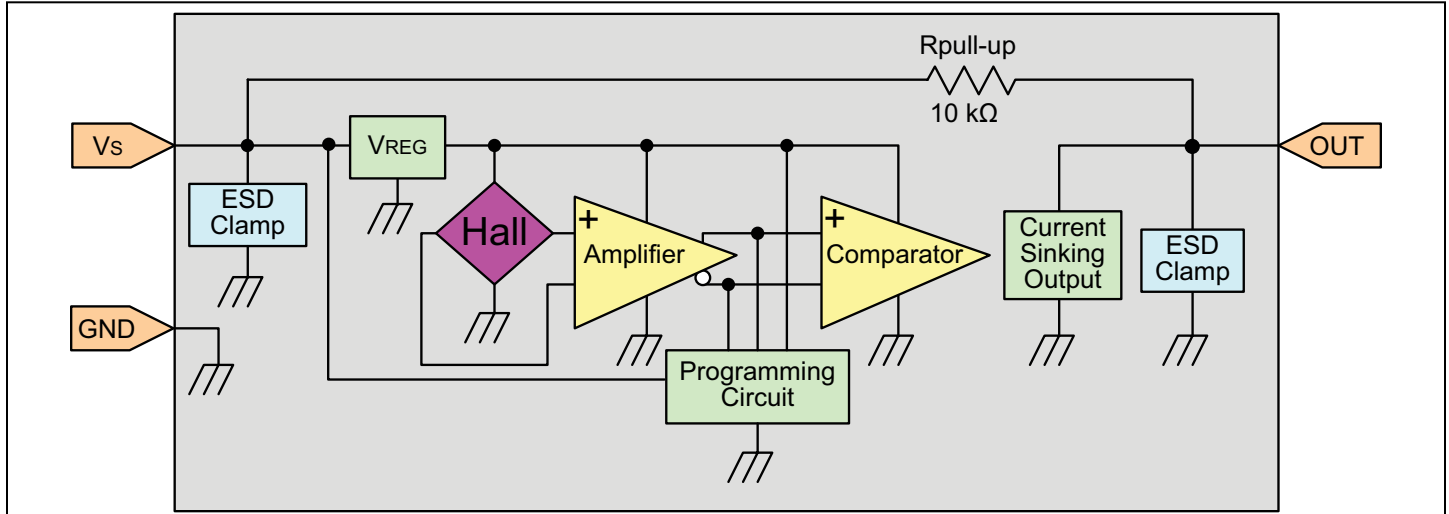

Figure 2. Typical Magnetic Characteristics vs Ambient Temperature at Supply Voltages

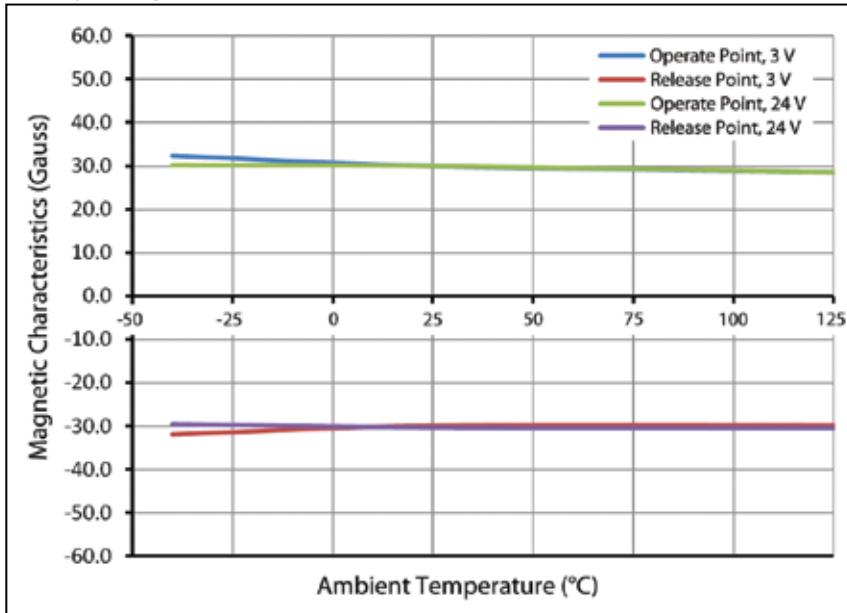

Figure 3. SS360PT Maximum Rated Supply Voltage vs Temperature

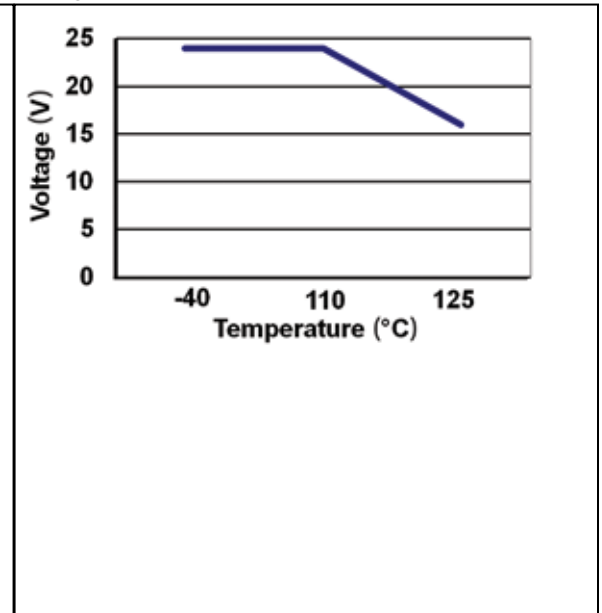
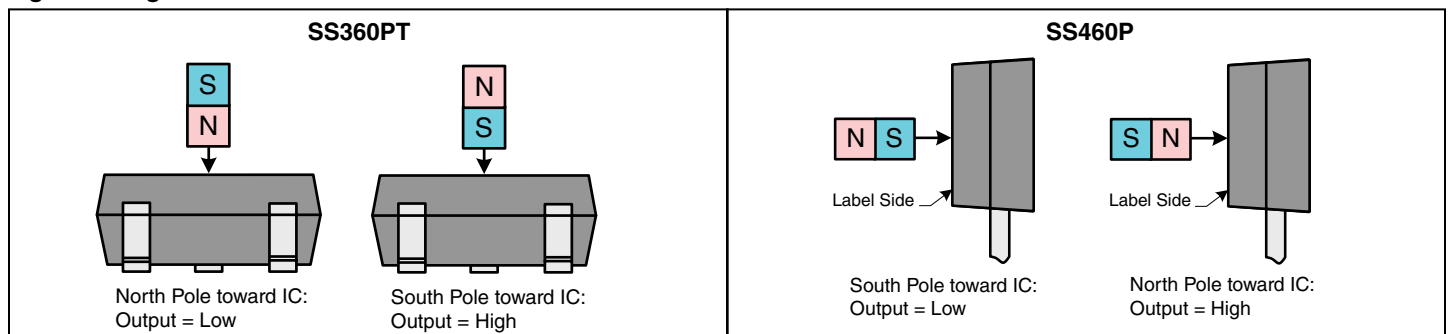

Figure 4. Magnetic Activation



SS360PT/SS460P

Figure 5. SS360PT Mounting and Tape/Reel Dimensions (For reference only. mm/[in].)

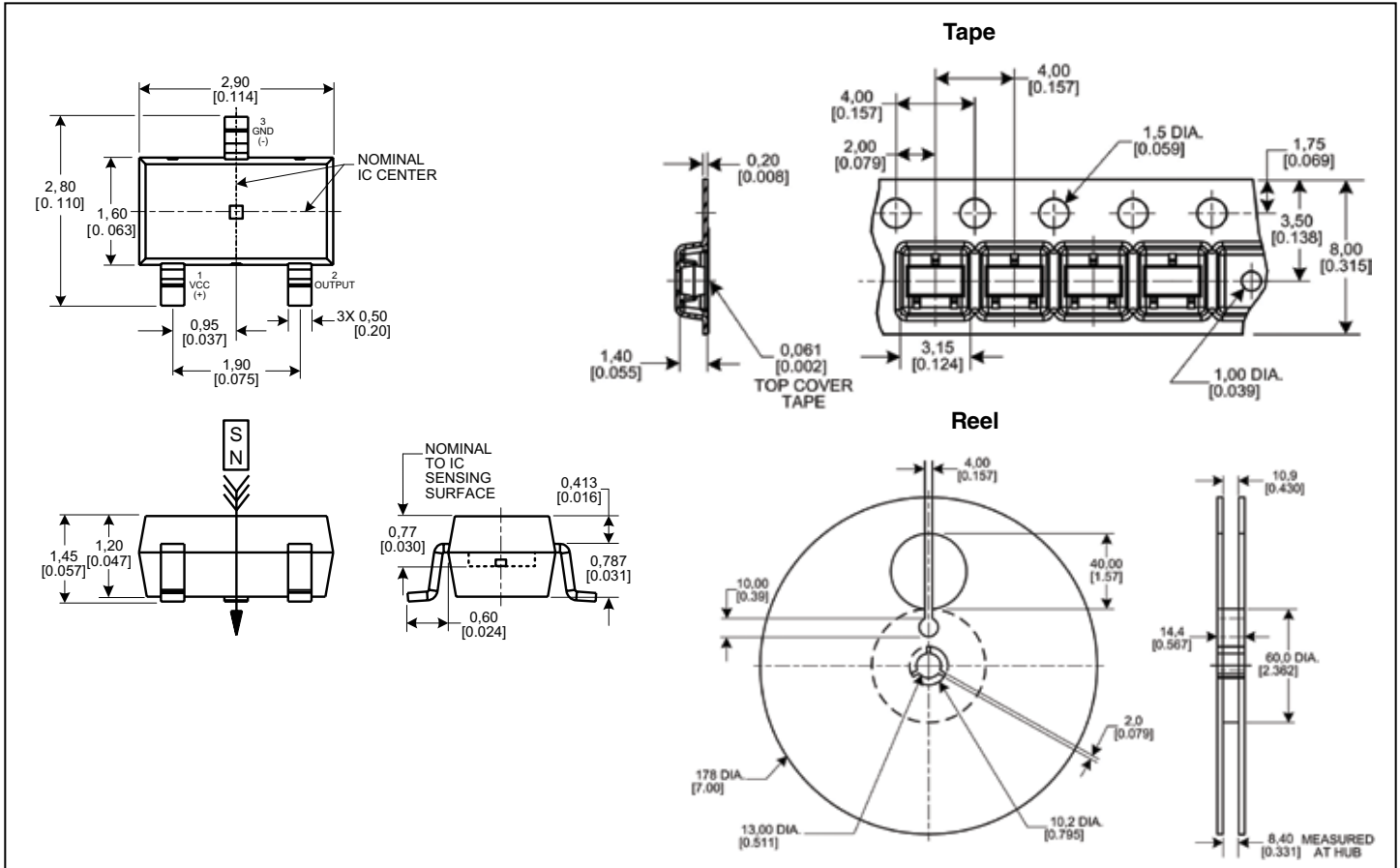
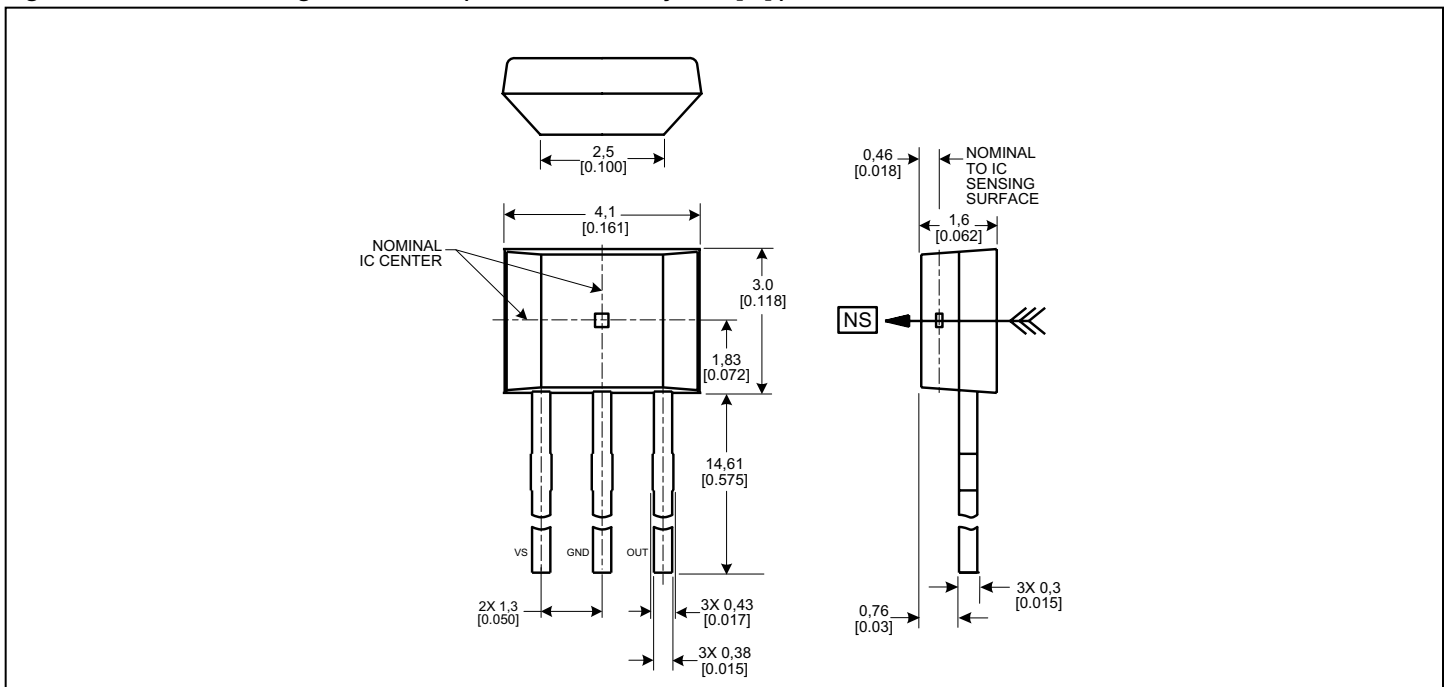

Figure 6. SS460P Mounting Dimensions (For reference only. mm/[in].)



Order Guide

Catalog Listing	Description
SS360PT	High sensitivity latching, digital Hall-effect sensor IC with built-in pull-up resistor, North pole activated, SOT-23 package, tape and reel packaging (3000 units per reel)
SS460P	High sensitivity latching, digital Hall-effect sensor IC with built-in pull-up resistor, South pole activated, flat TO-92-style package, bulk packaging (1000 units per bag)

WARNING

PERSONAL INJURY

DO NOT USE these products as safety or emergency stop devices or in any other application where failure of the product could result in personal injury.

Failure to comply with these instructions could result in death or serious injury.

WARRANTY

Honeywell warrants goods of its manufacture as being free of defective materials and faulty workmanship. Honeywell's standard product warranty applies unless agreed to otherwise by Honeywell in writing; please refer to your order acknowledgement or consult your local sales office for specific warranty details. If warranted goods are returned to Honeywell during the period of coverage, Honeywell will repair or replace, at its option, without charge those items it finds defective. **The foregoing is buyer's sole remedy and is in lieu of all warranties, expressed or implied, including those of merchantability and fitness for a particular purpose. In no event shall Honeywell be liable for consequential, special, or indirect damages.**

While we provide application assistance personally, through our literature and the Honeywell web site, it is up to the customer to determine the suitability of the product in the application.

Specifications may change without notice. The information we supply is believed to be accurate and reliable as of this printing. However, we assume no responsibility for its use.

WARNING

MISUSE OF DOCUMENTATION

- The information presented in this datasheet is for reference only. DO NOT USE this document as product installation information.
- Complete installation, operation and maintenance information is provided in the instructions supplied with each product.

Failure to comply with these instructions could result in death or serious injury.

SALES AND SERVICE

Honeywell serves its customers through a worldwide network of sales offices, representatives and distributors. For application assistance, current specifications, pricing or name of the nearest Authorized Distributor, contact your local sales office or:

E-mail: info.sc@honeywell.com

Internet: sensing.honeywell.com

Phone and Fax:

Asia Pacific +65 6355-2828

+65 6445-3033 Fax

Europe +44 (0) 1698 481481

+44 (0) 1698 481676 Fax

Latin America +1-305-805-8188

+1-305-883-8257 Fax

USA/Canada +1-800-537-6945

+1-815-235-6847

+1-815-235-6545 Fax

Sensing and Control
Honeywell
1985 Douglas Drive North
Golden Valley, MN 55422 USA
sensing.honeywell.com

009560-1-EN
September 2013
Copyright © 2013 Honeywell International Inc. All rights reserved.

Honeywell