

PART NUMBER: GC0351M
DESCRIPTION: SPEAKER

SPECIFICATIONS

parameter	conditions/description	min	nom	max	units
nominal size	16 x 35 mm				
impedance	at 1.5 kHz, 1 V	6.8	8	9.2	Ω
resonant frequency	at 1 V	520	650	780	Hz
sound pressure level	1 W, 50 cm ave., at 0.8, 1, 1.2, 1.5k Hz	78	81	84	dB
response	10 dB max.	Fo		20,000	Hz
input power			1	1.5	W
operation	must be normal at program source		1		W
buzz, rattle, etc.	must be normal at sine wave		2.83		V dc
magnet	size: 7.9 x 1.3 mm				
load test	24 hours of white noise at		1		W
heat test	20 ~ 50% RH for 24 hours	58	60	62	$^{\circ}$ C
humidity test	90 ~ 95% RH for 24 hours	38	40	42	$^{\circ}$ C
RoHS	yes				

FREQUENCY RESPONSE CURVE

parameter	conditions/description
potentiometer range	50 dB
rectifier	RMS
lower limit frequency	20 Hz
wr. speed	100 mm/sec
zero level	60 dB

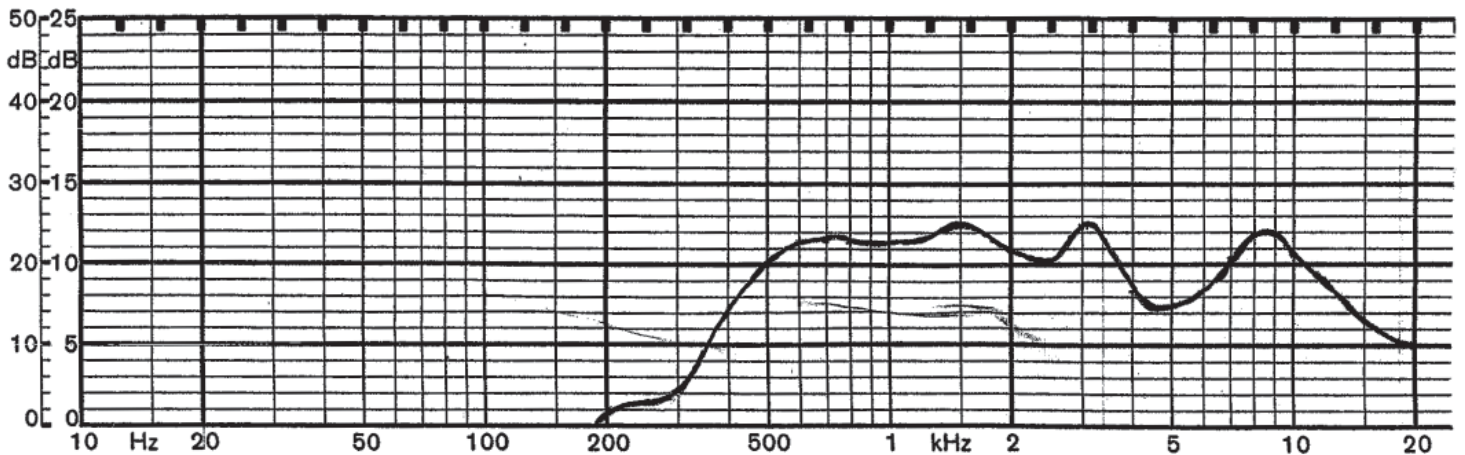

REV.	DESCRIPTION	DATE
A	NEW DRAWING	6/4/2007

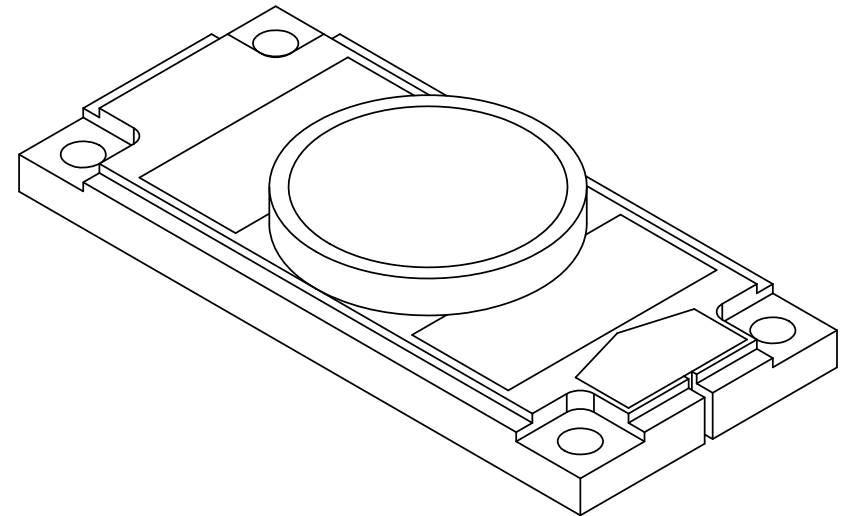
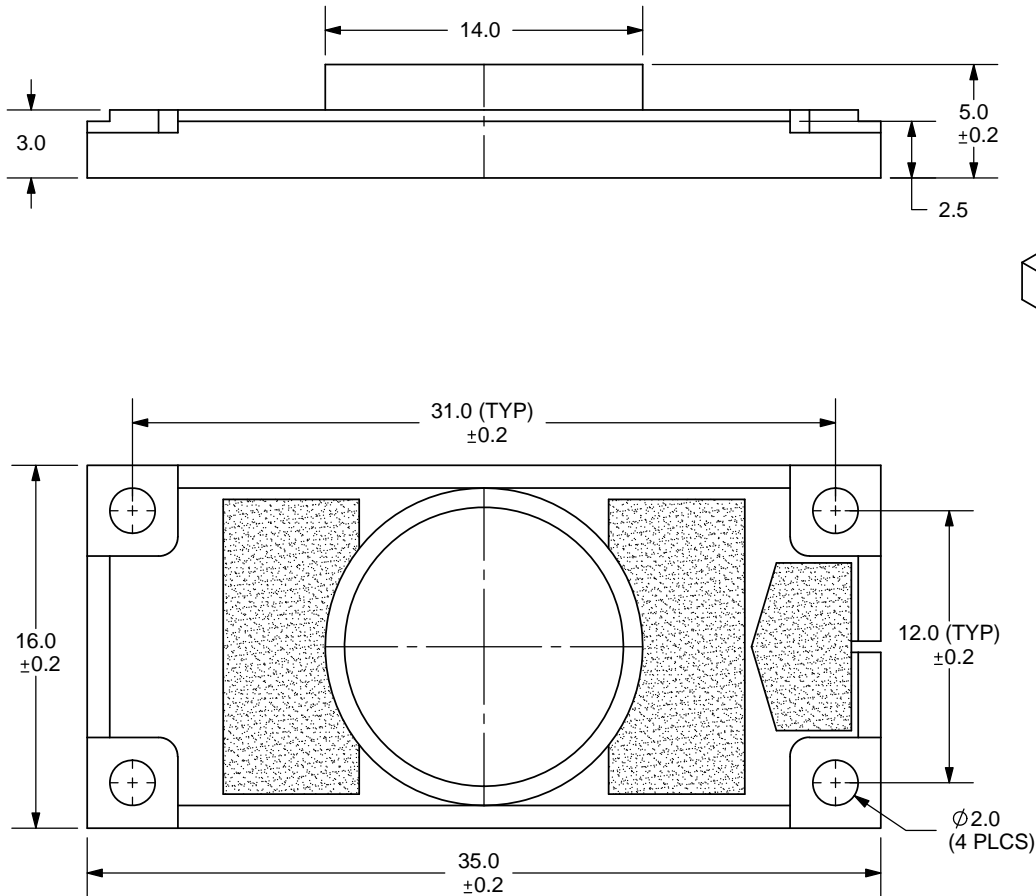

TOLERANCE:
±0.5mm UNLESS OTHERWISE
SPECIFIED



20050 SW 112th Ave.
Tualatin, OR 97062
Phone: 503-612-2300
800-275-4899
Fax: 503-612-2383
Website: www.cui.com

TITLE: LOW PROFILE NOTEBOOK SPEAKER		REV: A
PART NO. GC0351M	UNITS: MM [INCHES]	
DRAWN BY: ZRJ	APPROVED BY:	SCALE: 3:1

PC FILE NAME:
GC0351M

COPYRIGHT 2007 BY CUI INC.