

2.5V to 12V Output MD1322F

DESCRIPTION

The MD1322F is a high-efficiency step down DC-DC converter power integrated circuit with main MOSFET switch and Schottky Barrier Diode. The MD1322F can deliver 7.5 watts maximum (5V, 3.0A) with high efficiency over a wide input voltage range. This device has output voltage digitally selectable from 2.5V to 12V. With the MD1322F you can construct a complete DC-DC converter using only a few external components. Featuring an HSOP 28-pin surface mount package, the MD1322F allows you to incorporate a very small and thin power supply on your circuit board.

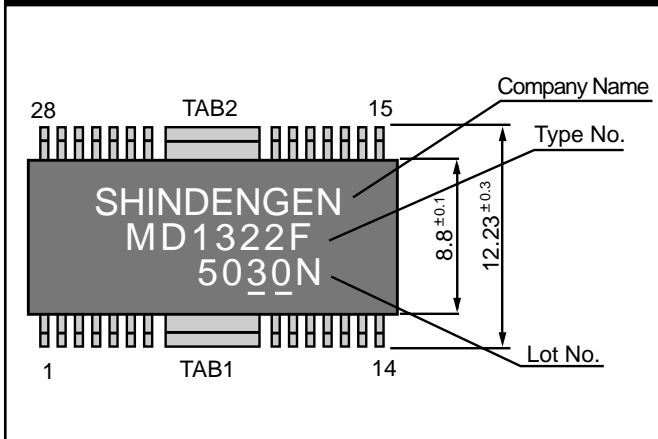

BLOCK DIAGRAM

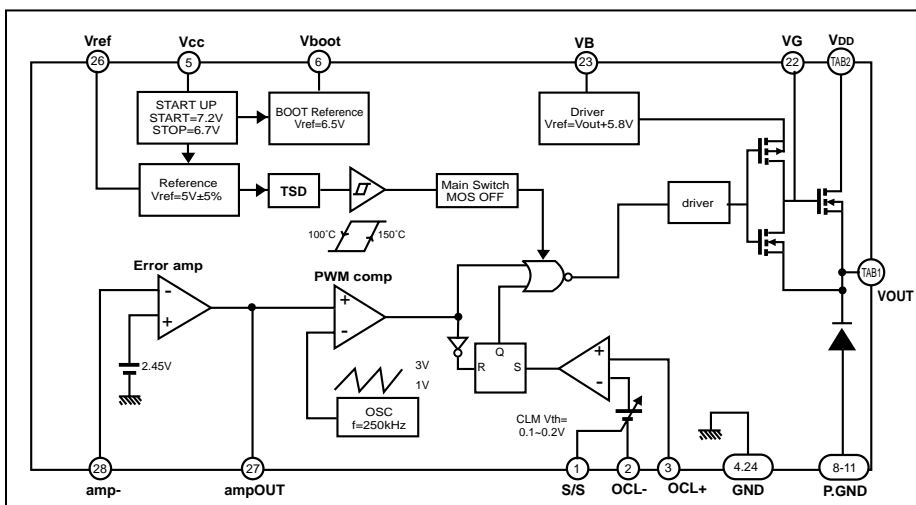

FEATURES

- High efficiency
- Wide input voltage load range 8VDC to 30VDC Up to 3ADC
- Output voltage selectable function 2.5V to 12V
- Internal Switching power device Main MOSFET for switch SBD for rectification
- Fixed 250kHz PWM frequency Without external resistor and capacitor
- Overcurrent protection
- Thermal shutdown function

PIN ASSIGNMENT

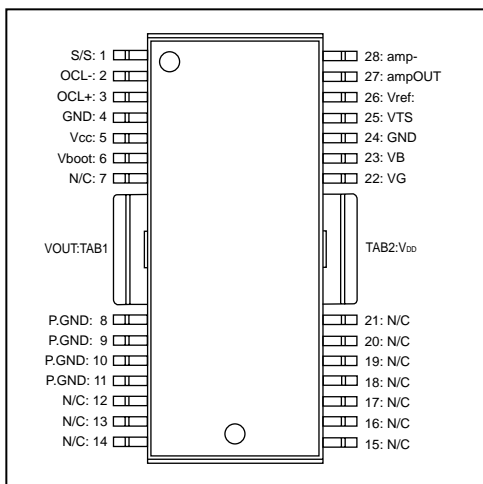

- **Vref** - Temperature compensated internal voltage. You can pull 1mA maximum for external circuit.
- **OSC** - Uses internal oscillator without external component. Frequency (Saw tooth wave form) is trimmed to 250kHz on chip.
- **Error Amp** - Error Amp detects output voltage of DC-DC converter and controls PWM signal. You can adjust the loop gain when you connect feedback resistor and capacitor between AmpOUT and Amp (-). It will provide stable phase compensation.
- **Overcurrent protection** - Uses pulse-by-pulse current protection. Current will be sensed voltage drop of external current sensing resistor. Threshold of OCL is 0.19V.

Pin#	Symbol	Function description
1	S/S	Capacitor for softstart
2	OCL-	Overcurrent protection (OCL) (-)
3	OCL+	Overcurrent protection (OCL) (+)
4	GND	Signal GND
5	Vcc	Input voltage
6	Vboot	High side drive supply for main MOS
7	N/C	Non-connection
8 - 11	P.GND	Power GND
12 - 21	N/C	Non-connection
22	VG	Gate terminal of main MOS
23	VB	Bootstrap capacitor between VB and VOUT
24	GND	Signal GND
25	VTS	Output voltage selectable terminal
26	Vref	Internal voltage reference
27	AmpOUT	Error Amp out
28	amp-	Error Amp (-) input
TAB1	VOUT	Power stage output
TAB2	VDD	Drain of main MOS Switch

2.5V-12V Output MD1322F

ABSOLUTE MAXIMUM RATINGS (Ta=25°C)

Parameter	Symbol	Rating	Units
Line voltage	V _{IN}	32	V
Output MOS input voltage	V _{DD}	32	V
Output current (AVE)	I _{OUTAVE}	3	A
Output Current (PEAK)	I _{OUTPEAK}	4	A
OCL-,OCL+terminal voltage	V _{OCL}	5.5	V
Storage temperature	T _{stg}	-40 ~ 150	°C
Junction temperature	T _j	150	°C

RECOMMENDED OPERATION CONDITIONS

Parameter	Recommendation	Units
Input voltage	8 ~ 30	V
Output voltage setting range	2.5 ~ 12	V
Operation temperature	-10 ~ 80	°C

OUTPUT CURRENT DERATING FOR 5.3V OR HIGHER OUTPUT

Output setting voltage	Output current
2.5V ~5.3V	3A
≤ 6V	2.5V
≤ 8V	2A
≤ 12V	1.5A

ELECTRICAL CHARACTERISTICS (Ta=25°C)

Parameter	Symbol	Conditions	MIN	TYP	MAX	Units
High side MOS D - S voltage	V _{dss}	I _D =1mA, V _{GS} =0V	32	-	-	V
High side MOS Drain interruption current	I _{dss}	V _{DS} =30V, V _{GS} =0V	-	-	10	uA
High side MOS Drain-source ON resistance	R _{on}	I _D =1.2A, V _{GS} =4V	-	140	250	mΩ
High side MOS Source-drain Di forward voltage	V _{SD}	I _S =1.2A, V _{DS} =0V	-	-	1.5	V
Low side SBD Peak reverse voltage	V _{RM}	-	40	-	-	V
Low side SBD Forward voltage	V _F	I _F =1.2A	-	-	0.55	V
Low side SBD Reverse current	I _R	V _R =V _{RM}	-	-	2	mA
Start voltage	V _{CC_start}	-	6.5	7.2	7.9	V
Stop voltage	V _{CC_stop}	-	6.0	6.7	7.4	V
Stop-start voltage hysteresis	V _{CC_hys}	-	-	0.5	-	V
Current consumption	I _{CC}	V _{CC} =8V ~ 30V	-	8	10	mA
BOOT terminal voltage	V _{boot}	V _{CC} =8V ~ 30V	5.4	6.5	7.6	V
Internal reference voltage	V _{ref}	V _{CC} =8V ~ 30V	4.75	5	5.25	V
Initial oscillation frequency	f _{osc}	V _{CC} =24V	212.5	250	287.5	kHz
Overcurrent threshold voltage	V _{th_OCL}	V _{CC} =24V	0.162	0.19	0.218	V
Softstart terminal current	I _{S/S}	V _{CC} =24V	-20	-12.5	-5	uA
Error amplifier reference voltage	V _{amp}	V _{CC} =8V ~ 30V	2.4	2.45	2.5	V
Overcurrent protection operating temperature	T _{TSD}	-	-	150	-	°C