

192MHz – 400MHz Low Phase Noise PECL VCXO (12 – 25MHz Crystal)

FEATURES

- Low phase noise output for the 192MHz to 400MHz range (-134 dBc at 10kHz offset).
- PECL output.
- 12 to 25MHz crystal input.
- Integrated crystal load capacitor: no external load capacitor required.
- Output Enable selector.
- 3.3V operation.
- Available in 16 Pin TSSOP.

PIN CONFIGURATION

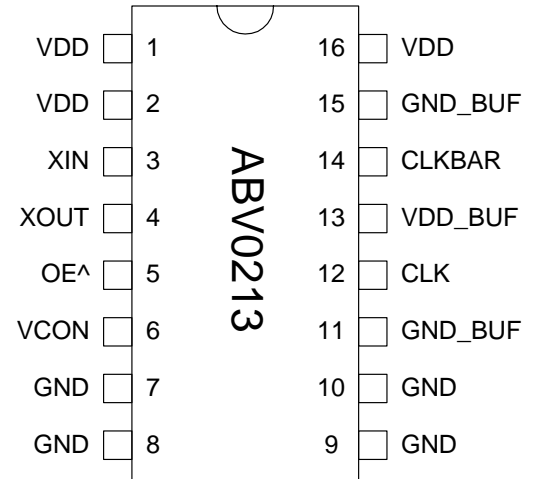

Note: ^ denotes internal pull up

$$F_{OUT} = F_{XIN} \times 16$$

DESCRIPTION

The ABV0213 is a monolithic low jitter and low phase noise (-134dBc/Hz @ 10kHz offset) VCXO IC with PECL output, for 192MHz to 400MHz output range. It provides a low phase noise reference frequency using a low cost crystal.

The chip delivers an output frequency of $F_{XIN} \times 16$. This makes the ABV0213 ideal for a wide range of applications.

OE (Pin 5)	Output State
0	Tri-state
1 (Default)	Output enabled

BLOCK DIAGRAM

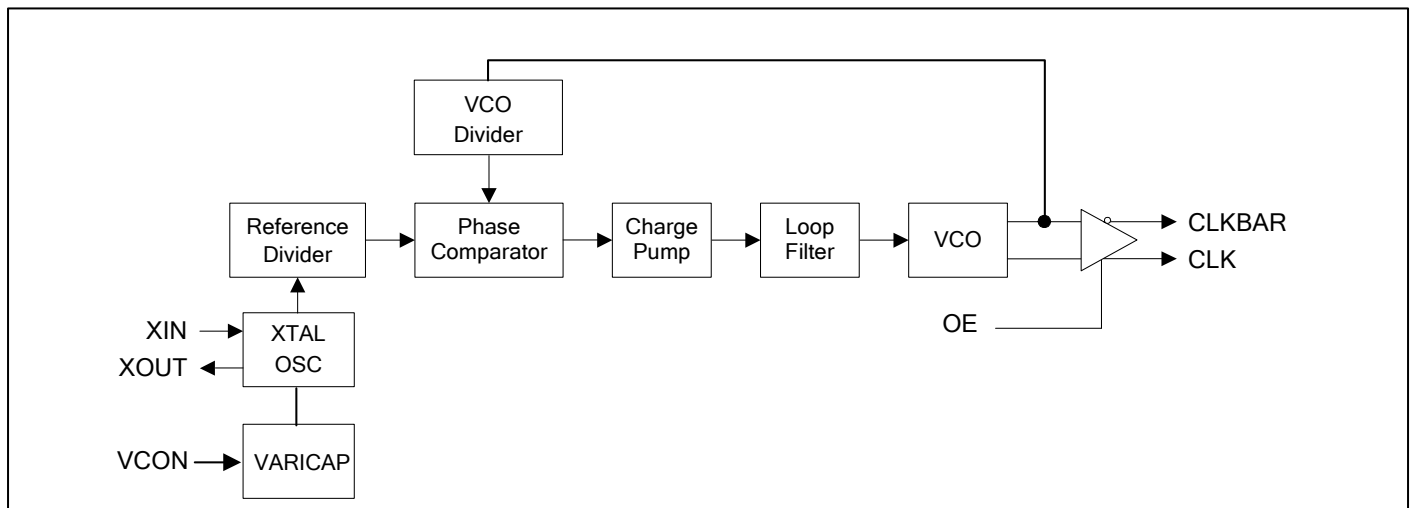

192MHz – 400MHz Low Phase Noise PECL VCXO (12 – 25MHz Crystal)

PIN DESCRIPTIONS

Name	Number	Type	Description
VDD	1,2,16	P	Power supply.
XIN	3	I	Crystal input. See Crystal Specifications on page 2.
XOUT	4	I	Crystal output. See Crystal Specifications on page 2.
OE	5	I	Output enable input. Disables (tri-state) output when low. Internal pull-up enables output by default if pin is not connected to low.
VCON	6	-	Voltage Control input.
GND	7,8,9,10	P	Ground.
GND_BUF	11,15	P	Ground for output buffers.
CLK	12	O	True clock output.
VDD_BUF	13	P	Power supply for output buffers.
CLKB	14	O	Complementary clock output.

ELECTRICAL SPECIFICATIONS

1. Absolute Maximum Ratings

PARAMETERS	SYMBOL	MIN.	MAX.	UNITS
Supply Voltage	V_{DD}		4.6	V
Input Voltage, dc	V_I	-0.5	$V_{DD}+0.5$	V
Output Voltage, dc	V_O	-0.5	$V_{DD}+0.5$	V
Storage Temperature	T_S	-65	150	°C
Ambient Operating Temperature*	T_A	-40	85	°C
Junction Temperature	T_J		125	°C
Lead Temperature (soldering, 10s)			260	°C
ESD Protection, Human Body Model			2	kV

Exposure of the device under conditions beyond the limits specified by Maximum Ratings for extended periods may cause permanent damage to the device and affect product reliability. These conditions represent a stress rating only, and functional operations of the device at these or any other conditions above the operational limits noted in this specification is not implied.

* Note: Operating Temperature is guaranteed by design for all parts (COMMERCIAL and INDUSTRIAL), but tested for COMMERCIAL grade only.

2. Crystal Specifications

PARAMETERS	SYMBOL	CONDITIONS	MIN.	TYP.	MAX.	UNITS
Crystal Resonator Frequency	F_{XIN}	Parallel Fundamental Mode	12		25	MHz
Crystal Loading Rating	$C_L (xtal)$	At VCON = 1.65V		9.5		pF
Crystal Pullability	$C_0/C_1 (xtal)$	AT cut			250	-
Recommended ESR	R_E	AT cut			30	Ω

192MHz – 400MHz Low Phase Noise PECL VCXO (12 – 25MHz Crystal)

3. General Electrical Specifications

PARAMETERS	SYMBOL	CONDITIONS	MIN.	TYP.	MAX.	UNITS
Supply Current, Dynamic (with Loaded Outputs)	I _{DD}	PECL			80	mA
Operating Voltage	V _{DD}		2.97		3.63	V
Output Clock Duty Cycle		@ V _{DD} – 1.3V (PECL)	45	50	55	%
Short Circuit Current				±50		mA

4. Jitter and Phase Noise Specification

PARAMETERS	CONDITIONS	MIN.	TYP.	MAX.	UNITS
Period jitter RMS	With capacitive decoupling between VDD and GND.		5		ps
Accumulated jitter RMS	With capacitive decoupling between VDD and GND. Over 10,000 cycles.		11		ps
Phase Noise relative to carrier	311MHz @100Hz offset		-90		dBc/Hz
Phase Noise relative to carrier	311MHz @1kHz offset		-115		dBc/Hz
Phase Noise relative to carrier	311MHz @10kHz offset		-125		dBc/Hz
Phase Noise relative to carrier	311MHz @100kHz offset		-119		dBc/Hz

5. Voltage Control Crystal Oscillator

PARAMETERS	SYMBOL	CONDITIONS	MIN.	TYP.	MAX.	UNITS
VCXO Stabilization Time *	T _{VCXOSTB}	From power valid			10	ms
VCXO Tuning Range		F _{XIN} = 12 – 25MHz; XTAL C ₀ /C ₁ < 250 0V ≤ VCON ≤ 3.3V		500		ppm
CLK output pullability		VCON=1.65V, ±1.65V	±200			ppm
VCXO Tuning Characteristic				150		ppm/V
Pull range linearity					10	%
VCON pin input impedance			2000			kΩ
VCON modulation BW		0V ≤ VCON ≤ 3.3V, -3dB	25			kHz

Note: Parameters denoted with an asterisk (*) represent nominal characterization data and are not production tested to any specific limits.

192MHz – 400MHz Low Phase Noise PECL VCXO (12 – 25MHz Crystal)

6. PECL Electrical Characteristics

PARAMETERS	SYMBOL	CONDITIONS	MIN.	MAX.	UNITS
Output High Voltage	V_{OH}	$R_L = 50 \Omega$ to $(V_{DD} - 2V)$ (see figure)	$V_{DD} - 1.025$		V
Output Low Voltage	V_{OL}			$V_{DD} - 1.620$	V

7. PECL Switching Characteristics

PARAMETERS	SYMBOL	CONDITIONS	MIN.	TYP.	MAX.	UNITS
Clock Rise Time	t_r	@20/80% - PECL		0.6	1.5	ns
Clock Fall Time	t_f	@80/20% - PECL		0.5	1.5	ns

PECL Levels Test Circuit

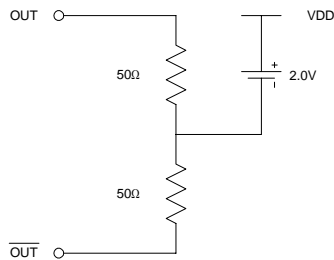

PECL Output Skew

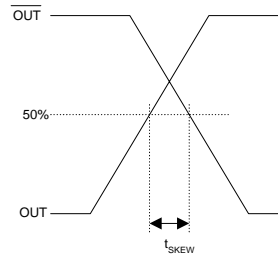

PECL Transition Time Waveform

