

SG30JC6M

60V 30A

特長

- $T_j=150^{\circ}\text{C}$
- フルモールド
- 低 $I_R=0.15\text{mA}$
- 熱暴走を起こしにくい

Feature

- $T_j=150^{\circ}\text{C}$
- Full Molded
- Low $I_R=0.15\text{mA}$
- Resistance for thermal run-away

用途

- ノートPC、LCDモニタ等アダプタの2次側整流
- 各種電源の2次側整流
- DC/DCコンバータ
- 冗長化電源の逆流防止

Main Use

- Secondary rectification for Adapter of Note-PC, LCD monitor, etc.
- Secondary Rectification
- DC/DC Converter
- Reverse current protection

■外観図 OUTLINE

Package : FTO-220G

Unit:mm

Weight 1.54g(Typ)

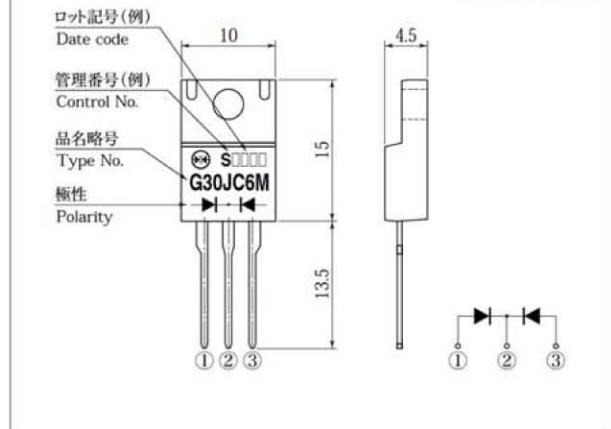

外形図については新電元Webサイトをご参照下さい。捺印表示については捺印仕様をご確認下さい。

For details of the outline dimensions, refer to our web site. As for the marking, refer to the specification "Marking, Terminal Connection".

■定格表 RATINGS

●絶対最大定格 Absolute Maximum Ratings (指定のない場合 $T_c = 25^{\circ}\text{C}$)

項目 Item	記号 Symbol	条件 Conditions	品名 Type No.	SG30JC6M	単位 Unit
保存温度 Storage Temperature	T_{stg}			-55~150	$^{\circ}\text{C}$
接合部温度 Operation Junction Temperature	T_j			150	$^{\circ}\text{C}$
せん頭逆電圧 Maximum Reverse Voltage	V_{RM}			60	V
繰り返しせん頭サージ逆電圧 Repetitive Peak Surge Reverse Voltage	V_{RRSM}	パルス幅0.5ms, duty 1/40 Pulse width 0.5ms, duty 1/40		65	V
出力電流 Average Rectified Forward Current	I_o	50Hz正弦波, 抵抗負荷, フィン付き, 1素子当りの出力電流平均値 $I_o/2$, $T_c=90^{\circ}\text{C}$ 50Hz sine wave, Resistance load, With heatsink, Per diode $I_o/2$, $T_c=90^{\circ}\text{C}$		30	A
せん頭サージ順電流 Peak Surge Forward Current	I_{FSM}	50Hz正弦波, 非繰り返し1サイクルせん頭値, $T_j=25^{\circ}\text{C}$ 50Hz sine wave, Non-repetitive 1 cycle peak value, $T_j=25^{\circ}\text{C}$		250	A
締め付けトルク Mounting Torque	TOR	(推奨値: 0.3N·m) (Recommended torque: 0.3N·m)		0.5	N·m

●電氣的・熱的特性 Electrical Characteristics (指定のない場合 $T_c = 25^{\circ}\text{C}$)

順電圧 Forward Voltage	V_F	$I_F = 15\text{A}$, パルス測定, 1素子当りの規格値 Pulse measurement, Per diode	TYP 0.65 MAX 0.69	V
逆電流 Reverse Current	I_R	$V_R = 60\text{V}$, パルス測定, 1素子当りの規格値 Pulse measurement, Per diode	MAX 0.15	mA
接合容量 Junction Capacitance	C_j	$f = 1\text{MHz}$, $V_R = 10\text{V}$, 1素子当りの規格値 Per diode	TYP 325	pF
熱抵抗 Thermal Resistance	θ_{jc}	接合部・ケース間 Junction to case	MAX 2.2	$^{\circ}\text{C}/\text{W}$

■特性図 CHARACTERISTIC DIAGRAMS

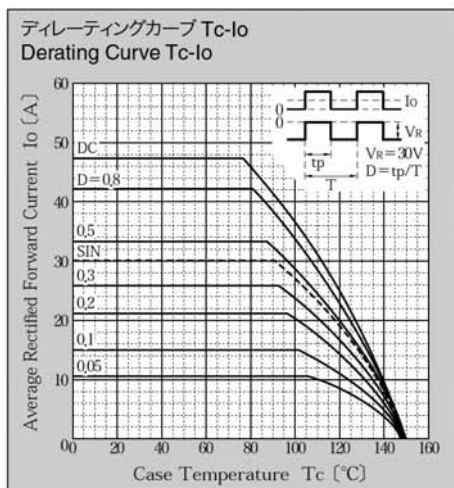
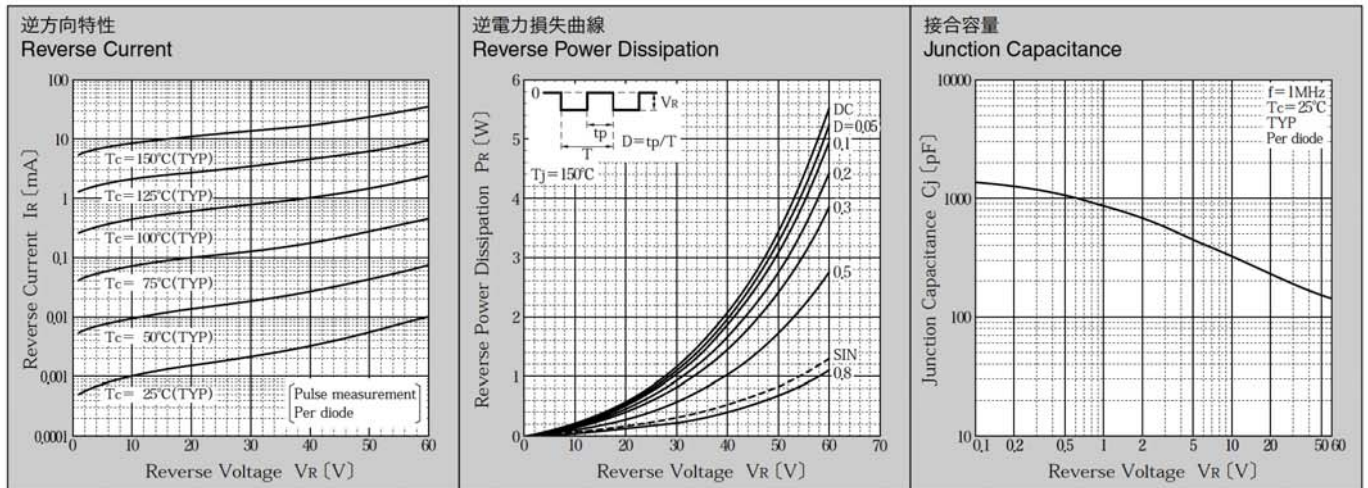
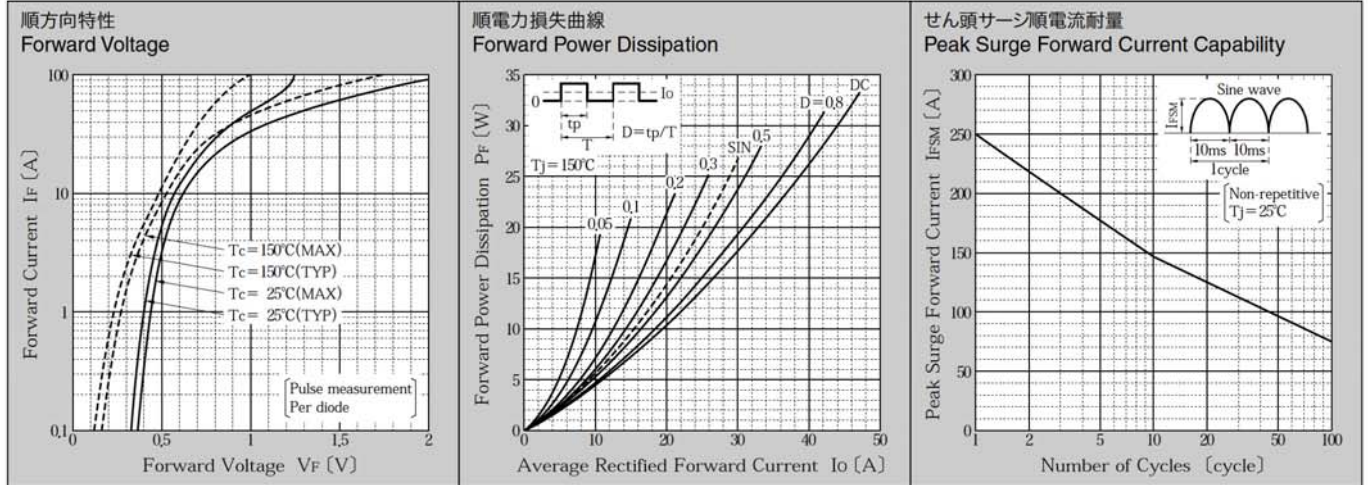

* Sine waveは50Hzで測定しています。
* 50Hz sine wave is used for measurements.
* 半導体製品の特性は一般的にバラツキを持っています。
Typicalは統計的な実力を表しています。
* Semiconductor products generally have characteristic variation.
Typical is a statistical average of the device's ability.