



Features

- Size: 8 mm diameter, 10 mm length
- High current rating
- Low capacitance and insertion loss
- Fail-short option available
- RoHS compliant*
-  UL Recognized

Applications

- Telecommunications equipment
- Industrial equipment/electronics
- Consumer electronics

2046 Series Heavy-Duty 3-Electrode Gas Discharge Tube

Characteristics

Test Methods per ITU-T K.12 and IEC 61643-311.

Characteristic	Model No.				
	2046-09	2046-14	2046-20	2046-23	2046-25
DC Sparkover $\pm 20\%$ @ 100 V/s	90 V	145 V	200 V	230 V	250 V
Impulse Sparkover					
100 V/ μ s	< 600 V	< 500 V	< 500 V	< 600 V	< 600 V
1000 V/ μ s	< 700 V	< 700 V	< 700 V	< 700 V	< 700 V

Characteristic	Model No.				
	2046-35	2046-40	2046-42	2046-47	2046-60
DC Sparkover $\pm 20\%$ @ 100 V/s	350 V	400 V	420 V	470 V	600 V
Impulse Sparkover					
100 V/ μ s	< 700 V	< 800 V	< 800 V	< 900 V	< 1000 V
1000 V/ μ s	< 800 V	< 900 V	< 900 V	< 1000 V	< 1100 V

Insulation Resistance (IR) NOTE 1	50 / 100 / 250 Vdc	> 10 G Ω
Glow Voltage	10 mA	~ 70 V
Arc Voltage	1 A	~ 10 V
Glow-Arc Transition Current		< 1 A
Maximum Capacitance	1 MHz	< 2 pF
Maximum Impulse Discharge Current	20,000 A, 8/20 μ s	1 operation
	10,000 A, 8/20 μ s	10 operations
Nominal Alternating Discharge Current	20 A, 50 Hz, 1 second	1 operation
Impulse Life	200 A 10/1000 μ s	130 operations
DC Holdover Voltage NOTE 2		< 150 ms
Operating Temperature		-30 to +85 °C
Storage Temperature		-40 to +115 °C
Climatic Category (IEC 60068-1)		40 / 90 / 21

Notes:

- UL Recognized component, UL File E153537.
- At delivery AQL 0.65, level II DIN ISO 2859
- Line to Line voltage is approximately 1.8 to 2 times the stated Line to Ground voltage.
- Discharge current rating is total current equally divided between Each Line To Ground (ELTG).

Note 1:	<u>DC Sparkover Voltage</u>	<u>IR Measuring Voltage</u>
	90 V	50 V
	145–400 V	100 V
	420–600 V	250 V

Note 2:	<u>Network Applied</u>	<u>DC Holdover Voltage</u>
	<u>DC Sparkover Voltage</u>	
	90–145 V	52 V
	200–250 V	135 V
	350–600 V	150 V

*RoHS Directive 2002/95/EC Jan. 27, 2003 including annex and RoHS Recast 2011/65/EU June 8, 2011.

Specifications are subject to change without notice.

The device characteristics and parameters in this data sheet can and do vary in different applications and actual device performance may vary over time. Users should verify actual device performance in their specific applications.

2046 Series Heavy-Duty 3-Electrode Gas Discharge Tube

BOURNS®

Product Dimensions

2046-xx-A

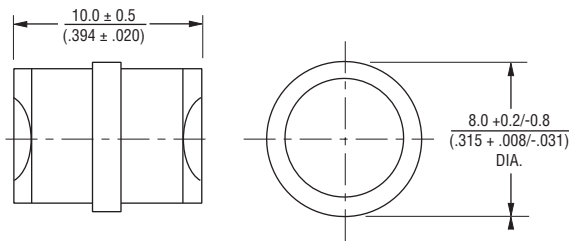

2046-xx-C2F FAIL-SHORT CONFIGURATION

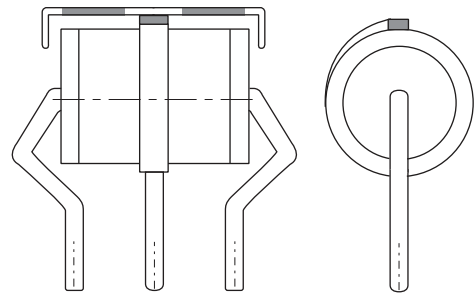

2046-xx-C2 1.0 mm dia. lead wire

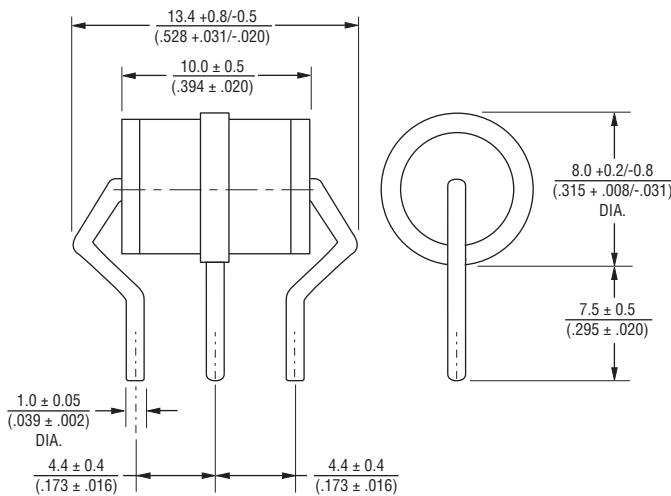

DIMENSIONS: $\frac{\text{MM}}{\text{(INCHES)}}$

How to Order

2046 - xx - xx (F) LF

Model Number Designator

Voltage (Divided by 10)

09 = 90 V	35 = 350 V
14 = 145 V	40 = 400 V
20 = 200 V	42 = 420 V
23 = 230 V	47 = 470 V
25 = 250 V	60 = 600 V

Leads

- A = No leads/Cassette Applications
- C2 = 1.0 mm dia., 4.4 mm spacing

Fail-Short Option

- (Blank) = None
- F = Fail-Short Device (Optional)

RoHS Compliancy

- LF = RoHS Compliant Product

Packaging Specifications

Model 2046 ships standard bulk pack, 100 pieces per tray; 5 trays per inner box; 2 inner boxes per outer pack (1K units).

BOURNS®

Asia-Pacific: Tel: +886-2 2562-4117 • Fax: +886-2 2562-4116

Europe: Tel: +41-41 768 5555 • Fax: +41-41 768 5510

The Americas: Tel: +1-951 781-5500 • Fax: +1-951 781-5700

www.bourns.com

REV. A 05/12

Specifications are subject to change without notice. The device characteristics and parameters in this data sheet can and do vary in different applications and actual device performance may vary over time. Users should verify actual device performance in their specific applications.