

PRODUCT NUMBER (SEE NOTE 2)	CONTACT PLATING		ROHS COMPATIBILITY
	SEPARABLE INTERFACE	PRESS-FIT TAIL	
10028917-001	0.76um MIN GOLD OVER NICKEL	0.5um MIN TIN-LEAD OVER NICKEL	N/A
10028917-001LF		0.5um MIN MATTE TIN OVER NICKEL	SEE NOTE 8

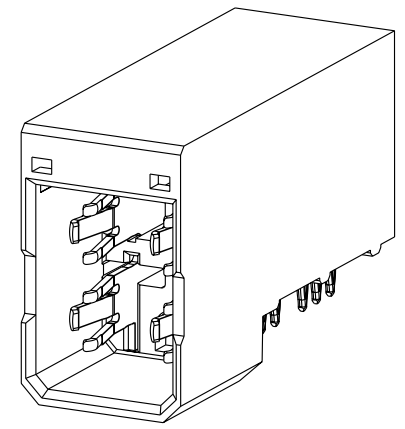

SCALE 2:1

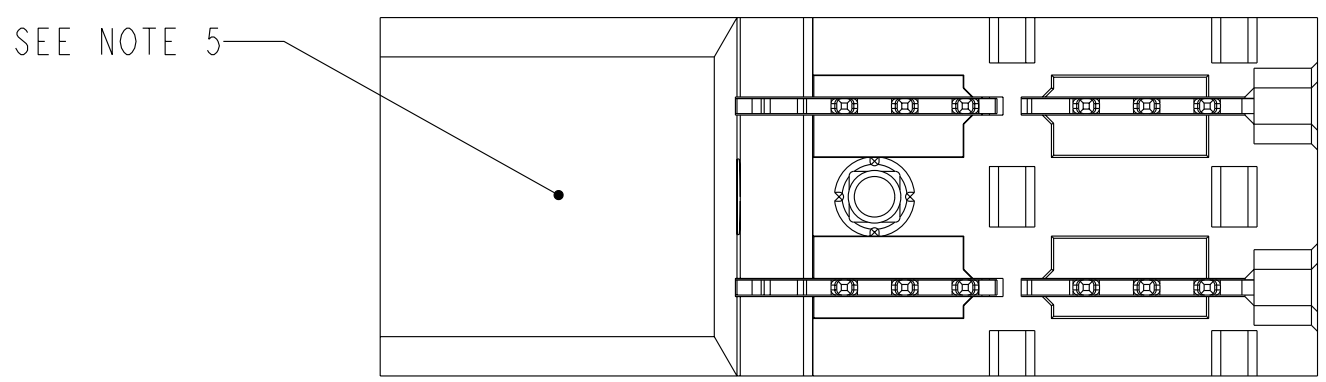
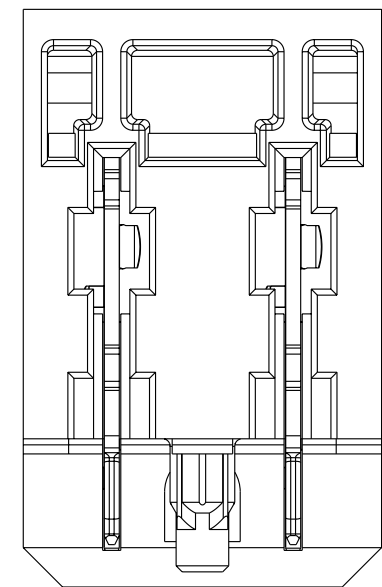
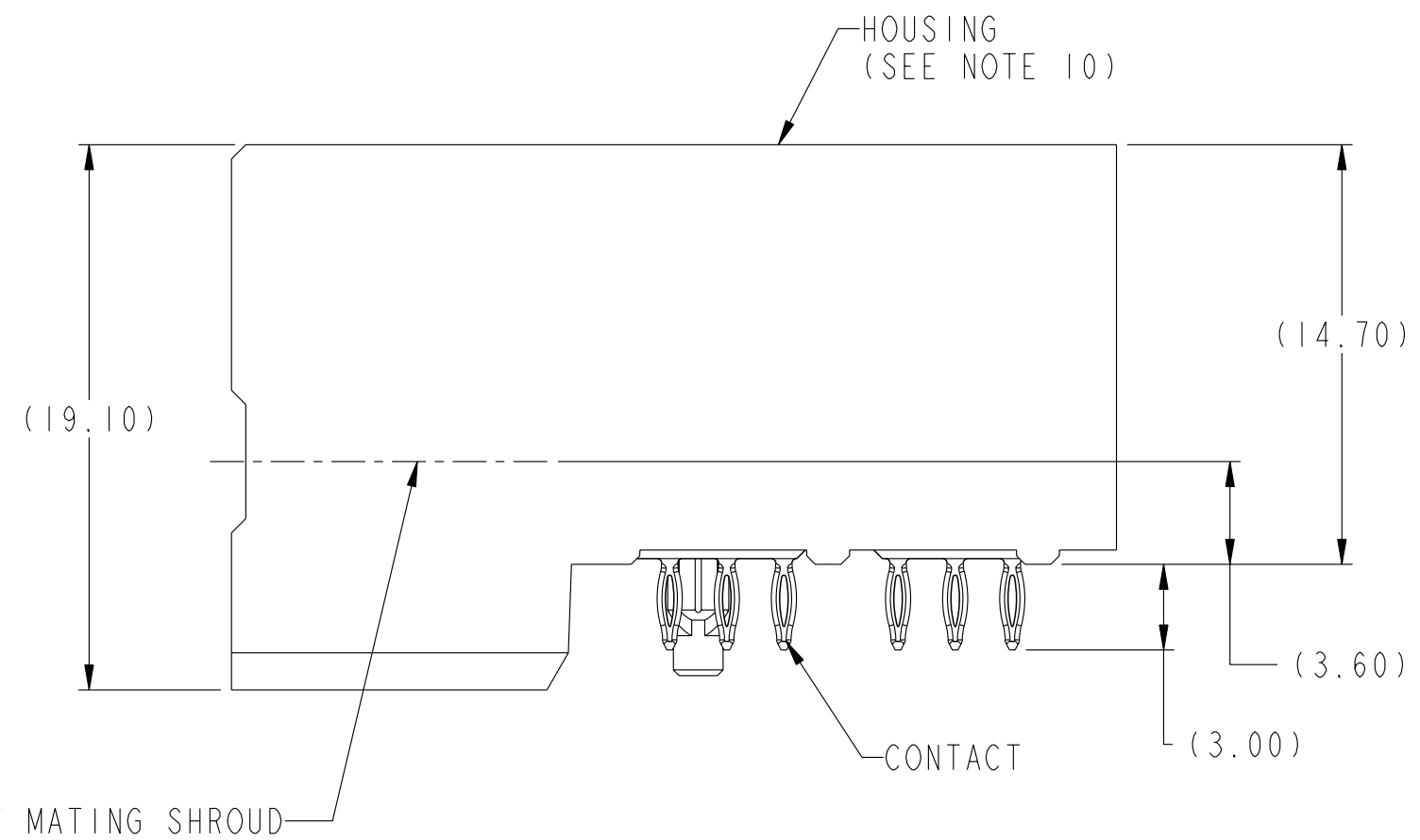
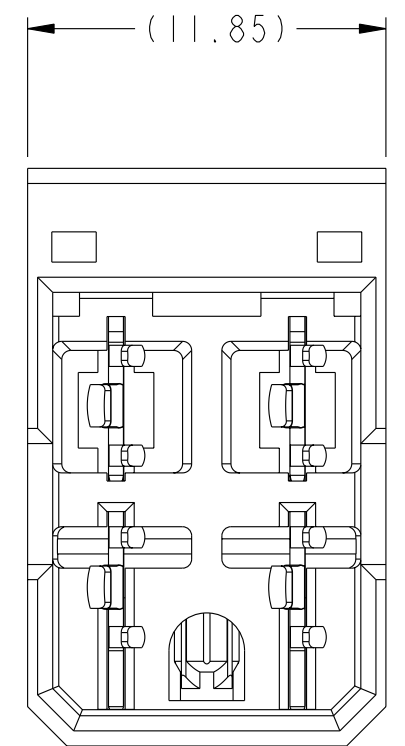
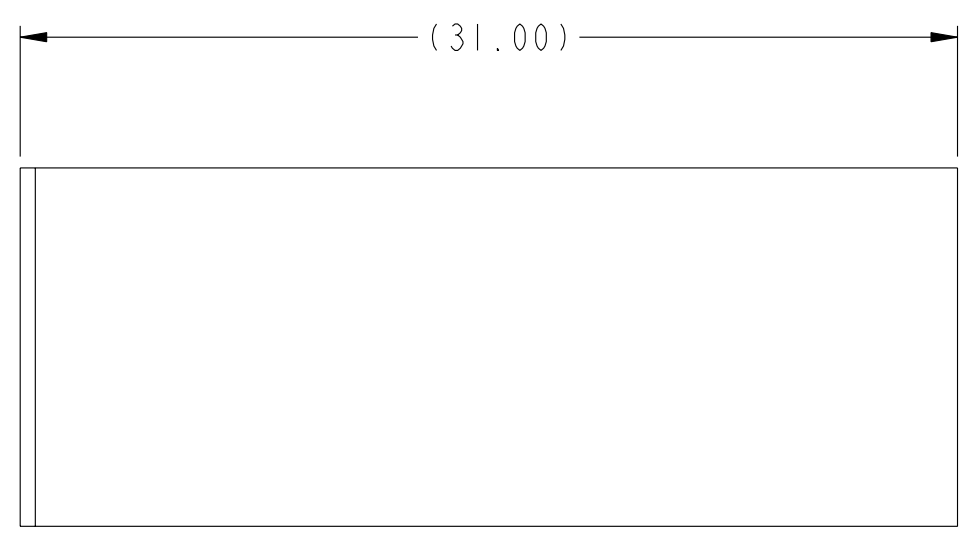

www.fciconnect.com		surface ASME Y14.5	tolerance std ASME Y14.5	projection ASME Y14.5	MM
		TOLERANCES UNLESS OTHERWISE SPECIFIED			
Dr	W. J. SWAIN	2003-05-23	ANGULAR	0.X	±.3
Eng	W. J. SWAIN	2003-05-23	LINEAR	0.XX	±.1
Chr	C. H. TAN	2006-12-21	0° ±2°	0.XXX	±.050
Appr	JOEY NG	2006-12-21	Product family 2mm High Power		size A2
				ECN	Scale 4:1
				Spec ref	S06-0412
				Product family	GS-12-220
FCI		TITLE HEADER ASSEMBLY, 2X2, POWER		dwg no 10028917	Rev. D
		catalog no		CUSTOMER	sheet 1 of 2

rev	ecn no	dr	date
A	V04-0697	WJS	2004-07-07
B	V05-0150	WJS	2005-02-10
C	S05-0301	WJS	2005-10-24
D	S06-0412	LS	2006-12-21
-	-	-	-
-	-	-	-
-	-	-	-

Copyright FCI.  
FCI

TOP LAYER DESCRIPTION	TABLE I PLATED THROUGH-HOLE REQUIREMENTS							
	DRILLED HOLE DIAMETER	COPPER THICKNESS	TIN-LEAD THICKNESS	NICKEL THICKNESS	GOLD THICKNESS	TIN THICKNESS	SILVER THICKNESS	FINISHED HOLE DIAMETER
TIN-LEAD	0.81-0.86 (0.85 DRILL)	0.025 - 0.050	0.005 - 0.015	--	--	--	--	0.65 - 0.80
IMMERSION TIN	0.81-0.86 (0.85 DRILL)	0.025 - 0.050	--	--	--	0.9 - 1.5um	--	0.70 - 0.80
IMMERSION SILVER	0.81-0.86 (0.85 DRILL)	0.025 - 0.050	--	--	--	--	0.15 - 0.65um	0.70 - 0.80
COPPER (SEE NOTE 11)	0.81-0.86 (0.85 DRILL)	0.025 - 0.050	--	--	--	--	--	0.70 - 0.80
GOLD	0.81-0.86 (0.85 DRILL)	0.025 - 0.050	--	0.003 - 0.007	FLASH UP TO 0.0002	--	--	0.69 - 0.80

- NOTES:
- CONNECTOR MATERIALS:  
HOUSING: HIGH TEMPERATURE THERMOPLASTIC, BLACK  
UL 94V-0 COMPLIANT  
CONTACT: HIGH PERFORMANCE COPPER ALLOY
  - "LF" SUFFIX DENOTES "LEAD-FREE"
  - PRODUCT SPECIFICATION: GS-12-220
  - APPLICATION SPECIFICATION: GS-20-023
  - PRODUCT MARKING (PRODUCT NUMBER & LOT CODE) ON HOUSING.
  - MINIMUM NOMINAL PCB THICKNESS: 1.6mm
  - REFER TO CUSTOMER DRAWING SK10035911 FOR INFORMATION REGARDING PCB LAYOUT OF POWER AND GUIDE MODULES RELATIVE TO SIGNAL MODULES.
  - PRODUCT MEETS EUROPEAN UNION DIRECTIVES AND OTHER COUNTRY REGULATIONS AS DESCRIBED IN FCI SPECIFICATION GS-22-008.
  - PACKAGING MEETS FCI SPECIFICATION GS-14-920.
  - HOUSING COMPONENT WILL WITHSTAND EXPOSURE TO 260°C PEAK TEMPERATURE FOR 60 SECONDS IN A CONVECTION, INFRA-RED, OR VAPOR PHASE REFLOW OVEN.
  - COPPER PLATING THICKNESS IN CENTER OF VIA-HOLE CAN BE NO MORE THAN 0.003 LESS THAN OTHER AREAS.

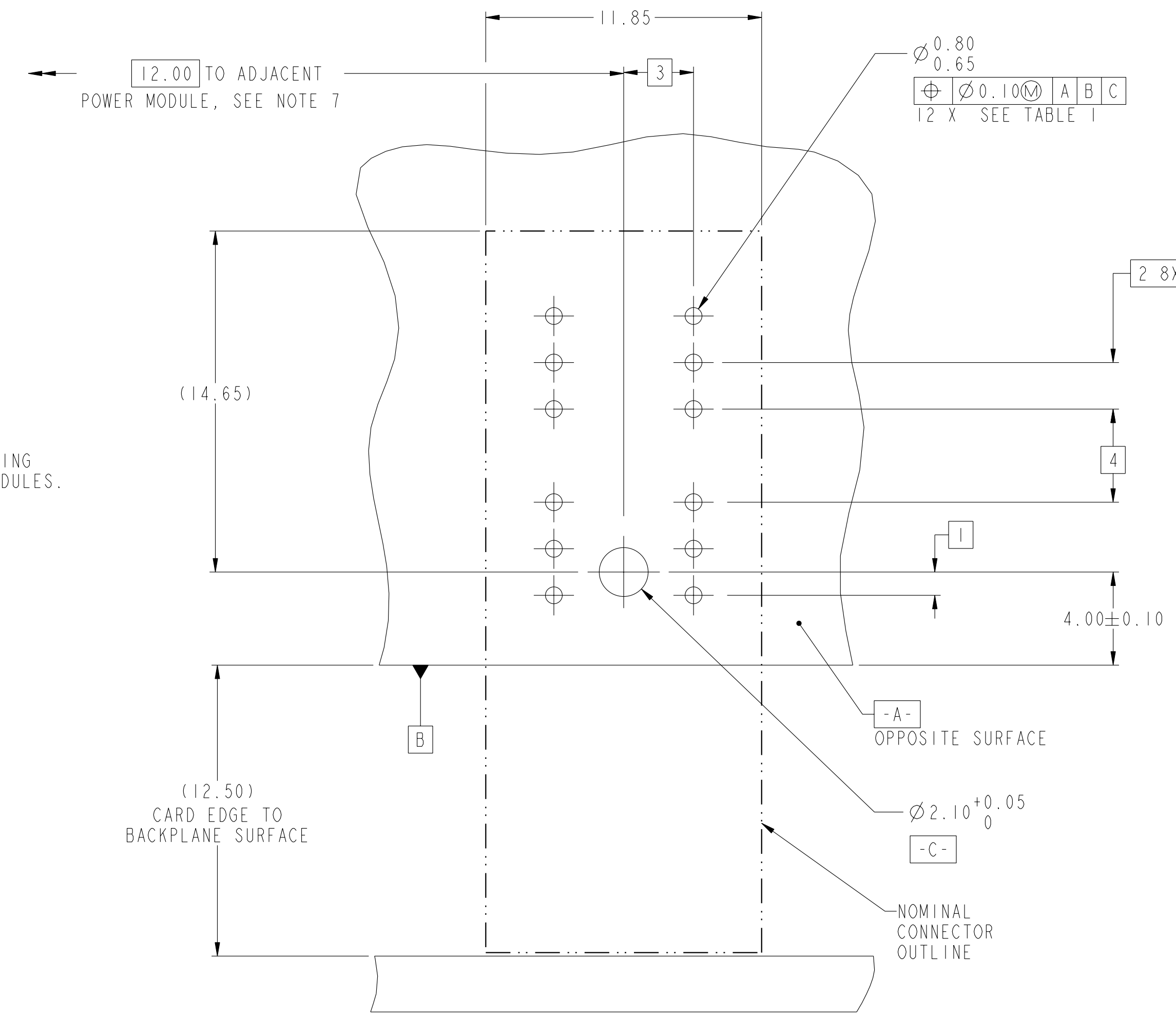

RECOMMENDED PCB LAYOUT,  
COMPONENT SIDE  
SEE NOTE 6  
SCALE 6:1

Copyright FCI. FCI

FCI	TITLE	HEADER ASSEMBLY, 2X2, POWER	dwg no 10028917	Rev. D
	CATALOG NO	CUSTOMER		