

16-bit Proprietary Microcontroller

CMOS

F²MC-16LX MB90580B Series

MB90583B/587/F583B/V580B

■ DESCRIPTION

The MB90580B series is a line of general-purpose, Fujitsu 16-bit microcontrollers designed for process control applications which require high-speed real-time processing, such as consumer products.

While inheriting the AT architecture of the F²MC*¹ family, the instruction set for the F²MC-16LX CPU core of the MB90580B series incorporates additional instructions for high-level languages, supports extended addressing modes, and contains enhanced multiplication and division instructions as well as a substantial collection of improved bit manipulation instructions. In addition, the MB90580B has an on-chip 32-bit accumulator which enables processing of long-word data.

The peripheral resources integrated in the MB90580B series include: an 8/10-bit A/D converter, an 8-bit D/A converter, UARTs (SCI) 0 to 4, an 8/16-bit PPG timer, 16-bit I/O timers (16-bit free-run timer, input capture units (ICUs) 0 to 3, output compare units (OCUs) 0 and 1), and an IEBus™ controller *².

Notes: *1: F²MC stands for FUJITSU Flexible Microcontroller, a registered trademark of FUJITSU LIMITED.

*2: IEBus™ is a trademark of NEC Corporation.

■ FEATURES

- Minimum execution time: 62.5 ns/4 MHz oscillation (Uses PLL clock multiplication) maximum multiplier = 4
- Maximum memory space
16 Mbyte
Linear/bank access

(Continued)

■ PACKAGES

100 pin plastic LQFP

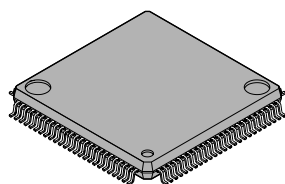

(FPT-100P-M05)

100 pin plastic QFP

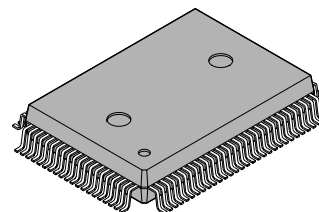

(FPT-100P-M06)

MB90580B Series

(Continued)

- Instruction set optimized for controller applications
 - Supported data types: bit, byte, word, and long-word types
 - Standard addressing modes: 23 types
 - 32-bit accumulator enhancing high-precision operations
 - Signed multiplication/division and extended RETI instructions
- Enhanced high level language (C) and multitasking support instructions
 - Use of a system stack pointer
 - Symmetrical instruction set and barrel shift instructions
- Program patch function (for two address pointers)
- Enhanced execution speed: 4 byte instruction queue
- Enhanced interrupt function
 - Up to eight priority levels programmable
 - External interrupt inputs: 8 lines
- Automatic data transmission function independent of CPU operation
 - Up to 16 channels for the extended intelligent I/O service
 - DTP request inputs: 8 lines
- Internal ROM
 - FLASH: 128 Kbyte
 - MASKROM: 128 Kbyte (MB90583B) , 64 Kbyte (MB90587)
- Internal RAM
 - FLASH: 6 Kbyte
 - MASKROM: 6 Kbyte (MB90583B) , 4 Kbyte (MB90587)
- General-purpose ports
 - Up to 77 channels (Input pull-up resistor settable for: 24 channels. Output open drain settable for: 8 channels)
- IEBus™ controller*
 - Three different data transfer rates selectable
 - Mode 0: 3.9 Kbps (16 bytes/frame)
 - Mode 1: 17.0 Kbps (32 bytes/frame)
 - Mode 2: 26.0 Kbps (128 bytes/frame)
 - *: IEBus™ is a trademark of NEC Corporation.
- A/D Converter (RC) : 8 ch
 - 8/10-bit resolution
 - Conversion time: 34.7 μs (Min.) , 12 MHz operation
- D/A Converter: 2 ch
 - 8-bit resolutions
 - Setup time: 12.5 μs
- UART : 5 ch
- 8/16 bit PPG : 1 ch
 - 8 bits × 2 channels: 16 bits × 1 channel: Mode switching function provided
- 16 bit reload timer: 3 ch
- 16-bit PWC timer: 1 channel
 - Noise filter provided. Available to pulse width counter
- 16 bit I/O timer
 - Input capture : 4 ch
 - Output compare : 2 ch
 - Free run timer: 1 ch
- Internal clock generator
- Time-base counter/watchdog timer: 18-bit

(Continued)

(Continued)

- Clock monitor function integrated
- Low-power consumption mode
 - Sleep mode
 - Stop mode
 - Hardware standby mode
 - CPU intermittent operation mode
- Package: LQFP-100 / QFP-100
- CMOS technology

MB90580B Series

■ PRODUCT LINEUP

Part number Item	MB90587	MB90583B	MB90F583B	MB90V580B
Classification	Mass-produced products (MASK ROM)		Mass-produced products (Flash ROM)	Development/ evaluation product
ROM size	64 Kbytes	128 Kbytes	128 Kbytes	None
RAM size	4 Kbytes	6 Kbytes	6 Kbytes	6 Kbytes
Emulator-specific power supply *1	—	—	—	None
CPU functions	The number of instructions: 340 Instruction bit length: 8 bits, 16 bits Instruction length: 1 byte to 7 bytes Data bit length: 1 bit, 8 bits, 16 bits Minimum execution time: 62.5 ns (at machine clock of 16 MHz) Interrupt processing time: 1.5 ms (at machine clock of 16 MHz, minimum value)			
Ports	General-purpose I/O ports (CMOS output) : 45 General-purpose I/O port (Can be set as open-drain) : 8 General-purpose I/O ports (Input pull-up resistors available) : 24 Total: : 77			
IEBus™ controller	None	Communication mode: Half-duplex, asynchronous communication Multi-master system Access control: CDMA/CD Three modes selectable for different transmission speeds Transmit buffer: 8-byte FIFO buffer Receive buffer: 8-byte FIFO buffer		
Timebase timer	18-bit counter Interrupt interval: 1.024 ms, 4.096 ms, 16.384 ms, 131.072 ms (At oscillation of 4 MHz)			
Watchdog timer	Reset generation interval: 3.58 ms, 14.33 ms, 57.23 ms, 458.75 ms (at oscillation of 4 MHz, minimum value)			
Clock timer	15-bit counter Interrupt interval: 1 s, 0.5 s, 0.25 s, 31.25 ms (At oscillation of 32.768 kHz)			
8/16-bit PPG timer	Number of channels: 1 (8-bit × 2 channels) PPG operation of 8-bit or 16-bit A pulse wave of given intervals and given duty ratios can be output. Pulse interval: 62.5 ns to 1 ms (at oscillation of 4 MHz, machine clock of 16 MHz)			
16-bit reload timer	Number of channels: 3 Event count provided Interval: 125 ns to 131 ms (at oscillation of 4 MHz, machine clock of 16 MHz)			
PWC timer	Number of channels: 1 Timer function (select the counter timer from three internal clocks.) Pulse width measuring function (select the counter timer from three internal clocks.)			

(Continued)

MB90580B Series

(Continued)

Part number		MB90587	MB90583B	MB90F583B	MB90V580B
Item					
16-bit I/O timer	16-bit free run timer	Number of channels: 1 Overflow interrupts			
	Output compare (OCU)	Number of channels: 2 Pin input factor: A match signal of compare register			
	Input capture (ICU)	Number of channels: 4 Rewriting a register value upon a pin input (rising, falling, or both edges)			
DTP/external interrupt circuit		Number of inputs: 8 Started by a rising edge, a falling edge, an "H" level input, or an "L" level input. External interrupt circuit or extended intelligent I/O service (EI ² OS) can be used.			
Delayed interrupt generation module		An interrupt generation module for switching tasks used in real time operating systems.			
UART0, 1, 2, 3, 4		Clock synchronized transmission (62.5 Kbps to 1 Mbps) Clock asynchronized transmission (1202 bps to 9615 bps) Transmission can be performed by bi-directional serial transmission or by master/slave connection.			
A/D converter		Resolution: 8/10-bit changeable Number of inputs: 8 One-shot conversion mode (converts selected channel only once) Scan conversion mode (converts two or more successive channels and can program up to 8 channels.) Continuous conversion mode (converts selected channel repeatedly) Stop conversion mode (converts selected channel and stop operation repeatedly)			
D/A converter		8-bit resolution Number of channels: 2 channels Based on the R-2R system			
Low-power consumption (standby) mode		Sleep/stop/CPU intermittent operation/clock timer/hardware standby			
Process		CMOS			
Power supply voltage for operation*		4.5 V to 5.5 V *2			

*1 : It is setting of DIP switch S2 when Emulation pod (MB2145-507) is used.

Please refer to the MB2145-507 hardware manual (2.7 Emulator-specific Power Pin) about details.

*2 : Varies with conditions such as the operating frequency (See section "■ ELECTRICAL CHARACTERISTICS").

Assurance for the MB90V580B is given only for operation with a tool at a power supply voltage of 4.5 V to 5.5 V, an operating temperature of 0 to +25 °C, and an operating frequency of 1 MHz to 16 MHz.

■ PACKAGE AND CORRESPONDING PRODUCTS

Package	MB90583B	MB90587	MB90F583B
FPT-100P-M05	○	○	○
FTP-100P-M06	○	○	○

○ : Available × : Not available

Note: For more information about each package, see section "■ PACKAGE DIMENSIONS".

MB90580B Series

■ DIFFERENCES AMONG PRODUCTS

Memory Size

In evaluation with an evaluation product, note the difference between the evaluation product and the product actually used. The following items must be taken into consideration.

- The MB90V580B does not have an internal ROM, however, operations equivalent to chips with an internal ROM can be evaluated by using a dedicated development tool, enabling selection of ROM size by settings of the development tool.
- In the MB90V580B, images from FF4000_H to FFFFFFF_H are mapped to bank 00, and FE0000_H to FF3FFF_H to mapped to bank FE and FF only. (This setting can be changed by configuring the development tool.)
- In the MB90583B/587/F583B, images from FF4000_H to FFFFFFF_H are mapped to bank 00, and FF0000_H to FF3FFF_H to bank FF only.

IEBus™ Controller

- MB90587 does not have an IEBus™ Controller.

PIN ASSIGNMENT

(TOP VIEW)

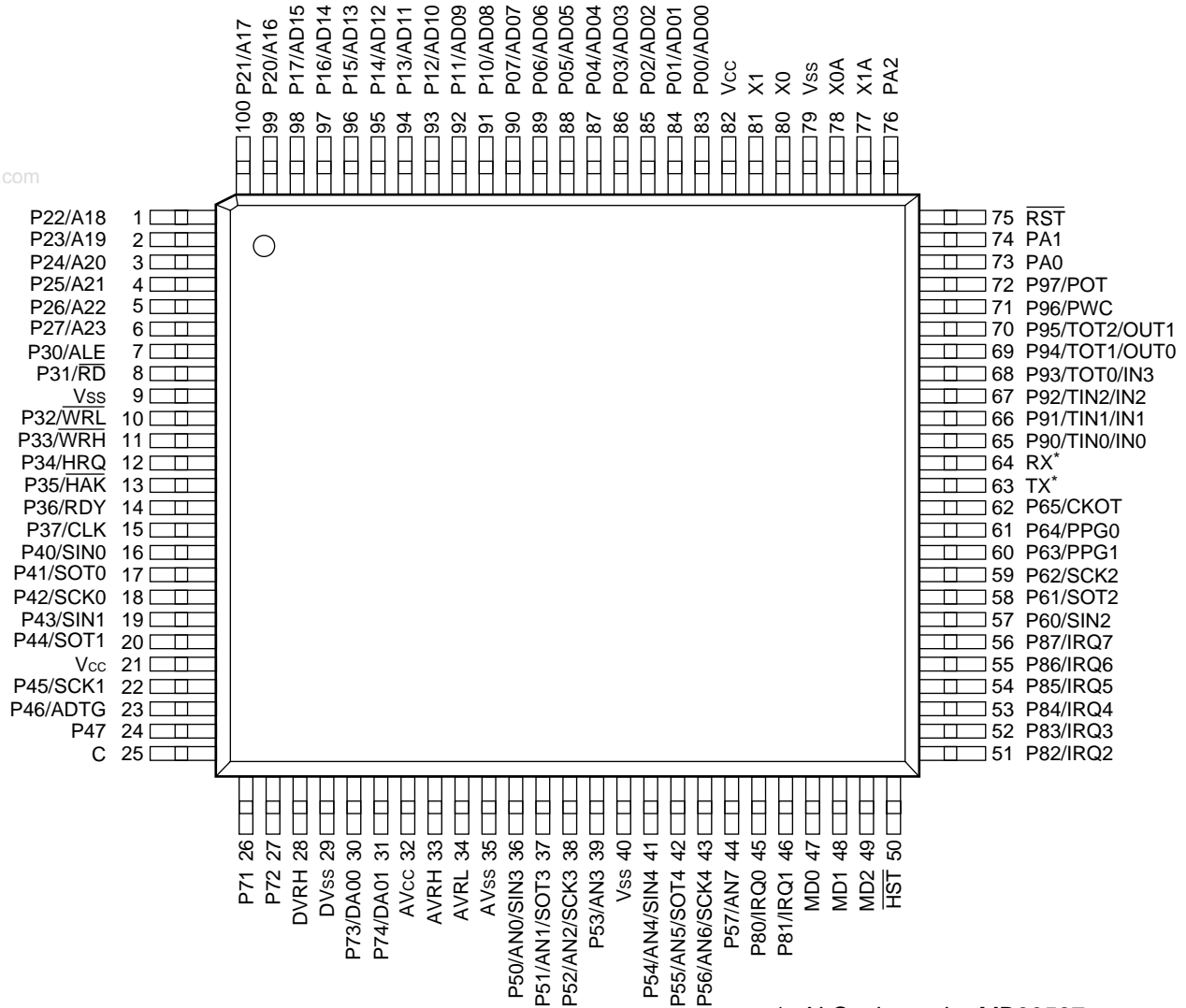

* : N.C. pin on the MB90587

(FPT-100P-M05)

MB90580B Series

(TOP VIEW)

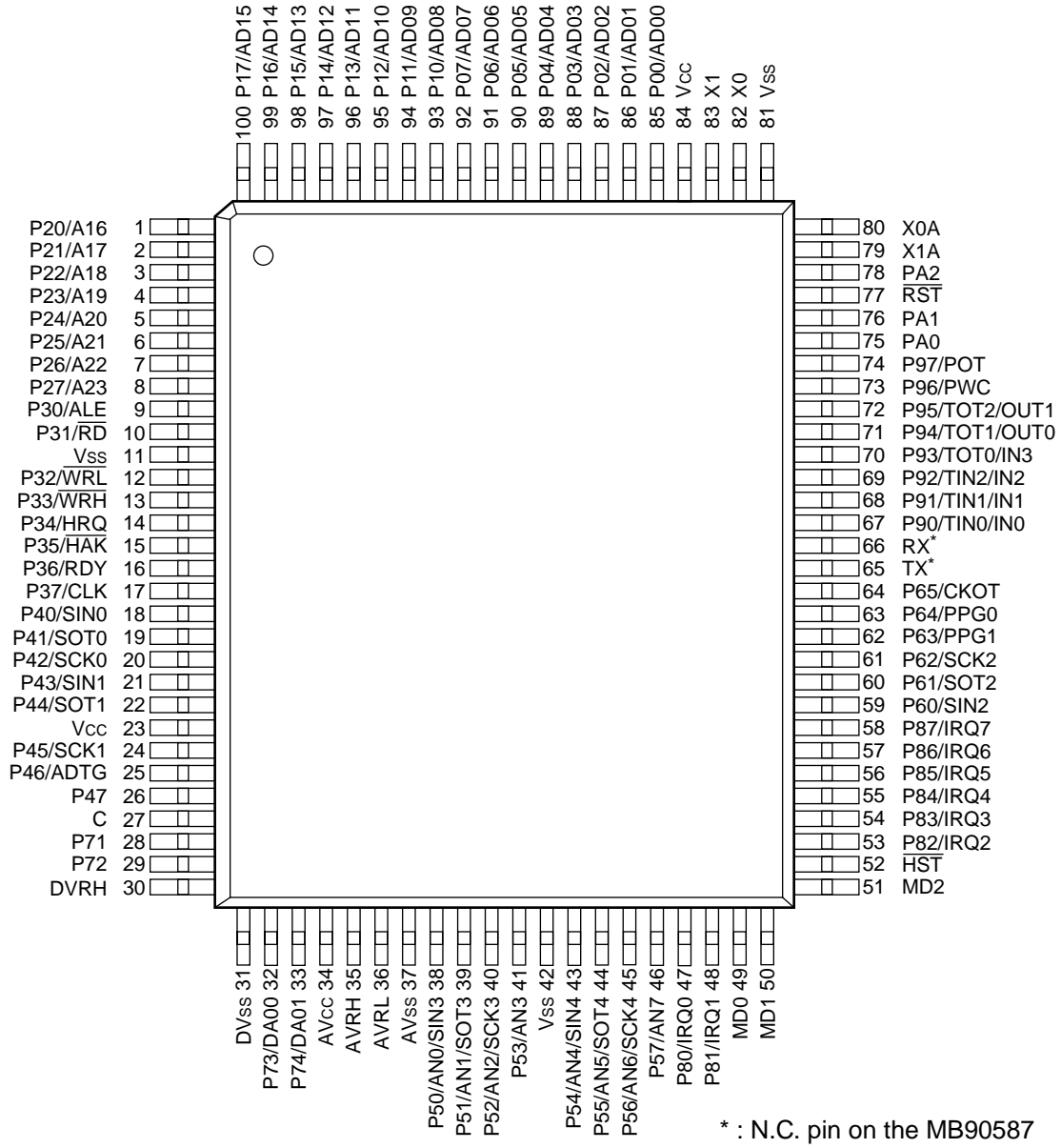

* : N.C. pin on the MB90587

(FPT-100P-M06)

■ PIN DESCRIPTION

Pin no.		Pin name	Circuit type	Function
QFP*1	LQFP*2			
82	80	X0	A	Oscillator pin
83	81	X1	A	Oscillator pin
52	50	$\overline{\text{HST}}$	C	Hardware standby input pin
77	75	$\overline{\text{RST}}$	B	Reset input pin
85 to 92	83 to 90	P00 to P07	D (CMOS/H)	General-purpose I/O ports. A pull-up resistor can be assigned (RD07 to RD00="1") by the pull-up resistor setting register (RDR0). [These pins are disabled with the output setting (DDR0 register: D07 to D00="1").]
		AD00 to AD07		In external bus mode, the pins function as the lower data I/O or lower address outputs (AD00 to AD07).
93 to 100	91 to 98	P10 to P17	F (CMOS/H)	General-purpose I/O ports. A pull-up resistor can be assigned (RD17 to RD10="1") by the pull-up resistor setting register (RDR1). [These pins are disabled with the output setting (DDR1 register: D17 to D10="1").]
		AD08 to AD15		In 16-bit external bus mode, the pins function as the upper data I/O or middle address outputs (AD08 to AD15).
1 to 8	99,100, 1 to 6	P20 to P27	F (CMOS/H)	General-purpose I/O ports In external bus mode, pins for which the corresponding bit in the HACR register is "1" function as the A16 to A23 pins.
		A16 to A23		In external bus mode, pins for which the corresponding bit in the HACR register is "1" function as the upper address output pins (A16 to A23).
9	7	P30	F (CMOS/H)	General-purpose I/O port Functions as the ALE pin in external bus mode.
		ALE		Functions as the address latch enable signal pin (ALE) in external bus mode.
10	8	P31	F (CMOS/H)	General-purpose I/O port Functions as the $\overline{\text{RD}}$ pin in external bus mode.
		$\overline{\text{RD}}$		Functions as the read strobe output pin ($\overline{\text{RD}}$) in external bus mode.
12	10	P32	F (CMOS/H)	General-purpose I/O port Functions as the $\overline{\text{WRL}}$ pin in external bus mode if the WRE bit is "1".
		$\overline{\text{WRL}}$		Functions as the lower data write strobe output pin ($\overline{\text{WRL}}$) in external bus mode.
13	11	P33	F (CMOS/H)	General-purpose I/O port Functions as the $\overline{\text{WRH}}$ pin in 16-bit external bus mode if the WRE bit in the EPCR register is "1"
		$\overline{\text{WRH}}$		Functions as the upper data write strobe output pin ($\overline{\text{WRH}}$) in external bus mode.

*1: FPT-100P-M06

*2: FPT-100P-M05

(Continued)

MB90580B Series

Pin no.		Pin name	Circuit type	Function
QFP*1	LQFP*2			
14	12	P34	F (CMOS/H)	General-purpose I/O port Functions as the HRQ pin in external bus mode if the HDE bit in the EPCR register is "1".
		HRQ		Functions as the hold request input pin (HRQ) in external bus mode.
15	13	P35	F (CMOS/H)	General-purpose I/O port Functions as the HAK pin in external bus mode if the HDE bit in the EPCR register is "1".
		$\overline{\text{HAK}}$		Functions as the hold acknowledge output pin ($\overline{\text{HAK}}$) in external bus mode.
16	14	P36	F (CMOS/H)	General-purpose I/O port Functions as the RDY pin in external bus mode if the RYE bit in the EPCR register is "1".
		RDY		Functions as the external ready input pin (RDY) in external bus mode.
17	15	P37	F (CMOS/H)	General-purpose I/O port Functions as the CLK pin in external bus mode if the CKE bit in the EPCR register is "1".
		CLK		Functions as the machine cycle clock output pin (CLK) in external bus mode.
18	16	P40	E (CMOS/H)	General-purpose I/O port. This pin serves as an open-drain output port with OD40 in the open-drain control setting register (ODR4) set to "1". [The pin is disabled with the input setting (DDR4 register: D40="0").]
		SIN0		UART0 serial data input (SIN0) pin. When UART0 is operating for input, this input is used as required and thus the output from any other function to the pin must be off unless used intentionally.
19	17	P41	E (CMOS/H)	General-purpose I/O port. This pin serves as an open-drain output port with OD41 in the open-drain control setting register (ODR4) set to "1". [The pin is disabled with the input setting (DDR4 register: D41="0").]
		SOT0		UART0 serial data output pin (SOT0). This pin is enabled with the UART0 serial data output enabled.
20	18	P42	E (CMOS/H)	General-purpose I/O port. This pin serves as an open-drain output port with OD42 in the open-drain control setting register (ODR4) set to "1". [The pin is disabled with the input setting (DDR4 register: D42="0").]
		SCK0		UART0 serial clock I/O pin (SCK0). This pin is enabled with the UART0 clock output enabled.

*1: FPT-100P-M06

*2: FPT-100P-M05

(Continued)

MB90580B Series

Pin no.		Pin name	Circuit type	Function
QFP*1	LQFP*2			
21	19	P43	E (CMOS/H)	General-purpose I/O port. This pin serves as an open-drain output port with OD43 in the open-drain control setting register (ODR4) set to "1". [The pin is disabled with the input setting (DDR4 register: D43="0").]
		SIN1		UART1 serial data input (SIN1) pin. When UART1 is operating for input, this input is used as required and thus the output from any other function to the pin must be off unless used intentionally.
22	20	P44	E (CMOS/H)	General-purpose I/O port. This pin serves as an open-drain output port with OD44 in the open-drain control setting register (ODR4) set to "1". [The pin is disabled with the input setting (DDR4 register: D44="0").]
		SOT1		UART1 serial data output pin (SOT1). This pin is enabled with the UART1 serial data output enabled.
24	22	P45	E (CMOS/H)	General-purpose I/O port. This pin serves as an open-drain output port with OD45 in the open-drain control setting register (ODR4) set to "1". [The pin is disabled with the input setting (DDR4 register: D45="0").]
		SCK1		UART1 serial clock I/O pin (SCK1). This pin is enabled with the UART1 clock output enabled.
25	23	P46	E (CMOS/H)	General-purpose I/O port. This pin serves as an open-drain output port with OD46 in the open-drain control setting register (ODR4) set to "1". [The pin is disabled with the input setting (DDR4 register: D46="0").]
		ADTG		External trigger input pin (ADTG) for the A/D converter.
26	24	P47	E (CMOS/H)	General-purpose I/O port. This pin serves as an open-drain output port with OD47 in the open-drain control setting register (ODR4) set to "1". [The pin is disabled with the input setting (DDR4 register: D47="0").]
38	36	P50	G (CMOS/H)	General-purpose I/O port.
		AN0		Analog input pin (AN0) for use during A/D converter operation.
		SIN3		UART3 serial data input pin (SIN3). When UART3 is operating for input, this input is used as required and thus the output from any other function to the pin must be off unless used intentionally.
39	37	P51	G (CMOS/H)	General-purpose I/O port.
		AN1		Analog input pin (AN1) for use during A/D converter operation.
		SOT3		UART3 serial data output pin (SOT3). This pin is enabled with the UART3 serial data output enabled.

*1: FPT-100P-M06

*2: FPT-100P-M05

(Continued)

MB90580B Series

Pin no.		Pin name	Circuit type	Function
QFP*1	LQFP*2			
40	38	P52	G (CMOS/H)	General-purpose I/O port.
		AN2		Analog input pin (AN2) for use during A/D converter operation.
		SCK3		UART3 serial clock I/O pin (SCK3). This pin is enabled with the UART3 clock output enabled.
41	39	P53	G (CMOS/H)	General-purpose I/O port.
		AN3		Analog input pin (AN3) for use during A/D converter operation.
43	41	P54	G (CMOS/H)	General-purpose I/O port.
		AN4		Analog input pin (AN4) for use during A/D converter operation.
		SIN4		UART4 serial data input pin (SIN4). When UART4 is operating for input, this input is used as required and thus the output from any other function to the pin must be off unless used intentionally.
44	42	P55	G (CMOS/H)	General-purpose I/O port.
		AN5		Analog input pin (AN5) for use during A/D converter operation.
		SOT4		UART4 serial data output pin (SOT4). This pin is enabled with the UART4 serial data output enabled.
45	43	P56	G (CMOS/H)	General-purpose I/O port.
		AN6		Analog input pin (AN6) for use during A/D converter operation.
		SCK4		UART4 serial clock output pin (SCK4). This pin is enabled with the UART4 clock output enabled.
46	44	P57	G (CMOS/H)	General-purpose I/O port.
		AN7		Analog input pin (AN7) for use during A/D converter operation.
27	25	C	—	0.1 μ F capacitor coupling pin for regulating the power supply.
28	26	P71	F (CMOS/H)	General-purpose I/O port.
29	27	P72	F (CMOS/H)	General-purpose I/O port.
32	30	P73	H (CMOS/H)	General-purpose I/O port. This pin serves as a D/A output pin (DA00) when the DAE0 bit in the D/A control register (DACR) is "1".
		DA00		D/A converter output 0 (DA00) pin.
33	31	P74	H (CMOS/H)	General-purpose I/O port. This pin serves as a D/A output pin (DA01) when the DAE1 bit in the D/A control register (DACR) is "1".
		DA01		D/A converter output 1 pin (DA01).
47	45	P80	F (CMOS/H)	General-purpose I/O port.
		IRQ0		Functions as external interrupt request input 0 pin (IRQ0).

*1: FPT-100P-M06

*2: FPT-100P-M05

(Continued)

MB90580B Series

Pin no.		Pin name	Circuit type	Function
QFP*1	LQFP*2			
48	46	P81	F (CMOS/H)	General-purpose I/O port.
		IRQ1		Functions as external interrupt request input 1 pin (IRQ1).
53	51	P82	F (CMOS/H)	General-purpose I/O port.
		IRQ2		Functions as external interrupt request input 2 pin (IRQ2).
54	52	P83	F (CMOS/H)	General-purpose I/O port.
		IRQ3		Functions as external interrupt request input 3 pin (IRQ3).
55	53	P84	F (CMOS/H)	General-purpose I/O port.
		IRQ4		Functions as external interrupt request input 4 pin (IRQ4).
56	54	P85	F (CMOS/H)	General-purpose I/O port.
		IRQ5		Functions as external interrupt request input 5 pin (IRQ5).
57	55	P86	F (CMOS/H)	General-purpose I/O port.
		IRQ6		Functions as external interrupt request input 6 pin (IRQ6).
58	56	P87	F (CMOS/H)	General-purpose I/O port.
		IRQ7		Functions as external interrupt request input 7 pin (IRQ7).
59	57	P60	D (CMOS/H)	General-purpose I/O port. A pull-up resistor can be assigned (RD60="1") by the pull-up resistor setting register (RDR6). [This pin is disabled with the output setting (DDR6 register: D60="1").]
		SIN2		UART2 serial data input pin (SIN2). When UART2 is operating for input, this input is used as required and thus the output from any other function to the pin must be off unless used intentionally.
60	58	P61	D (CMOS/H)	General-purpose I/O port. A pull-up resistor can be assigned (RD61="1") by the pull-up resistor setting register (RDR6). [This pin is disabled with the output setting (DDR6 register: D61="1").]
		SOT2		UART2 serial data output pin (SOT2). This pin is enabled with the UART2 serial data output enabled.
61	59	P62	D (CMOS/H)	General-purpose I/O port. A pull-up resistor can be assigned (RD62="1") by the pull-up resistor setting register (RDR6). [This pin is disabled with the output setting (DDR6 register: D62="1").]
		SCK2		UART2 serial clock I/O pin (SCK2). This pin is enabled with the UART2 clock output enabled.

*1: FPT-100P-M06

*2: FPT-100P-M05

(Continued)

MB90580B Series

(Continued)

Pin no.		Pin name	Circuit type	Function
QFP*1	LQFP*2			
62	60	P63	D (CMOS/H)	General-purpose I/O port. A pull-up resistor can be assigned (RD63="1") by the pull-up resistor setting register (RDR6). [This pin is disabled with the output setting (DDR6 register: D63="1").]
		PPG1		The pin serves as the PPG1 output when PPGs are enabled.
63	61	P64	D (CMOS/H)	General-purpose I/O port. A pull-up resistor can be assigned (RD64="1") by the pull-up resistor setting register (RDR6). [This pin is disabled with the output setting (DDR6 register: D64="1").]
		PPG0		The pin serves as the PPG0 output when PPGs are enabled.
64	62	P65	D (CMOS/H)	General-purpose I/O port. A pull-up resistor can be assigned (RD65="1") by the pull-up resistor setting register (RDR6). [This pin is disabled with the output setting (DDR6 register: D65="1").]
		CKOT		This pin serves as the CKOT output during CKOT operation.
65	63	TX*3	I	This pin serves as the IEBus™ output.
66	64	RX*3	J (CMOS)	This pin serves as the IEBus™ input.
67 to 69	65 to 67	P90 to P92	F (CMOS/H)	General-purpose I/O port.
		TIN0 to TIN2		Event input pins for reload timers 0, 1, and 2. During reload timer input, these inputs are used continuously and thus the output from any other function to the pins must be avoided unless used intentionally.
		IN0 to IN2		Trigger inputs for input capture channels 0 to 2
70	68	P93	F (CMOS/H)	General-purpose I/O port.
		TOT0		Reload timer output pin. This function is applied when the output for reload timer 0 is enabled.
		IN3		Trigger inputs for input capture channel 3.
71, 72	69, 70	P94, P95	F (CMOS/H)	General-purpose I/O port.
		TOT1, TOT2		Reload timer output pins. This function is applied when the output for reload timer 1 and 2 are enabled.
		OUT0, OUT1		Event output for channel 0 and 1 of the output compare
73	71	P96	F (CMOS/H)	General-purpose I/O port.
		PWC		This pin serves as the PWC input with the PWC timer enabled.

*1: FPT-100P-M06

*2: FPT-100P-M05

*3: N.C. pin on the MB90587.

(Continued)

MB90580B Series

(Continued)

Pin no.		Pin name	Circuit type	Function
QFP*1	LQFP*2			
74	72	P97	F (CMOS/H)	General-purpose I/O port.
		POT		This pin serves as the PWC output with the PWC timer enabled.
75, 76	73, 74	PA0, PA1	F (CMOS/H)	General-purpose I/O port.
78	76	PA2	F (CMOS/H)	General-purpose I/O port.
79	77	X1A	A	Oscillation input pin.
80	78	X0A	A	Oscillation input pin.
34	32	AV _{CC}	—	A/D converter power supply pin.
37	35	AV _{SS}	—	A/D converter power supply pin.
35	33	AVRH	—	A/D converter external reference power supply pin.
36	34	AVRL	—	A/D converter external reference power supply pin.
30	28	DVRH	—	D/A converter external reference power supply pin.
31	29	DV _{SS}	—	D/A converter power supply pin.
49 to 51	47 to 49	MD0 to MD2	C	Input pin for specifying the operation mode. Connect these pins directly to V _{CC} or V _{SS} .
23, 84	21, 82	V _{CC}	—	Power supply (5 V) input pin.
11, 42, 81	9, 40, 79	V _{SS}	—	Power supply (0 V) input pin.

*1: FPT-100P-M06

*2: FPT-100P-M05

MB90580B Series

I/O CIRCUIT TYPE

Type	Circuit	Remarks
A	<p>X1, X1A</p> <p>X0, X0A</p> <p>HARD, SOFT STANDBY CONTROL</p> <p>Clock input</p>	<ul style="list-style-type: none"> Oscillation feedback resistance : Approx. 1 MΩ
B		<ul style="list-style-type: none"> Hysteresis input with pull-up Resistance approx. 50 kΩ
C		<ul style="list-style-type: none"> Hysteresis input
D	<p>Pull-up resistor control</p> <p>Standby control signal</p>	<ul style="list-style-type: none"> Incorporates pull-up resistor control (for input) CMOS level output Hysteresis input with standby control Resistance approx. 50 kΩ

(Continued)

MB90580B Series

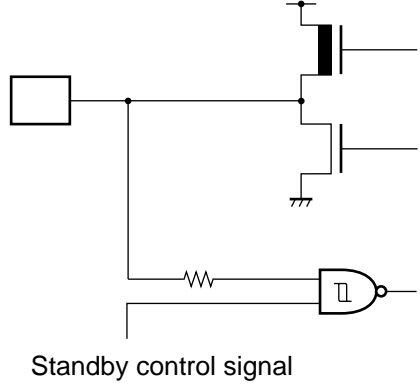
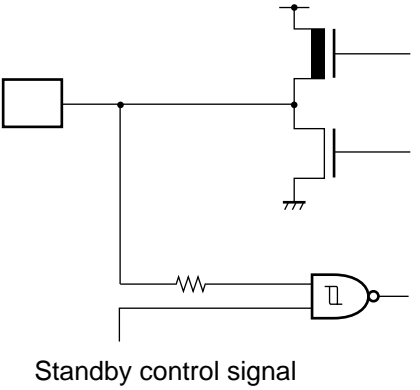
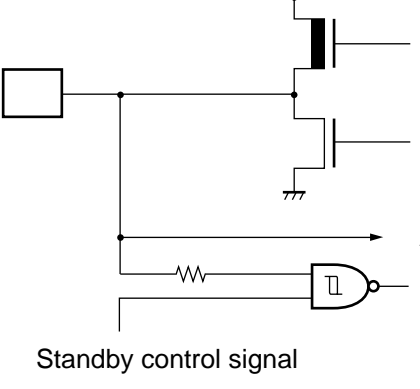
Type	Circuit	Remarks
E	 <p>Open-drain control signal</p> <p>Standby control signal</p>	<ul style="list-style-type: none"> • CMOS level output • Hysteresis input with standby control • Incorporates open-drain control
F	 <p>Standby control signal</p>	<ul style="list-style-type: none"> • CMOS level output • Hysteresis input with standby control
G	 <p>Analog input</p> <p>Standby control signal</p>	<ul style="list-style-type: none"> • CMOS level output • Hysteresis input with standby control • Analog input

(Continued)

MB90580B Series

(Continued)

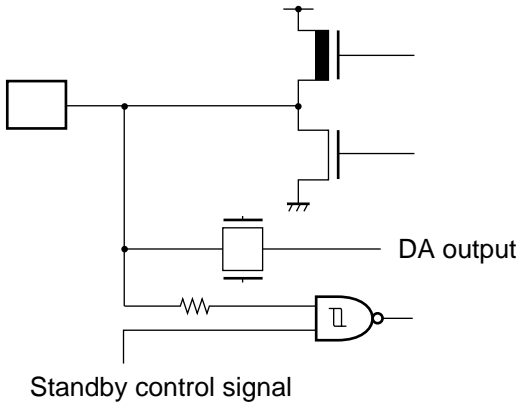
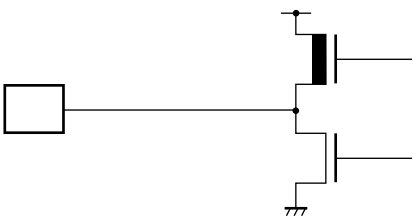
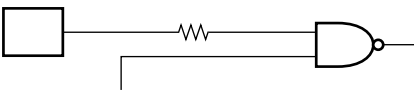
Type	Circuit	Remarks
H	 <p>Standby control signal</p> <p>DA output</p>	<ul style="list-style-type: none"> • CMOS level output • Hysteresis input with standby control • DA output
I		<ul style="list-style-type: none"> • CMOS level output
J	 <p>Standby control signal</p>	<ul style="list-style-type: none"> • CMOS input with standby control

■ HANDLING DEVICES

1. Preventing Latchup

CMOS ICs may cause latchup in the following situations:

- When a voltage higher than V_{CC} or lower than V_{SS} is applied to input or output pins.
- When a voltage exceeding the rating is applied between V_{CC} and V_{SS} .
- When AV_{CC} power is supplied prior to the V_{CC} voltage.

If latchup occurs, the power supply current increases rapidly, sometimes resulting in thermal breakdown of the device. Use meticulous care not to let it occur.

For the same reason, also be careful not to let the analog power-supply voltage exceed the digital power-supply voltage.

2. Handling unused input pins

Unused input pins left open may cause abnormal operation, or latch-up leading to permanent damage. Unused input pins should be pulled up or pulled down through at least 2 k Ω resistance.

Unused input/output pins may be left open in output state, but if such pins are in input state they should be handled in the same way as input pins.

3. Treatment of the TX and RX pins with the IEBus™ unused

When the IEBus is not used, connect a pull-down resistor to the TX pin and a pull-down/pull-up resistor to the RX pin.

4. Use of the subclock mode and external clock

Even when the subclock mode is not used, connect an oscillator to the X0A or X1A pin.

When the device uses an external clock, drive only the X0 pin while leaving the X1 pin open (See the illustration below).

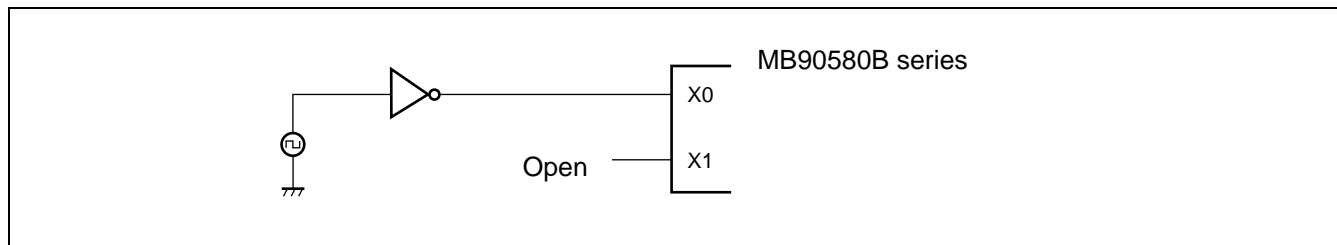

5. Power Supply Pins (V_{CC}/V_{SS})

In products with multiple V_{CC} or V_{SS} pins, the pins of a same potential are internally connected in the device to avoid abnormal operations including latch-up. However, connect the pins external power and ground lines to lower the electro-magnetic emission level to prevent abnormal operation of strobe signals caused by the rise in the ground level, and to conform to the total current rating.

Make sure to connect V_{CC} and V_{SS} pins via lowest impedance to power lines.

MB90580B Series

It is recommended to provide a bypass capacitor of around 0.1 μF between V_{CC} and V_{SS} pin near the device.

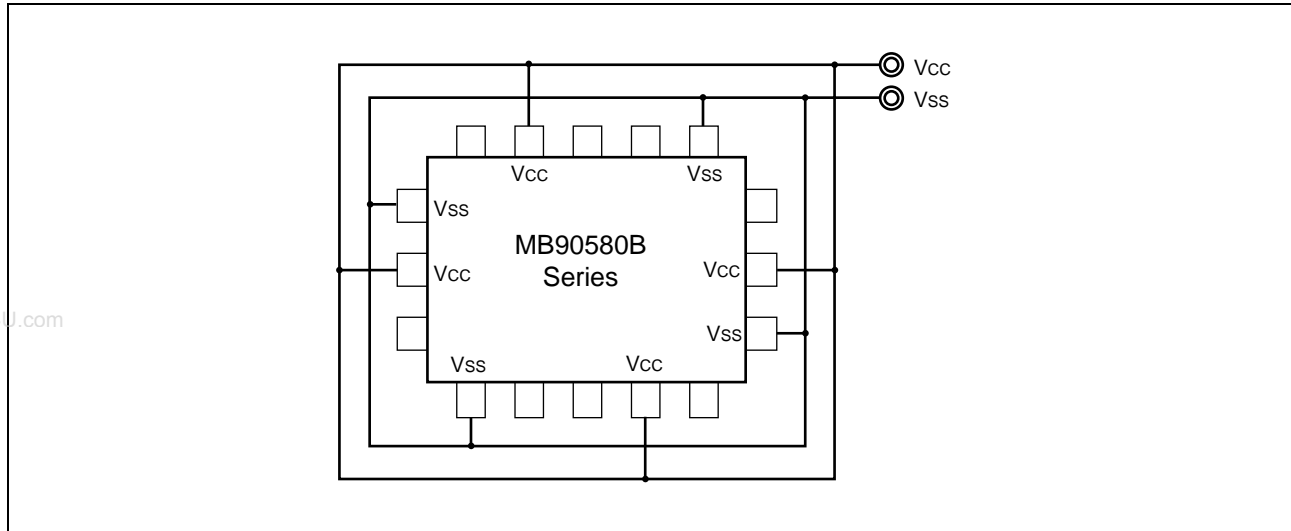

6. Crystal Oscillator Circuit

Noises around X0 or X1 pins may be possible causes of abnormal operations. Make sure to provide bypass capacitors via shortest distance from X0, X1 pins, crystal oscillator (or ceramic resonator) and ground lines, and make sure, to the utmost effort, that lines of oscillation circuit not cross the lines of other circuits.

It is highly recommended to provide a printed circuit board art work surrounding X0 and X1 pins with an grand area for stabilizing the operation.

7. Turning-on Sequence of Power Supply to A/D Converter and Analog Inputs

Make sure to turn on the A/D converter power supply (AV_{CC} , AV_{SS} , AV_{RH} , AV_{RL}) and analog inputs (AN0 to AN7) after turning-on the digital power supply (V_{CC}).

Turn-off the digital power after turning off the A/D converter supply and analog inputs. In this case, make sure that the voltage of AV_{RH} dose not exceed AV_{CC} (turning on/off the analog and digital power supplies simulta-
neously is acceptable).

8. Connection of Unused Pins of A/D Converter

Connect unused pin of A/D converter to $AV_{\text{CC}} = V_{\text{CC}}$, $AV_{\text{SS}} = AV_{\text{RH}} = AV_{\text{RL}} = V_{\text{SS}}$.

9. Connection of Unused Pins of D/A Converter

Connect unused pin of D/A converter to $DV_{\text{RH}} = V_{\text{SS}}$, $DV_{\text{SS}} = V_{\text{SS}}$.

10. N.C. Pin

The N.C. (internally connected) pin must be opened for use.

11. Notes on Energization

To prevent the internal regulator circuit from malfunctioning, set the voltage rise time during energization at 50 μs or more (0.2 V to 2.7 V).

12. Indeterminate outputs from ports 0 and 1

The outputs from ports 0 and 1 become indeterminate during a power-on reset after the power is turned on. Pay attention to the port output timing shown as follow.

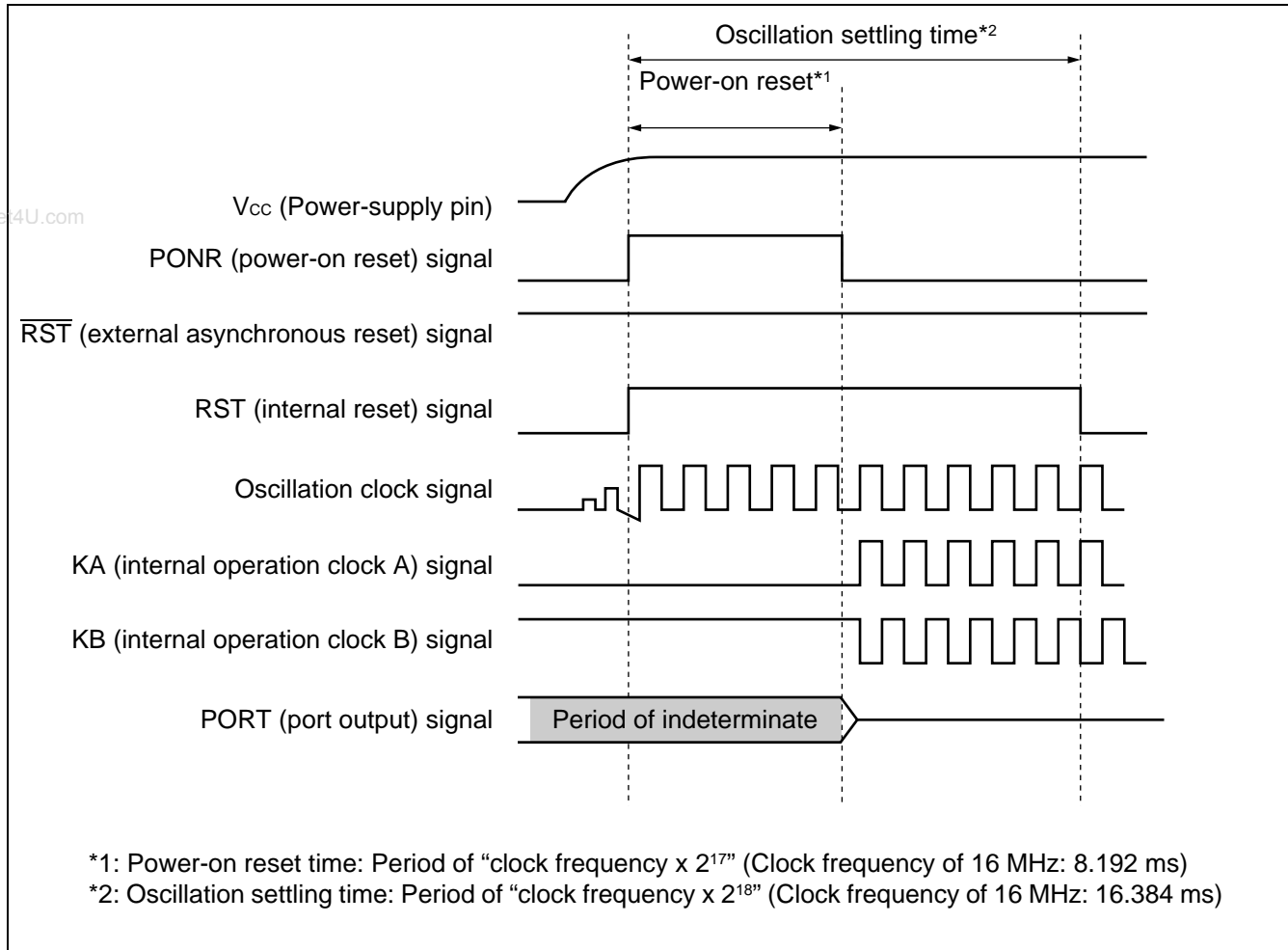

13. Initialization

In the device, there are internal registers which are initialized only by a power-on reset. To initialize these registers turning on the power again.

14. Return from standby state

If the power-supply voltage goes below the standby RAM holding voltage in the standby state, the device may fail to return from the standby state. In this case, reset the device via the external reset pin to return to the normal state.

15. Precautions for Use of 'DIV A, Ri,' and 'DIVW A, RWi' Instructions

The signed multiplication-division instructions 'DIV A, Ri,' and 'DIVW A, RWi' should be used when the corresponding bank registers (DTB, ADB, USB, SSB) are set to value '00h.' If the corresponding bank registers (DTB, ADB, USB, SSB) are set to a value other than '00h,' then the remainder obtained after the execution of the instruction will not be placed in the instruction operand register.

16. Precautions for Use of REALOS

Extended intelligent I/O service (EI²OS) cannot be used, when REALOS is used.

MB90580B Series

■ BLOCK DIAGRAM

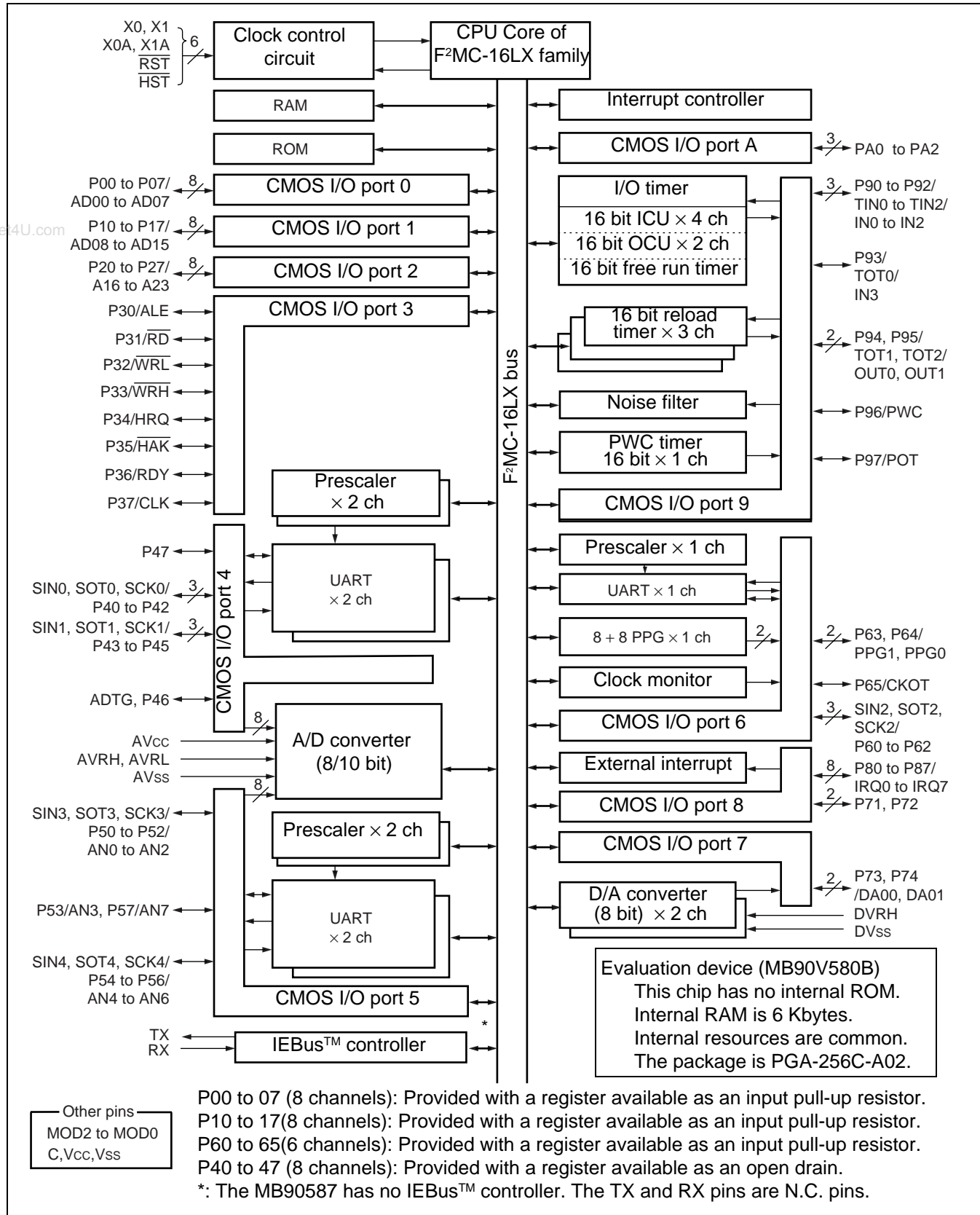

MEMORY MAP

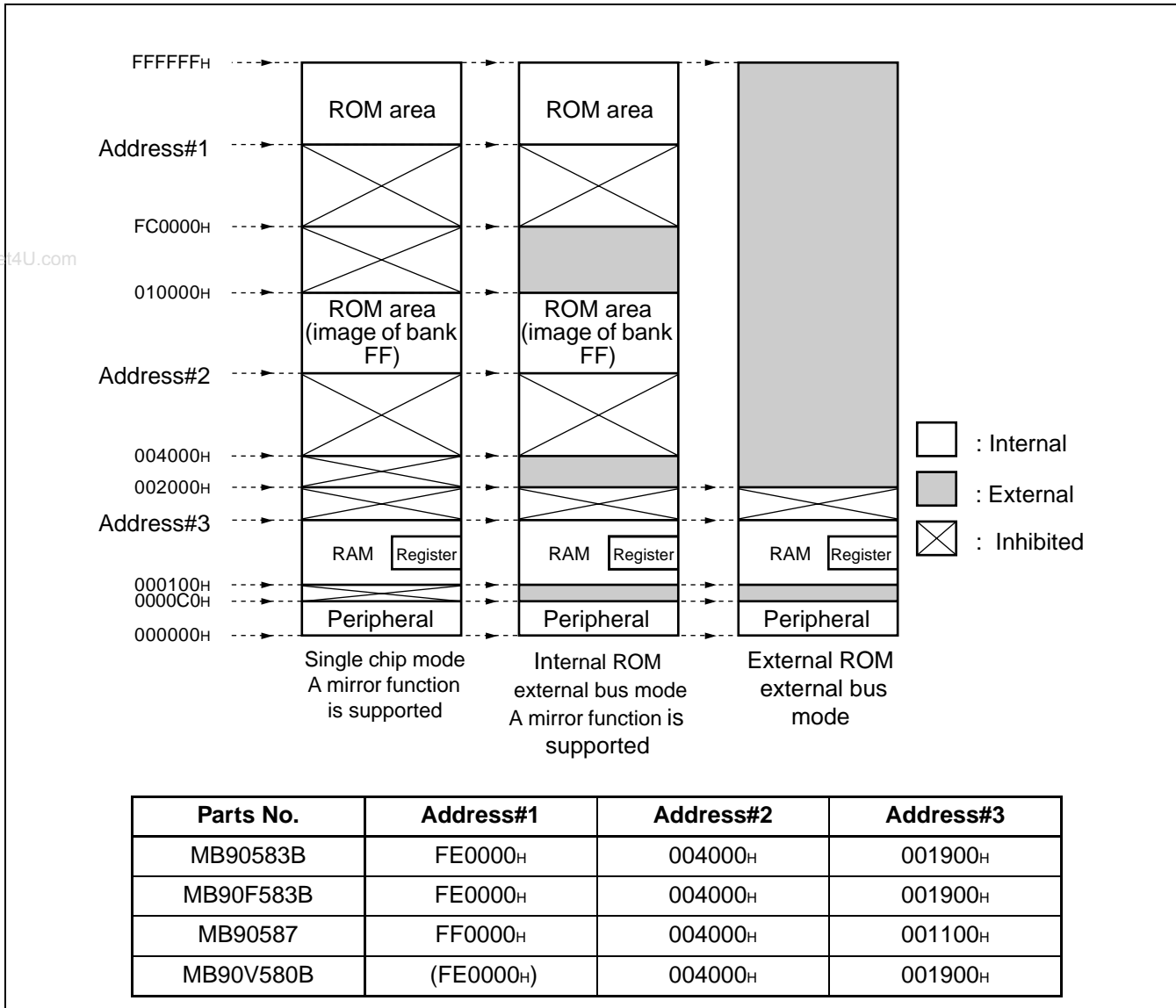

Note: The ROM data of bank FF is reflected in the upper address of bank 00, realizing effective use of the C compiler small model. The lower 16-bit is assigned to the same address, enabling reference of the table on the ROM without stating "far". For example, if an attempt has been made to access 00C000_H, the contents of the ROM at FFC000_H are accessed actually. Since the ROM area of the FF bank exceeds 48 Kbytes, the whole area cannot be reflected in the image for the 00 bank. The ROM data at FF4000_H to FFFFFFF_H looks, therefore, as if it were the image for 004000_H to 00FFFF_H. Thus, it is recommended that the ROM data table be stored in the area of FF4000_H to FFFFFFF_H.

MB90580B Series

■ F²MC-16LX CPU PROGRAMMING MODEL

- Dedicated registers

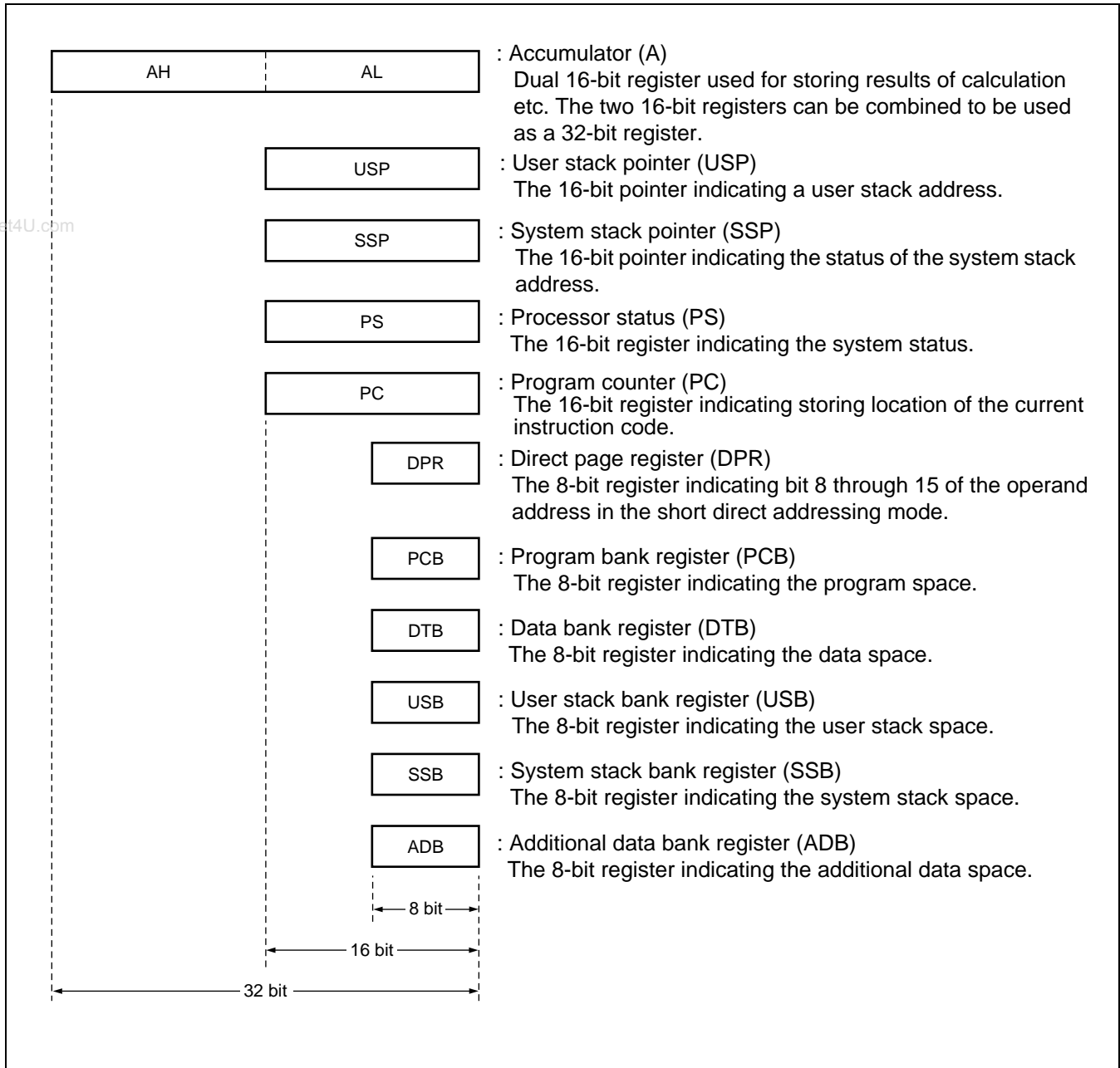

• General-purpose registers

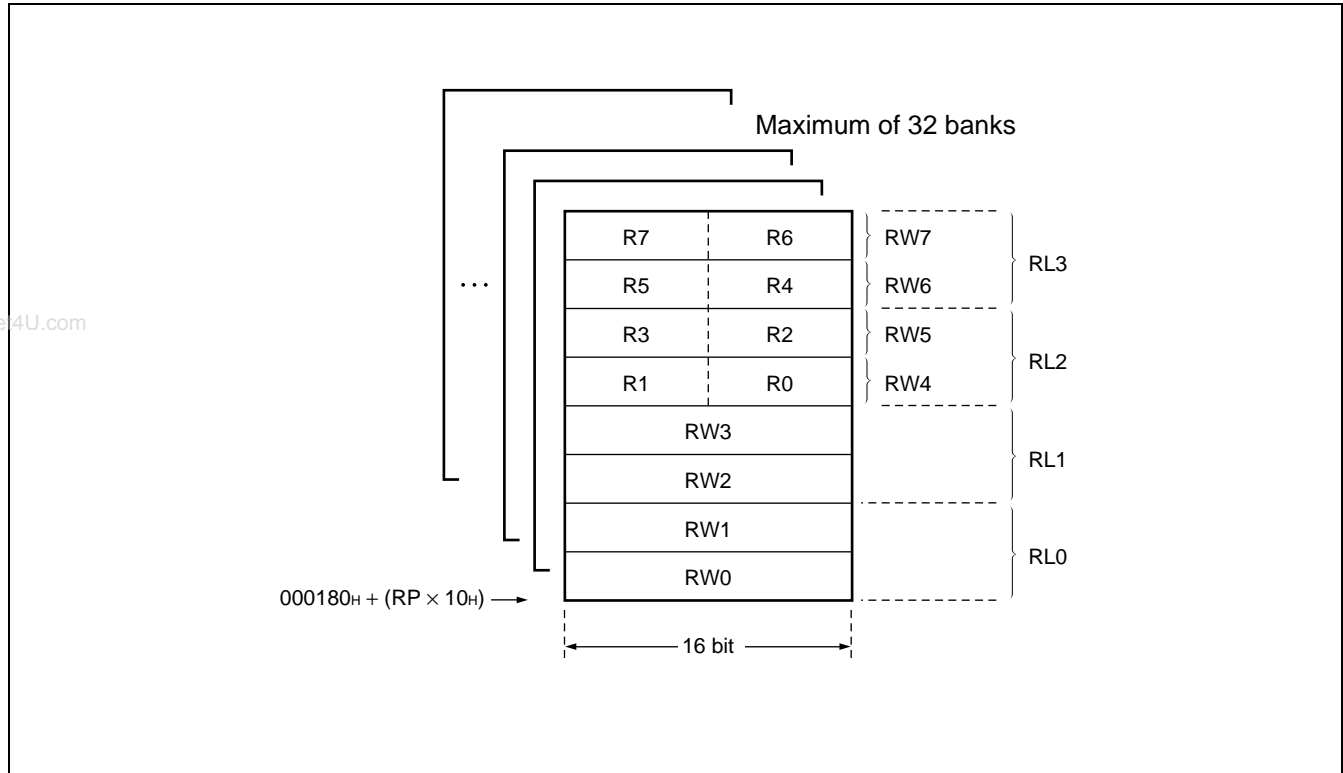

• Processor status (PS)

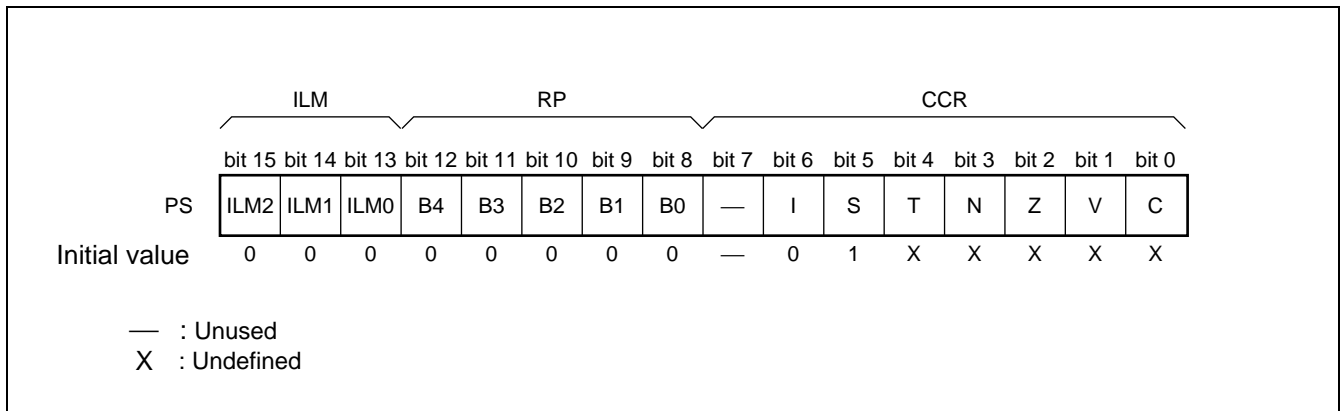

MB90580B Series

■ I/O MAP

Address	Register name	Abbreviated register name	Read/write	Resource name	Initial value
00 _H	Port 0 data register	PDR0	R/W	Port 0	XXXXXXXX _B
01 _H	Port 1 data register	PDR1	R/W	Port 1	XXXXXXXX _B
02 _H	Port 2 data register	PDR2	R/W	Port 2	XXXXXXXX _B
03 _H	Port 3 data register	PDR3	R/W	Port 3	XXXXXXXX _B
04 _H	Port 4 data register	PDR4	R/W	Port 4	XXXXXXXX _B
05 _H	Port 5 data register	PDR5	R/W	Port 5	11111111 _B
06 _H	Port 6 data register	PDR6	R/W	Port 6	XXXXXXXX _B
07 _H	Port 7 data register	PDR7	R/W	Port 7	---XXXX- _B
08 _H	Port 8 data register	PDR8	R/W	Port 8	XXXXXXXX _B
09 _H	Port 9 data register	PDR9	R/W	Port 9	XXXXXXXX _B
0A _H	Port A data register	PDRA	R/W	Port A	-----XXX _B
0B _H to 0F _H	(Disabled)				
10 _H	Port 0 direction register	DDR0	R/W	Port 0	00000000 _B
11 _H	Port 1 direction register	DDR1	R/W	Port 1	00000000 _B
12 _H	Port 2 direction register	DDR2	R/W	Port 2	00000000 _B
13 _H	Port 3 direction register	DDR3	R/W	Port 3	00000000 _B
14 _H	Port 4 direction register	DDR4	R/W	Port 4	00000000 _B
15 _H	Port 5 direction register	DDR5	R/W	Port 5	00000000 _B
16 _H	Port 6 direction register	DDR6	R/W	Port 6	00000000 _B
17 _H	Port 7 direction register	DDR7	R/W	Port 7	---0000- _B
18 _H	Port 8 direction register	DDR8	R/W	Port 8	00000000 _B
19 _H	Port 9 direction register	DDR9	R/W	Port 9	00000000 _B
1A _H	Port A direction register	DDRA	R/W	Port A	-----000 _B
1B _H	Port 4 output pin register	ODR4	R/W	Port 4	00000000 _B
1C _H	Port 5 analog input enable register	ADER	R/W	Port 4, A/D	11111111 _B
1D _H to 1F _H	(Disabled)				
20 _H	Serial mode register 0	SMR0	R/W	UART0	00000000 _B
21 _H	Serial control register 0	SCR0	R/W		00000100 _B
22 _H	Serial input data register 0/ serial output data register 0	SIDR0/ SODR0	R/W		XXXXXXXX _B
23 _H	Serial status register 0	SSR0	R/W		00001-00 _B

(Continued)

MB90580B Series

Address	Register name	Abbreviated register name	Read/write	Resource name	Initial value
24H	Serial mode register 1	SMR1	R/W	UART1	00000000 _B
25H	Serial control register 1	SCR1	R/W		00000100 _B
26H	Serial input data register 1/ serial output data register 1	SIDR1/ SODR1	R/W		XXXXXXXX _B
27H	Serial status register 1	SSR1	R/W		00001-00 _B
28H	Serial mode register 2	SMR2	R/W	UART2	00000000 _B
29H	Serial control register 2	SCR2	R/W		00000100 _B
2AH	Serial input data register 2/ serial output data register 2	SIDR2/ SODR2	R/W		XXXXXXXX _B
2BH	Serial status register 2	SSR2	R/W		00001-00 _B
2CH	Clock division control register 0	CDCR0	R/W	Communications prescaler 0	0---1111 _B
2DH	(Disabled)				
2EH	Clock division control register 1	CDCR1	R/W	Communications prescaler 1	0---1111 _B
2FH	(Disabled)				
30H	DTP/interrupt enable register	ENIR	R/W	DTP/external interrupt	00000000 _B
31H	DTP/interrupt factor register	EIRR	R/W		XXXXXXXX _B
32H	Request level setting register lower	ELVR	R/W		00000000 _B
33H	Request level setting register upper				00000000 _B
34H	Clock division control register 2	CDCR2	R/W	Communications prescaler 2	0---1111 _B
35H	(Disabled)				
36H	Control status register lower	ADCS1	R/W	A/D converter	00000000 _B
37H	Control status register upper	ADCS2	R/W		00000000 _B
38H	Data register lower	ADCR1	R		XXXXXXXX _B
39H	Data register upper	ADCR2	R or W		00001-XX _B
3AH	D/A converter data register 0	DAT0	R/W	D/A converter	00000000 _B
3BH	D/A converter data register 1	DAT1	R/W		00000000 _B
3CH	D/A control register 0	DACR0	R/W		-----0 _B
3DH	D/A control register 1	DACR1	R/W		-----0 _B
3EH	Clock output enable register	CLKR	R/W	Clock monitor function	----0000 _B
3FH	(Disabled)				

(Continued)

MB90580B Series

Address	Register name	Abbreviated register name	Read/write	Resource name	Initial value
40H	Reload register L (ch.0)	PRLLO	R/W	8/16 bit PPG0/1	XXXXXXXX _B
41H	Reload register H (ch.0)	PRLHO	R/W		XXXXXXXX _B
42H	Reload register L (ch.1)	PRLLO	R/W		XXXXXXXX _B
43H	Reload register H (ch.1)	PRLHO	R/W		XXXXXXXX _B
44H	PPG0 operating mode control register	PPGC0	R/W		0X000XX1 _B
45H	PPG1 operating mode control register	PPGC1	R/W		0X000001 _B
46H	PPG0 and 1 operating output control registers	PPGOE	R/W		00000000 _B
47H	(Disabled)				
48H	Timer control status register lower	TMCSR0	R/W	16 bit reload timer 0	00000000 _B
49H	Timer control status register upper				----0000 _B
4AH	16 bit timer register lower/ 16 bit reload register lower	TMR0/ TMRLR0	R/W		XXXXXXXX _B
4BH	16 bit timer register upper/ 16 bit reload register upper				XXXXXXXX _B
4CH	Timer control status register lower	TMCSR1	R/W	16 bit reload timer 1	00000000 _B
4DH	Timer control status register upper				----0000 _B
4EH	16bit timer register lower/ 16 bit reload register lower	TMR1/ TMRLR1	R/W		XXXXXXXX _B
4FH	16 bit timer register upper/ 16 bit reload register upper				XXXXXXXX _B
50H	Timer control status register lower	TMCSR2	R/W	16 bit reload timer 2	00000000 _B
51H	Timer control status register upper				----0000 _B
52H	16 bit timer register lower/ 16 bit reload register lower	TMR2/ TMRLR2	R/W		XXXXXXXX _B
53H	16 bit timer register upper/ 16 bit reload register upper				XXXXXXXX _B
54H	PWC control status register lower	PWCSR	R/W	16 bit PWC timer	00000000 _B
55H	PWC control status register upper				00000000 _B
56H	PWC data buffer register lower	PWCR	R/W		XXXXXXXX _B
57H	PWC data buffer register upper				XXXXXXXX _B
58H	Divide ratio control register	DIVR	R/W	-----00 _B	
59H	(Disabled)				

(Continued)

MB90580B Series

Address	Register name	Abbreviated register name	Read/write	Resource name	Initial value
5A _H	Compare register lower	OCCP0	R/W	Output compare (ch.0)	XXXXXXXX _B
5B _H	Compare register upper				XXXXXXXX _B
5C _H	Compare register lower	OCCP1	R/W	Output compare (ch.1)	XXXXXXXX _B
5D _H	Compare register upper				XXXXXXXX _B
5E _H	Compare control status register 0	OCS0	R/W	Output compare (ch.0)	0000--00 _B
5F _H	Compare control status register 1	OCS1	R/W	Output compare (ch.1)	---0000 _B
60 _H	Input capture register lower	IPCP0	R	Input capture (ch.0)	XXXXXXXX _B
61 _H	Input capture register upper				XXXXXXXX _B
62 _H	Input capture register lower	IPCP1	R	Input capture (ch.1)	XXXXXXXX _B
63 _H	Input capture register upper				XXXXXXXX _B
64 _H	Input capture register lower	IPCP2	R	Input capture (ch.2)	XXXXXXXX _B
65 _H	Input capture register upper				XXXXXXXX _B
66 _H	Input capture register lower	IPCP3	R	Input capture (ch.3)	XXXXXXXX _B
67 _H	Input capture register upper				XXXXXXXX _B
68 _H	Input capture control status register 01	ICS01	R/W	Input capture (ch.0, ch.1)	0000000 _B
69 _H	(Disabled)				
6A _H	Input capture control status register 23	ICS23	R/W	Input capture (ch.2, ch.3)	0000000 _B
6B _H	(Disabled)				
6C _H	Timer data register lower	TCDTL	R/W	Free-run timer	0000000 _B
6D _H	Timer data register upper	TCDTH	R/W		0000000 _B
6E _H	Timer control status register	TCCS	R/W		0000000 _B
6F _H	ROM mirroring function selection register	ROMM	W	ROM mirror function	-----1 _B
70 _H	Local-office address setting register L	MAWL	R/W	IEBus™ controller	XXXXXXXX _B
71 _H	Local-office address setting register H	MAWH	R/W		XXXXXXXX _B
72 _H	Slave address setting register L	SAWL	R/W		XXXXXXXX _B
73 _H	Slave address setting register H	SAWH	R/W		XXXXXXXX _B
74 _H	Message length bit setting register	DEWR	R/W		0000000 _B
75 _H	Broadcast control bit setting register	DCWR	R/W		0000000 _B

(Continued)

MB90580B Series

Address	Register name	Abbreviated register name	Read/write	Resource name	Initial value
76 _H	Command register L	CMRL	R/W	IEBus™ controller	11000000 _B
77 _H	Command register H	CMRH	R/W		0000000X _B
78 _H	Status register L	STRL	R		0011XXXX _B
79 _H	Status register H	STRH	R/W		00XX0000 _B
7A _H	Lock read register L	LRRL	R		XXXXXXXX _B
7B _H	Lock read register H	LRRH	R/W or R		1110XXXX _B
7C _H	Master address read register L	MARL	R		XXXXXXXX _B
7D _H	Master address read register H	MARH	R		1111XXXX _B
7E _H	Message length bit read register	DERR	R		XXXXXXXX _B
7F _H	Broadcast control bit read register	DCRR	R		000XXXXX _B
80 _H	Write data buffer	WDB	W		XXXXXXXX _B
81 _H	Read data buffer	RDB	R		XXXXXXXX _B
82 _H	Serial mode register 3	SMR3	R/W		UART3
83 _H	Serial control register 3	SCR3	R/W	00000100 _B	
84 _H	Serial input register 3/ serial output register 3	SIDR3/ SODR3	R/W	XXXXXXXX _B	
85 _H	Serial status register 3	SSR3	R/W	00001-00 _B	
86 _H	PWC noise filter register	RNCR	R/W	PWC noisefilter	-----000 _B
87 _H	Clock division control register 3	CDCR3	R/W	Communications prescaler 3	0---1111 _B
88 _H	Serial mode register 4	SMR4	R/W	UART4	00000000 _B
89 _H	Serial control register 4	SCR4	R/W		00000100 _B
8A _H	Serial input register 4/ serial output register 4	SIDR4/ SODR4	R/W		XXXXXXXX _B
8B _H	Serial status register 4	SSR4	R/W		00001-00 _B
8C _H	Port 0 input pull-up resistor setup register	RDR0	R/W	Port 0	00000000 _B
8D _H	Port 1 input pull-up resistor setup register	RDR1	R/W	Port 1	00000000 _B
8E _H	Port 6 input pull-up resistor setup register	RDR6	R/W	Port 2	00000000 _B
8F _H	Clock division control register 4	CDCR4	R/W	Communications prescaler 4	0---1111 _B
90 _H to 9D _H	(Disabled)				

(Continued)

MB90580B Series

Address	Register name	Abbreviated register name	Read/write	Resource name	Initial value
9E _H	Program address detection control/status register	PACSR	R/W	Address match detection function	00000000 _B
9F _H	Delayed interrupt generation/release register	DIRR	R/W	Delayed interrupt generation module	-----0 _B
A0 _H	Low-power consumption mode control register	LPMCR	R/W or W	Low-power consumption mode	0001100- _B
A1 _H	Clock selection register	CKSCR	R/W or R		11111100 _B
A2 _H to A4 _H	(Disabled)				
A5 _H	Auto-ready function selection register	ARSR	W	External bus pin control circuit	0011--00 _B
A6 _H	External address output control register	HACR	W		00000000 _B
A7 _H	Bus control signal selection register	ECSR	W		0000000- _B
A8 _H	Watch dog timer control register	WDTC	R or W	Watch dog timer	XXXXX111 _B
A9 _H	Time-base timer control register	TBTC	R/W, W	Timebase timer	1--00100 _B
AA _H	Clock timer control register	WTC	R/W	Clock timer	1X000000 _B
AB _H to AD _H	(Disabled)				
AE _H	Flash memory control status register	FMCS	R/W, R or W	Flash interface	000X0000 _B
AF _H	(Disabled)				
B0 _H	Interrupt control register 00	ICR00	R/W	Interrupt controller	00000111 _B
B1 _H	Interrupt control register 01	ICR01	R/W		00000111 _B
B2 _H	Interrupt control register 02	ICR02	R/W		00000111 _B
B3 _H	Interrupt control register 03	ICR03	R/W		00000111 _B
B4 _H	Interrupt control register 04	ICR04	R/W		00000111 _B
B5 _H	Interrupt control register 05	ICR05	R/W		00000111 _B
B6 _H	Interrupt control register 06	ICR06	R/W		00000111 _B
B7 _H	Interrupt control register 07	ICR07	R/W		00000111 _B
B8 _H	Interrupt control register 08	ICR08	R/W		00000111 _B
B9 _H	Interrupt control register 09	ICR09	R/W		00000111 _B
BA _H	Interrupt control register 10	ICR10	R/W		00000111 _B
BB _H	Interrupt control register 11	ICR11	R/W		00000111 _B
BC _H	Interrupt control register 12	ICR12	R/W		00000111 _B
BD _H	Interrupt control register 13	ICR13	R/W		00000111 _B
BE _H	Interrupt control register 14	ICR14	R/W		00000111 _B
BF _H	Interrupt control register 15	ICR15	R/W		00000111 _B

MB90580B Series

(Continued)

(Continued)

Address	Register name	Abbreviated register name	Read/write	Resource name	Initial value
C0 _H to FF _H	(External area)				
100 _H to # _H	(RAM area)				
# _H to 1FEF _H	(Reserved area)				
1FF0 _H	Program address detection register 0 (lower)	PADR0	R/W	Address match detection function	XXXXXXXX _B
1FF1 _H	Program address detection register 1 (middle)		R/W		XXXXXXXX _B
1FF2 _H	Program address detection register 2 (upper)		R/W		XXXXXXXX _B
1FF3 _H	Program address detection register 3 (lower)	PADR1	R/W		XXXXXXXX _B
1FF4 _H	Program address detection register 4 (middle)		R/W		XXXXXXXX _B
1FF5 _H	Program address detection register 5 (upper)		R/W		XXXXXXXX _B
1FF6 _H to 1FFF _H	(Reserved area)				

- Explanation of initial values→“0” : initial value“0” / “1” : initial value“1” / “X” : undefined / “-” : undefined (not used)
- The addresses following 00FF_H are reserved. No external bus access signal is generated.
- Boundary #_H between the RAM area and the reserved area varies with the product model.

Note: For bits that is initialized by a reset operation, the initial value set by the reset operation is listed as an initial value. Note that the values are different from reading results. For LPMCR/CKSCR/WDTC, there are cases where initialization is performed or not performed, depending on the types of the reset. However initial value for resets that initializes the value are listed.

■ INTERRUPT FACTORS, INTERRUPT VECTORS, INTERRUPT CONTROL REGISTER

Interrupt source	EI ² OS support	Interrupt vector		Interrupt control register		Priority
		No.	Address	ICR	Address	
Reset	×	#08	FFFFDC _H	—	—	High ↑
INT9 instruction	×	#09	FFFFD8 _H	—	—	
Exception	×	#10	FFFFD4 _H	—	—	
A/D converter	○	#11	FFFFD0 _H	ICR00	0000B0 _H	↓ Low
Timebase timer	×	#12	FFFFCC _H			
DTP0 (external interrupt #0) /UART3 reception complete	○	#13	FFFFC8 _H	ICR01	0000B1 _H	
DTP1 (external interrupt #1) /UART4 reception complete	○	#14	FFFFC4 _H			
DTP2 (external interrupt #2) /UART3 transmission complete	○	#15	FFFFC0 _H	ICR02	0000B2 _H	
DTP3 (external interrupt #3) /UART4 transmission complete	○	#16	FFFFBC _H			
DTP4 to 7 (external interrupt #4 to #7)	○	#17	FFFFB8 _H	ICR03	0000B3 _H	
Output compare (ch.1) match (I/O timer)	○	#18	FFFFB4 _H			
UART2 reception complete	○	#19	FFFFB0 _H	ICR04	0000B4 _H	
UART1 reception complete	○	#20	FFFFAC _H			
Input capture (ch.3) include (I/O timer)	○	#21	FFFFA8 _H	ICR05	0000B5 _H	
Input capture (ch.2) include (I/O timer)	○	#22	FFFFA4 _H			
Input capture (ch.1) include (I/O timer)	○	#23	FFFFA0 _H	ICR06	0000B6 _H	
Input capture (ch.0) include (I/O timer)	○	#24	FFFF9C _H			
8/16 bit PPG0 counter borrow	×	#25	FFFF98 _H	ICR07	0000B7 _H	
16 bit reload timer 2 to 0	○	#26	FFFF94 _H			
Clock prescaler	×	#27	FFFF90 _H	ICR08	0000B8 _H	
Output compare (ch.0) match (I/O timer)	○	#28	FFFF8C _H			
UART2 transmission complete	○	#29	FFFF88 _H	ICR09	0000B9 _H	
PWC timer measurement complete / over flow	○	#30	FFFF84 _H			
UART1 transmission complete	○	#31	FFFF80 _H	ICR10	0000BA _H	
16-bit free run timer (I/O timer) over flow	○	#32	FFFF7C _H			
UART0 transmission complete	○	#33	FFFF78 _H	ICR11	0000BB _H	
8/16 bit PPG1 counter borrow	×	#34	FFFF74 _H			
IEBus reception complete	⊙	#35	FFFF70 _H	ICR12	0000BC _H	
IEBus transmission start	⊙	#37	FFFF68 _H	ICR13	0000BD _H	
UART0 reception complete	⊙	#39	FFFF60 _H	ICR14	0000BE _H	
Flash memory status	×	#41	FFFF58 _H	ICR15	0000BF _H	
Delayed interrupt	×	#42	FFFF54 _H			

⊙ : Indicates that the interrupt request flag is cleared by the EI²OS interrupt clear signal (stop request present).

○ : Indicates that the interrupt request flag is cleared by the EI²OS interrupt clear signal.

×

MB90580B Series

PERIPHERAL RESOURCES

1. I/O Ports

(1) Outline of I/O ports

When a data register serving for control output is read, the data output from it as a control output is read regardless of the value in the direction register. Note that, if a read modify write instruction (such as a bit set instruction) is used to preset output data in the data register when changing its setting from input to output, the data read is not the data register latched value but the input data from the pin.

Ports 0 to 4 and 6 to A are input/output ports which serve as inputs when the direction register value is "0" or as outputs when the value is "1".

On the MB90580B series, ports 0 to 3 also serve as external bus pins. When the device is used in external bus mode, therefore, these ports are restricted on use.

Ports 2 and 3 can be used as ports even in external bus mode depending on the setting of the corresponding function select bit.

(2) Register configuration

- Port 0 data register (PDR0)

bit	15	8	7	6	5	4	3	2	1	0
Address	: 000000H										
	(PDR1)			P07	P06	P05	P04	P03	P02	P01	P00
Access				(R/W)	(R/W)	(R/W)	(R/W)	(R/W)	(R/W)	(R/W)	(R/W)
Initial value				(X)	(X)	(X)	(X)	(X)	(X)	(X)	(X)

- Port 1 data register (PDR1)

bit	15	14	13	12	11	10	9	8	7	0
Address	: 000001H										
	P17	P16	P15	P14	P13	P12	P11	P10	(PDR0)		
Access	(R/W)	(R/W)	(R/W)	(R/W)	(R/W)	(R/W)	(R/W)	(R/W)			
Initial value	(X)	(X)	(X)	(X)	(X)	(X)	(X)	(X)			

- Port 2 data register (PDR2)

bit	15	8	7	6	5	4	3	2	1	0
Address	: 000002H										
	(PDR3)			P27	P26	P25	P24	P23	P22	P21	P20
Access				(R/W)	(R/W)	(R/W)	(R/W)	(R/W)	(R/W)	(R/W)	(R/W)
Initial value				(X)	(X)	(X)	(X)	(X)	(X)	(X)	(X)

- Port 3 data register (PDR3)

bit	15	14	13	12	11	10	9	8	7	0
Address	: 000003H										
	P37	P36	P35	P34	P33	P32	P31	P30	(PDR2)		
Access	(R/W)	(R/W)	(R/W)	(R/W)	(R/W)	(R/W)	(R/W)	(R/W)			
Initial value	(X)	(X)	(X)	(X)	(X)	(X)	(X)	(X)			

- Port 4 data register (PDR4)

bit	15	8	7	6	5	4	3	2	1	0
Address	: 000004H										
	(PDR5)			P47	P46	P45	P44	P43	P42	P41	P40
Access				(R/W)	(R/W)	(R/W)	(R/W)	(R/W)	(R/W)	(R/W)	(R/W)
Initial value				(X)	(X)	(X)	(X)	(X)	(X)	(X)	(X)

(Continued)

(Continued)

• Port 5 data register (PDR5)

bit	15	14	13	12	11	10	9	8	7	0
Address : 000005H	P57	P56	P55	P54	P53	P52	P51	P50	(PDR4)		
Access	(R/8)	(R/W)	(R/W)	(R/W)	(R/W)	(R/W)	(R/W)	(R/W)			
Initial value	(1)	(1)	(1)	(1)	(1)	(1)	(1)	(1)			

• Port 6 data register (PDR6)

bit	15	8	7	6	5	4	3	2	1	0
Address : 000006H	(PDR7)			P67	P66	P65	P64	P63	P62	P61	P60
Access				(R/W)	(R/W)	(R/W)	(R/W)	(R/W)	(R/W)	(R/W)	(R/W)
Initial value				(X)	(X)	(X)	(X)	(X)	(X)	(X)	(X)

• Port 7 data register (PDR7)

bit	15	14	13	12	11	10	9	8	7	0
Address : 000007H	—	—	—	P74	P73	P72	P71	—	(PDR6)		
Access	(—)	(—)	(—)	(R/W)	(R/W)	(R/W)	(R/W)	(—)			
Initial value	(—)	(—)	(—)	(X)	(X)	(X)	(X)	(—)			

• Port 8 data register (PDR8)

bit	15	8	7	6	5	4	3	2	1	0
Address : 000008H	(PDR9)			P87	P86	P85	P84	P83	P82	P81	P80
Access				(R/W)	(R/W)	(R/W)	(R/W)	(R/W)	(R/W)	(R/W)	(R/W)
Initial value				(X)	(X)	(X)	(X)	(X)	(X)	(X)	(X)

• Port 9 data register (PDR9)

bit	15	14	13	12	11	10	9	8	7	0
Address : 000009H	P97	P96	P95	P94	P93	P92	P91	P90	(PDR8)		
Access	(R/W)	(R/W)	(R/W)	(R/W)	(R/W)	(R/W)	(R/W)	(R/W)			
Initial value	(X)	(X)	(X)	(X)	(X)	(X)	(X)	(X)			

• Port A data register (PDRA)

bit	15	8	7	6	5	4	3	2	1	0
Address : 00000AH	(Disabled)			—	—	—	—	—	PA2	PA1	PA0
Access				(—)	(—)	(—)	(—)	(—)	(R/W)	(R/W)	(R/W)
Initial value				(—)	(—)	(—)	(—)	(—)	(X)	(X)	(X)

• Port 0 direction register (DDR0)

bit	15	8	7	6	5	4	3	2	1	0
Address : 000010H	(DDR1)			D07	D06	D05	D04	D03	D02	D01	D00
Access				(R/W)	(R/W)	(R/W)	(R/W)	(R/W)	(R/W)	(R/W)	(R/W)
Initial value				(0)	(0)	(0)	(0)	(0)	(0)	(0)	(0)

(Continued)

MB90580B Series

(Continued)

• Port 1 direction register (DDR1)

bit	15	14	13	12	11	10	9	8	7	0
Address : 000011H	D17	D16	D15	D14	D13	D12	D11	D10	(DDR0)		
Access	(R/W)	(R/W)	(R/W)	(R/W)	(R/W)	(R/W)	(R/W)	(R/W)			
Initial value	(0)	(0)	(0)	(0)	(0)	(0)	(0)	(0)			

• Port 2 direction register (DDR2)

bit	15	8	7	6	5	4	3	2	1	0
Address : 000012H	(DDR3)			D27	D26	D25	D24	D23	D22	D21	D20
Access				(R/W)	(R/W)	(R/W)	(R/W)	(R/W)	(R/W)	(R/W)	(R/W)
Initial value				(0)	(0)	(0)	(0)	(0)	(0)	(0)	(0)

• Port 3 direction register (DDR3)

bit	15	14	13	12	11	10	9	8	7	0
Address : 000013H	D37	P36	P35	P34	P33	P32	P31	P30	(DDR2)		
Access	(R/W)	(R/W)	(R/W)	(R/W)	(R/W)	(R/W)	(R/W)	(R/W)			
Initial value	(0)	(0)	(0)	(0)	(0)	(0)	(0)	(0)			

• Port 4 direction register (DDR4)

bit	15	8	7	6	5	4	3	2	1	0
Address : 000014H	(DDR5)			D47	D46	D45	D44	D43	D42	D41	D40
Access				(R/W)	(R/W)	(R/W)	(R/W)	(R/W)	(R/W)	(R/W)	(R/W)
Initial value				(0)	(0)	(0)	(0)	(0)	(0)	(0)	(0)

• Port 5 direction register (DDR5)

bit	15	14	13	12	11	10	9	8	7	0
Address : 000015H	D57	D56	D55	D54	D53	D52	D51	D50	(DDR4)		
Access	(R/W)	(R/W)	(R/W)	(R/W)	(R/W)	(R/W)	(R/W)	(R/W)			
Initial value	(0)	(0)	(0)	(0)	(0)	(0)	(0)	(0)			

• Port 6 direction register (DDR6)

bit	15	8	7	6	5	4	3	2	1	0
Address : 000016H	(DDR7)			D67	D66	D65	D64	D63	D62	D61	D60
Access				(R/W)	(R/W)	(R/W)	(R/W)	(R/W)	(R/W)	(R/W)	(R/W)
Initial value				(0)	(0)	(0)	(0)	(0)	(0)	(0)	(0)

• Port 7 direction register (DDR7)

bit	15	14	13	12	11	10	9	8	7	0
Address : 000017H	—	—	—	D74	D73	D72	D71	—	(DDR6)		
Access	(—)	(—)	(—)	(R/W)	(R/W)	(R/W)	(R/W)	(—)			
Initial value	(—)	(—)	(—)	(0)	(0)	(0)	(0)	(—)			

(Continued)

MB90580B Series

- Port 8 direction register (DDR8)

bit	15	14	13	12	11	10	9	8	7	6	5	4	3	2	1	0
Address : 000018H	(DDR9)								D87	D86	D85	D84	D83	D82	D81	D80
Access									(R/W)	(R/W)	(R/W)	(R/W)	(R/W)	(R/W)	(R/W)	(R/W)
Initial value									(0)	(0)	(0)	(0)	(0)	(0)	(0)	(0)

- Port 9 direction register (DDR9)

bit	15	14	13	12	11	10	9	8	7	6	5	4	3	2	1	0
Address : 000019H	D97	D96	D95	D94	D93	D92	D91	D90	(DDR8)							
Access	(R/W)	(R/W)	(R/W)	(R/W)	(R/W)	(R/W)	(R/W)	(R/W)								
Initial value	(0)	(0)	(0)	(0)	(0)	(0)	(0)	(0)								

- Port A direction register (DDRA)

bit	15	14	13	12	11	10	9	8	7	6	5	4	3	2	1	0
Address : 00001AH	(ODR4)								—	—	—	—	—	DA2	DA1	DA0
Access									(—)	(—)	(—)	(—)	(—)	(R/W)	(R/W)	(R/W)
Initial value									(—)	(—)	(—)	(—)	(—)	(0)	(0)	(0)

- Port 4 output pin register (ODR4)

bit	15	14	13	12	11	10	9	8	7	6	5	4	3	2	1	0
Address : 00001BH	OD47	OD46	OD45	OD44	OD43	OD42	OD41	OD40	(DDRA)							
Access	(R/W)	(R/W)	(R/W)	(R/W)	(R/W)	(R/W)	(R/W)	(R/W)								
Initial value	(0)	(0)	(0)	(0)	(0)	(0)	(0)	(0)								

- Port 5 analog input enable register (ADER)

bit	15	14	13	12	11	10	9	8	7	6	5	4	3	2	1	0
Address : 00001CH	(ADER)								ADE7	ADE6	ADE5	ADE4	ADE3	ADE2	ADE1	ADE0
Access									(R/W)	(R/W)	(R/W)	(R/W)	(R/W)	(R/W)	(R/W)	(R/W)
Initial value									(1)	(1)	(1)	(1)	(1)	(1)	(1)	(1)

- Port 0 input pull-up resistor setup register (RDR0)

bit	15	14	13	12	11	10	9	8	7	6	5	4	3	2	1	0
Address : 00008CH	(RDR1)								RD07	RD06	RD05	RD04	RD03	RD02	RD01	RD00
Access									(R/W)	(R/W)	(R/W)	(R/W)	(R/W)	(R/W)	(R/W)	(R/W)
Initial value									(0)	(0)	(0)	(0)	(0)	(0)	(0)	(0)

- Port 1 input pull-up resistor setup register (RDR1)

bit	15	14	13	12	11	10	9	8	7	6	5	4	3	2	1	0
Address : 00008DH	RD17	RD16	RD15	RD14	RD13	RD12	RD11	RD10	(RDR0)							
Access	(R/W)	(R/W)	(R/W)	(R/W)	(R/W)	(R/W)	(R/W)	(R/W)								
Initial value	(0)	(0)	(0)	(0)	(0)	(0)	(0)	(0)								

- Port 6 input pull-up resistor setup register (RDR6)

bit	15	14	13	12	11	10	9	8	7	6	5	4	3	2	1	0
Address : 00008EH	(CDCR4)								RD67	RD66	RD65	RD64	RD63	RD62	RD61	RD60
Access									(R/W)	(R/W)	(R/W)	(R/W)	(R/W)	(R/W)	(R/W)	(R/W)
Initial value									(0)	(0)	(0)	(0)	(0)	(0)	(0)	(0)

MB90580B Series

(3) Block Diagram

• Input/output port

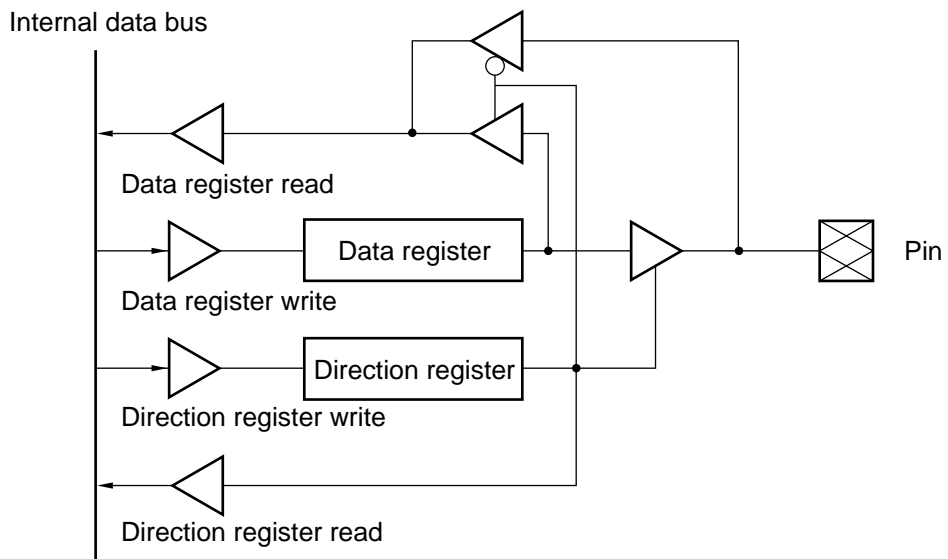

• Input pull-up resistor setup register

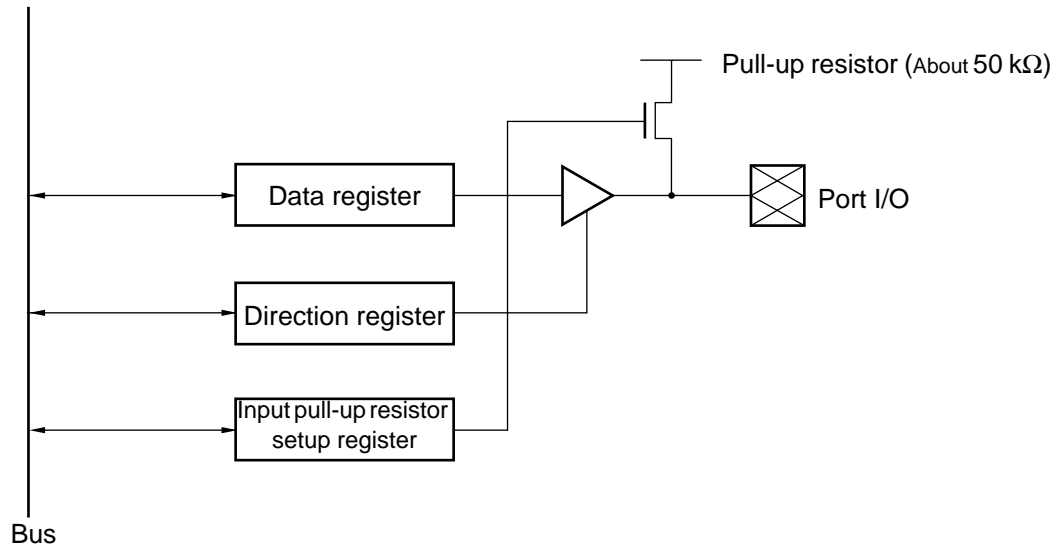

• Output pin register

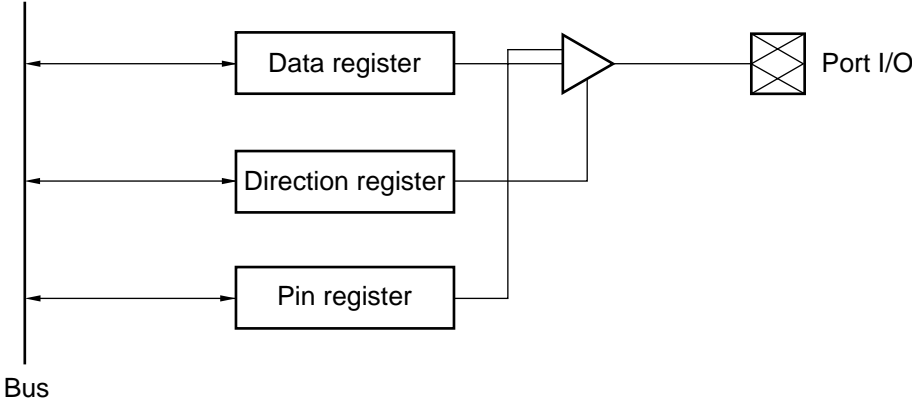

MB90580B Series

2. Timebase Timer

The time-base timer consists of a 18-bit timer and an interval interrupt control circuit. Note that the time-base timer uses the oscillation clock regardless of the setting of the MCS bit in the CKSCR.

(1) Register configuration

- Timebase timer control register

bit	15	14	13	12	11	10	9	8	...	TBTC
Address	: 0000A9H									
Access	(R/W)	(—)	(—)	(R/W)	(R/W)	(W)	(R/W)	(R/W)	...	
Initial value	(1)	(—)	(—)	(0)	(0)	(1)	(0)	(0)	...	

(2) Block Diagram

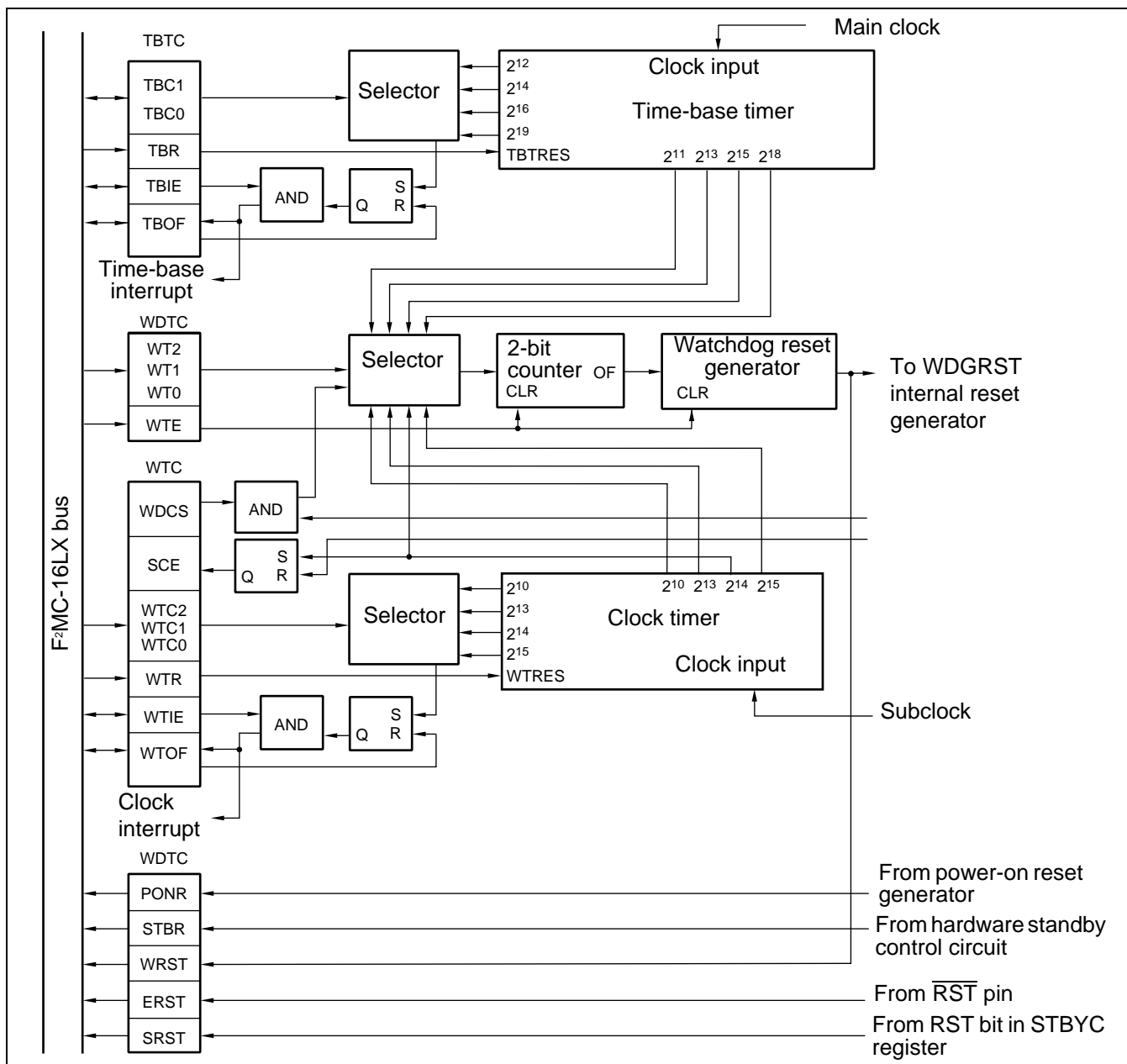

3. Watchdog Timer

The watchdog timer consists of a 2-bit watchdog counter using carry signals from the 18-bit time-base timer as the clock source, a control register, and a watchdog reset control section.

(1) Register configuration

- Watchdog timer control register

Address	bit 7	bit 6	bit 5	bit 4	bit 3	bit 2	bit 1	bit 0	
: 0000A8 _H	PONR	STBR	WRST	ERST	SRST	WTE	WT1	WT0	WDTC
Access	(R)	(R)	(R)	(R)	(R)	(W)	(W)	(W)	
Initial value	(X)	(X)	(X)	(X)	(X)	(1)	(1)	(1)	

(2) Block Diagram

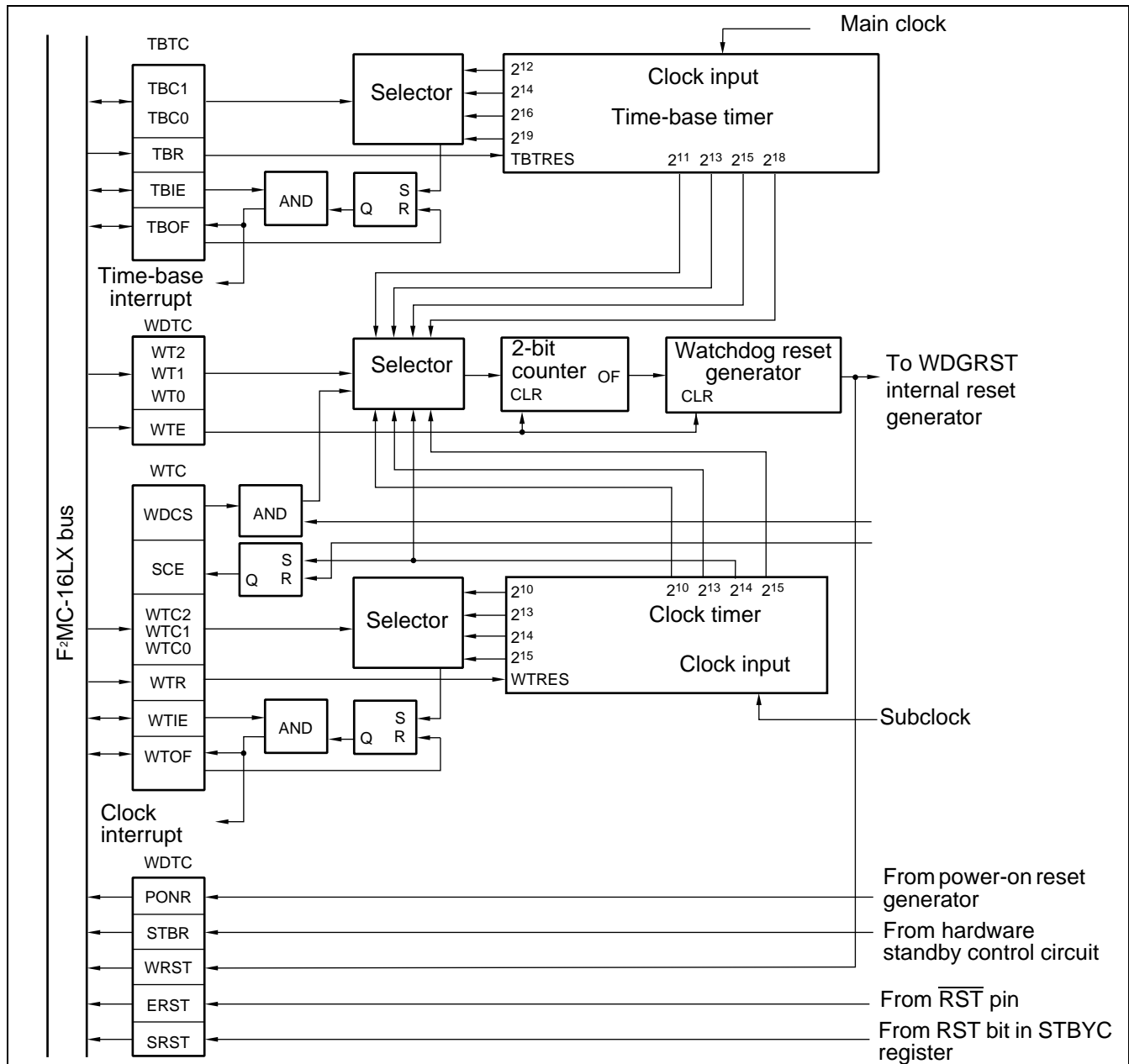

MB90580B Series

4. Clock timer

The clock timer has the functions of a watchdog timer clock source, a subclock oscillation settling time wait timer, and of a periodically interrupt generating interval timer.

(1) Register configuration

- Clock timer control register

Address	bit 7	bit 6	bit 5	bit 4	bit 3	bit 2	bit 1	bit 0	
0000AA _H	WDCS	SCE	WTIE	WTOF	WTR	WTC2	WTC1	WTC0	WTC
Access	(R/W)	(R)	(R/W)	(R/W)	(R/W)	(R/W)	(R/W)	(R/W)	
Initial value	(1)	(X)	(0)	(0)	(0)	(0)	(0)	(0)	

(2) Block Diagram

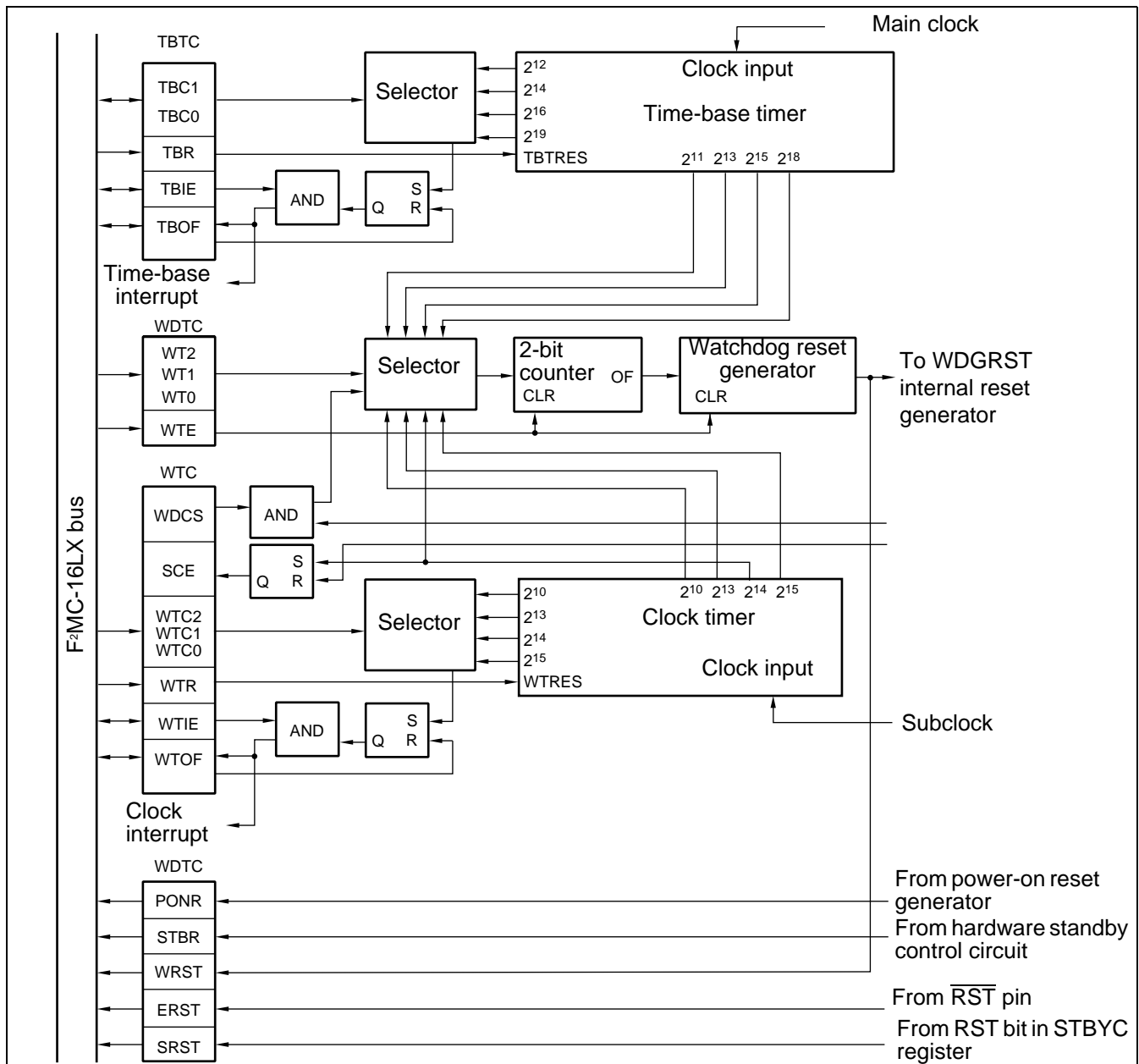

5. External Memory Access (External Bus Pin Control Circuit)

The external bus pin control circuit controls external bus pins used to expand the address/data buses of the CPU outside.

(1) Register configuration

- Automatic ready function selection register

bit	15	14	13	12	11	10	9	8		
Address	: 0000A5 _H	IOR1	IOR0	HMR1	HMR0	—	—	LMR1	LMR0	ARSR
Access		(W)	(W)	(W)	(W)	(—)	(—)	(W)	(W)	
Initial value		(0)	(0)	(1)	(1)	(—)	(—)	(0)	(0)	

- External address output control register

bit	7	6	5	4	3	2	1	0		
Address	: 0000A6 _H	E23	E22	E21	E20	E19	E18	E17	E16	HACR
Access		(W)	(W)	(W)	(W)	(W)	(W)	(W)	(W)	
Initial value		(0)	(0)	(0)	(0)	(0)	(0)	(0)	(0)	

- Bus control signal selection register

bit	15	14	13	12	11	10	9	8		
Address	: 0000A7 _H	CKE	RYE	HDE	IOBS	HMBS	WRE	LMBS	—	ECSR
Access		(W)	(W)	(W)	(W)	(W)	(W)	(W)	(—)	
Initial value		(0)	(0)	(0)	(0)	(0)	(0)	(0)	(—)	

(2) Block Diagram

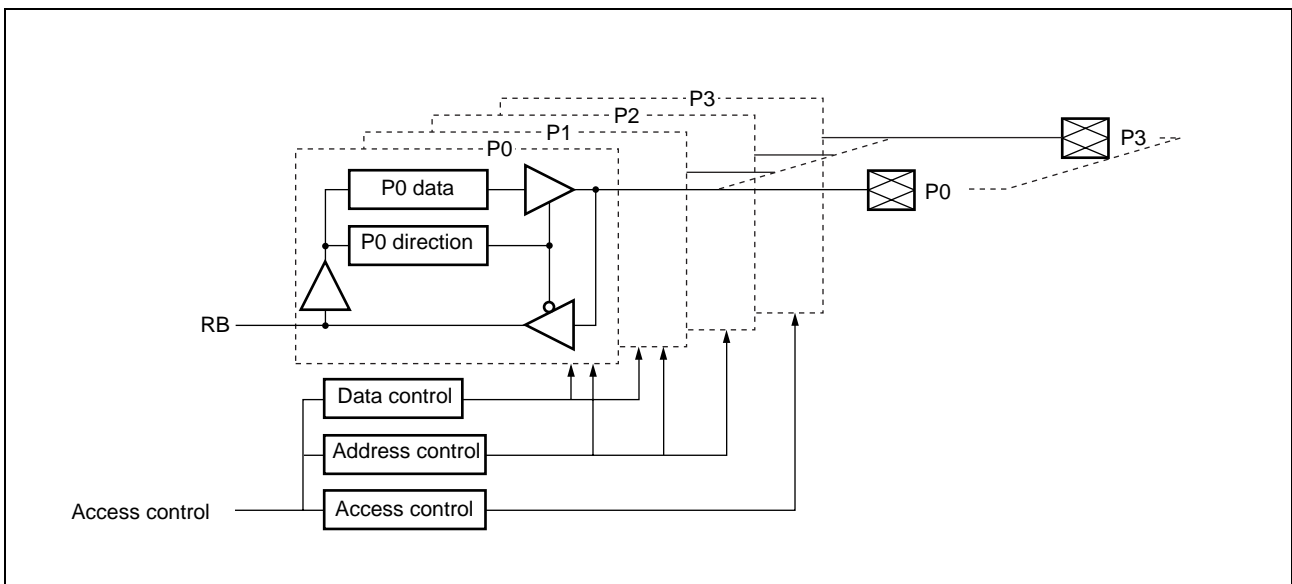

6. PWC Timer

The PWC (pulse width count) timer is a 16-bit multifunction up-counter with reload timer functions and input-signal pulse-width count functions as well.

The PWC timer consists of a 16-bit counter, a input pulse divider, a divide ratio control register, a count input pin, a pulse output pin, and a 16-bit control register.

(1) Features of the PWC timer

The PWC timer has the following features:

- Timer functions

Generates an interrupt request at set time intervals.

Outputs pulse signals synchronized with the timer cycle.

Selects the counter clock from among three internal clocks.

- Pulse-width count functions

Counts the time between external pulse input events.

Selects the counter clock from among three internal clocks.

Count mode

- H pulse width (rising edge to falling edge)/L pulse width (falling edge to rising edge)

- Rising-edge cycle (rising edge to falling edge)/Falling-edge cycle (falling edge to rising edge)

- Count between edges (rising or falling edge to falling or rising edge)

Capable of counting cycles by dividing input pulses by 2^2 , 2^4 , 2^6 , 2^8 using an 8-bit input divider.

Generates an interrupt request upon the completion of count operation.

Selects single or consecutive count operation.

(2) Register configuration

- PWC control status register (Upper byte)

bit	15	14	13	12	11	10	9	8	
Address	: 000055 _H								PWCSR upper
	STRT	STOP	EDIR	EDIE	OVIR	OVIE	ERR	POUT	
Access	(R/W)	(R/W)	(R/W)	(R/W)	(R/W)	(R/W)	(R/W)	(R/W)	
Initial value	(0)	(0)	(0)	(0)	(0)	(0)	(0)	(0)	

- PWC control status register (Lower byte)

bit	7	6	5	4	3	2	1	0	
Address	: 000054 _H								PWCSR lower
	CKS1	CKS0	Reserved	Reserved	S/C	MOD2	MOD1	MOD0	
Access	(R/W)	(R/W)	(R/W)	(R/W)	(R/W)	(R/W)	(R/W)	(R/W)	
Initial value	(0)	(0)	(0)	(0)	(0)	(0)	(0)	(0)	

- PWC data buffer register (Upper byte)

bit	15	14	13	12	11	10	9	8	
Address	: 000057 _H								PWCR upper
Access	(R/W)	(R/W)	(R/W)	(R/W)	(R/W)	(R/W)	(R/W)	(R/W)	
Initial value	(X)	(X)	(X)	(X)	(X)	(X)	(X)	(X)	

- PWC data buffer register (Lower byte)

bit	7	6	5	4	3	2	1	0	
Address	: 000056 _H								PWCR lower
Access	(R/W)	(R/W)	(R/W)	(R/W)	(R/W)	(R/W)	(R/W)	(R/W)	
Initial value	(X)	(X)	(X)	(X)	(X)	(X)	(X)	(X)	

- Divide ratio control register

bit	7	6	5	4	3	2	1	0	
Address	: 000058 _H								DIVR
	—	—	—	—	—	—	DIV1	DIV0	
Access	(—)	(—)	(—)	(—)	(—)	(—)	(R/W)	(R/W)	
Initial value	(—)	(—)	(—)	(—)	(—)	(—)	(0)	(0)	

- PWC noise filter register

bit	7	6	5	4	3	2	1	0	
Address	: 000086 _H								RNCR
	—	—	—	—	—	EN	SW1	SW0	
Access	(—)	(—)	(—)	(—)	(—)	(R/W)	(R/W)	(R/W)	
Initial value	(—)	(—)	(—)	(—)	(—)	(0)	(0)	(0)	

MB90580B Series

(3) Block Diagram

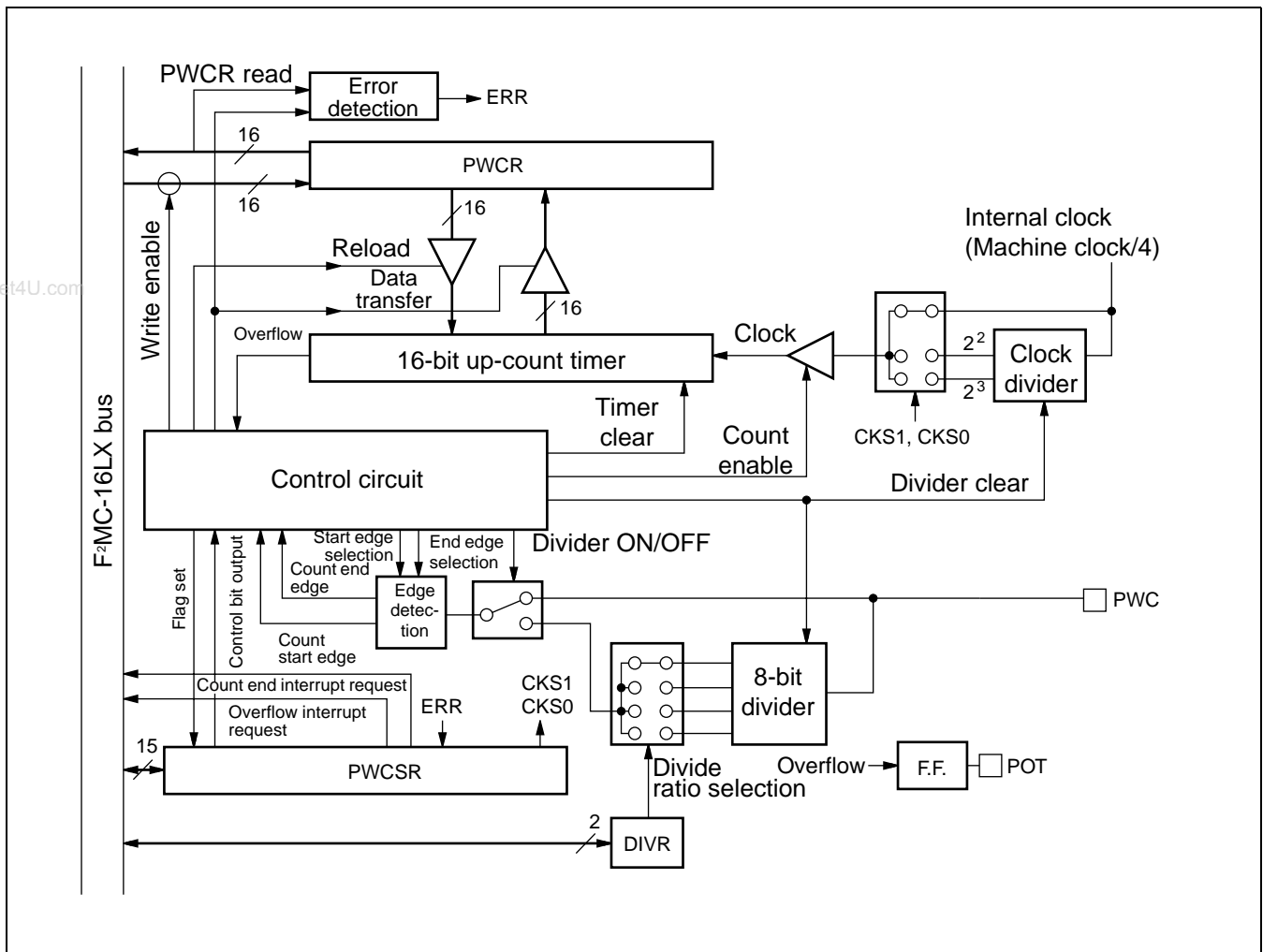

7. 16-bit I/O timer

The 16-bit I/O timer module consists of one 16-bit free run timer, four input capture circuits, and two output comparators. This module allows two independent waveforms to be output on the basis of the 16-bit free run timer. Input pulse width and external clock periods can, therefore, be measured.

(1) 16-bit free-run timer (1 channel)

The 16-bit free run timer consists of a 16-bit up-counter, a control register, and a prescaler. The value output from this timer/counter is used as the base time for the input capture and output compare modules.

- Counter operation clock (Selectable from among the following four)

Four internal clock cycles: $\phi/4$, $\phi/16$, $\phi/64$, $\phi/256$

ϕ : Machine clock

- Interrupts

An interrupt can be generated when the 16-bit free-run timer causes a counter overflow or by compare/match operation with compare register 0. (The compare/match operation requires the mode setting).

- Counter value

An interrupt can be generated when the 16-bit free-run timer causes a counter overflow or when a match with compare register 0 occurs (The compare/match function can be used by the appropriate mode setting).

- Initialization

The counter value can be initialized to "0000H" at a reset, soft clear operation, or a match with compare register 0.

(2) Output compare module (2 channels)

The output compare module consists of two 16-bit compare registers, compare output latches, and control registers. When the 16-bit free-run timer value matches the compare register value, this module generates an interrupt while inverting the output level.

- Two compare registers can operate independently.

Output pin and interrupt flag for each compare register

- A pair of compare registers can be used to control the output pin.

Two compare registers can be used to invert the output pin polarity.

- The initial value for each output pin can be set.
- An interrupt can be generated by compare/match operation.

(3) Input capture module (4 channels)

The input capture module consists of capture registers and control registers respectively associated with four independent external input pins. This module can hold the 16-bit free run timer value in the capture register. In addition, it can detect an arbitrary edge of the signal input from each external input pin to generate an interrupt.

- The external input signal edge to be detected can be selected.

One or both of the rising and falling edges can be selected.

- Four input capture channels can operate independently.
- An interrupt can be generated at a valid edge of the external input signal.

The extended intelligent I/O service can be activated by the interrupt by the input capture module.

MB90580B Series

(4) Register configuration

- Timer data register (upper)

bit	15	14	13	12	11	10	9	8	
Address : 00006D _H	T15	T14	T13	T12	T11	T10	T09	T08	TCDTH
Access	(R/W)	(R/W)	(R/W)	(R/W)	(R/W)	(R/W)	(R/W)	(R/W)	
Initial value	(0)	(0)	(0)	(0)	(0)	(0)	(0)	(0)	

- Timer data register (lower)

bit	7	6	5	4	3	2	1	0	
Address : 00006C _H	T07	T06	T05	T04	T03	T02	T01	T00	TCDTL
Access	(R/W)	(R/W)	(R/W)	(R/W)	(R/W)	(R/W)	(R/W)	(R/W)	
Initial value	(0)	(0)	(0)	(0)	(0)	(0)	(0)	(0)	

- Timer control status register

bit	7	6	5	4	3	2	1	0	
Address : 00006E _H	Re-served	IVF	IVFE	STOP	MODE	CLR	CLK1	CLK0	TCCS
Access	(—)	(R/W)	(R/W)	(R/W)	(R/W)	(R/W)	(R/W)	(R/W)	
Initial value	(0)	(0)	(0)	(0)	(0)	(0)	(0)	(0)	

- Compare register (upper)

bit	15	14	13	12	11	10	9	8	
Address : ch0 00005B _H : ch1 00005D _H	C15	C14	C13	C12	C11	C10	C09	C08	OCCP0 OCCP1
Access	(R/W)	(R/W)	(R/W)	(R/W)	(R/W)	(R/W)	(R/W)	(R/W)	
Initial value	(X)	(X)	(X)	(X)	(X)	(X)	(X)	(X)	

- Compare register (lower)

bit	7	6	5	4	3	2	1	0	
Address : ch0 00005A _H : ch1 00005C _H	C07	C06	C05	C04	C03	C02	C01	C00	OCCP0 OCCP1
Access	(R/W)	(R/W)	(R/W)	(R/W)	(R/W)	(R/W)	(R/W)	(R/W)	
Initial value	(X)	(X)	(X)	(X)	(X)	(X)	(X)	(X)	

- Compare control status register 1

bit	15	14	13	12	11	10	9	8	
Address : ch1 00005F _H	—	—	—	CMOD	OTE1	OTE0	OTD1	OTD0	OCS1
Access	(—)	(—)	(—)	(R/W)	(R/W)	(R/W)	(R/W)	(R/W)	
Initial value	(—)	(—)	(—)	(0)	(0)	(0)	(0)	(0)	

- Compare control status register 0

bit	7	6	5	4	3	2	1	0	
Address : ch0 00005E _H	ICP1	ICP0	ICE1	ICE0	—	—	CST1	CST0	OCS0
Access	(R/W)	(R/W)	(R/W)	(R/W)	(—)	(—)	(R/W)	(R/W)	
Initial value	(0)	(0)	(0)	(0)	(—)	(—)	(0)	(0)	

(Continued)

MB90580B Series

(Continued)

• Input capture register (upper)

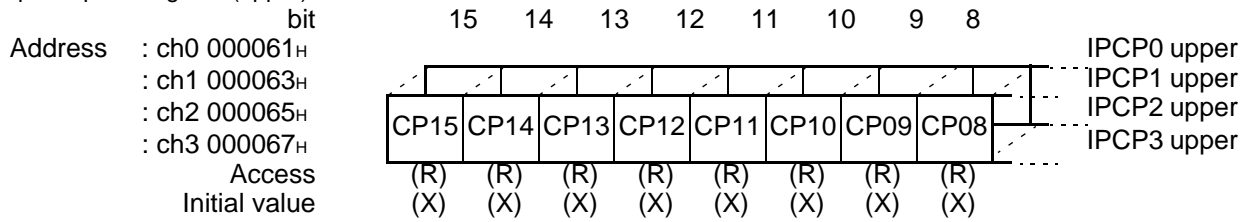

• Input capture register (lower)

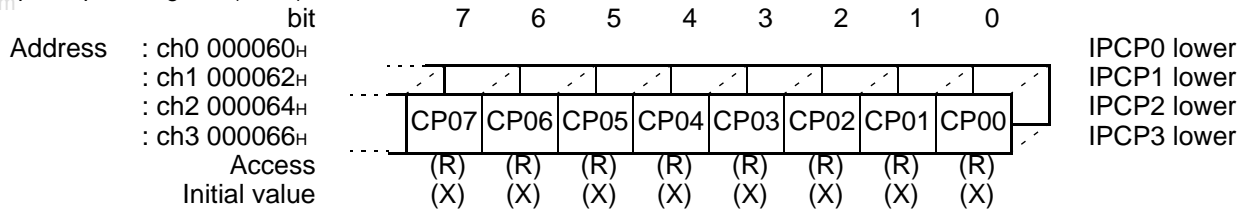

• Control status register 01

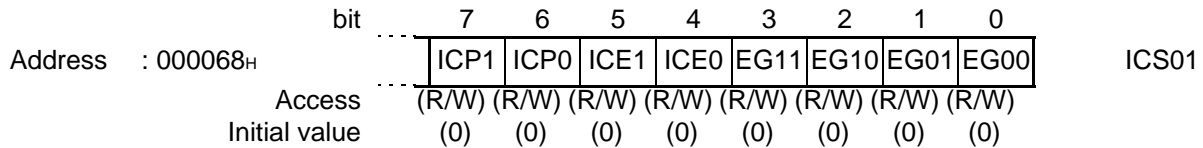

• Control status register 23

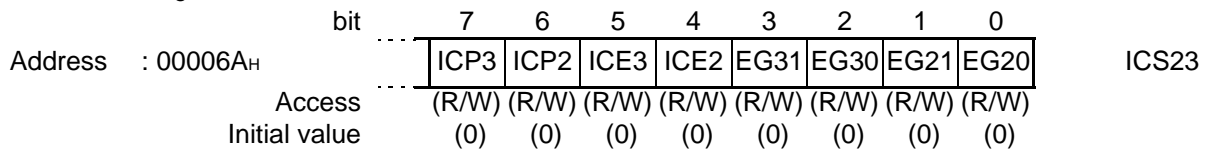

MB90580B Series

(5) Block Diagram

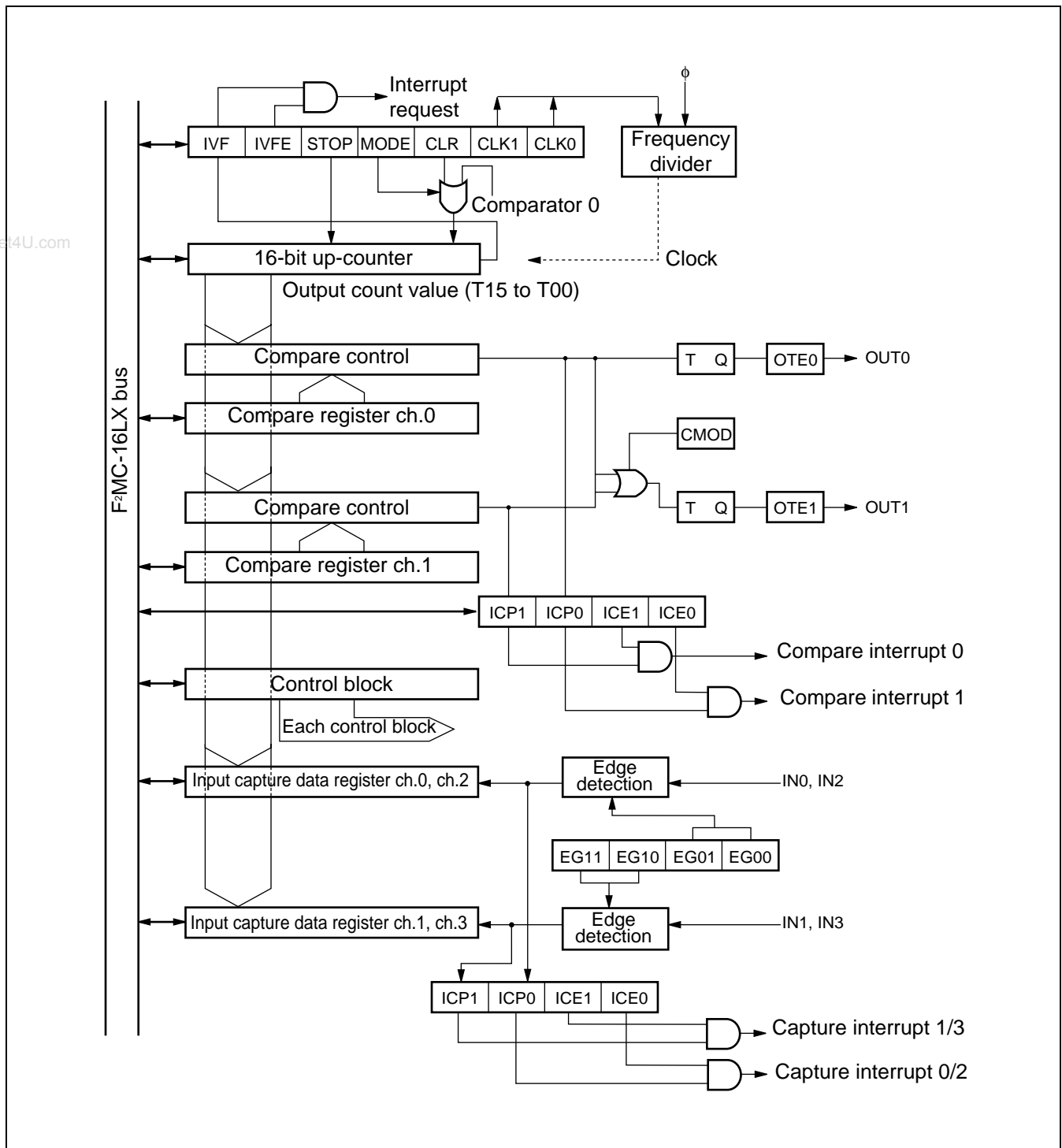

8. 16-bit Reload Timer

The 16-bit reload timer has three channels, each of which consists of a 16-bit down counter, a 16-bit reload register, an input pin (TIN), an output pin (TOT), and a control register. The input clock can be selected from among three internal clocks and one external clock.

(1) Register configuration

- Timer control status register (upper)

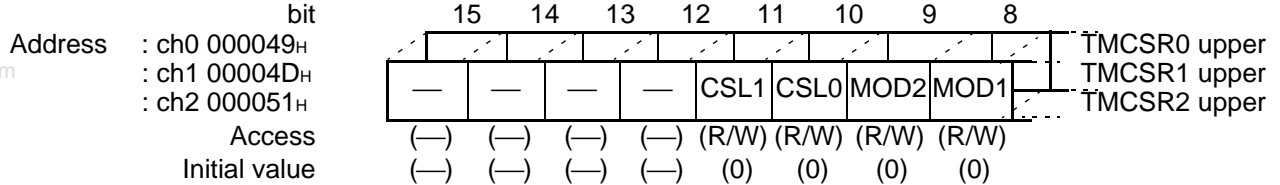

- Timer control status register (lower)

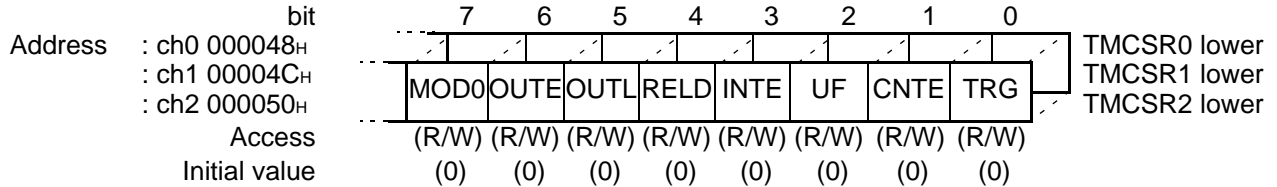

- 16-bit timer register (upper) /16 bit reload register (upper)

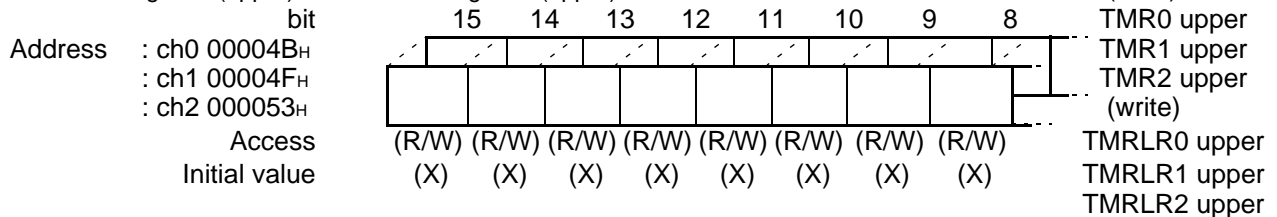

- 16-bit timer register (lower) /16 bit reload register (lower)

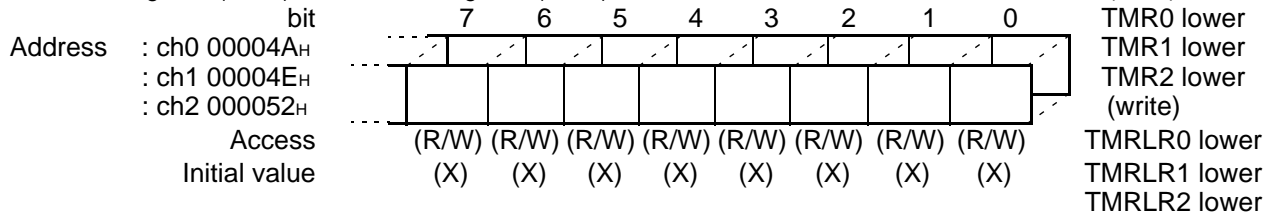

MB90580B Series

(2) Block Diagram

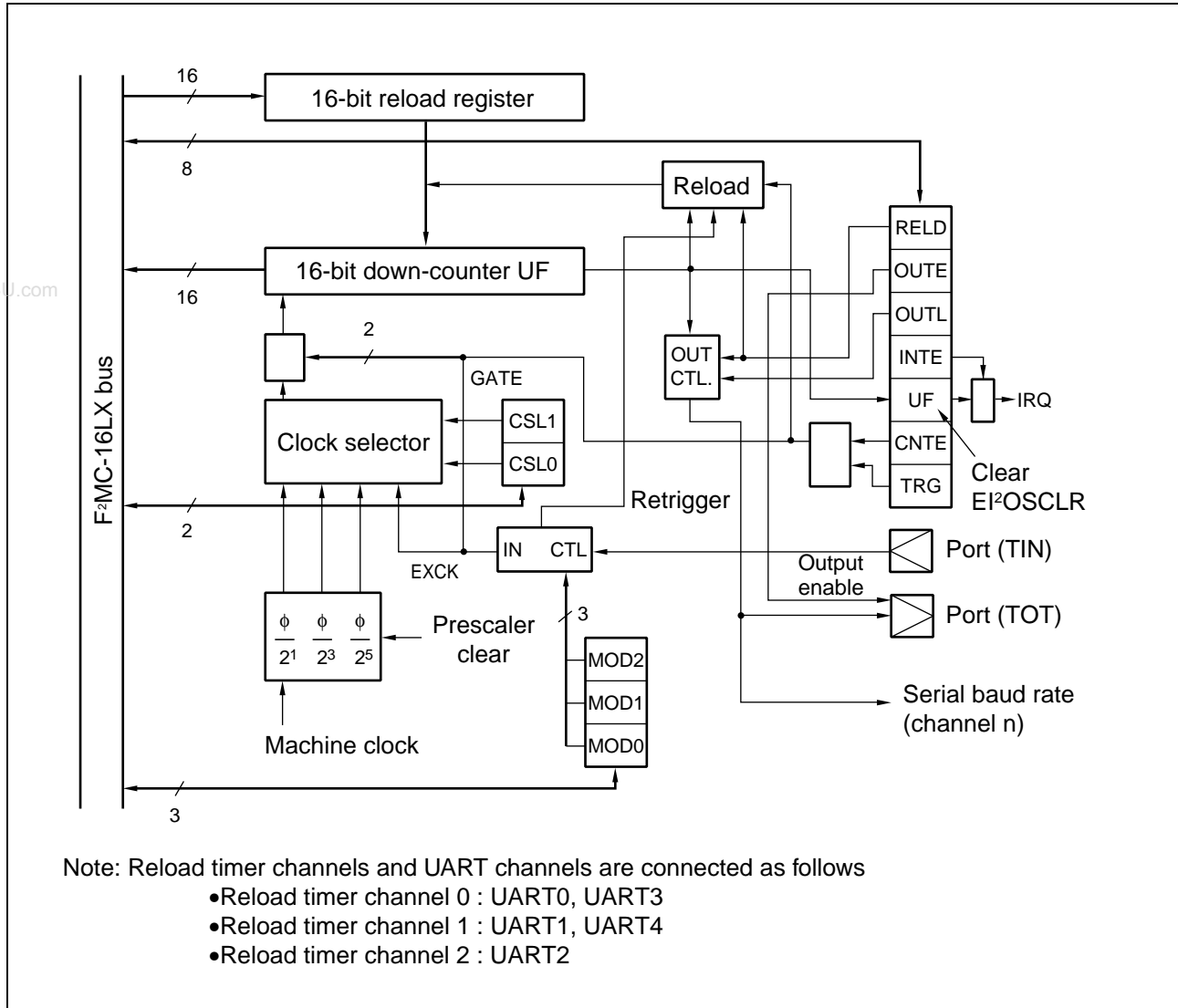

9. 8/16-bit PPG

8/16-bit PPG is an 8/16-bit reload timer module. The block performs PPG output in which the pulse output is controlled by the operation of the timer.

The hardware consists of two 8-bit down-counters, four 8-bit reload registers, one 16-bit control register, two external pulse output pins, and two interrupt outputs. The PPG has the following functions.

- 8-bit PPG output in two channels independent operation mode:
Two independent PPG output channels are available.
- 16-bit PPG output operation mode :
One 16-bit PPG output channel is available.
- 8 + 8-bit PPG output operation mode :
Variable-period 8-bit PPG output operation is available by using the output of channel 0 as the clock input to channel 1.
- PPG output operation :
Outputs pulse waveforms with variable period and duty ratio. Can be used as a D/A converter in conjunction with an external circuit.

(1) Register configuration

- PPG0 operating mode control register

bit	7	6	5	4	3	2	1	0	
Address	: ch0 0000044H								PPGC0
	PEN0	—	POE0	PIE0	PUF0	—	—	Re-served	
Access	(R/W)	(—)	(R/W)	(R/W)	(R/W)	(—)	(—)	(R/W)	
Initial value	(0)	(—)	(0)	(0)	(0)	(X)	(X)	(1)	

- PPG1 operating mode control register

bit	15	14	13	12	11	10	9	8	
Address	: ch1 0000045H								PPGC1
	PEN1	—	POE1	PIE1	PUF1	MD1	MD0	Re-served	
Access	(R/W)	(—)	(R/W)	(R/W)	(R/W)	(R/W)	(R/W)	(R/W)	
Initial value	(0)	(—)	(0)	(0)	(0)	(0)	(0)	(1)	

- PPG0 and 1 output control registers

bit	7	6	5	4	3	2	1	0	
Address	: ch0, 1 0000046H								PPGOE
	PCS2	PCS1	PCS0	PCM2	PCM1	PCM0	Re-served	Re-served	
Access	(R/W)	(R/W)	(R/W)	(R/W)	(R/W)	(R/W)	(R/W)	(R/W)	
Initial value	(0)	(0)	(0)	(0)	(0)	(0)	(0)	(0)	

- Reload register H

bit	15	14	13	12	11	10	9	8	
Address	: ch0 000041H : ch1 000043H								PRLH0 PRLH1
Access	(R/W)	(R/W)	(R/W)	(R/W)	(R/W)	(R/W)	(R/W)	(R/W)	
Initial value	(X)	(X)	(X)	(X)	(X)	(X)	(X)	(X)	

- Reload register L

bit	7	6	5	4	3	2	1	0	
Address	: ch0 000040H : ch1 000042H								PRLLO PRL11
Access	(R/W)	(R/W)	(R/W)	(R/W)	(R/W)	(R/W)	(R/W)	(R/W)	
Initial value	(X)	(X)	(X)	(X)	(X)	(X)	(X)	(X)	

MB90580B Series

(2) Block Diagram

- Block diagram (8 bit PPG (ch.0))

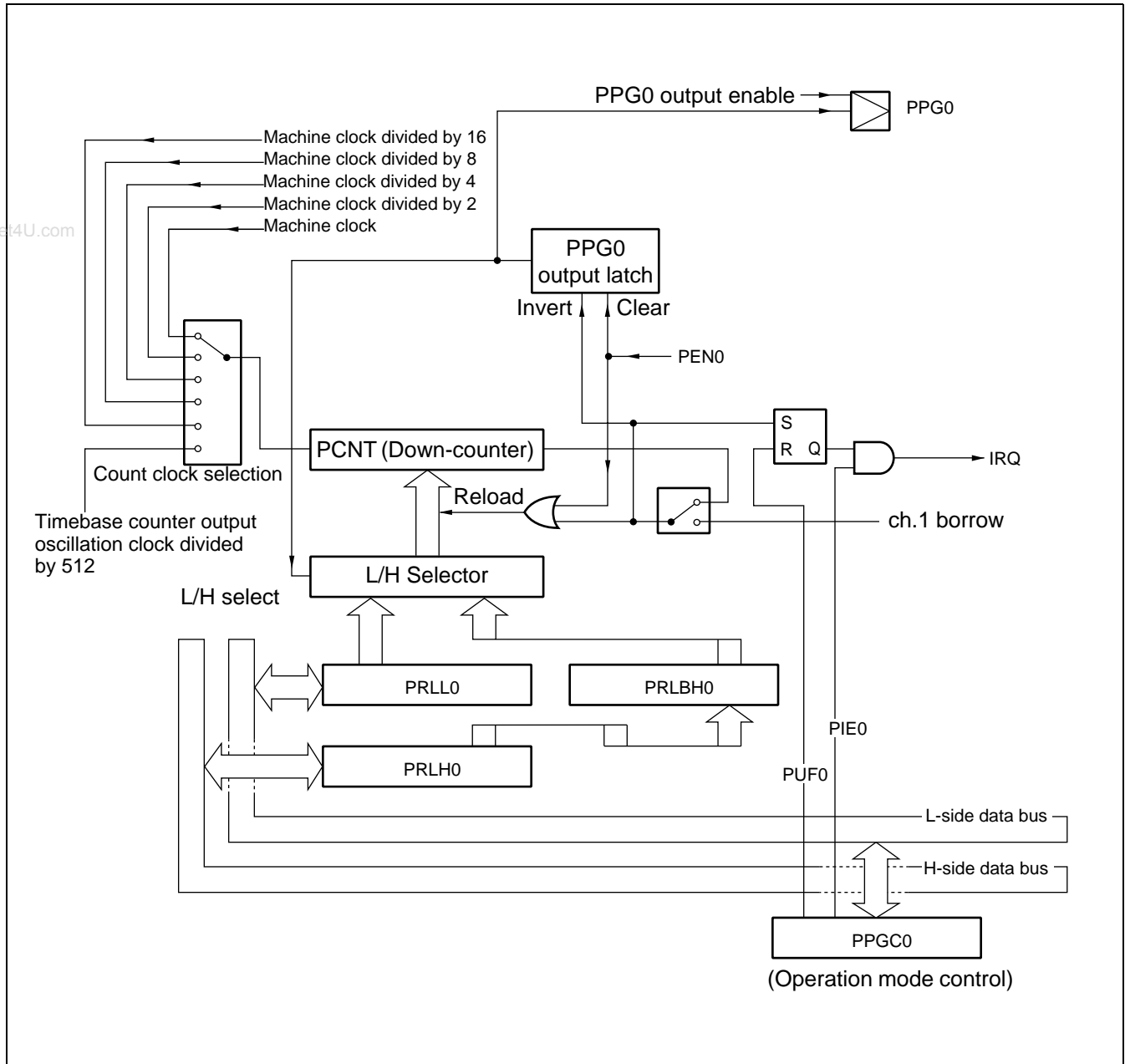

• Block Diagram (8/16 bit PPG (ch.1))

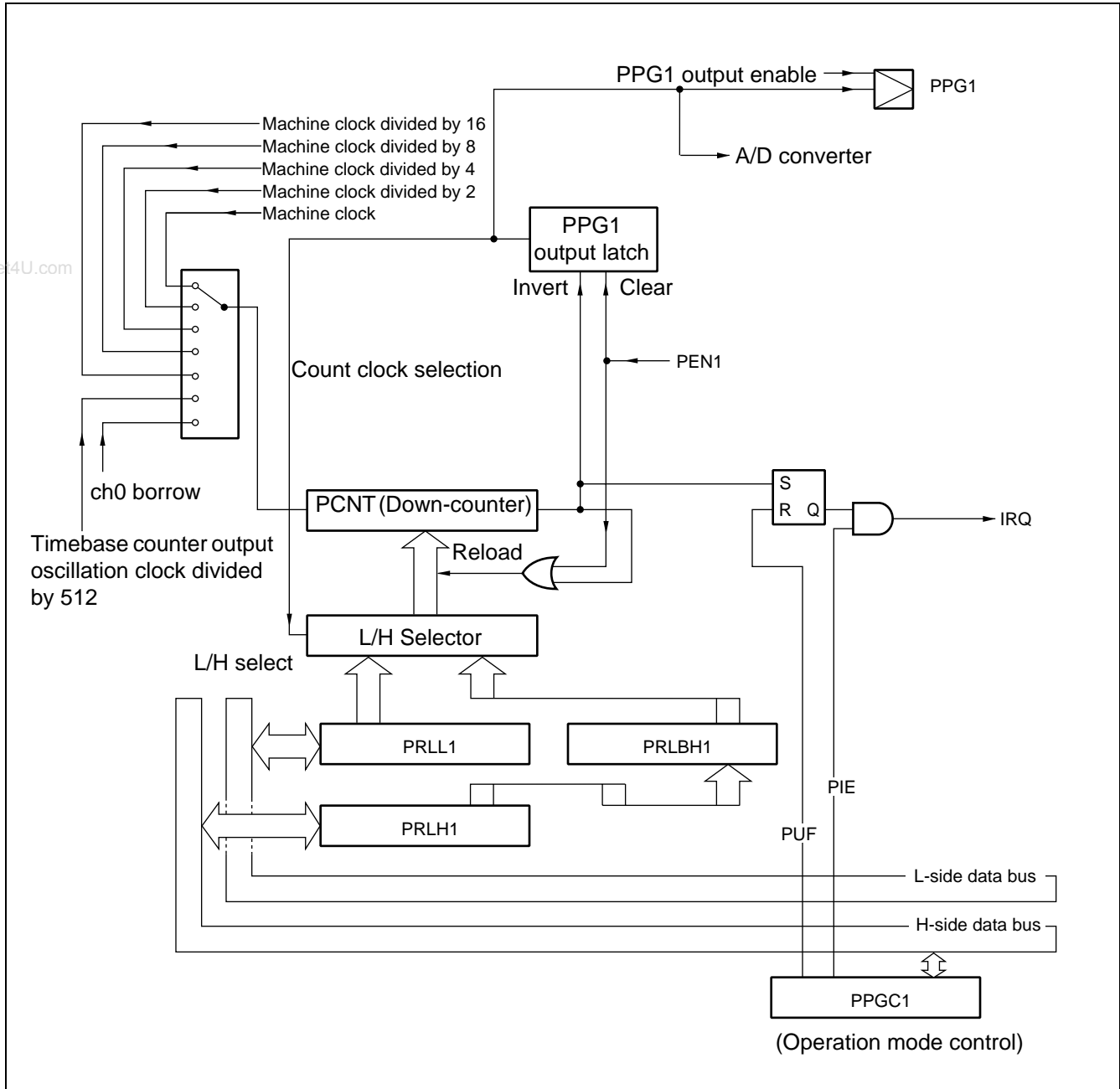

MB90580B Series

10. DTP/External Interrupts

The DTP (Data Transfer Peripheral) is a peripheral block that interfaces external peripherals to the F²MC-16LX CPU. The DTP receives DMA and interrupt processing requests from external peripherals and passes the requests to the F²MC-16LX CPU to activate the intelligent I/O service or interrupt processing. Two request levels ("H" and "L") are provided for the intelligent I/O service. For external interrupt requests, generation of interrupts on a rising or falling edge as well as on "H" and "L" levels can be selected, giving a total of four types.

(1) Register configuration

- Interrupt/DTP enable register

Address	: 0000030H	bit	7	6	5	4	3	2	1	0	
			EN7	EN6	EN5	EN4	EN3	EN2	EN1	EN0	ENIR
Access			(R/W)	(R/W)	(R/W)	(R/W)	(R/W)	(R/W)	(R/W)	(R/W)	
Initial value			(0)	(0)	(0)	(0)	(0)	(0)	(0)	(0)	

- Interrupt/DTP source register

Address	: 0000031H	bit	15	14	13	12	11	10	9	8	
			ER7	ER6	ER5	ER4	ER3	ER2	ER1	ER0	EIRR
Access			(R/W)	(R/W)	(R/W)	(R/W)	(R/W)	(R/W)	(R/W)	(R/W)	
Initial value			(X)	(X)	(X)	(X)	(X)	(X)	(X)	(X)	

- Request level setting register (lower)

Address	: 0000032H	bit	7	6	5	4	3	2	1	0	
			LB3	LA3	LB2	LA2	LB1	LA1	LB0	LA0	ELVR lower
Access			(R/W)	(R/W)	(R/W)	(R/W)	(R/W)	(R/W)	(R/W)	(R/W)	
Initial value			(0)	(0)	(0)	(0)	(0)	(0)	(0)	(0)	

- Request level setting register (upper)

Address	: 0000033H	bit	15	14	13	12	11	10	9	8	
			LB7	LA7	LB6	LA6	LB5	LA5	LB4	LA4	ELVR upper
Access			(R/W)	(R/W)	(R/W)	(R/W)	(R/W)	(R/W)	(R/W)	(R/W)	
Initial value			(0)	(0)	(0)	(0)	(0)	(0)	(0)	(0)	

(2) Block Diagram

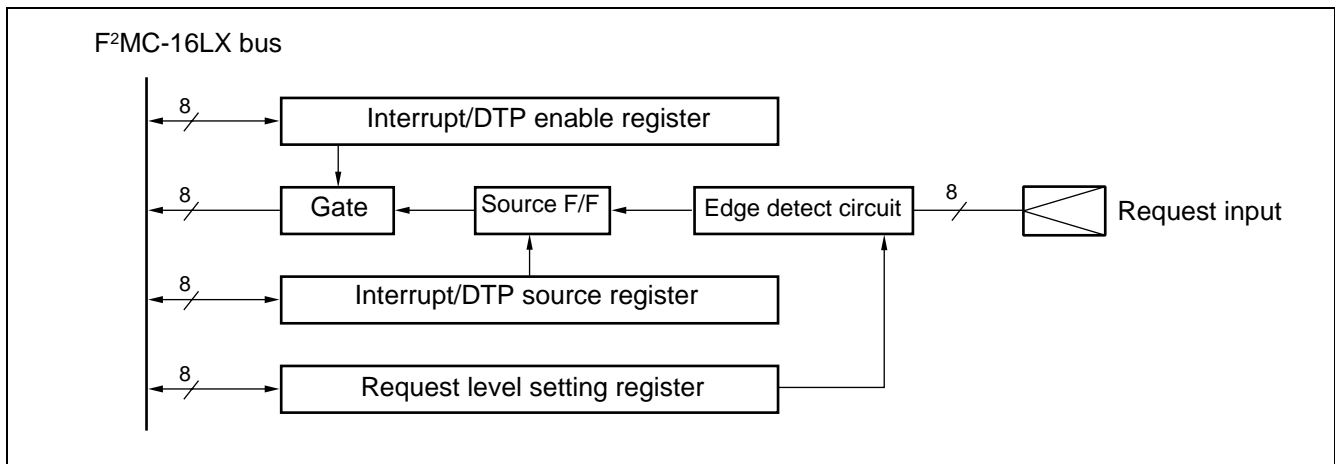

11. Delayed Interrupt Generation Module

The delayed interrupt generation module is used to generate the task switching interrupt. Interrupt requests to the F²MC-16LX CPU can be generated and cleared by software using this module.

(1) Register configuration

The DIRR register controls generation and clearing of delayed interrupt requests. Writing "1" to the register generates a delayed interrupt request. Writing "0" to the register clears the delayed interrupt request. The register is set to the interrupt cleared state by a reset. Either "0" or "1" can be written to the reserved bits. However, considering possible future extensions, it is recommended that the set bit and clear bit instructions are used for register access.

- Delayed interrupt generation/release register

		bit	15	14	13	12	11	10	9	8	
Address	: 00009F _H		—	—	—	—	—	—	—	R0	DIRR
Access			(—)	(—)	(—)	(—)	(—)	(—)	(—)	(R/W)	
Initial value			(—)	(—)	(—)	(—)	(—)	(—)	(—)	(0)	

(2) Block Diagram

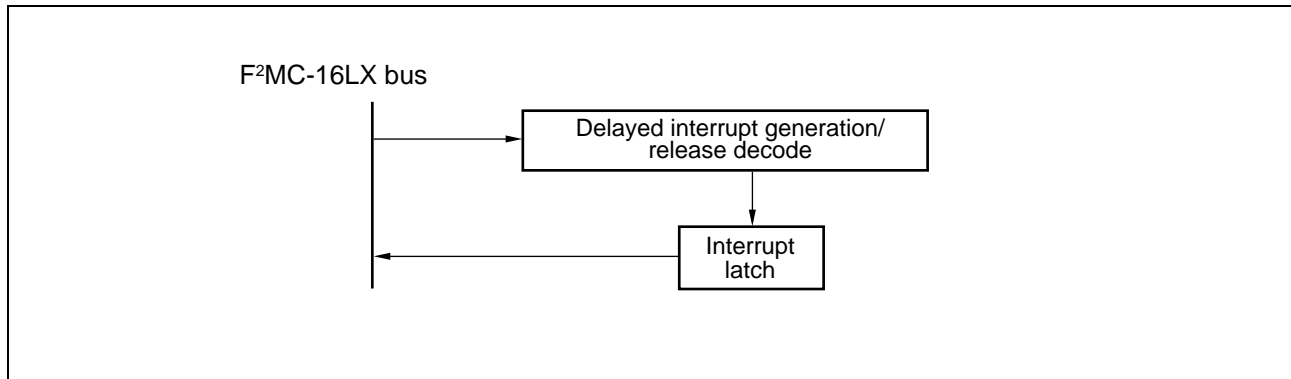

MB90580B Series

12. A/D Converter

The A/D converter converts analog input voltages to digital values. The A/D converter has the following features.

- Conversion time: Minimum of 34.7 μ s per channel (for a 12 MHz machine clock)
- Uses RC-type successive approximation conversion with a sample and hold circuit.
- 8/10-bit resolution
- Eight program-selectable analog input channels

Single conversion mode: Selectively convert one channel.

Scan conversion mode: Continuously convert multiple channels. Maximum of 8 program selectable channels.

Continuous conversion mode : Repeatedly convert specified channels.

Stop conversion mode: Convert one channel then halt until the next activation. (Enables synchronization of the conversion start timing.)

- An A/D conversion completion interrupt request.

An A/D conversion completion interrupt request to the CPU can be generated on the completion of A/D conversion. This interrupt can activate EI²OS to transfer the result of A/D conversion to memory and is suitable for continuous operation.

- Activation by software, external trigger (falling edge), or timer (rising edge) can be selected.

(1) Register configuration

- Control status register (upper)

bit	15	14	13	12	11	10	9	8	
Address : 000037H	BUSY	INT	INTE	PAUS	STS1	STS0	STRT	Re-served	ADCS2
Access	(R/W)	(R/W)	(R/W)	(R/W)	(R/W)	(R/W)	(R/W)	(—)	
Initial value	(0)	(0)	(0)	(0)	(0)	(0)	(0)	(0)	

- Control status register (lower)

bit	7	6	5	4	3	2	1	0	
Address : 000036H	MD1	MD0	ANS2	ANS1	ANS0	ANE2	ANE1	ANE0	ADCS1
Access	(R/W)	(R/W)	(R/W)	(R/W)	(R/W)	(R/W)	(R/W)	(R/W)	
Initial value	(0)	(0)	(0)	(0)	(0)	(0)	(0)	(0)	

- Data register (upper)

bit	15	14	13	12	11	10	9	8	
Address : 000039H	SELB	ST1	ST0	CT1	CT0	—	D9	D8	ADCR2
Access	(W)	(W)	(W)	(W)	(W)	(—)	(R)	(R)	
Initial value	(0)	(0)	(0)	(0)	(1)	(—)	(X)	(X)	

- Data register (lower)

bit	7	6	5	4	3	2	1	0	
Address : 000038H	D7	D6	D5	D4	D3	D2	D1	D0	ADCR1
Access	(R)	(R)	(R)	(R)	(R)	(R)	(R)	(R)	
Initial value	(X)	(X)	(X)	(X)	(X)	(X)	(X)	(X)	

(2) Block Diagram

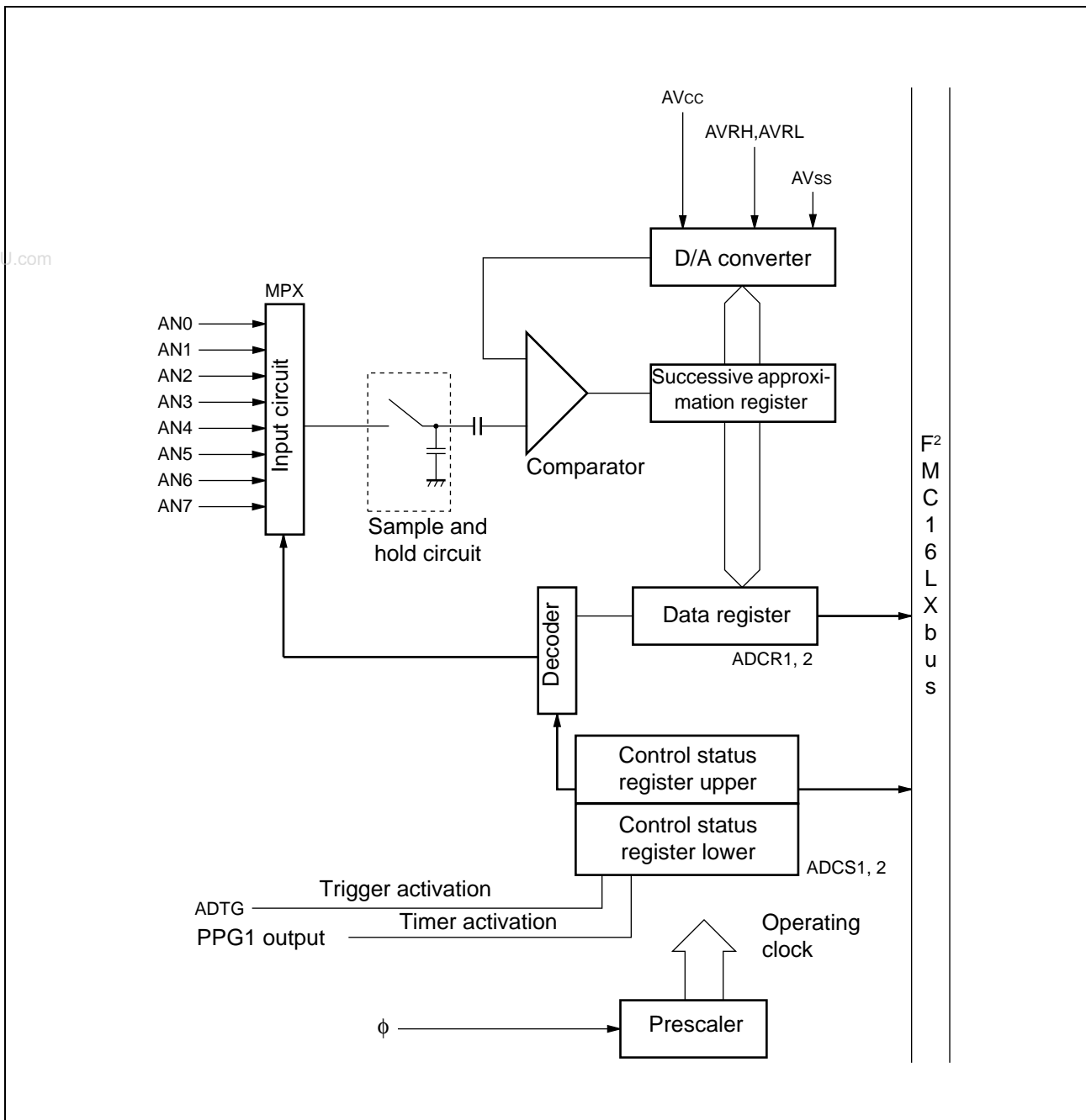

MB90580B Series

13. D/A Converter

D/A converter is an R-2R type D/A converter with 8-bit resolution. The device contains two D/A converters. The D/A control register controls the output of the two D/A converters independently.

(1) Register configuration

- D/A converter data register 1

	bit	15	14	13	12	11	10	9	8	
Address	:	00003B _H								DAT1
		DA17	DA16	DA15	DA14	DA13	DA12	DA11	DA10	
Access		(R/W)	(R/W)	(R/W)	(R/W)	(R/W)	(R/W)	(R/W)	(R/W)	
Initial value		(0)	(0)	(0)	(0)	(0)	(0)	(0)	(0)	

- D/A converter data register 0

	bit	7	6	5	4	3	2	1	0	
Address	:	00003A _H								DAT0
		DA07	DA06	DA05	DA04	DA03	DA02	DA01	DA00	
Access		(R/W)	(R/W)	(R/W)	(R/W)	(R/W)	(R/W)	(R/W)	(R/W)	
Initial value		(0)	(0)	(0)	(0)	(0)	(0)	(0)	(0)	

- D/A control register 1

	bit	15	14	13	12	11	10	9	8	
Address	:	00003D _H								DACR1
		—	—	—	—	—	—	—	DAE1	
Access		(—)	(—)	(—)	(—)	(—)	(—)	(—)	(R/W)	
Initial value		(—)	(—)	(—)	(—)	(—)	(—)	(—)	(0)	

- D/A control register 0

	bit	7	6	5	4	3	2	1	0	
Address	:	00003C _H								DACR0
		—	—	—	—	—	—	—	DAE0	
Access		(—)	(—)	(—)	(—)	(—)	(—)	(—)	(R/W)	
Initial value		(—)	(—)	(—)	(—)	(—)	(—)	(—)	(0)	

(2) Block Diagram

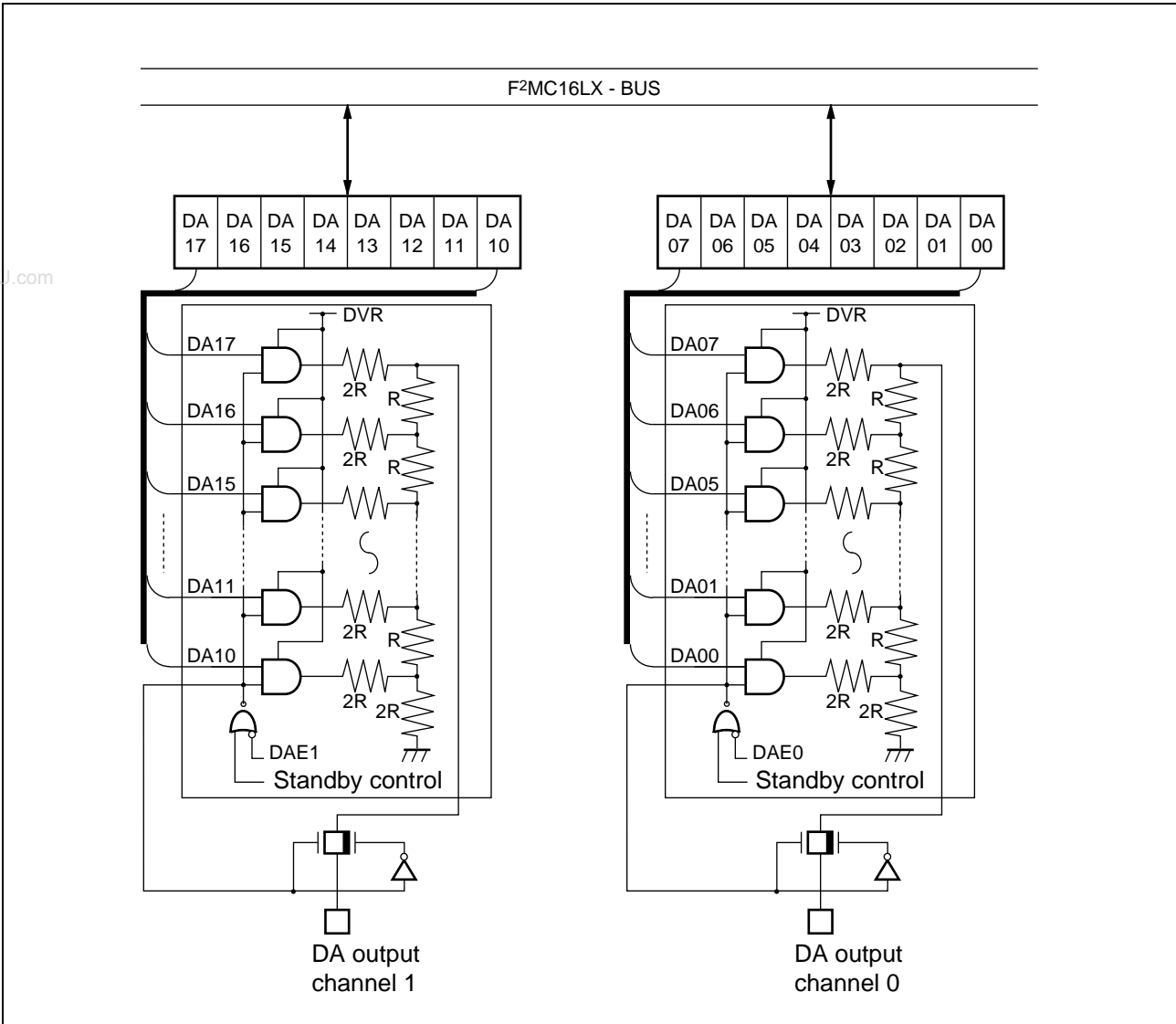

MB90580B Series

14. Communication Prescaler

The register (clock division control register) of the communication prescaler controls division of the machine clock frequency. It is designed to provide a fixed baud rate for a variety of machine clock frequencies depending on the user setting.

The output from the communication prescaler is used by the UARTs.

(1) Register configuration

- Clock division control registers 0 to 4

		15	14	13	12	11	10	9	8	...	
Address :	00002C _H	MD	—	—	—	DIV3	DIV2	DIV1	DIV0	...	CDCR0
	00002E _H									...	CDCR1
	000034 _H										CDCR2
	000087 _H										CDCR3
	00008F _H										CDCR4
		Access	(—)	(—)	(—)	(R/W)	(R/W)	(R/W)	(R/W)	...	
		Initial value	(0)	(—)	(—)	(1)	(1)	(1)	(1)		

15. UART

The UART is a serial I/O port for asynchronous (start-stop) communication or clock-synchronous communication.

The UART has the following features:

- Full-duplex double buffering
- Capable of asynchronous (start-stop) and CLK-synchronous communications
- Support for the multiprocessor mode
- Dedicated baud rate generator integratedBaud rate

Operation	Baud rate
Asynchronous	31250/9615/4808/2404/1202 bps
CLK synchronous	2 M/1 M/500 K/250 K/125 K/62.5 Kbps

* : Assuming internal machine clock frequencies of 6, 8, 10, 12, and 16 MHz

- Capable of setting an arbitrary baud rate using an external clock
- Error detection functions (parity, framing, overrun)
- HRz sign transfer signal

(1) Register configuration

- Serial mode register

Address	bit	7	6	5	4	3	2	1	0	
0000020H										SMR0
0000024H		MD1	MD0	CS2	CS1	CS0	Re-served	SCKE	SOE	SMR1
0000028H										SMR2
0000082H	Access	(R/W)	(R/W)	(R/W)	(R/W)	(R/W)	(R/W)	(R/W)	(R/W)	SMR3
0000088H	Initial value	(0)	(0)	(0)	(0)	(0)	(0)	(0)	(0)	SMR4

- Serial control register

Address	bit	15	14	13	12	11	10	9	8	
0000021H										SCR0
0000025H		PEN	P	SBL	CL	A/D	REC	RXE	TXE	SCR1
0000029H										SCR2
0000083H	Access	(R/W)	(R/W)	(R/W)	(R/W)	(R/W)	(R/W)	(R/W)	(R/W)	SCR3
0000089H	Initial value	(0)	(0)	(0)	(0)	(0)	(1)	(0)	(0)	SCR4

- Serial input register/serial output register

Address	bit	7	6	5	4	3	2	1	0	(read)	(write)
0000022H										SIDR0	SODR0
0000026H		D7	D6	D5	D4	D3	D2	D1	D0	SIDR1	SODR1
000002AH	Access	(R/W)	(R/W)	(R/W)	(R/W)	(R/W)	(R/W)	(R/W)	(R/W)	SIDR2	SODR2
0000084H	Initial value	(X)	(X)	(X)	(X)	(X)	(X)	(X)	(X)	SIDR3	SODR3
000008AH										SIDR4	SODR4

- Serial status register

Address	bit	15	14	13	12	11	10	9	8	
0000023H										SSR0
0000027H		PE	ORE	FRE	RDRF	TDRE	—	RIE	TIE	SSR1
000002BH										SSR2
0000085H	Access	(R/W)	(R/W)	(R/W)	(R/W)	(R/W)	(—)	(R/W)	(R/W)	SSR3
000008BH	Initial value	(0)	(0)	(0)	(0)	(1)	(—)	(0)	(0)	SSR4

MB90580B Series

(2) Block Diagram

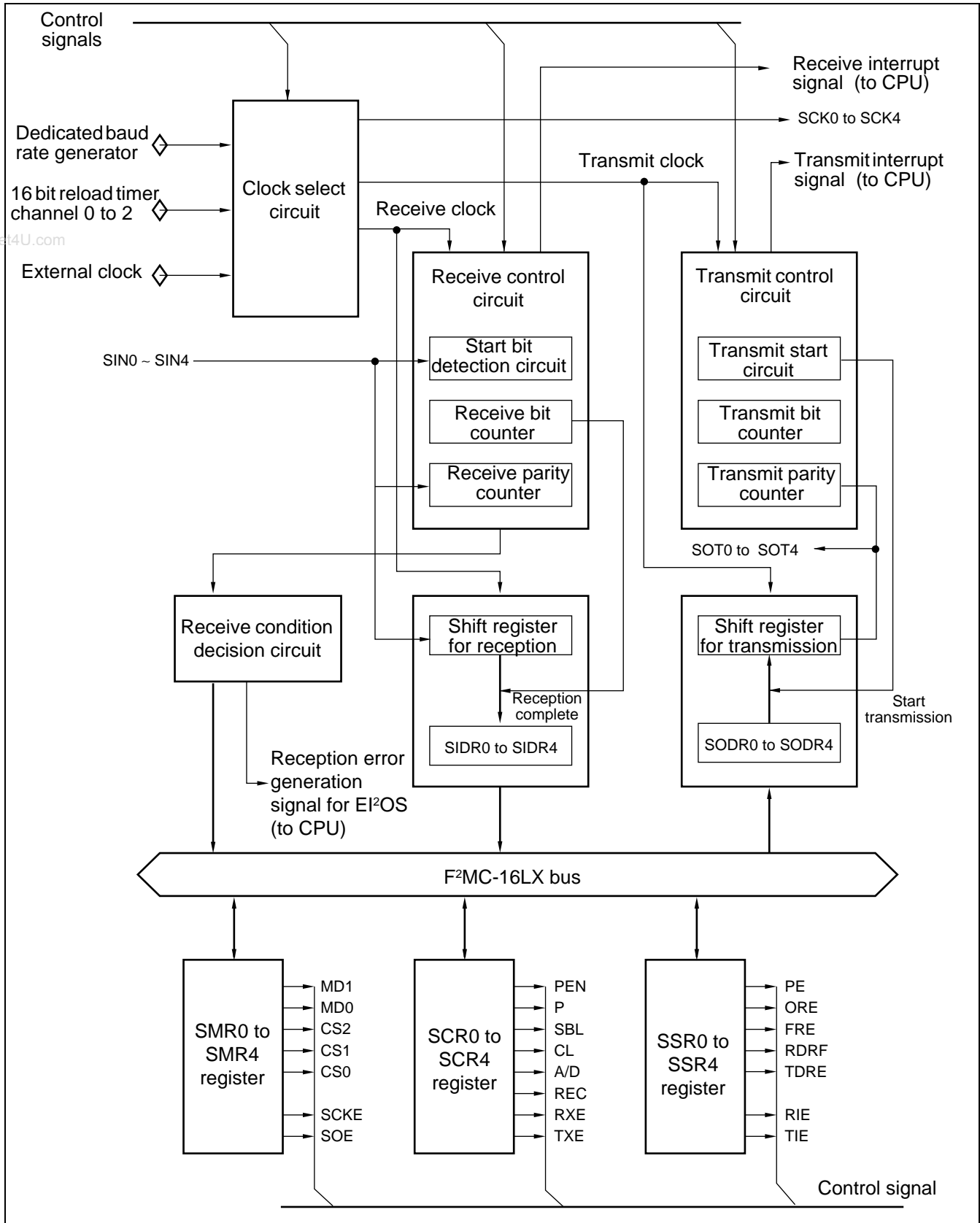

16. IEBus™ Controller

The IEBus™ (Inter-Equipment Bus) is a small-scale, two-wire serial bus interface designed for data transfer between pieces of equipment.

This interface is applicable, for example, as a bus interface for controlling vehicle-mounted devices.

IEBus™ has the following features:

- Multitasking
Any of the units connected to the IEBus™ can transmit data to another one.
- Broadcast function (Communication from one unit to multiple units)
Group broadcast : Broadcast to a group of units
All-unit broadcast : Broadcast to all units
- Three modes can be selected for different transmission speeds.

	IEBus™ internal frequency	
	6 MHz	6.29 MHz
Mode 0	About 3.9 Kbps	About 4.1 Kbps
Mode 1	About 17 Kbps	About 18 Kbps
Mode 2	About 26 Kbps	About 27 Kbps

- Data buffer for transmission
8-byte FIFO buffer
- Data buffer for reception
8-byte FIFO buffer
- CPU internal operating frequency (12 MHz, 12.58 MHz)
- Frequency tolerance
In mode 0 or 1 : $\pm 1.5\%$
In mode 2 : $\pm 0.5\%$

(1) Register configuration

- Local-office address setting register H

	bit	15	14	13	12	11	10	9	8	
Address	:	000071 _H								
		Reserved	Reserved	Reserved	Reserved	MA11	MA10	MA09	MA08	MAWH
Access		(R/W)	(R/W)	(R/W)	(R/W)	(R/W)	(R/W)	(R/W)	(R/W)	
Initial value		(X)	(X)	(X)	(X)	(X)	(X)	(X)	(X)	

- Local-office address setting register L

	bit	7	6	5	4	3	2	1	0	
Address	:	000070 _H								
		MA07	MA06	MA05	MA04	MA03	MA02	MA01	MA00	MAWL
Access		(R/W)	(R/W)	(R/W)	(R/W)	(R/W)	(R/W)	(R/W)	(R/W)	
Initial value		(X)	(X)	(X)	(X)	(X)	(X)	(X)	(X)	

- Slave address setting register H

	bit	15	14	13	12	11	10	9	8	
Address	:	000073 _H								
		Reserved	Reserved	Reserved	Reserved	SA11	SA10	SA09	SA08	SAWH
Access		(R/W)	(R/W)	(R/W)	(R/W)	(R/W)	(R/W)	(R/W)	(R/W)	
Initial value		(X)	(X)	(X)	(X)	(X)	(X)	(X)	(X)	

(Continued)

MB90580B Series

- Slave address setting register L

bit	7	6	5	4	3	2	1	0	
Address	: 000072 _H								SAWL
	SA07	SA06	SA05	SA04	SA03	SA02	SA01	SA00	
Access	(R/W)	(R/W)	(R/W)	(R/W)	(R/W)	(R/W)	(R/W)	(R/W)	
Initial value	(X)	(X)	(X)	(X)	(X)	(X)	(X)	(X)	

- Broadcast control bit setting register

bit	15	14	13	12	11	10	9	8	
Address	: 000075 _H								DCWR
	DO3	DO2	DO1	DO0	C3	C2	C1	C0	
Access	(R/W)	(R/W)	(R/W)	(R/W)	(R/W)	(R/W)	(R/W)	(R/W)	
Initial value	(0)	(0)	(0)	(0)	(0)	(0)	(0)	(0)	

- Broadcast control bit read register

bit	15	14	13	12	11	10	9	8	
Address	: 00007F _H								DCRR
	DO3	DO2	DO1	DO0	C3	C2	C1	C0	
Access	(R)	(R)	(R)	(R)	(R)	(R)	(R)	(R)	
Initial value	(0)	(0)	(0)	(X)	(X)	(X)	(X)	(X)	

- Message length bit setting register

bit	7	6	5	4	3	2	1	0	
Address	: 000074 _H								DEWR
	DE7	DE6	DE5	DE4	DE3	DE2	DE1	DE0	
Access	(R/W)	(R/W)	(R/W)	(R/W)	(R/W)	(R/W)	(R/W)	(R/W)	
Initial value	(0)	(0)	(0)	(0)	(0)	(0)	(0)	(0)	

- Message length bit read register

bit	7	6	5	4	3	2	1	0	
Address	: 00007E _H								DERR
	DE7	DE6	DE5	DE4	DE3	DE2	DE1	DE0	
Access	(R)	(R)	(R)	(R)	(R)	(R)	(R)	(R)	
Initial value	(X)	(X)	(X)	(X)	(X)	(X)	(X)	(X)	

- Command register H

bit	15	14	13	12	11	10	9	8	
Address	: 000077 _H								CMRH
	MD1	MD0	PCOM	RIE	TIE	GOTM	GOTS	Reserved	
Access	(R/W)	(R/W)	(R/W)	(R/W)	(R/W)	(R/W)	(R/W)	(R/W)	
Initial value	(0)	(0)	(0)	(0)	(0)	(0)	(0)	(X)	

- Command register L

bit	7	6	5	4	3	2	1	0	
Address	: 000076 _H								CMRL
	RXS	TXS	TIT1	TIT0	CS1	CS0	RDBC	WDDBC	
Access	(R/W)	(R/W)	(R/W)	(R/W)	(R/W)	(R/W)	(R/W)	(R/W)	
Initial value	(1)	(1)	(0)	(0)	(0)	(0)	(0)	(0)	

- Status register H

bit	15	14	13	12	11	10	9	8	
Address	: 000079 _H								STRH
	COM	TE	PEF	ACK	RIF	TIF	TSL	EOD	
Access	(R)	(R/W)	(R)	(R)	(R/W)	(R/W)	(R)	(R)	
Initial value	(0)	(0)	(X)	(X)	(0)	(0)	(0)	(0)	

(Continued)

(Continued)

• Status register L

bit	7	6	5	4	3	2	1	0	
Address	: 000078 _H								STRL
	WDBF	RDBF	WDBE	RDBE	ST3	ST2	ST1	ST0	
Access	(R)	(R)	(R)	(R)	(R)	(R)	(R)	(R)	
Initial value	(0)	(0)	(1)	(1)	(X)	(X)	(X)	(X)	

• Lock read register H

bit	15	14	13	12	11	10	9	8	
Address	: 00007B _H								LRRH
	Reserved	Reserved	Reserved	LOC	LD11	LD10	LD09	LD08	
Access	(R)	(R)	(R)	(R/W)	(R)	(R)	(R)	(R)	
Initial value	(1)	(1)	(1)	(0)	(X)	(X)	(X)	(X)	

• Lock read register L

bit	7	6	5	4	3	2	1	0	
Address	: 00007A _H								LRRL
	LD07	LD06	LD05	LD04	LD03	LD02	LD01	LD00	
Access	(R)	(R)	(R)	(R)	(R)	(R)	(R)	(R)	
Initial value	(X)	(X)	(X)	(X)	(X)	(X)	(X)	(X)	

• Master address read register H

bit	15	14	13	12	11	10	9	8	
Address	: 00007D _H								MARH
	Reserved	Reserved	Reserved	Reserved	MA11	MA10	MA09	MA08	
Access	(R)	(R)	(R)	(R)	(R)	(R)	(R)	(R)	
Initial value	(1)	(1)	(1)	(1)	(X)	(X)	(X)	(X)	

• Master address read register L

bit	7	6	5	4	3	2	1	0	
Address	: 00007C _H								MARL
	MA07	MA06	MA05	MA04	MA03	MA02	MA01	MA00	
Access	(R)	(R)	(R)	(R)	(R)	(R)	(R)	(R)	
Initial value	(X)	(X)	(X)	(X)	(X)	(X)	(X)	(X)	

• Read data buffer

bit	15	14	13	12	11	10	9	8	
Address	: 000081 _H								RDB
	RD7	RD6	RD5	RD4	RD3	RD2	RD1	RD0	
Access	(R)	(R)	(R)	(R)	(R)	(R)	(R)	(R)	
Initial value	(X)	(X)	(X)	(X)	(X)	(X)	(X)	(X)	

• Write data buffer

bit	7	6	5	4	3	2	1	0	
Address	: 000080 _H								WDB
	WD7	WD6	WD5	WD4	WD3	WD2	WD1	WD0	
Access	(W)	(W)	(W)	(W)	(W)	(W)	(W)	(W)	
Initial value	(X)	(X)	(X)	(X)	(X)	(X)	(X)	(X)	

MB90580B Series

(2) Block Diagram

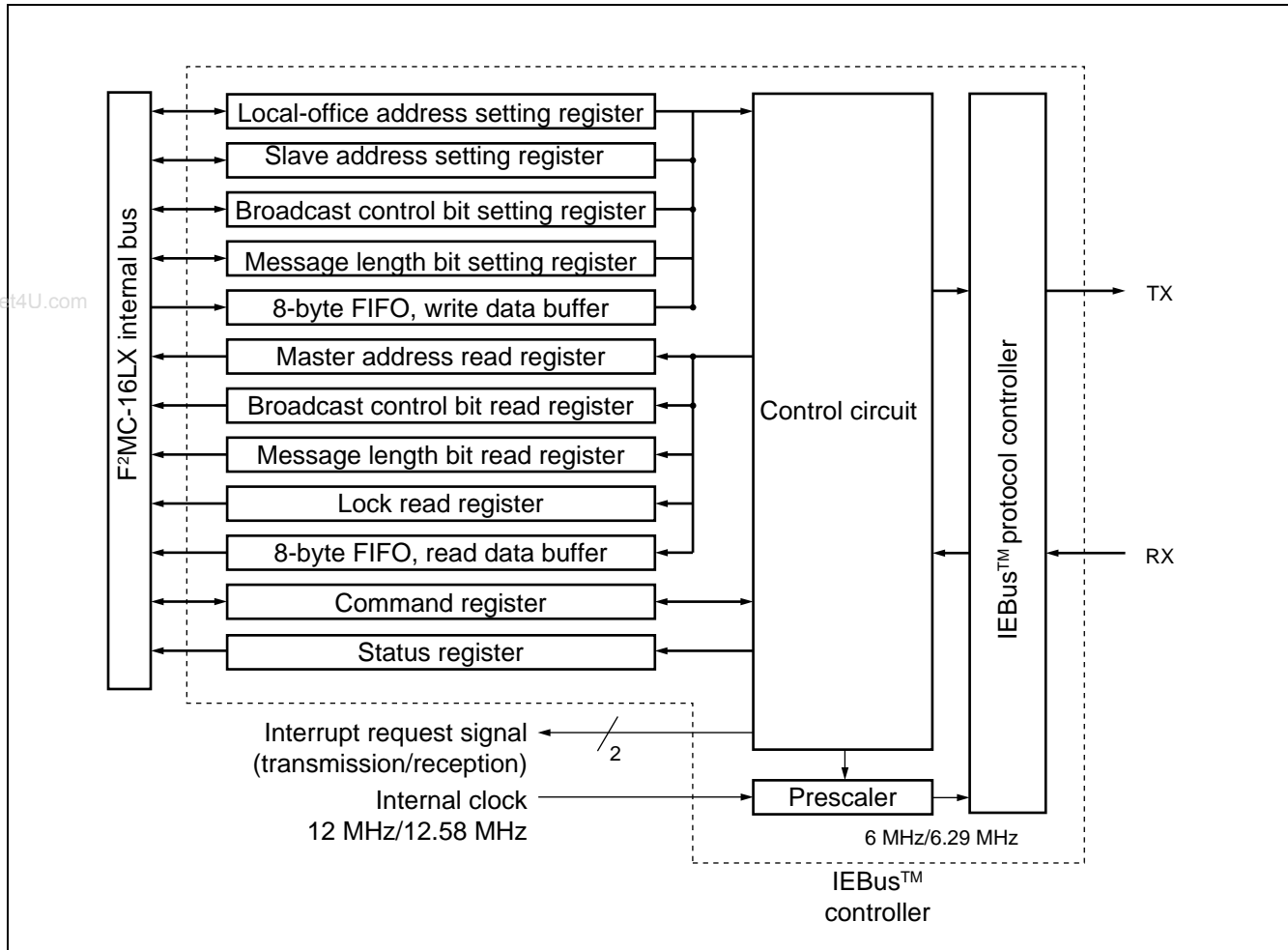

The control circuit in the IEBus™ controller executes the following control functions:

- Controls the number of bytes in data to be transmitted and received.
- Controls the maximum number of bytes transmitted.
- Detects the results of arbitration.
- Evaluates the return of acknowledgment of each field.
- Generates interrupt signals.

17. Clock Monitor Function

The clock monitor function outputs the frequency-divided machine clock signal (for monitoring purposes) from the CKOT pin.

(1) Register configuration

- Clock output enable register

bit	7	6	5	4	3	2	1	0	
Address	: 00003EH								CLKR
	—	—	—	—	CKEN	FRQ2	FRQ1	FRQ0	
Access	(—)	(—)	(—)	(—)	(R/W)	(R/W)	(R/W)	(R/W)	
Initial value	(—)	(—)	(—)	(—)	(0)	(0)	(0)	(0)	

www.DataSheet4U.com

(2) Block Diagram

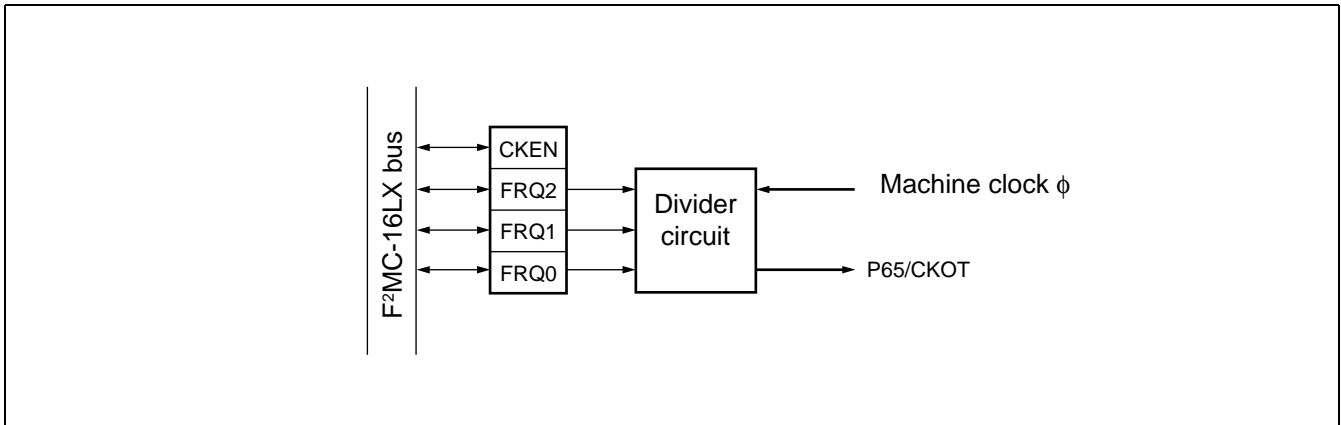

MB90580B Series

18. Address Match Detection Function

When an address matches the value set in the address detection register, the instruction code to be loaded into the CPU is forced to be replaced with the INT9 instruction code (01H). When executing a set instruction, the CPU executes the INT9 instruction. The address match detection function is implemented by processing using the INT9 interrupt routine.

The device contains two address detection registers, each provided with a compare enable bit. When the value set in the address detection register matches an address and the interrupt enable bit is "1", the instruction code to be loaded into the CPU is forced to be replaced with the INT9 instruction code.

www.DataSheet (1) Register configuration

- Program address detection register 0 to 2 (PADR0)

		bit	7	6	5	4	3	2	1	0
PADR0 (lower)	Address	:	001FF0 _H							
	Access		(R/W)	(R/W)	(R/W)	(R/W)	(R/W)	(R/W)	(R/W)	(R/W)
	Initial value		(X)	(X)	(X)	(X)	(X)	(X)	(X)	(X)

		bit	17	16	15	14	13	12	11	10
PADR0 (middle)	Address	:	001FF1 _H							
	Access		(R/W)	(R/W)	(R/W)	(R/W)	(R/W)	(R/W)	(R/W)	(R/W)
	Initial value		(X)	(X)	(X)	(X)	(X)	(X)	(X)	(X)

		bit	7	6	5	4	3	2	1	0
PADR0 (upper)	Address	:	001FF2 _H							
	Access		(R/W)	(R/W)	(R/W)	(R/W)	(R/W)	(R/W)	(R/W)	(R/W)
	Initial value		(X)	(X)	(X)	(X)	(X)	(X)	(X)	(X)

- Program address detection register 3 to 5 (PADR1)

		bit	17	16	15	14	13	12	11	10
PADR1 (lower)	Address	:	001FF3 _H							
	Access		(R/W)	(R/W)	(R/W)	(R/W)	(R/W)	(R/W)	(R/W)	(R/W)
	Initial value		(X)	(X)	(X)	(X)	(X)	(X)	(X)	(X)

		bit	7	6	5	4	3	2	1	0
PADR1 (middle)	Address	:	001FF4 _H							
	Access		(R/W)	(R/W)	(R/W)	(R/W)	(R/W)	(R/W)	(R/W)	(R/W)
	Initial value		(X)	(X)	(X)	(X)	(X)	(X)	(X)	(X)

		bit	17	16	15	14	13	12	11	10
PADR1 (upper)	Address	:	001FF5 _H							
	Access		(R/W)	(R/W)	(R/W)	(R/W)	(R/W)	(R/W)	(R/W)	(R/W)
	Initial value		(X)	(X)	(X)	(X)	(X)	(X)	(X)	(X)

- Program address detection control/status register (PACSR)

		bit	7	6	5	4	3	2	1	0
Address	:		00009E _H							
	Access		Re-served	Re-served	Re-served	Re-served	AD1E	Re-served	AD0E	Re-served
	Initial value		(-)	(-)	(-)	(-)	(R/W)	(-)	(R/W)	(-)
			(0)	(0)	(0)	(0)	(0)	(0)	(0)	(0)

(2) Block Diagram

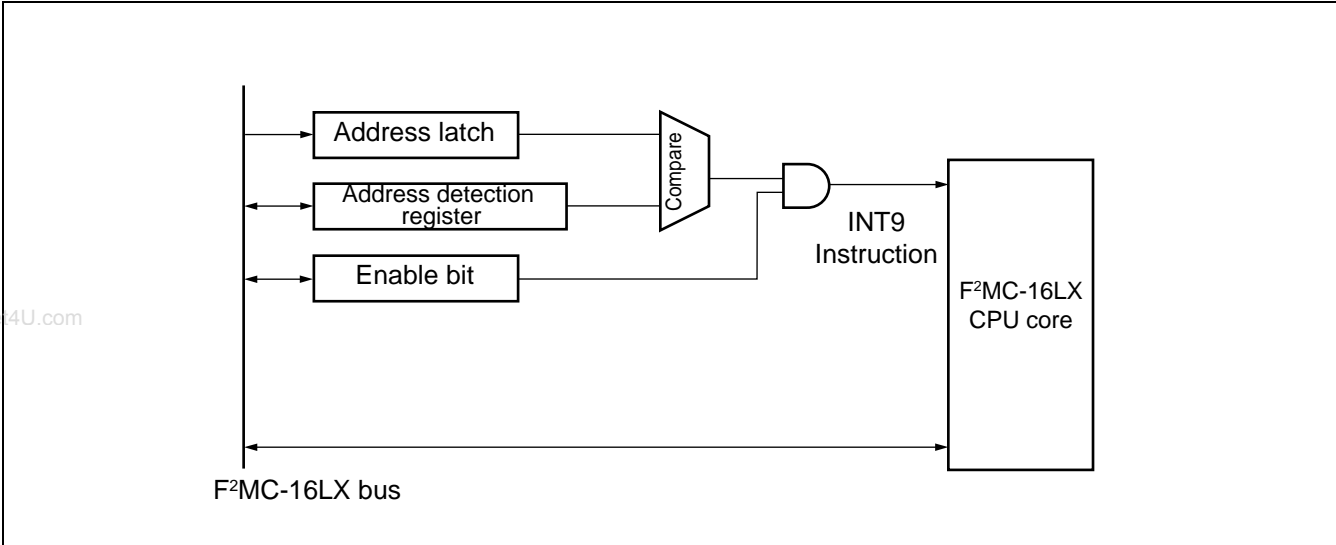

MB90580B Series

19. ROM Mirroring Function Selection Module

The ROM mirroring function selection module can select what the FF bank allocated the ROM sees through the 00 bank according to register settings.

(1) Register configuration

- ROM mirroring function selection register

bit	15	14	13	12	11	10	9	8	...
Address	—	—	—	—	—	—	—	MI	ROMM
Access	(←)	(←)	(←)	(←)	(←)	(←)	(←)	(W)	

www.DataSheet4U.com

(2) Block Diagram

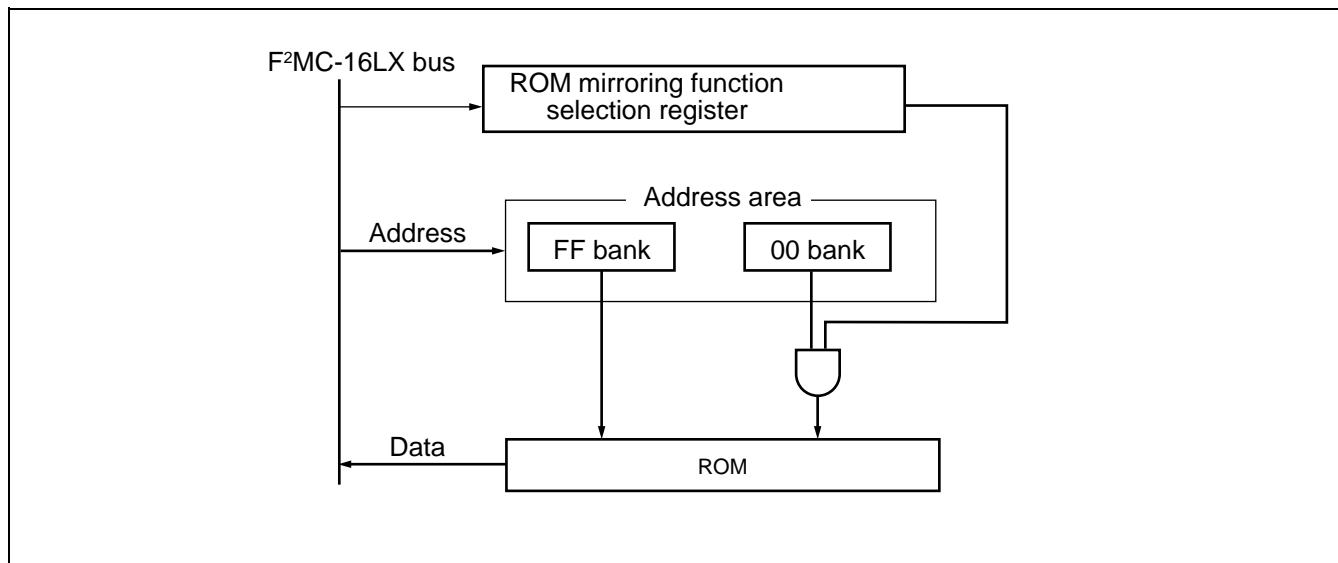

20. One-Megabit Flash Memory

The 1Mbit flash memory is allocated in the FE_H to FF_H banks on the CPU memory map. Like masked ROM, flash memory is read-accessible and program-accessible to the CPU using the flash memory interface circuit. The flash memory can be programmed/erased by the instruction from the CPU via the flash memory interface circuit. The flash memory can therefore be reprogrammed (updated) while still on the circuit board under integrated CPU control, allowing program code and data to be improved efficiently. Note that sector operations such as “enable sector protect” cannot be used.

Features of 1Mbit flash memory

- 128K words x 8 bits or 64K words x 16 bits (16K + 512 x 2 + 7K + 8K + 32K + 64K) sector configuration
- Automatic program algorithm (Embedded Algorithm*: Same as the MBM29F400TA)
- Erasure suspend/resume function integrated
- Detection of programming/erasure completion using the data polling or toggle bit
- Detection of programming/erasure completion using CPU interrupts
- Compatible with JEDEC standard commands
- Capable of erasing data sector by sector (arbitrary combination of sectors)
- Minimum number of times of programming/erasure: 100,000

* : Embedded Algorithm is a trademark of Advanced Micro Devices, Inc.

(1) Register configuration

- Flash memory control status register

		bit								
		7	6	5	4	3	2	1	0	
Address	: 0000AE _H	INTE	RDY-INT	WE	RDY	Reserved	LPM1	Reserved	LPM0	FMCS
Access		(R/W)	(R/W)	(R/W)	(R)	(W)	(R/W)	(W)	(R/W)	
Initial value		(0)	(0)	(0)	(X)	(0)	(0)	(0)	(0)	

MB90580B Series

(2) Sector configuration of 1Mbit flash memory

The 1Mbit flash memory has the sector configuration illustrated below. The addresses in the illustration are the upper and lower addresses of each sector.

When accessed from the CPU, SA0 and SA1 to SA4 are allocated in the FE and FF bank registers, respectively.

Flash memory	CPU address	Programmer address *
SA4 (16 Kbytes)	FFFFFF _H	7FFFF _H
	FFC000 _H	7C000 _H
SA3 (8 Kbytes)	FFBFFF _H	7BFFF _H
	FFA000 _H	7A000 _H
SA2 (8 Kbytes)	FF9FFF _H	79FFF _H
	FF8000 _H	78000 _H
SA1 (32 Kbytes)	FF7FFF _H	77FFF _H
	FF0000 _H	70000 _H
SA0 (64 Kbytes)	FEFFFF _H	6FFFF _H
	FE0000 _H	60000 _H

* : Programmer addresses correspond to CPU addresses when data is programmed in flash memory by a parallel programmer. Programmer addresses are used to program/erase data using a general-purpose programmer.

21. Low-Power Consumption Control Circuit

The operation modes of the MB90580B series are the PLL clock, PLL sleep, watch, main clock, main sleep, stop, and hardware standby modes. The operation modes excluding the PLL clock mode are classified as low-power consumption modes.

The low power consumption circuit has the following functions.

- Main clock mode/Main sleep mode

In either mode, the microcontroller operates only with the main clock (OSC oscillation clock), using the main clock as the operating clock while suspending the PLL clock (VCO oscillation clock).

- PLL sleep mode/Main sleep mode

These modes stop only the operation clock of the CPU, leaving the other clocks active.

- Watch mode

The watch mode allows only the time-base timer to operate.

- Stop mode/Hardware standby mode

These modes stop oscillation while retaining data at the lowest power consumption. The CPU intermittent operation function causes the clock supplied to the CPU to operate intermittently when the CPU accesses a register, internal memory, internal resource, or external bus. This function saves power consumption by decreasing the execution speed of the CPU while providing high-speed clock signals to the internal resources. The PLL clock multiplication factor can be selected from among 1, 2, 3, and 4 using the CS1 and CS0 bits in the clock selection register.

The WS1 and WS0 bits can be used to set the oscillation settling time for the main clock, which is taken to wake up from the stop or hardware standby mode.

(1) Register configuration

- Low-power consumption mode control register

		bit								
		7	6	5	4	3	2	1	0	
Address	: 0000A0 _H	STP	SLP	SPL	RST	TMD	CG1	CG0	—	LPMCR
Access		(W)	(W)	(R/W)	(W)	(—)	(R/W)	(R/W)	(—)	
Initial value		(0)	(0)	(0)	(1)	(1)	(0)	(0)	(—)	

- Clock selection register

		bit								
		15	14	13	12	11	10	9	8	
Address	: 0000A1 _H	SCM	MCM	WS1	WS0	SCS	MCS	CS1	CS0	CKSCR
Access		(R)	(R)	(R/W)	(R/W)	(R/W)	(R/W)	(R/W)	(R/W)	
Initial value		(1)	(1)	(1)	(1)	(1)	(1)	(0)	(0)	

MB90580B Series

(2) Block Diagram

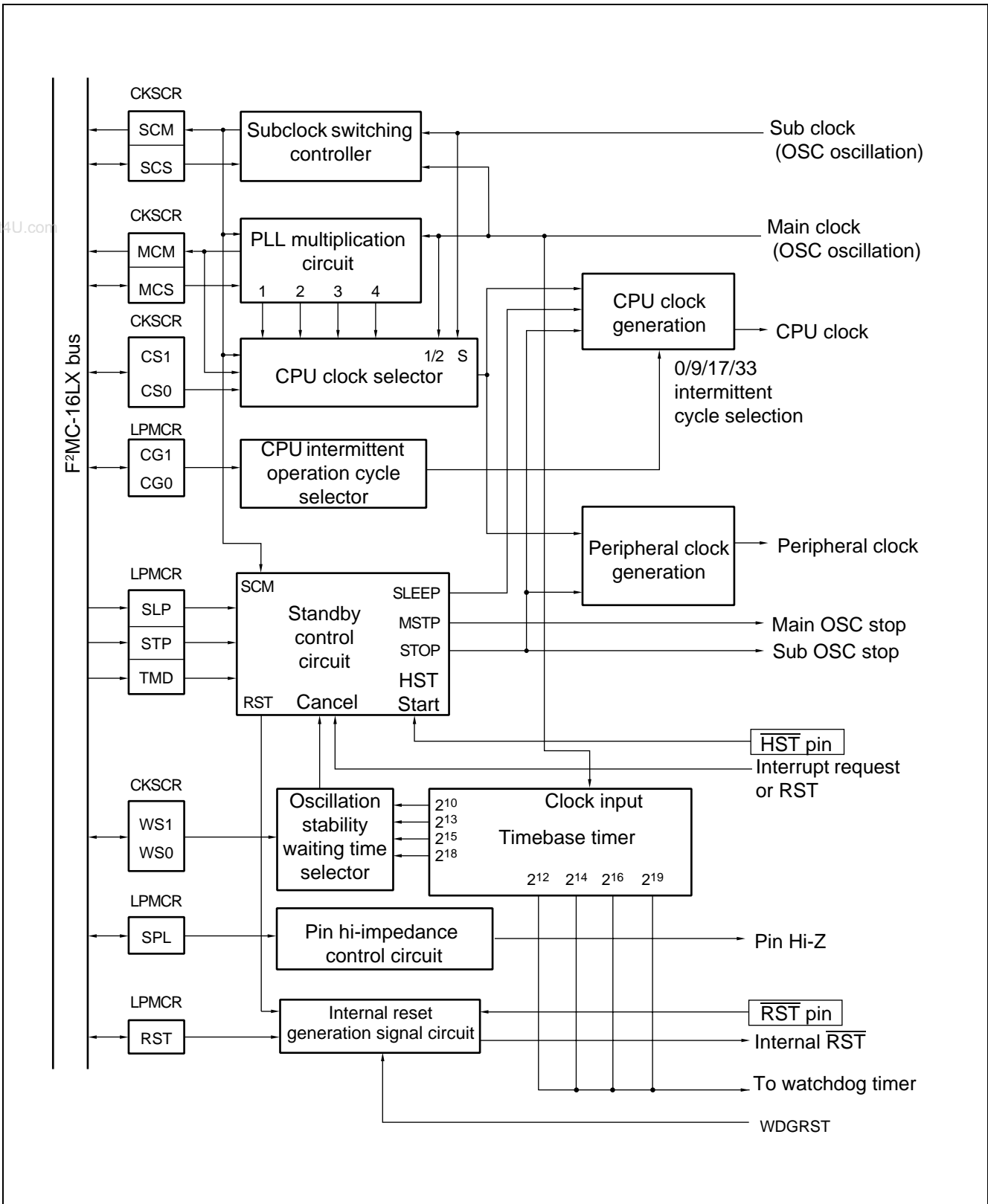

■ ELECTRICAL CHARACTERISTICS

1. Absolute Maximum Ratings

($V_{SS} = AV_{SS} = 0.0\text{ V}$)

Parameter	Symbol	Rating		Unit	Remarks
		Min.	Max.		
Power supply voltage	V_{CC}	$V_{SS} - 0.3$	$V_{SS} + 6.0$	V	
	AV_{CC}	$V_{SS} - 0.3$	$V_{SS} + 6.0$	V	$V_{CC} \geq AV_{CC}$ *1
	AVRH, AVRL	$V_{SS} - 0.3$	$V_{SS} + 6.0$	V	$AV_{CC} \geq AVRH/L$, $AVRH \geq AVRL$
	DV_{CC}	$V_{SS} - 0.3$	$V_{SS} + 6.0$	V	$V_{CC} \geq DV_{CC}$
Input voltage	V_I	$V_{SS} - 0.3$	$V_{SS} + 6.0$	V	*2
Output voltage	V_O	$V_{SS} - 0.3$	$V_{SS} + 6.0$	V	*2
"L" level maximum output current	I_{OL}	—	15	mA	*3
"L" level average output current	I_{OLAV}	—	4	mA	Average output current = operating current \times operating efficiency
"L" level total maximum output current	ΣI_{OL}	—	100	mA	
"L" level total average output current	ΣI_{OLAV}	—	50	mA	Average output current = operating current \times operating efficiency
"H" level maximum output current	I_{OH}	—	-15	mA	*3
"H" level average output current	I_{OHAV}	—	-4	mA	Average output current = operating current \times operating efficiency
"H" level total maximum output current	ΣI_{OH}	—	-100	mA	
"H" level total average output current	ΣI_{OHAV}	—	-50	mA	Average output current = operating current \times operating efficiency
Power consumption	P_D	—	300	mW	
Operating temperature	T_A	-40	+85	°C	
Storage temperature	T_{stg}	-55	+150	°C	

*1 : AV_{CC} shall never exceed V_{CC} when power on.

*2 : V_I and V_O shall never exceed $V_{CC} + 0.3\text{ V}$.

*3 : The maximum output current is a peak value for a corresponding pin.

WARNING: Semiconductor devices can be permanently damaged by application of stress (voltage, current, temperature, etc.) in excess of absolute maximum ratings. Do not exceed these ratings.

MB90580B Series

2. Recommended Operating Conditions

($V_{SS} = AV_{SS} = 0.0\text{ V}$)

Parameter	Symbol	Value		Unit	Remarks
		Min.	Max.		
Power supply voltage	V_{CC}	3.0	5.5	V	Normal operation (MB90583B, MB90587, MB90V580)
		4.5	5.5	V	Normal operation (MB90F583B)
	V_{CC}	3.0	5.5	V	Retains status at the time of operation stop
"H" level input voltage	V_{IH}	$0.7 V_{CC}$	$V_{CC}+0.3$	V	CMOS input pin
	V_{IHS}	$0.8 V_{CC}$	$V_{CC}+0.3$	V	CMOS hysteresis input pin
	V_{IHM}	$V_{CC} - 0.3$	$V_{CC}+0.3$	V	MD pin input
"L" level input voltage	V_{IL}	$V_{SS} - 0.3$	$0.3 V_{CC}$	V	CMOS input pin
	V_{ILS}	$V_{SS} - 0.3$	$0.2 V_{CC}$	V	CMOS hysteresis input pin
	V_{ILM}	$V_{SS} - 0.3$	$V_{SS}+0.3$	V	MD pin input
Smoothing capacitor	C_s	0.1	1.0	μF	Use a ceramic capacitor or a capacitor with equivalent frequency characteristics. The smoothing capacitor to be connected to the V_{CC} pin must have a capacitance value higher than C_s .
Operating temperature	T_A	-40	+85	$^{\circ}\text{C}$	

• C pin connection circuit

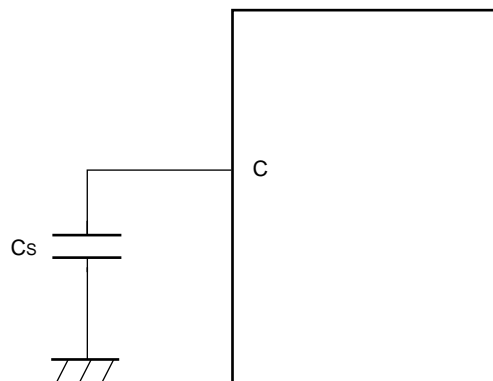

WARNING: The recommended operating conditions are required in order to ensure the normal operation of the semiconductor device. All of the device's electrical characteristics are warranted when the device is operated within these ranges.

Always use semiconductor devices within their recommended operating condition ranges. Operation outside these ranges may adversely affect reliability and could result in device failure.

No warranty is made with respect to uses, operating conditions, or combinations not represented on the data sheet. Users considering application outside the listed conditions are advised to contact their FUJITSU representatives beforehand.

MB90580B Series

3. DC Characteristics

($V_{CC} = 5.0\text{ V} \pm 10\%$, $V_{SS} = AV_{SS} = 0.0\text{ V}$, $T_A = -40\text{ }^\circ\text{C}$ to $+85\text{ }^\circ\text{C}$)

Parameter	Symbol	Pin name	Condition	Value			Unit	Remarks
				Min.	Typ.	Max.		
"H" level output voltage	V_{OH}	All output pins	$V_{CC} = 4.5\text{ V}$, $I_{OH} = -2.0\text{ mA}$	$V_{CC} - 0.5$	—	—	V	
"L" level output voltage	V_{OL}	All output pins	$V_{CC} = 4.5\text{ V}$, $I_{OL} = 2.0\text{ mA}$	—	—	0.4	V	
Input leakage current	I_{IL}	All input pins	$V_{CC} = 5.5\text{ V}$, $V_{SS} < V_I < V_{CC}$	-5	—	5	μA	
Power supply current*	I_{CC}	V_{CC}	$V_{CC} = 5.0\text{ V}$, Internal operation at 16 MHz, Normal operation	—	27	33	mA	MB90583B, MB90587
			$V_{CC} = 5.0\text{ V}$, Internal operation at 12.58 MHz, Normal operation	—	40	50	mA	MB90F583B
			$V_{CC} = 5.0\text{ V}$, Internal operation at 12.58 MHz, Normal operation	—	22	26	mA	MB90583B
			$V_{CC} = 5.0\text{ V}$, Internal operation at 12.58 MHz, Normal operation	—	35	45	mA	MB90F583B
			$V_{CC} = 5.0\text{ V}$, Internal operation at 16 MHz, When data written in flash mode pro- gramming of erasing	—	45	60	mA	MB90F583B
			$V_{CC} = 5.0\text{ V}$, Internal operation at 12.58 MHz, When data written in flash mode pro- gramming of erasing	—	40	50	mA	
	I_{CCS}		$V_{CC} = 5.0\text{ V}$, Internal operation at 16 MHz, , In sleep mode	—	7	12	mA	MB90587
			$V_{CC} = 5.0\text{ V}$, Internal operation at 16 MHz, , In sleep mode	—	15	20	mA	MB90583B, MB90F583B
			$V_{CC} = 5.0\text{ V}$, Internal operation at 12.58 MHz, In sleep mode	—	6	10	mA	MB90587
			$V_{CC} = 5.0\text{ V}$, Internal operation at 12.58 MHz, In sleep mode	—	12	18	mA	MB90583B, MB90F583B
	I_{CCL}		$V_{CC} = 5.0\text{ V}$, Internal operation at 8 kHz, Subsystem opera- tion, $T_A = 25\text{ }^\circ\text{C}$	—	0.1	1.0	mA	MB90583B, MB90587
			$V_{CC} = 5.0\text{ V}$, Internal operation at 8 kHz, Subsystem opera- tion, $T_A = 25\text{ }^\circ\text{C}$	—	4	7	mA	MB90F583B

(Continued)

MB90580B Series

(Continued)

($V_{CC} = 5.0\text{ V} \pm 10\%$, $V_{SS} = AV_{SS} = 0.0\text{ V}$, $T_A = -40\text{ }^\circ\text{C}$ to $+85\text{ }^\circ\text{C}$)

Parameter	Symbol	Pin name	Condition	Value			Unit	Remarks
				Min.	Typ.	Max.		
Power supply current*	I _{CCLS}	V _{CC}	V _{CC} = 5.0 V, Internal operation at 8 kHz, In subsleep mode, T _A = 25 °C	—	30	50	μA	MB90583B, MB90587, MB90F583
	I _{CCCT}		V _{CC} = 5.0 V, Internal operation at 8 kHz, In clock mode, T _A = 25 °C	—	15	30	μA	MB90583B, MB90587, MB90F583B
	I _{CCCH}		In stop mode, T _A = 25 °C	—	5	20	μA	MB90583B MB90587, MB90F583B
Input capacitance	C _{IN}	Except AV _{CC} , AV _{SS} , C, V _{CC} and V _{SS}	—	—	10	80	pF	
Open-drain output leakage current	I _{leak}	P40 to P47	—	—	0.1	5	μA	Open-drain output setting
Pull-up resistance	R _{UP}	P00 to P07 P10 to P17 P60 to P65 RST	—	25	50	100	kΩ	
Pull-down resistance	R _{DOWN}	MD2	—	25	50	100	kΩ	

* The current value is preliminary value and may be subject to change for enhanced characteristics without previous notice. The power supply current is measured with an external clock.

4. AC Characteristics

(1) Clock Timings

($V_{CC} = 5.0\text{ V} \pm 10\%$, $V_{SS} = AV_{SS} = 0.0\text{ V}$, $T_A = -40\text{ }^\circ\text{C}$ to $+85\text{ }^\circ\text{C}$)

Parameter	Symbol	Pin name	Condition	Value			Unit	Remarks
				Min.	Typ.	Max.		
Clock frequency	f_c	X0, X1	—	3	—	16	MHz	
	f_{CL}	X0A, X1A		—	32.768	—	kHz	
Clock cycle time	t_{HCYL}	X0, X1		62.5	—	333	ns	
	t_{LCYL}	X0A, X1A		—	30.5	—	μs	
Frequency fluctuation rate locked*	Δf	—		—	—	5	%	
Input clock pulse width	P_{WH} P_{WL}	X0		10	—	—	ns	Recommended duty ratio of 30% to 70%
	P_{WLH} P_{WLL}	X0A		—	15.2	—	μs	
Input clock rise/fall time	t_{CR} t_{CF}	X0		—	—	5	ns	External clock operation
	Internal operating clock frequency	f_{CP}		—	1.5	—	16	MHz
f_{LCP}		—		—	8.192	—	kHz	Subclock operation
Internal operating clock cycle time	t_{CP}	—		62.5	—	666	ns	Main clock operation
	t_{LCP}	—		—	122.1	—	μs	Subclock operation

*: The frequency fluctuation rate is the maximum deviation rate of the preset center frequency when the multiplied PLL signal is locked.

$$\Delta f = \frac{|\alpha|}{f_0} \times 100 (\%)$$

Center frequency

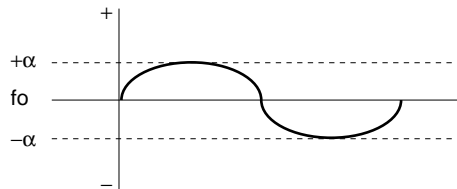

• X0, X1 clock timing

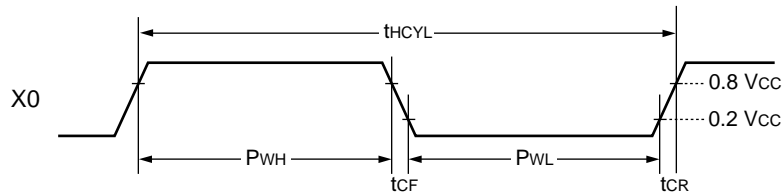

• X0A, X1A clock timing

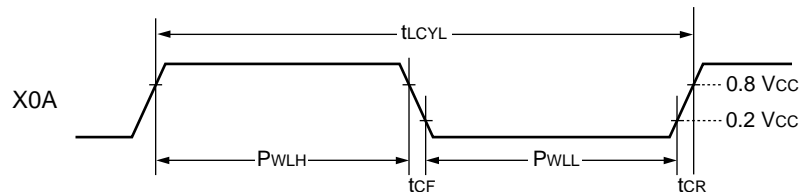

MB90580B Series

- PLL operation guarantee range

Relationship between internal operating clock frequency and power supply voltage

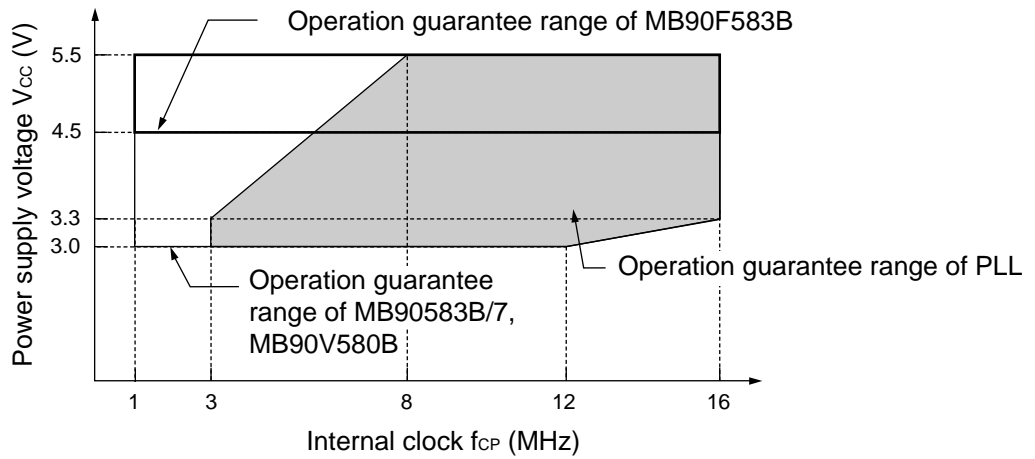

Relationship between oscillating frequency and internal operating clock frequency

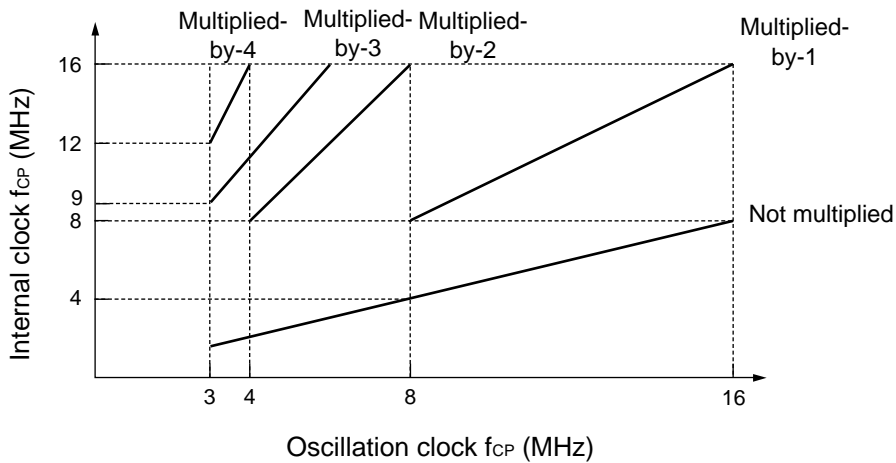

The AC ratings are measured for the following measurement reference voltages

- Input signal waveform

Hysteresis input pin

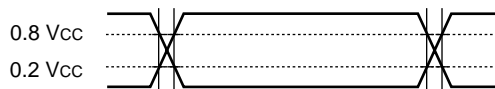

Pins other than hysteresis input/MD input

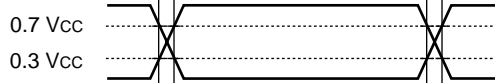

- Output signal waveform

Output pin

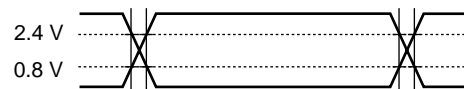

(2) Clock Output Timings

($V_{CC} = 5.0\text{ V} \pm 10\%$, $V_{SS} = AV_{SS} = 0.0\text{ V}$, $T_A = -40\text{ }^\circ\text{C}$ to $+85\text{ }^\circ\text{C}$)

Parameter	Symbol	Pin name	Condition	Value		Unit	Remarks
				Min.	Max.		
Clock cycle time	t_{CYC}	CLK	$V_{CC} = 5\text{ V} \pm 10\%$	62.5	—	ns	
CLK \uparrow \rightarrow CLK \downarrow	t_{CHCL}			20	—	ns	

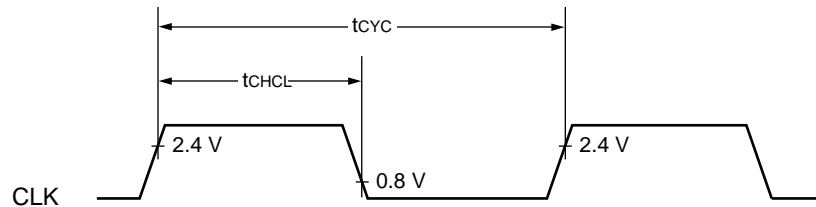

(3) Reset, Hardware Standby Input Timing

($V_{CC} = 5.0\text{ V} \pm 10\%$, $V_{SS} = AV_{SS} = 0.0\text{ V}$, $T_A = -40\text{ }^\circ\text{C}$ to $+85\text{ }^\circ\text{C}$)

Parameter	Symbol	Pin name	Condition	Value		Unit	Remarks
				Min.	Max.		
Reset input time	t_{RSTL}	$\overline{\text{RST}}$	—	$4 t_{CP}$	—	ns	
Hardware standby input time	t_{HSTL}	$\overline{\text{HST}}$		$4 t_{CP}$	—	ns	

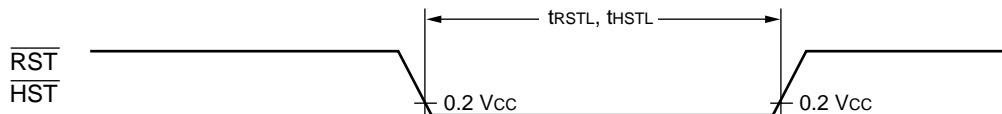

MB90580B Series

(4) Power-on Reset

($V_{CC} = 5.0\text{ V} \pm 10\%$, $V_{SS} = AV_{SS} = 0.0\text{ V}$, $T_A = -40\text{ }^\circ\text{C}$ to $+85\text{ }^\circ\text{C}$)

Parameter	Symbol	Pin name	Condition	Value		Unit	Remarks
				Min.	Max.		
Power supply rising time	t_R	V_{CC}	—	0.05	30	ms	
Power supply cut-off time	t_{OFF}	V_{CC}	—	4	—	ms	Due to repeated operations

Note : - V_{CC} must be kept lower than 0.2 V before power-on.

www.DataSheet4U.com - The above values are used for causing a power-on reset.

- If $\overline{HST} = "L"$, be sure to turn the power supply on using the above values to cause a power-on reset whether or not the power-on reset is required.
- Some registers in the device are initialized only upon a power-on reset. To initialize these registers, turn the power supply using the above values.

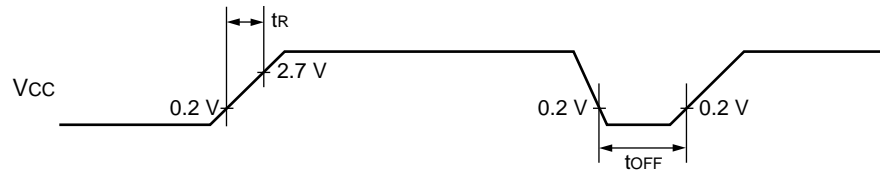

Sudden changes in the power supply voltage may cause a power-on reset. To change the power supply voltage while the device is in operation, it is recommended to raise the voltage smoothly to suppress fluctuations as shown below. In this case, change the supply voltage with the PLL clock not used. If the voltage drop is 1 mV or fewer per second, however, you can use the PLL clock.

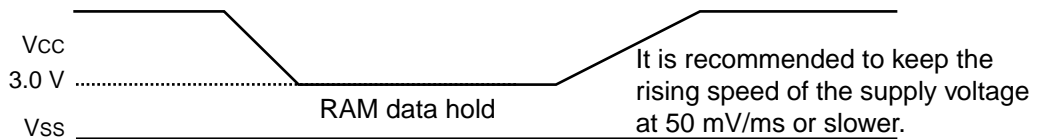

MB90580B Series

(5) Bus Timing (Read)

($V_{CC} = 5.0 V \pm 10\%$, $V_{SS} = AV_{SS} = 0.0 V$, $T_A = -40\text{ }^\circ\text{C}$ to $+85\text{ }^\circ\text{C}$)

Parameter	Symbol	Pin name	Condition	Value		Unit	Remarks
				Min.	Max.		
ALE pulse width	t_{LHLL}	ALE	—	$t_{CP}/2 - 20$	—	ns	
Effective address → ALE ↓ time	t_{AVLL}	ALE, A23 to A16, AD15 to AD00		$t_{CP}/2 - 20$	—	ns	
ALE ↓ → address effective time	t_{LLAX}	ALE, AD15 to AD00		$t_{CP}/2 - 15$	—	ns	
Effective address → \overline{RD} ↓ time	t_{AVRL}	A23 to A16, AD15 to AD00, \overline{RD}		$t_{CP} - 15$	—	ns	
Effective address → valid data input	t_{AVDV}	A23 to A16, AD15 to AD00		—	$5 t_{CP}/2 - 60$	ns	
\overline{RD} pulse width	t_{RLRH}	\overline{RD}		$3 t_{CP}/2 - 20$	—	ns	
\overline{RD} ↓ → valid data input	t_{RLDV}	\overline{RD} , AD15 to AD00		—	$3 t_{CP}/2 - 60$	ns	
\overline{RD} ↑ → data hold time	t_{RHDX}	\overline{RD} , AD15 to AD00		0	—	ns	
\overline{RD} ↑ → ALE ↑ time	t_{RHLH}	\overline{RD} , ALE		$t_{CP}/2 - 15$	—	ns	
\overline{RD} ↑ → address effective time	t_{RHAX}	ALE, A23 to A16		$t_{CP}/2 - 10$	—	ns	
Effective address → CLK ↑ time	t_{AVCH}	A23 to A16, AD15 to AD00, CLK		$t_{CP}/2 - 20$	—	ns	
\overline{RD} ↓ → CLK ↑ time	t_{RLCH}	\overline{RD} , CLK		$t_{CP}/2 - 20$	—	ns	
ALE ↓ → \overline{RD} ↓ time	t_{LLRL}	ALE, \overline{RD}		$t_{CP}/2 - 15$	—	ns	

MB90580B Series

• Bus Timing (Read)

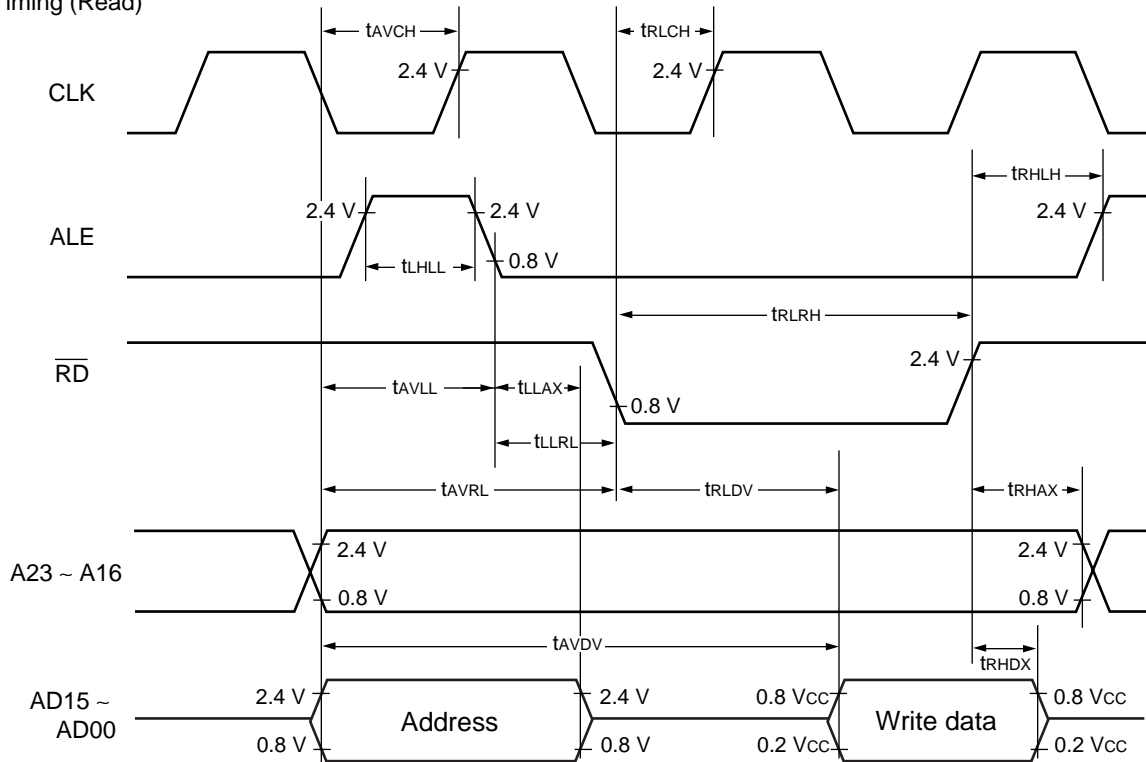

MB90580B Series

(6) Bus Timing (Write)

($V_{CC} = 5.0 V \pm 10\%$, $V_{SS} = AV_{SS} = 0.0 V$, $T_A = -40\text{ }^\circ\text{C}$ to $+85\text{ }^\circ\text{C}$)

Parameter	Symbol	Pin name	Condition	Value		Unit	Remarks
				Min.	Max.		
Effective address \rightarrow \overline{WRH} , $\overline{WRL} \downarrow$ time	t_{AVWL}	A23 to A16, AD15 to AD00, \overline{WRH} , \overline{WRL}	—	$t_{CP} - 15$	—	ns	
\overline{WRH} , \overline{WRL} pulse width	t_{WLWH}	\overline{WRH} , \overline{WRL}	—	$3 t_{CP}/2 - 20$	—	ns	
Effective data output \rightarrow \overline{WRH} , $\overline{WRL} \uparrow$ time	t_{DVWH}	AD15 to AD00, \overline{WRH} , \overline{WRL}	—	$3 t_{CP}/2 - 20$	—	ns	
\overline{WRH} , $\overline{WRL} \uparrow \rightarrow$ data hold time	t_{WHDX}	\overline{WRH} , \overline{WRL} , AD15 to AD00	—	20	—	ns	
\overline{WRH} , $\overline{WRL} \uparrow \rightarrow$ ad- dress effective time	t_{WHAX}	\overline{WRH} , \overline{WRL} , A23 to A16	—	$t_{CP}/2 - 10$	—	ns	
\overline{WRH} , $\overline{WRL} \uparrow \rightarrow$ ALE \uparrow time	t_{WHLH}	\overline{WRH} , \overline{WRL} , ALE	—	$t_{CP}/2 - 15$	—	ns	
\overline{WRH} , $\overline{WRL} \downarrow \rightarrow$ CLK \uparrow time	t_{WLCH}	\overline{WRH} , \overline{WRL} , CLK	—	$t_{CP}/2 - 20$	—	ns	

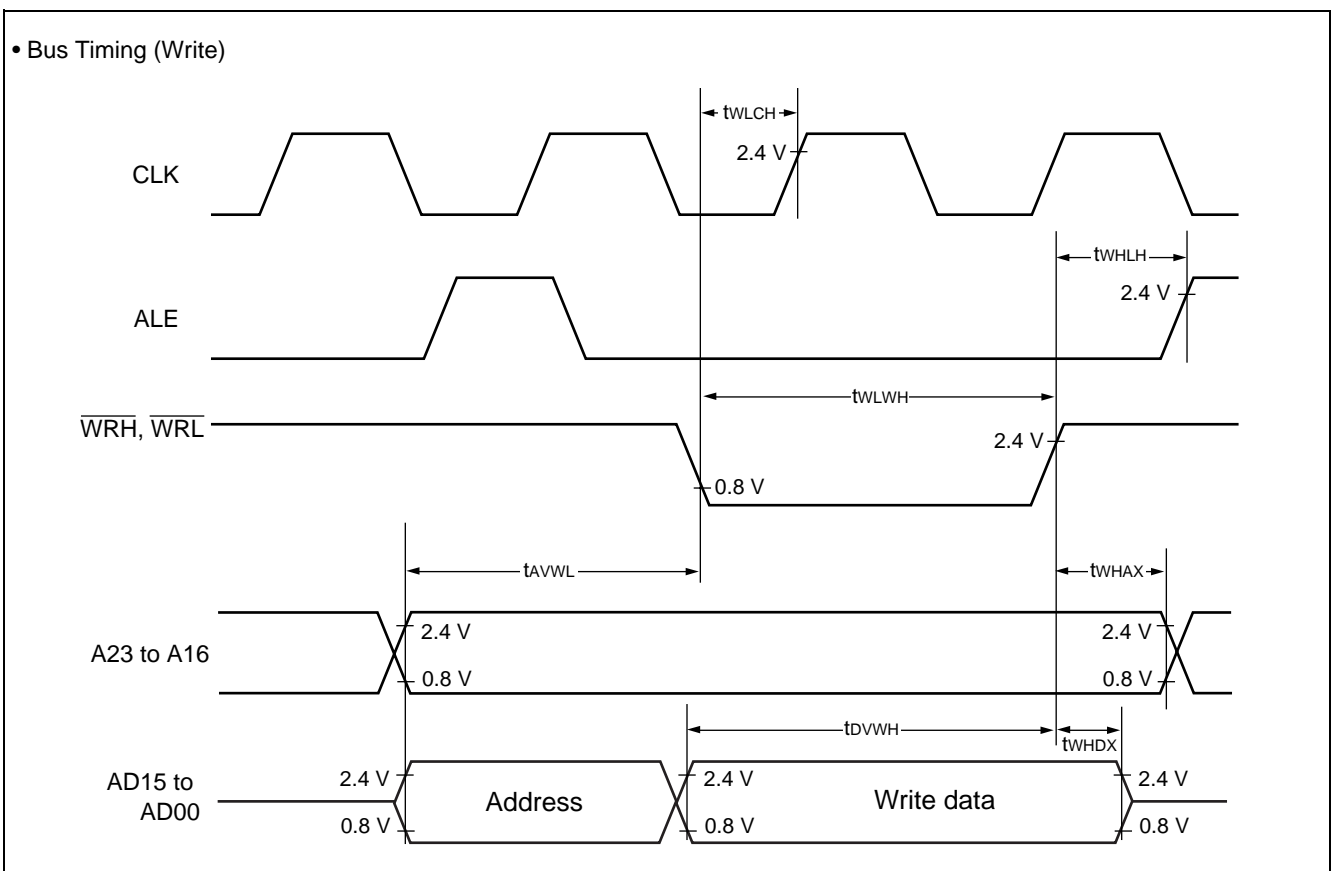

MB90580B Series

(7) Ready Input Timing

($V_{CC} = 5.0\text{ V} \pm 10\%$, $V_{SS} = AV_{SS} = 0.0\text{ V}$, $T_A = -40\text{ }^\circ\text{C}$ to $+85\text{ }^\circ\text{C}$)

Parameter	Symbol	Pin name	Condition	Value		Unit	Remarks
				Min.	Max.		
RDY setup time	t_{RYHS}	RDY	—	45	—	ns	
RDY hold time	t_{RYHH}		—	0	—	ns	

Note: Use the automatic ready function when the setup time for the rising edge of the RDY signal is not sufficient.

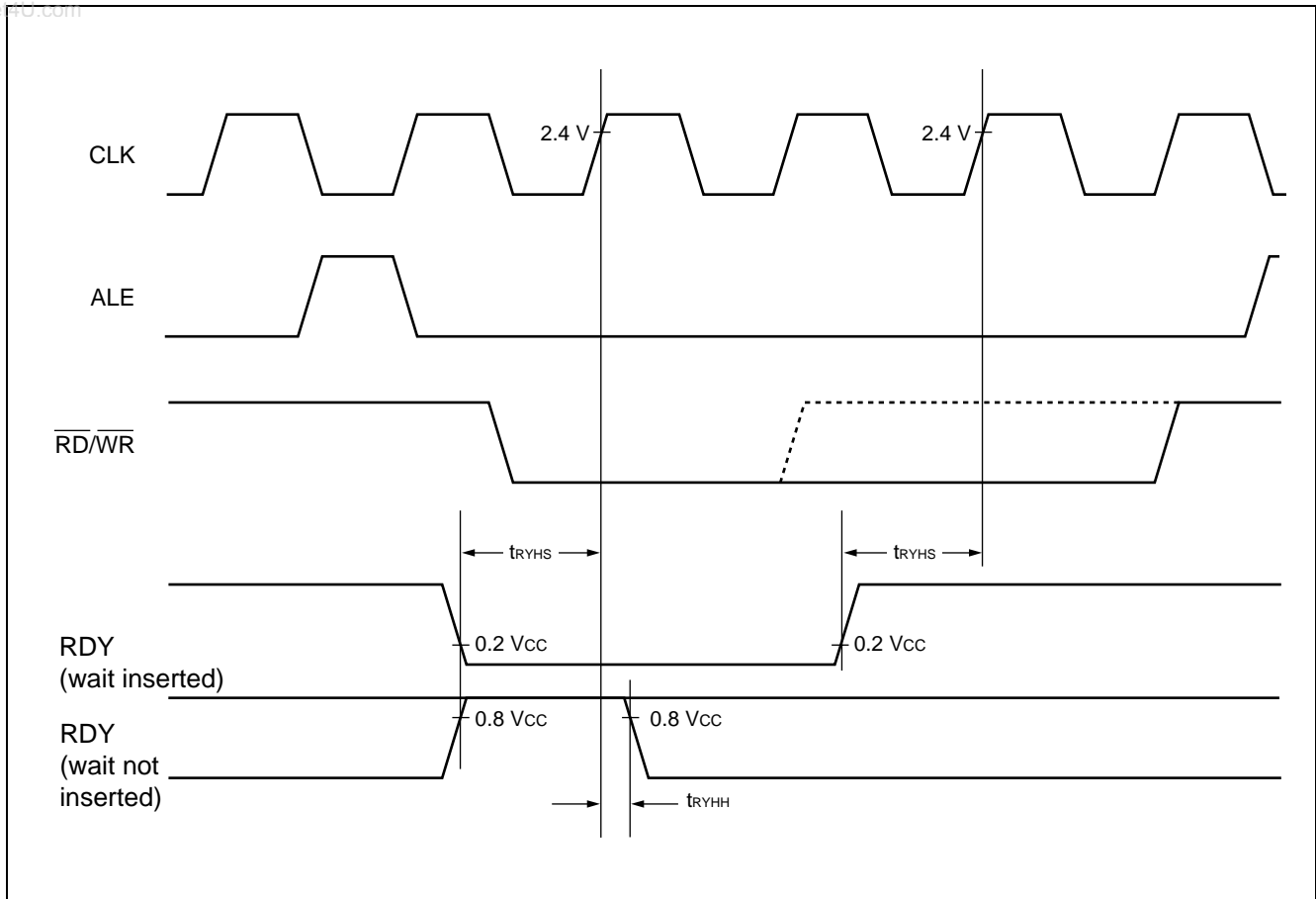

MB90580B Series

(8) Hold Timing

($V_{CC} = 5.0 V \pm 10\%$, $V_{SS} = AV_{SS} = 0.0 V$, $T_A = -40\text{ }^\circ\text{C}$ to $+85\text{ }^\circ\text{C}$)

Parameter	Symbol	Pin name	Condition	Value		Unit	Remarks
				Min.	Max.		
Pins in floating status $\rightarrow \overline{\text{HAK}} \downarrow$ time	t_{XHAL}	$\overline{\text{HAK}}$	—	30	t_{CP}	ns	
$\overline{\text{HAK}} \uparrow \rightarrow$ pin valid time	t_{HAHV}	$\overline{\text{HAK}}$	—	t_{CP}	$2 t_{CP}$	ns	

Note: More than 1 machine cycle is needed before $\overline{\text{HAK}}$ changes after HRQ pin is fetched.

www.DataSheet4U.com

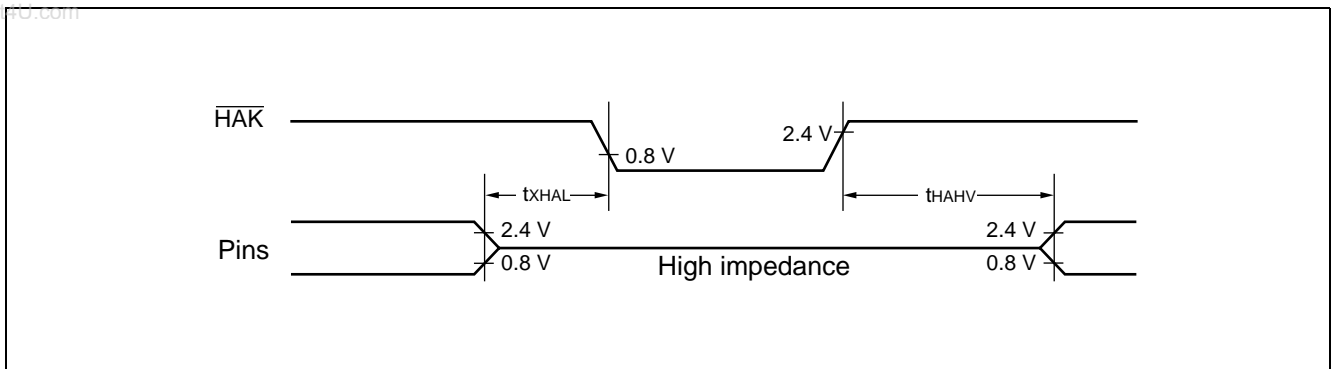

MB90580B Series

(9) UART0 to UART4

($V_{CC} = 5.0 V \pm 10\%$, $V_{SS} = AV_{SS} = 0.0 V$, $T_A = -40\text{ }^\circ\text{C}$ to $+85\text{ }^\circ\text{C}$)

Parameter	Symbol	Pin name	Condition	Value		Unit	Remarks
				Min.	Max.		
Serial clock cycle time	t_{SCYC}	SCK0 to SCK4	$C_L = 80\text{ pF} + 1\text{ TTL}$ for an output pin of internal shift clock mode	$8 t_{CP}$	—	ns	
SCK ↓ → SOT delay time	t_{SLOV}	SCK0 to SCK4, SOT0 to SOT4		-80	80	ns	
Valid SIN → SCK ↑	t_{IVSH}	SCK0 to SCK4, SIN0 to SIN4		100	—	ns	
SCK ↑ → valid SIN hold time	t_{SHIX}	SCK0 to SCK4, SIN0 to SIN4		60	—	ns	
Serial clock "H" pulse width	t_{SHSL}	SCK0 to SCK4	$C_L = 80\text{ pF} + 1\text{ TTL}$ for an output pin of external shift clock mode	$4 t_{CP}$	—	ns	
Serial clock "L" pulse width	t_{LSLH}	SCK0 to SCK4		$4 t_{CP}$	—	ns	
SCK ↓ → SOT delay time	t_{SLOV}	SCK0 to SCK4, SOT0 to SOT4		—	150	ns	
Valid SIN → SCK ↑	t_{IVSH}	SCK0 to SCK4, SIN0 to SIN4		60	—	ns	
SCK ↑ → valid SIN hold time	t_{SHIX}	SCK0 to SCK4, SIN0 to SIN4		60	—	ns	

- Note:
- These are AC ratings in the CLK synchronous mode.
 - C_L is the load capacitance value connected to pins while testing.
 - t_{CP} is machine cycle time (unit:ns).

- Internal shift clock mode

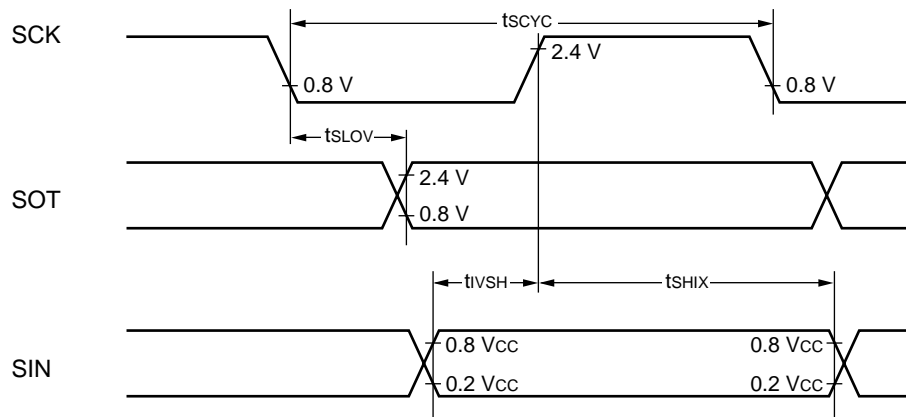

- External shift clock mode

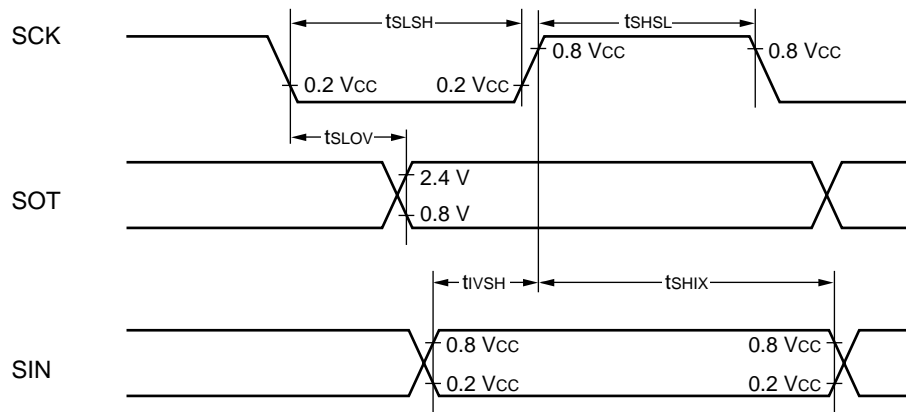

MB90580B Series

(10) Timer Input Timing

($V_{CC} = 5.0\text{ V} \pm 10\%$, $V_{SS} = AV_{SS} = 0.0\text{ V}$, $T_A = -40\text{ }^\circ\text{C}$ to $+85\text{ }^\circ\text{C}$)

Parameter	Symbol	Pin name	Condition	Value		Unit	Remarks
				Min.	Max.		
Input pulse width	t_{TIWH} t_{TIWL}	IN0 to IN3, TIN0 to TIN2	—	$4 t_{CP}$	—	ns	

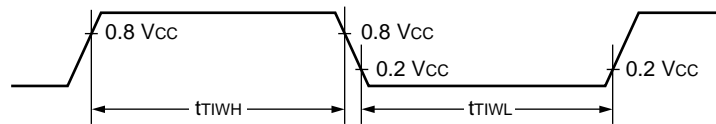

(11) Timer Output Timing

($V_{CC} = 5.0\text{ V} \pm 10\%$, $V_{SS} = AV_{SS} = 0.0\text{ V}$, $T_A = -40\text{ }^\circ\text{C}$ to $+85\text{ }^\circ\text{C}$)

Parameter	Symbol	Pin name	Condition	Value		Unit	Remarks
				Min.	Max.		
$\text{CLK} \uparrow \rightarrow T_{OUT}$ transition time	t_{TO}	OUT0, OUT1, PPG0, PPG1, TOT0 to TOT2	—	30	—	ns	

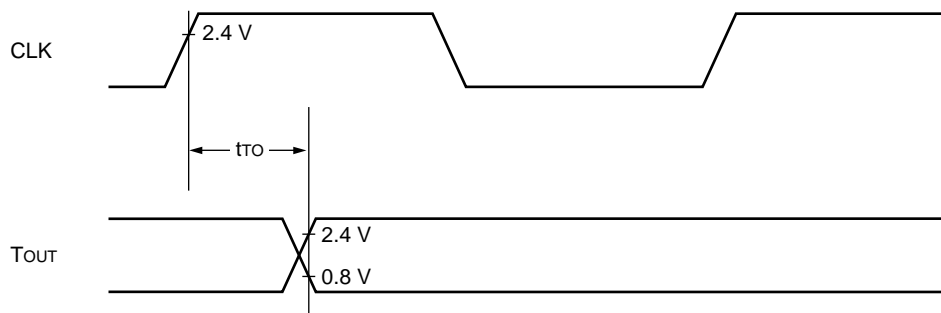

MB90580B Series

(12) Trigger Input Timing

($V_{CC} = 5.0\text{ V} \pm 10\%$, $V_{SS} = AV_{SS} = 0.0\text{ V}$, $T_A = -40\text{ }^\circ\text{C}$ to $+85\text{ }^\circ\text{C}$)

Parameter	Symbol	Pin name	Condition	Value		Unit	Remarks
				Min.	Max.		
Input pulse width	t_{TRGL}	IRQ0 to IRQ7, ADTG	—	$5 t_{CP}$	—	ns	

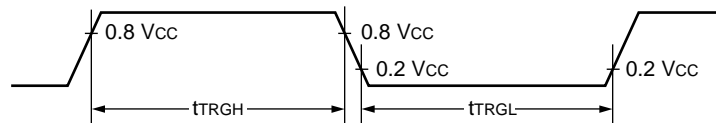

MB90580B Series

(13) IEBus™ Timing

($V_{CC} = 5.0\text{ V} \pm 10\%$, $V_{SS} = AV_{SS} = 0.0\text{ V}$, $T_A = -40\text{ }^\circ\text{C}$ to $+85\text{ }^\circ\text{C}$)

Parameter	Symbol	Pin name	Condition	Value		Unit	Remarks
				Min.	Max.		
TX → RX delay time (rise)	t_{DLY1}	TX, RX	—	0	1000	ns	
TX → RX delay time (fall)	t_{DLY2}	TX, RX		0	1000	ns	

www.DataSheet4U.com

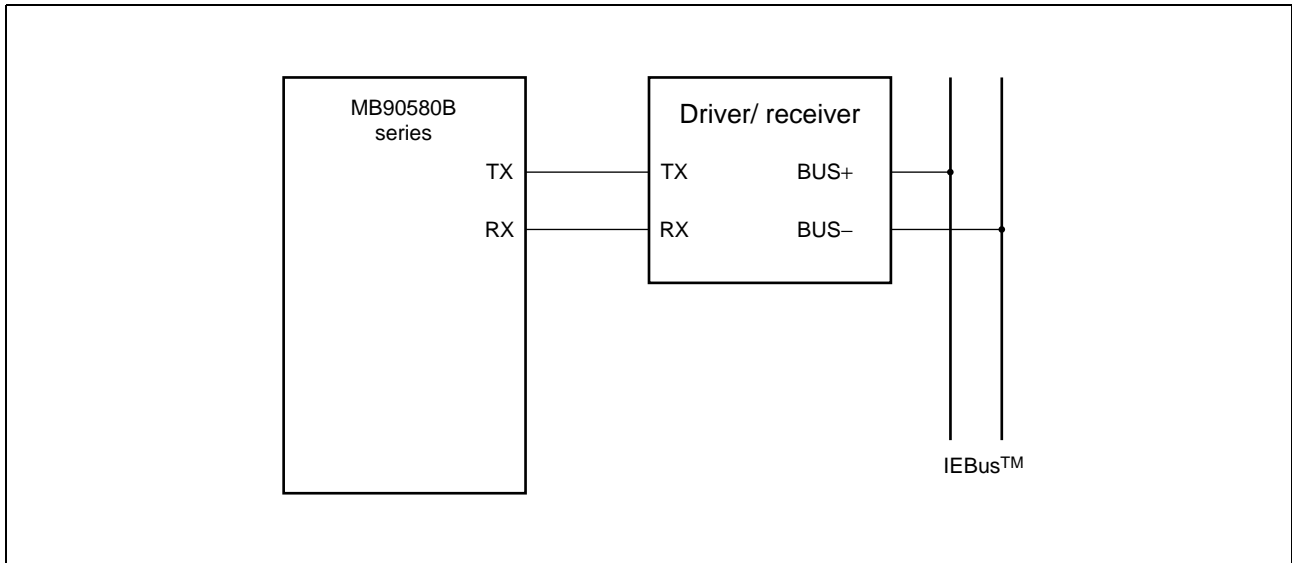
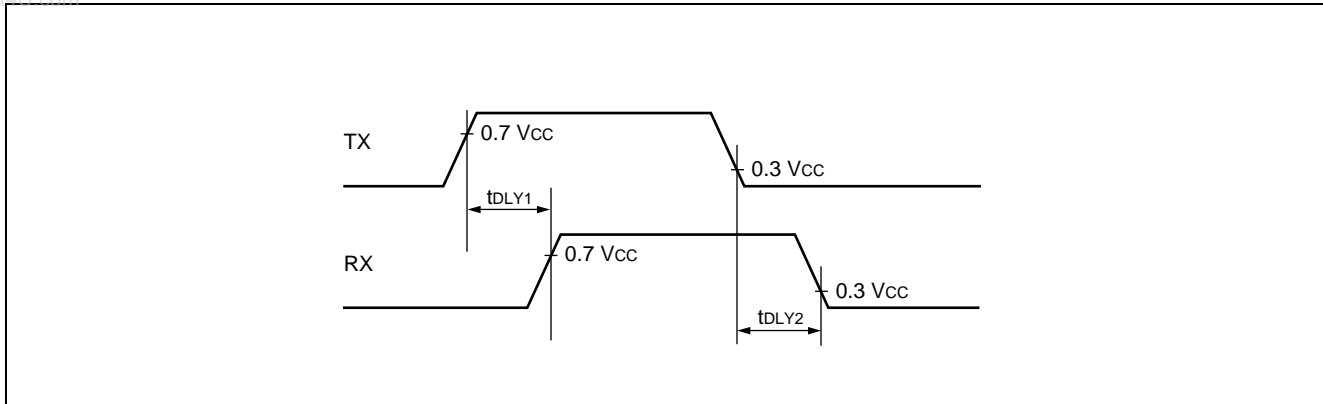

5. A/D Converter Electrical Characteristics

($3.0\text{ V} \leq \text{AVRH} - \text{AVRL}$, $V_{CC} = \text{AV}_{CC} = 5.0\text{ V} \pm 10\%$, $V_{SS} = \text{AV}_{SS} = 0.0\text{ V}$, $T_A = -40\text{ }^\circ\text{C}$ to $+85\text{ }^\circ\text{C}$)

Parameter	Symbol	Pin name	Value			Unit	Remarks
			Min.	Typ.	Max.		
Resolution	—	—	—	10	—	bit	
Total error	—	—	—	—	± 5.0	LSB	
Non-linear error	—	—	—	—	± 2.5	LSB	
Differential linearity error	—	—	—	—	± 1.9	LSB	
Zero transition voltage	V_{OT}	AN0 to AN7	$\text{AV}_{SS} - 3.5$	+0.5	$\text{AV}_{SS} + 4.5$	mV	
Full-scale transition voltage	V_{FST}	AN0 to AN7	$\text{AVRH} - 6.5$	$\text{AVRH} - 1.5$	$\text{AVRH} + 1.5$	mV	
Conversion time	—	—	—	176 t_{CP}	—	ns	
Sampling period	—	—	—	64 t_{CP}	—	ns	
Analog port input current	I_{AIN}	AN0 to AN7	—	—	10	μA	
Analog input voltage	V_{AIN}	AN0 to AN7	AVRL	—	AVRH	V	
Reference voltage	—	AVRH	$\text{AVRL} + 2.7$	—	AV_{CC}	V	
	—	AVRL	0	—	$\text{AVRH} - 2.7$	V	
Power supply current	I_A	AV_{CC}	—	5	—	mA	
	I_{AH}	AV_{CC}	—	—	5	μA	*
Reference voltage supply current	I_R	AVRH	—	400	—	μA	
	I_{RH}	AVRH	—	—	5	μA	*
Offset between channels	—	AN0 to AN7	—	—	4	LSB	

* : The current when the A/D converter is not operating or the CPU is in stop mode (for $V_{CC} = \text{AV}_{CC} = \text{AVRH} = 5.0\text{ V}$)

Note: • The error increases proportionally as $|\text{AVRH} - \text{AVRL}|$ decreases.

- The output impedance of the external circuits connected to the analog inputs should be in the following range.
- The output impedance of the external circuit : 15.5 k Ω (Max.) (Sampling time = 4.0 μs)
- If the output impedance of the external circuit is too high, the sampling time might be insufficient.

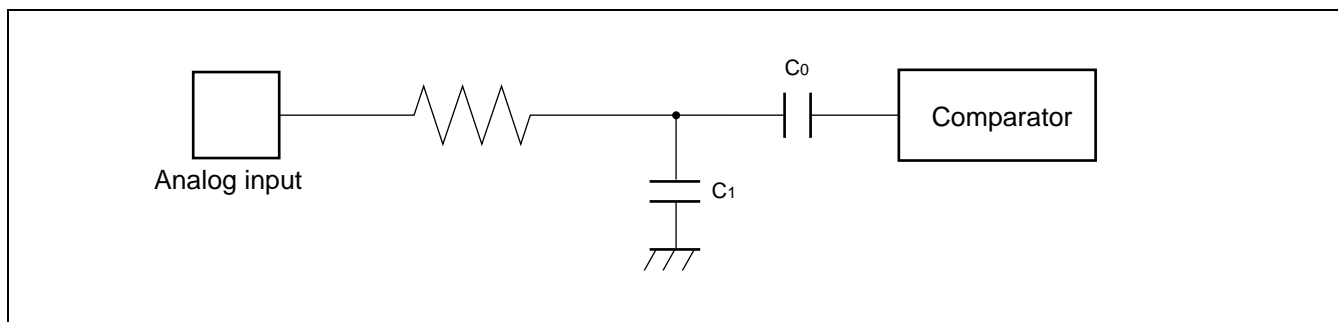

6. A/D Converter Glossary

Resolution : Analog changes that are identifiable with the A/D converter

Linearity error : The deviation of the straight line connecting the zero transition point (“00 0000 0000” ↔ “00 0000 0001”) with the full-scale transition point (“11 1111 1110” ↔ “11 1111 1111”) from actual conversion characteristics

Differential linearity error : The deviation of input voltage needed to change the output code by 1 LSB from the theoretical value

Total error : The total error is defined as a difference between the actual value and the theoretical value, which includes zero-transition error/full-scale transition error and linearity error.

www.DataSheet4U.com

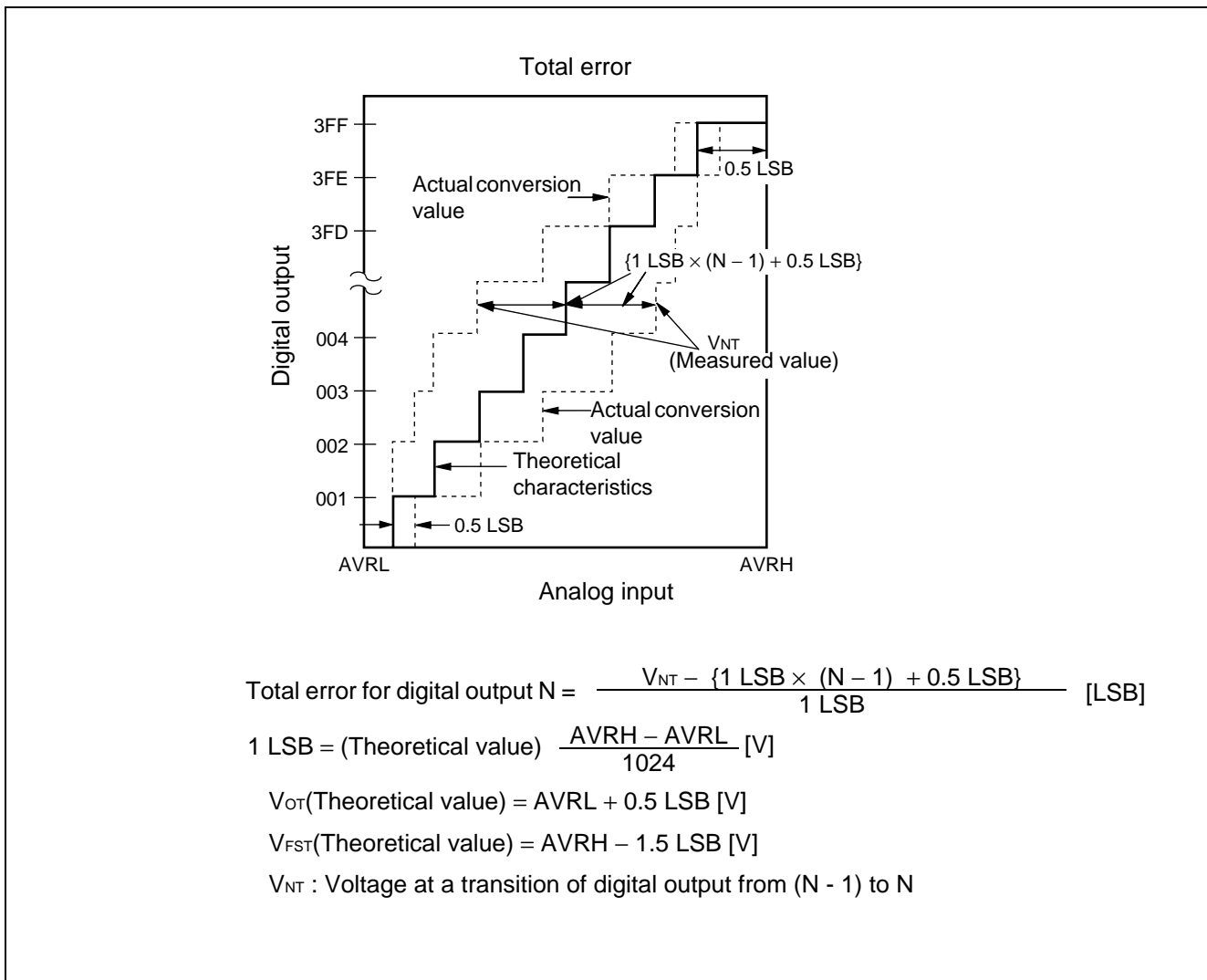

(Continued)

(Continued)

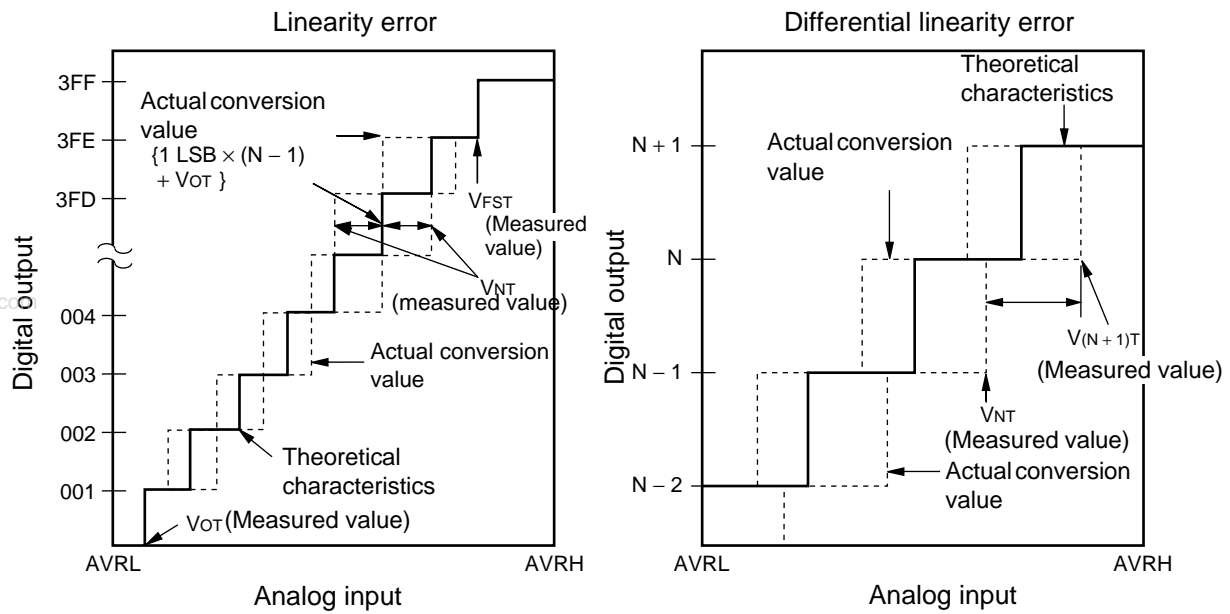

$$\text{Linearity error of digital output } N = \frac{V_{NT} - \{1 \text{ LSB} \times (N - 1) + V_{OT}\}}{1 \text{ LSB}} \quad [\text{LSB}]$$

$$\text{Differential linearity error of digital output } N = \frac{V_{(N+1)T} - V_{NT}}{1 \text{ LSB}} - 1 \text{ LSB} [\text{LSB}]$$

$$1 \text{ LSB} = \frac{V_{FST} - V_{OT}}{1022} \quad [\text{V}]$$

V_{OT} : Voltage at transition of digital output from "000_H" to "001_H"
 V_{FST} : Voltage at transition of digital output from "3FE_H" to "3FF_H"

MB90580B Series

7. Notes on Using A/D Converter

Select the output impedance value for the external circuit of analog input according to the following conditions.

Output impedance values of the external circuit of 7 kΩ or lower are recommended.

When capacitors are connected to external pins, the capacitance of several thousand times the internal capacitor value is recommended to minimized the effect of voltage distribution between the external capacitor and internal capacitor.

When the output impedance of the external circuit is too high, the sampling period for analog voltages may not be sufficient (sampling period = 4.00 μs @ machine clock of 16 MHz)

www.DataSheet4U.com

• Equipment of analog input circuit model

MB90587, MB90V580B	$R \cong 1.5 \text{ k}\Omega$, $C \cong 30 \text{ pF}$
MB90F583B	$R \cong 3.0 \text{ k}\Omega$, $C \cong 65 \text{ pF}$
MB90583B	$R \cong 2.2 \text{ k}\Omega$, $C \cong 45 \text{ pF}$

Note: Listed values must be considered as standards.

• Error

The smaller the $|AVRH - AVRL|$, the greater the error would become relatively.

8. D/A Converter Electrical Characteristics

($V_{CC} = AV_{CC} = 5.0 \text{ V} \pm 10\%$, $V_{SS} = AV_{SS} = DV_{SS} = 0.0 \text{ V}$, $T_A = -40 \text{ }^\circ\text{C}$ to $+85 \text{ }^\circ\text{C}$)

Parameter	Symbol	Pin name	Value			Unit	Remarks
			Min.	Typ.	Max.		
Resolution	—	—	—	8	—	bit	
Differential linearity error	—	—	—	—	± 0.9	LSB	
Absolute accuracy	—	—	—	—	± 1.2	%	
Linearity error	—	—	—	—	± 1.5	LSB	
Conversion time	—	—	—	10	20	μs	*1
Analog reference voltage	—	DVRH	$V_{SS} + 3.0$	—	AV_{CC}	V	
Reference voltage supply current	I_{DVR}	DVRH	—	120	300	μA	
	I_{DVRS}		—	—	10	μA	*2
Analog output impedance	—	—	—	20	—	kΩ	

*1 : Load capacitance: 20 pF

*2 : In sleep mode

EXAMPLE CHARACTERISTICS

- Power Supply Current of MB90F583B

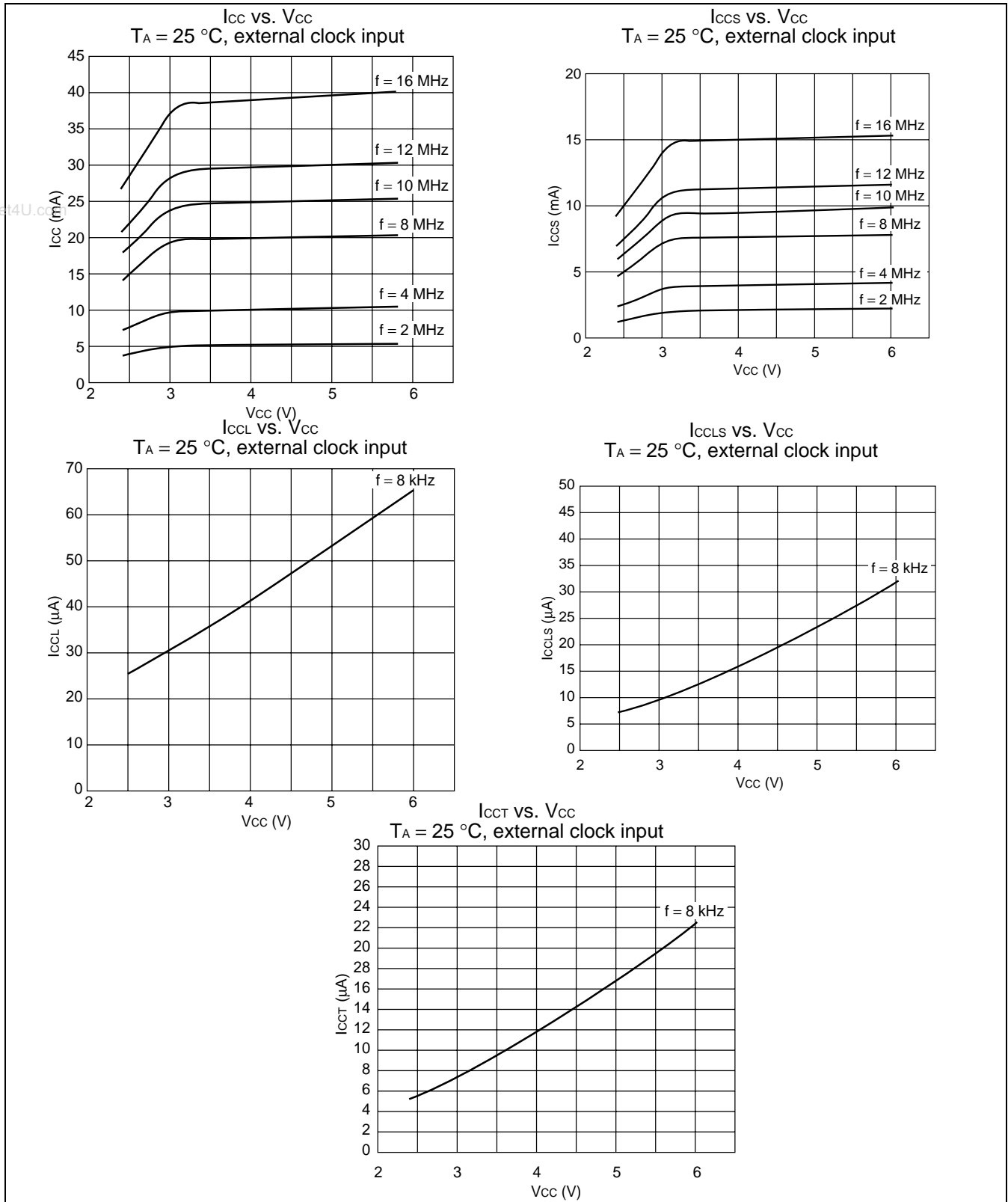

(Continued)

MB90580B Series

(Continued)

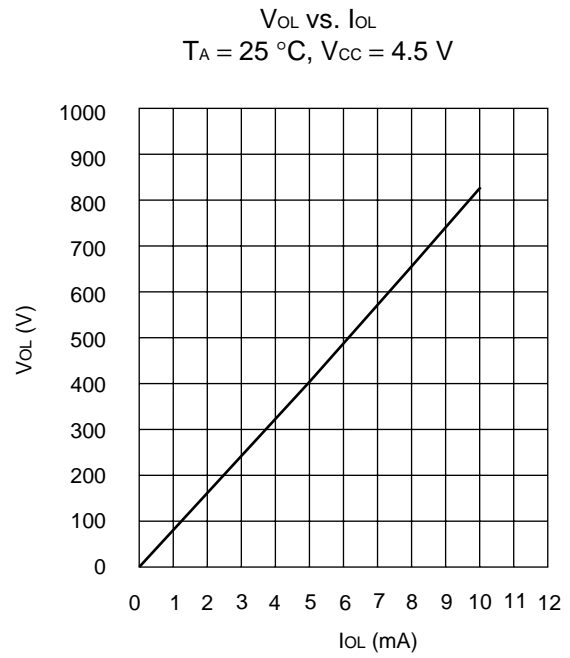
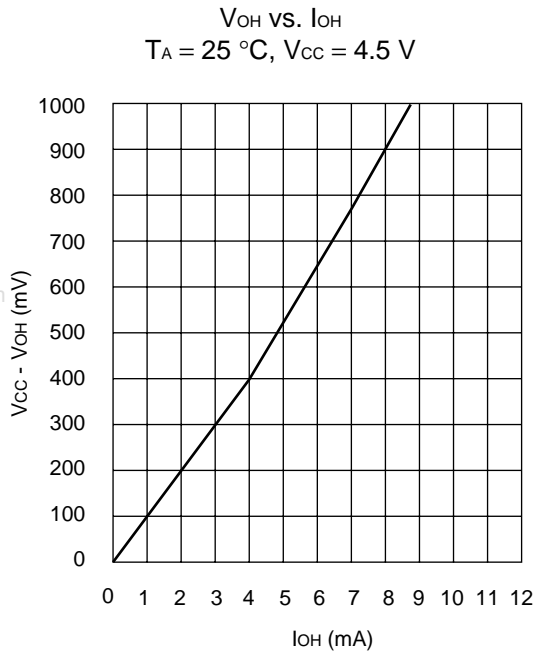

MB90580B Series

Power Supply Current of MB90583B

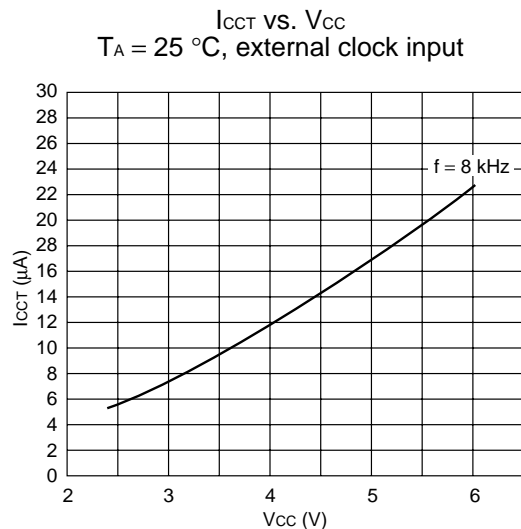
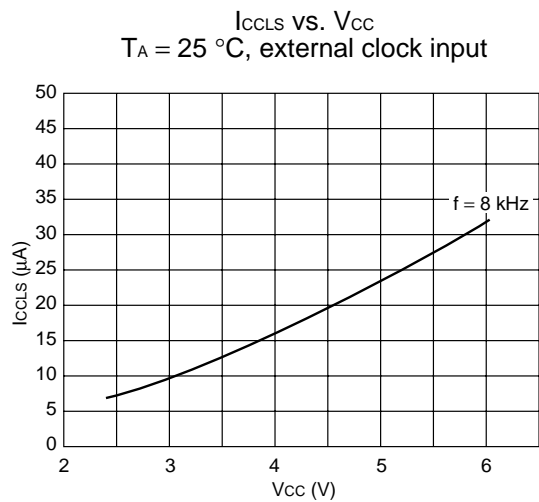
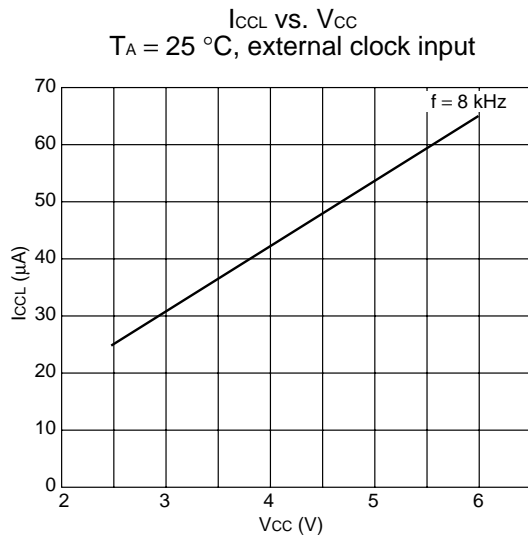
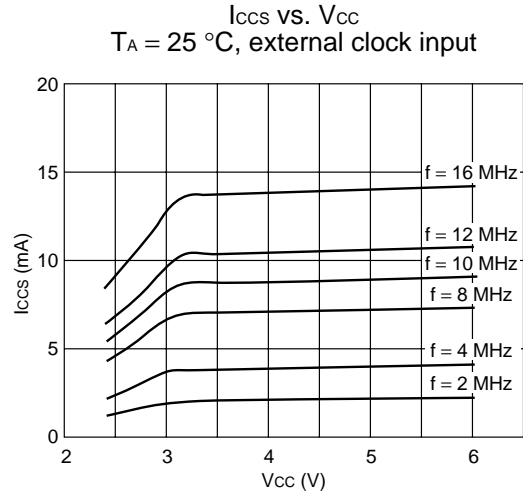
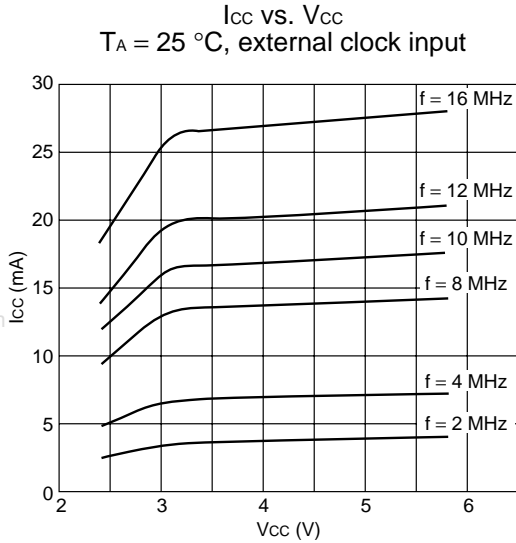

(Continued)

MB90580B Series

(Continued)

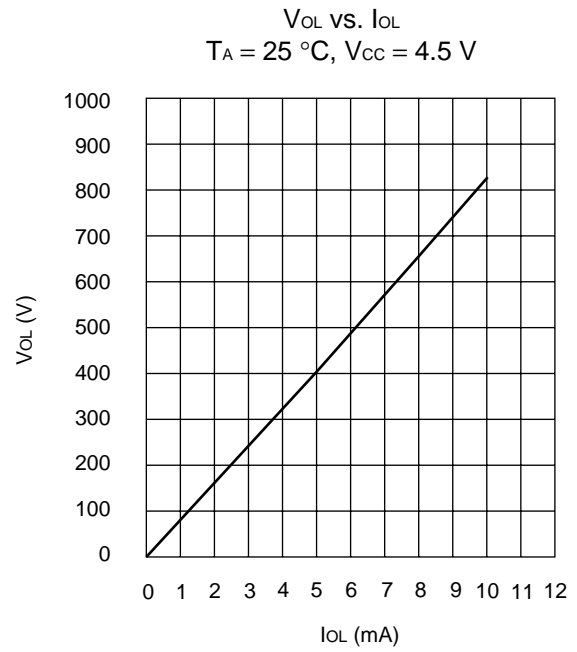
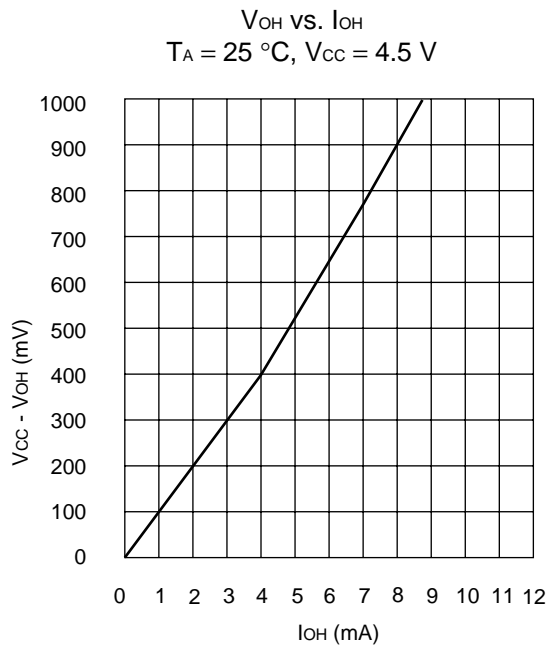

■ INSTRUCTIONS (351 INSTRUCTIONS)

Table 1 Explanation of Items in Tables of Instructions

Item	Meaning
Mnemonic	Upper-case letters and symbols: Represented as they appear in assembler. Lower-case letters: Replaced when described in assembler. Numbers after lower-case letters: Indicate the bit width within the instruction code.
#	Indicates the number of bytes.
~	Indicates the number of cycles. m: When branching n: When not branching See Table 4 for details about meanings of other letters in items.
RG	Indicates the number of accesses to the register during execution of the instruction. It is used calculate a correction value for intermittent operation of CPU.
B	Indicates the correction value for calculating the number of actual cycles during execution of the instruction. (Table 5) The number of actual cycles during execution of the instruction is the correction value summed with the value in the “~” column.
Operation	Indicates the operation of instruction.
LH	Indicates special operations involving the upper 8 bits of the lower 16 bits of the accumulator. Z: Transfers “0”. X: Extends with a sign before transferring. –: Transfers nothing.
AH	Indicates special operations involving the upper 16 bits in the accumulator. *: Transfers from AL to AH. –: No transfer. Z: Transfers 00 _H to AH. X: Transfers 00 _H or FF _H to AH by signing and extending AL.
I	Indicates the status of each of the following flags: I (interrupt enable), S (stack), T (sticky bit), N (negative), Z (zero), V (overflow), and C (carry). *: Changes due to execution of instruction. –: No change. S: Set by execution of instruction. R: Reset by execution of instruction.
S	
T	
N	
Z	
C	
RMW	Indicates whether the instruction is a read-modify-write instruction. (a single instruction that reads data from memory, etc., processes the data, and then writes the result to memory.) *: Instruction is a read-modify-write instruction. –: Instruction is not a read-modify-write instruction. Note: A read-modify-write instruction cannot be used on addresses that have different meanings depending on whether they are read or written.

• Number of execution cycles

The number of cycles required for instruction execution is acquired by adding the number of cycles for each instruction, a corrective value depending on the condition, and the number of cycles required for program fetch. Whenever the instruction being executed exceeds the two-byte (word) boundary, a program on an internal ROM connected to a 16-bit bus is fetched. If data access is interfered with, therefore, the number of execution cycles is increased.

For each byte of the instruction being executed, a program on a memory connected to an 8-bit external data bus is fetched. If data access is interfered with, therefore, the number of execution cycles is increased.

When a general-purpose register, an internal ROM, an internal RAM, an internal I/O device, or an external bus is accessed during intermittent CPU operation, the CPU clock is suspended by the number of cycles specified by the CG1/0 bit of the low-power consumption mode control register. When determining the number of cycles required for instruction execution during intermittent CPU operation, therefore, add the value of the number of times access is done × the number of cycles suspended as the corrective value to the number of ordinary execution cycles.

MB90580B Series

Table 2 Explanation of Symbols in Tables of Instructions

Symbol	Meaning
A	32-bit accumulator The bit length varies according to the instruction. Byte : Lower 8 bits of AL Word : 16 bits of AL Long : 32 bits of AL and AH
AH AL	Upper 16 bits of A Lower 16 bits of A
SP	Stack pointer (USP or SSP)
PC	Program counter
PCB	Program bank register
DTB	Data bank register
ADB	Additional data bank register
SSB	System stack bank register
USB	User stack bank register
SPB	Current stack bank register (SSB or USB)
DPR	Direct page register
brg1	DTB, ADB, SSB, USB, DPR, PCB, SPB
brg2	DTB, ADB, SSB, USB, DPR, SPB
Ri	R0, R1, R2, R3, R4, R5, R6, R7
RWi	RW0, RW1, RW2, RW3, RW4, RW5, RW6, RW7
RWj	RW0, RW1, RW2, RW3
RLi	RL0, RL1, RL2, RL3
dir	Compact direct addressing
addr16 addr24 ad24 0 to 15 ad24 16 to 23	Direct addressing Physical direct addressing Bit 0 to bit 15 of addr24 Bit 16 to bit 23 of addr24
io	I/O area (000000 _H to 0000FF _H)
imm4 imm8 imm16 imm32 ext (imm8)	4-bit immediate data 8-bit immediate data 16-bit immediate data 32-bit immediate data 16-bit data signed and extended from 8-bit immediate data
disp8 disp16	8-bit displacement 16-bit displacement
bp	Bit offset
vct4 vct8	Vector number (0 to 15) Vector number (0 to 255)
()b	Bit address
rel	PC relative addressing
ear eam	Effective addressing (codes 00 to 07) Effective addressing (codes 08 to 1F)
rlst	Register list

Table 3 Effective Address Fields

Code	Notation			Address format	Number of bytes in address extension *
00	R0	RW0	RL0	Register direct	—
01	R1	RW1	(RL0)	“ea” corresponds to byte, word, and long-word types, starting from the left	
02	R2	RW2	RL1		
03	R3	RW3	(RL1)		
04	R4	RW4	RL2		
05	R5	RW5	(RL2)		
06	R6	RW6	RL3		
07	R7	RW7	(RL3)		
08	@RW0				Register indirect
09	@RW1				
0A	@RW2				
0B	@RW3				
0C	@RW0 +			Register indirect with post-increment	0
0D	@RW1 +				
0E	@RW2 +				
0F	@RW3 +				
10	@RW0 + disp8			Register indirect with 8-bit displacement	1
11	@RW1 + disp8				
12	@RW2 + disp8				
13	@RW3 + disp8				
14	@RW4 + disp8				
15	@RW5 + disp8				
16	@RW6 + disp8				
17	@RW7 + disp8				
18	@RW0 + disp16			Register indirect with 16-bit displacement	2
19	@RW1 + disp16				
1A	@RW2 + disp16				
1B	@RW3 + disp16				
1C	@RW0 + RW7			Register indirect with index	0
1D	@RW1 + RW7			Register indirect with index	0
1E	@PC + disp16			PC indirect with 16-bit displacement	2
1F	addr16			Direct address	2

Note : The number of bytes in the address extension is indicated by the “+” symbol in the “#” (number of bytes) column in the tables of instructions.

MB90580B Series

Table 4 Number of Execution Cycles for Each Type of Addressing

Code	Operand	(a)	Number of register accesses for each type of addressing
		Number of execution cycles for each type of addressing	
00 to 07	Ri RWi RLi	Listed in tables of instructions	Listed in tables of instructions
08 to 0B	@RWj	2	1
0C to 0F	@RWj +	4	2
10 to 17	@RWi + disp8	2	1
18 to 1B	@RWj + disp16	2	1
1C	@RW0 + RW7	4	2
1D	@RW1 + RW7	4	2
1E	@PC + disp16	2	0
1F	addr16	1	0

Note : “(a)” is used in the “~” (number of states) column and column B (correction value) in the tables of instructions.

Table 5 Compensation Values for Number of Cycles Used to Calculate Number of Actual Cycles

Operand	(b) byte		(c) word		(d) long	
	Cycles	Access	Cycles	Access	Cycles	Access
Internal register	+0	1	+0	1	+0	2
Internal memory even address	+0	1	+0	1	+0	2
Internal memory odd address	+0	1	+2	2	+4	4
Even address on external data bus (16 bits)	+1	1	+1	1	+2	2
Odd address on external data bus (16 bits)	+1	1	+4	2	+8	4
External data bus (8 bits)	+1	1	+4	2	+8	4

Notes: • “(b)”, “(c)”, and “(d)” are used in the “~” (number of states) column and column B (correction value) in the tables of instructions.

- When the external data bus is used, it is necessary to add in the number of wait cycles used for ready input and automatic ready.

Table 6 Correction Values for Number of Cycles Used to Calculate Number of Program Fetch Cycles

Instruction	Byte boundary	Word boundary
Internal memory	—	+2
External data bus (16 bits)	—	+3
External data bus (8 bits)	+3	—

Notes: • When the external data bus is used, it is necessary to add in the number of wait cycles used for ready input and automatic ready.

- Because instruction execution is not slowed down by all program fetches in actuality, these correction values should be used for “worst case” calculations.

Table 7 Transfer Instructions (Byte) [41 Instructions]

Mnemonic	#	~	RG	B	Operation	LH	AH	I	S	T	N	Z	V	C	RMW
MOV A, dir	2	3	0	(b)	byte (A) ← (dir)	Z	*	-	-	-	*	*	-	-	-
MOV A, addr16	3	4	0	(b)	byte (A) ← (addr16)	Z	*	-	-	-	*	*	-	-	-
MOV A, Ri	1	2	1	0	byte (A) ← (Ri)	Z	*	-	-	-	*	*	-	-	-
MOV A, ear	2	2	1	0	byte (A) ← (ear)	Z	*	-	-	-	*	*	-	-	-
MOV A, eam	2+	3+ (a)	0	(b)	byte (A) ← (eam)	Z	*	-	-	-	*	*	-	-	-
MOV A, io	2	3	0	(b)	byte (A) ← (io)	Z	*	-	-	-	*	*	-	-	-
MOV A, #imm8	2	2	0	0	byte (A) ← imm8	Z	*	-	-	-	*	*	-	-	-
MOV A, @A	2	3	0	(b)	byte (A) ← ((A))	Z	-	-	-	-	*	*	-	-	-
MOV A, @RLi+disp8	3	10	2	(b)	byte (A) ← ((RLi)+disp8)	Z	*	-	-	-	*	*	-	-	-
MOVN A, #imm4	1	1	0	0	byte (A) ← imm4	Z	*	-	-	-	R	*	-	-	-
MOVX A, dir	2	3	0	(b)	byte (A) ← (dir)	X	*	-	-	-	*	*	-	-	-
MOVX A, addr16	3	4	0	(b)	byte (A) ← (addr16)	X	*	-	-	-	*	*	-	-	-
MOVX A, Ri	2	2	1	0	byte (A) ← (Ri)	X	*	-	-	-	*	*	-	-	-
MOVX A, ear	2	2	1	0	byte (A) ← (ear)	X	*	-	-	-	*	*	-	-	-
MOVX A, eam	2+	3+ (a)	0	(b)	byte (A) ← (eam)	X	*	-	-	-	*	*	-	-	-
MOVX A, io	2	3	0	(b)	byte (A) ← (io)	X	*	-	-	-	*	*	-	-	-
MOVX A, #imm8	2	2	0	0	byte (A) ← imm8	X	*	-	-	-	*	*	-	-	-
MOVX A, @A	2	3	0	(b)	byte (A) ← ((A))	X	-	-	-	-	*	*	-	-	-
MOVX A, @RWi+disp8	2	5	1	(b)	byte (A) ← ((RWi)+disp8)	X	*	-	-	-	*	*	-	-	-
MOVX A, @RLi+disp8	3	10	2	(b)	byte (A) ← ((RLi)+disp8)	X	*	-	-	-	*	*	-	-	-
MOV dir, A	2	3	0	(b)	byte (dir) ← (A)	-	-	-	-	-	*	*	-	-	-
MOV addr16, A	3	4	0	(b)	byte (addr16) ← (A)	-	-	-	-	-	*	*	-	-	-
MOV Ri, A	1	2	1	0	byte (Ri) ← (A)	-	-	-	-	-	*	*	-	-	-
MOV ear, A	2	2	1	0	byte (ear) ← (A)	-	-	-	-	-	*	*	-	-	-
MOV eam, A	2+	3+ (a)	0	(b)	byte (eam) ← (A)	-	-	-	-	-	*	*	-	-	-
MOV io, A	2	3	0	(b)	byte (io) ← (A)	-	-	-	-	-	*	*	-	-	-
MOV @RLi+disp8, A	3	10	2	(b)	byte ((RLi) +disp8) ← (A)	-	-	-	-	-	*	*	-	-	-
MOV Ri, ear	2	3	2	0	byte (Ri) ← (ear)	-	-	-	-	-	*	*	-	-	-
MOV Ri, eam	2+	4+ (a)	1	(b)	byte (Ri) ← (eam)	-	-	-	-	-	*	*	-	-	-
MOV ear, Ri	2	4	2	0	byte (ear) ← (Ri)	-	-	-	-	-	*	*	-	-	-
MOV eam, Ri	2+	5+ (a)	1	(b)	byte (eam) ← (Ri)	-	-	-	-	-	*	*	-	-	-
MOV Ri, #imm8	2	2	1	0	byte (Ri) ← imm8	-	-	-	-	-	*	*	-	-	-
MOV io, #imm8	3	5	0	(b)	byte (io) ← imm8	-	-	-	-	-	-	-	-	-	-
MOV dir, #imm8	3	5	0	(b)	byte (dir) ← imm8	-	-	-	-	-	-	-	-	-	-
MOV ear, #imm8	3	2	1	0	byte (ear) ← imm8	-	-	-	-	-	*	*	-	-	-
MOV eam, #imm8	3+	4+ (a)	0	(b)	byte (eam) ← imm8	-	-	-	-	-	-	-	-	-	-
MOV @AL, AH											*	*			
/MOV @A, T	2	3	0	(b)	byte ((A)) ← (AH)	-	-	-	-	-	*	*	-	-	-
XCH A, ear	2	4	2	0	byte (A) ↔ (ear)	Z	-	-	-	-	-	-	-	-	-
XCH A, eam	2+	5+ (a)	0	2× (b)	byte (A) ↔ (eam)	Z	-	-	-	-	-	-	-	-	-
XCH Ri, ear	2	7	4	0	byte (Ri) ↔ (ear)	-	-	-	-	-	-	-	-	-	-
XCH Ri, eam	2+	9+ (a)	2	2× (b)	byte (Ri) ↔ (eam)	-	-	-	-	-	-	-	-	-	-

Note : For an explanation of “(a)” to “(d)”, refer to Table 4, “Number of Execution Cycles for Each Type of Addressing,” and Table 5, “Correction Values for Number of Cycles Used to Calculate Number of Actual Cycles.”

MB90580B Series

Table 8 Transfer Instructions (Word/Long Word) [38 Instructions]

Mnemonic	#	~	RG	B	Operation	LH	AH	I	S	T	N	Z	V	C	RMW
MOVW A, dir	2	3	0	(c)	word (A) ← (dir)	-	*	-	-	-	*	*	-	-	-
MOVW A, addr16	3	4	0	(c)	word (A) ← (addr16)	-	*	-	-	-	*	*	-	-	-
MOVW A, SP	1	1	0	0	word (A) ← (SP)	-	*	-	-	-	*	*	-	-	-
MOVW A, RWi	1	2	1	0	word (A) ← (RWi)	-	*	-	-	-	*	*	-	-	-
MOVW A, ear	2	2	1	0	word (A) ← (ear)	-	*	-	-	-	*	*	-	-	-
MOVW A, eam	2+	3+ (a)	0	(c)	word (A) ← (eam)	-	*	-	-	-	*	*	-	-	-
MOVW A, io	2	3	0	(c)	word (A) ← (io)	-	*	-	-	-	*	*	-	-	-
MOVW A, @A	2	3	0	(c)	word (A) ← ((A))	-	-	-	-	-	*	*	-	-	-
MOVW A, #imm16	3	2	0	0	word (A) ← imm16	-	*	-	-	-	*	*	-	-	-
MOVW A, @RWi+disp8	2	5	1	(c)	word (A) ← ((RWi) +disp8)	-	*	-	-	-	*	*	-	-	-
MOVW A, @RLi+disp8	3	10	2	(c)	word (A) ← ((RLi) +disp8)	-	*	-	-	-	*	*	-	-	-
MOVW dir, A	2	3	0	(c)	word (dir) ← (A)	-	-	-	-	-	*	*	-	-	-
MOVW addr16, A	3	4	0	(c)	word (addr16) ← (A)	-	-	-	-	-	*	*	-	-	-
MOVW SP, A	1	1	0	0	word (SP) ← (A)	-	-	-	-	-	*	*	-	-	-
MOVW RWi, A	1	2	1	0	word (RWi) ← (A)	-	-	-	-	-	*	*	-	-	-
MOVW ear, A	2	2	1	0	word (ear) ← (A)	-	-	-	-	-	*	*	-	-	-
MOVW eam, A	2+	3+ (a)	0	(c)	word (eam) ← (A)	-	-	-	-	-	*	*	-	-	-
MOVW io, A	2	3	0	(c)	word (io) ← (A)	-	-	-	-	-	*	*	-	-	-
MOVW @RWi+disp8, A	2	5	1	(c)	word ((RWi) +disp8) ← (A)	-	-	-	-	-	*	*	-	-	-
MOVW @RLi+disp8, A	3	10	2	(c)	word ((RLi) +disp8) ← (A)	-	-	-	-	-	*	*	-	-	-
MOVW RWi, ear	2	3	2	(0)	word (RWi) ← (ear)	-	-	-	-	-	*	*	-	-	-
MOVW RWi, eam	2+	4+ (a)	1	(c)	word (RWi) ← (eam)	-	-	-	-	-	*	*	-	-	-
MOVW ear, RWi	2	4	2	0	word (ear) ← (RWi)	-	-	-	-	-	*	*	-	-	-
MOVW eam, RWi	2+	5+ (a)	1	(c)	word (eam) ← (RWi)	-	-	-	-	-	*	*	-	-	-
MOVW RWi, #imm16	3	2	1	0	word (RWi) ← imm16	-	-	-	-	-	*	*	-	-	-
MOVW io, #imm16	4	5	0	(c)	word (io) ← imm16	-	-	-	-	-	*	*	-	-	-
MOVW ear, #imm16	4	2	1	0	word (ear) ← imm16	-	-	-	-	-	*	*	-	-	-
MOVW eam, #imm16	4+	4+ (a)	0	(c)	word (eam) ← imm16	-	-	-	-	-	*	*	-	-	-
MOVW @AL, AH /MOVW @A, T	2	3	0	(c)	word ((A)) ← (AH)	-	-	-	-	-	*	*	-	-	-
XCHW A, ear	2	4	2	0	word (A) ↔ (ear)	-	-	-	-	-	-	-	-	-	-
XCHW A, eam	2+	5+ (a)	0	2× (c)	word (A) ↔ (eam)	-	-	-	-	-	-	-	-	-	-
XCHW RWi, ear	2	7	4	0	word (RWi) ↔ (ear)	-	-	-	-	-	-	-	-	-	-
XCHW RWi, eam	2+	9+ (a)	2	2× (c)	word (RWi) ↔ (eam)	-	-	-	-	-	-	-	-	-	-
MOVL A, ear	2	4	2	0	long (A) ← (ear)	-	-	-	-	-	*	*	-	-	-
MOVL A, eam	2+	5+ (a)	0	(d)	long (A) ← (eam)	-	-	-	-	-	*	*	-	-	-
MOVL A, #imm32	5	3	0	0	long (A) ← imm32	-	-	-	-	-	*	*	-	-	-
MOVL ear, A	2	4	2	0	long (ear) ← (A)	-	-	-	-	-	*	*	-	-	-
MOVL eam, A	2+	5+ (a)	0	(d)	long (eam) ← (A)	-	-	-	-	-	*	*	-	-	-

Note : For an explanation of “(a)” to “(d)”, refer to Table 4, “Number of Execution Cycles for Each Type of Addressing,” and Table 5, “Correction Values for Number of Cycles Used to Calculate Number of Actual Cycles.”

Table 9 Addition and Subtraction Instructions (Byte/Word/Long Word) [42 Instructions]

Mnemonic	#	~	RG	B	Operation	LH	AH	I	S	T	N	Z	V	C	RMW
ADD A, #imm8	2	2	0	0	byte (A) ← (A) +imm8	Z	-	-	-	-	*	*	*	*	-
ADD A, dir	2	5	0	(b)	byte (A) ← (A) +(dir)	Z	-	-	-	-	*	*	*	*	-
ADD A, ear	2	3	1	0	byte (A) ← (A) +(ear)	Z	-	-	-	-	*	*	*	*	-
ADD A, eam	2+	4+ (a)	0	(b)	byte (A) ← (A) +(eam)	Z	-	-	-	-	*	*	*	*	-
ADD ear, A	2	3	2	0	byte (ear) ← (ear) + (A)	-	-	-	-	-	*	*	*	*	-
ADD eam, A	2+	5+ (a)	0	2× (b)	byte (eam) ← (eam) + (A)	Z	-	-	-	-	*	*	*	*	*
ADDC A	1	2	0	0	byte (A) ← (AH) + (AL) + (C)	Z	-	-	-	-	*	*	*	*	-
ADDC A, ear	2	3	1	0	byte (A) ← (A) + (ear) + (C)	Z	-	-	-	-	*	*	*	*	-
ADDC A, eam	2+	4+ (a)	0	(b)	byte (A) ← (A) + (eam) + (C)	Z	-	-	-	-	*	*	*	*	-
ADDC A	1	3	0	0	byte (A) ← (AH) + (AL) + (C) (decimal)	Z	-	-	-	-	*	*	*	*	-
SUB A, #imm8	2	2	0	0	byte (A) ← (A) -imm8	Z	-	-	-	-	*	*	*	*	-
SUB A, dir	2	5	0	(b)	byte (A) ← (A) - (dir)	Z	-	-	-	-	*	*	*	*	-
SUB A, ear	2	3	1	0	byte (A) ← (A) - (ear)	Z	-	-	-	-	*	*	*	*	-
SUB A, eam	2+	4+ (a)	0	(b)	byte (A) ← (A) - (eam)	Z	-	-	-	-	*	*	*	*	-
SUB ear, A	2	3	2	0	byte (ear) ← (ear) - (A)	-	-	-	-	-	*	*	*	*	-
SUB eam, A	2+	5+ (a)	0	2× (b)	byte (eam) ← (eam) - (A)	-	-	-	-	-	*	*	*	*	*
SUBC A	1	2	0	0	byte (A) ← (AH) - (AL) - (C)	Z	-	-	-	-	*	*	*	*	-
SUBC A, ear	2	3	1	0	byte (A) ← (A) - (ear) - (C)	Z	-	-	-	-	*	*	*	*	-
SUBC A, eam	2+	4+ (a)	0	(b)	byte (A) ← (A) - (eam) - (C)	Z	-	-	-	-	*	*	*	*	-
SUBDC A	1	3	0	0	byte (A) ← (AH) - (AL) - (C) (decimal)	Z	-	-	-	-	*	*	*	*	-
ADDW A	1	2	0	0	word (A) ← (AH) + (AL)	-	-	-	-	-	*	*	*	*	-
ADDW A, ear	2	3	1	0	word (A) ← (A) +(ear)	-	-	-	-	-	*	*	*	*	-
ADDW A, eam	2+	4+ (a)	0	(c)	word (A) ← (A) +(eam)	-	-	-	-	-	*	*	*	*	-
ADDW A, #imm16	3	2	0	0	word (A) ← (A) +imm16	-	-	-	-	-	*	*	*	*	-
ADDW ear, A	2	3	2	0	word (ear) ← (ear) + (A)	-	-	-	-	-	*	*	*	*	-
ADDW eam, A	2+	5+ (a)	0	2× (c)	word (eam) ← (eam) + (A)	-	-	-	-	-	*	*	*	*	*
ADDCW A, ear	2	3	1	0	word (A) ← (A) + (ear) + (C)	-	-	-	-	-	*	*	*	*	-
ADDCW A, eam	2+	4+ (a)	0	(c)	word (A) ← (A) + (eam) + (C)	-	-	-	-	-	*	*	*	*	-
SUBW A	1	2	0	0	word (A) ← (AH) - (AL)	-	-	-	-	-	*	*	*	*	-
SUBW A, ear	2	3	1	0	word (A) ← (A) - (ear)	-	-	-	-	-	*	*	*	*	-
SUBW A, eam	2+	4+ (a)	0	(c)	word (A) ← (A) - (eam)	-	-	-	-	-	*	*	*	*	-
SUBW A, #imm16	3	2	0	0	word (A) ← (A) -imm16	-	-	-	-	-	*	*	*	*	-
SUBW ear, A	2	3	2	0	word (ear) ← (ear) - (A)	-	-	-	-	-	*	*	*	*	-
SUBW eam, A	2+	5+ (a)	0	2× (c)	word (eam) ← (eam) - (A)	-	-	-	-	-	*	*	*	*	*
SUBCW A, ear	2	3	1	0	word (A) ← (A) - (ear) - (C)	-	-	-	-	-	*	*	*	*	-
SUBCW A, eam	2+	4+ (a)	0	(c)	word (A) ← (A) - (eam) - (C)	-	-	-	-	-	*	*	*	*	-
ADDL A, ear	2	6	2	0	long (A) ← (A) + (ear)	-	-	-	-	-	*	*	*	*	-
ADDL A, eam	2+	7+ (a)	0	(d)	long (A) ← (A) + (eam)	-	-	-	-	-	*	*	*	*	-
ADDL A, #imm32	5	4	0	0	long (A) ← (A) +imm32	-	-	-	-	-	*	*	*	*	-
SUBL A, ear	2	6	2	0	long (A) ← (A) - (ear)	-	-	-	-	-	*	*	*	*	-
SUBL A, eam	2+	7+ (a)	0	(d)	long (A) ← (A) - (eam)	-	-	-	-	-	*	*	*	*	-
SUBL A, #imm32	5	4	0	0	long (A) ← (A) -imm32	-	-	-	-	-	*	*	*	*	-

Note : For an explanation of “(a)” to “(d)”, refer to Table 4, “Number of Execution Cycles for Each Type of Addressing,” and Table 5, “Correction Values for Number of Cycles Used to Calculate Number of Actual Cycles.”

MB90580B Series

Table 10 Increment and Decrement Instructions (Byte/Word/Long Word) [12 Instructions]

Mnemonic	#	~	RG	B	Operation	LH	AH	I	S	T	N	Z	V	C	RMW
INC ear	2	2	2	0	byte (ear) ← (ear) +1	–	–	–	–	–	*	*	*	–	–
INC eam	2+	5+ (a)	0	2× (b)	byte (eam) ← (eam) +1	–	–	–	–	–	*	*	*	–	*
DEC ear	2	3	2	0	byte (ear) ← (ear) –1	–	–	–	–	–	*	*	*	–	–
DEC eam	2+	5+ (a)	0	2× (b)	byte (eam) ← (eam) –1	–	–	–	–	–	*	*	*	–	*
INCW ear	2	3	2	0	word (ear) ← (ear) +1	–	–	–	–	–	*	*	*	–	–
INCW eam	2+	5+ (a)	0	2× (c)	word (eam) ← (eam) +1	–	–	–	–	–	*	*	*	–	*
DECW ear	2	3	2	0	word (ear) ← (ear) –1	–	–	–	–	–	*	*	*	–	–
DECW eam	2+	5+ (a)	0	2× (c)	word (eam) ← (eam) –1	–	–	–	–	–	*	*	*	–	*
INCL ear	2	7	4	0	long (ear) ← (ear) +1	–	–	–	–	–	*	*	*	–	–
INCL eam	2+	9+ (a)	0	2× (d)	long (eam) ← (eam) +1	–	–	–	–	–	*	*	*	–	*
DECL ear	2	7	4	0	long (ear) ← (ear) –1	–	–	–	–	–	*	*	*	–	–
DECL eam	2+	9+ (a)	0	2× (d)	long (eam) ← (eam) –1	–	–	–	–	–	*	*	*	–	*

Note : For an explanation of “(a)” to “(d)”, refer to Table 4, “Number of Execution Cycles for Each Type of Addressing,” and Table 5, “Correction Values for Number of Cycles Used to Calculate Number of Actual Cycles.”

Table 11 Compare Instructions (Byte/Word/Long Word) [11 Instructions]

Mnemonic	#	~	RG	B	Operation	LH	AH	I	S	T	N	Z	V	C	RMW
CMP A	1	1	0	0	byte (AH) – (AL)	–	–	–	–	–	*	*	*	*	–
CMP A, ear	2	2	1	0	byte (A) ← (ear)	–	–	–	–	–	*	*	*	*	–
CMP A, eam	2+	3+ (a)	0	(b)	byte (A) ← (eam)	–	–	–	–	–	*	*	*	*	–
CMP A, #imm8	2	2	0	0	byte (A) ← imm8	–	–	–	–	–	*	*	*	*	–
CMPW A	1	1	0	0	word (AH) – (AL)	–	–	–	–	–	*	*	*	*	–
CMPW A, ear	2	2	1	0	word (A) ← (ear)	–	–	–	–	–	*	*	*	*	–
CMPW A, eam	2+	3+ (a)	0	(c)	word (A) ← (eam)	–	–	–	–	–	*	*	*	*	–
CMPW A, #imm16	3	2	0	0	word (A) ← imm16	–	–	–	–	–	*	*	*	*	–
CMPL A, ear	2	6	2	0	word (A) ← (ear)	–	–	–	–	–	*	*	*	*	–
CMPL A, eam	2+	7+ (a)	0	(d)	word (A) ← (eam)	–	–	–	–	–	*	*	*	*	–
CMPL A, #imm32	5	3	0	0	word (A) ← imm32	–	–	–	–	–	*	*	*	*	–

Note : For an explanation of “(a)” to “(d)”, refer to Table 4, “Number of Execution Cycles for Each Type of Addressing,” and Table 5, “Correction Values for Number of Cycles Used to Calculate Number of Actual Cycles.”

Table 12 Multiplication and Division Instructions (Byte/Word/Long Word) [11 Instructions]

Mnemonic	#	~	RG	B	Operation	LH	AH	I	S	T	N	Z	V	C	RMW
DIVU A	1	*1	0	0	word (AH) /byte (AL) Quotient → byte (AL) Remainder → byte (AH)	—	—	—	—	—	—	—	*	*	—
DIVU A, ear	2	*2	1	0	word (A)/byte (ear) Quotient → byte (A) Remainder → byte (ear)	—	—	—	—	—	—	—	*	*	—
DIVU A, eam	2+	*3	0	*6	word (A)/byte (eam) Quotient → byte (A) Remainder → byte (eam)	—	—	—	—	—	—	—	*	*	—
DIVUW A, ear	2	*4	1	0	long (A)/word (ear) Quotient → word (A) Remainder → word (ear)	—	—	—	—	—	—	—	*	*	—
DIVUW A, eam	2+	*5	0	*7	long (A)/word (eam) Quotient → word (A) Remainder → word (eam)	—	—	—	—	—	—	—	*	*	—
MULU A	1	*8	0	0	byte (AH) *byte (AL) → word (A)	—	—	—	—	—	—	—	—	—	—
MULU A, ear	2	*9	1	0	byte (A) *byte (ear) → word (A)	—	—	—	—	—	—	—	—	—	—
MULU A, eam	2+	*10	0	(b)	byte (A) *byte (eam) → word (A)	—	—	—	—	—	—	—	—	—	—
MULUW A	1	*11	0	0	word (AH) *word (AL) → long (A)	—	—	—	—	—	—	—	—	—	—
MULUW A, ear	2	*12	1	0	word (A) *word (ear) → long (A)	—	—	—	—	—	—	—	—	—	—
MULUW A, eam	2+	*13	0	(c)	word (A) *word (eam) → long (A)	—	—	—	—	—	—	—	—	—	—

*1: 3 when the result is zero, 7 when an overflow occurs, and 15 normally.

*2: 4 when the result is zero, 8 when an overflow occurs, and 16 normally.

*3: 6 + (a) when the result is zero, 9 + (a) when an overflow occurs, and 19 + (a) normally.

*4: 4 when the result is zero, 7 when an overflow occurs, and 22 normally.

*5: 6 + (a) when the result is zero, 8 + (a) when an overflow occurs, and 26 + (a) normally.

*6: (b) when the result is zero or when an overflow occurs, and 2 × (b) normally.

*7: (c) when the result is zero or when an overflow occurs, and 2 × (c) normally.

*8: 3 when byte (AH) is zero, and 7 when byte (AH) is not zero.

*9: 4 when byte (ear) is zero, and 8 when byte (ear) is not zero.

*10: 5 + (a) when byte (eam) is zero, and 9 + (a) when byte (eam) is not 0.

*11: 3 when word (AH) is zero, and 11 when word (AH) is not zero.

*12: 4 when word (ear) is zero, and 12 when word (ear) is not zero.

*13: 5 + (a) when word (eam) is zero, and 13 + (a) when word (eam) is not zero.

Note : For an explanation of “(a)” to “(d)”, refer to Table 4, “Number of Execution Cycles for Each Type of Addressing,” and Table 5, “Correction Values for Number of Cycles Used to Calculate Number of Actual Cycles.”

MB90580B Series

Table 13 Signed Multiplication and Division Instructions (Byte/Word/Long Word) [11 Instructions]

Mnemonic	#	~	RG	B	Operation	LH	AH	I	S	T	N	Z	V	C	RMW
DIV A	2	*1	0	0	word (AH) /byte (AL) Quotient → byte (AL) Remainder → byte (AH)	Z	-	-	-	-	-	-	*	*	-
DIV A, ear	2	*2	1	0	word (A)/byte (ear) Quotient → byte (A) Remainder → byte (ear)	Z	-	-	-	-	-	-	*	*	-
DIV A, eam	2 +	*3	0	*6	word (A)/byte (eam) Quotient → byte (A) Remainder → byte (eam)	Z	-	-	-	-	-	-	*	*	-
DIVW A, ear	2	*4	1	0	long (A)/word (ear) Quotient → word (A) Remainder → word (ear)	-	-	-	-	-	-	-	*	*	-
DIVW A, eam	2+	*5	0	*7	long (A)/word (eam) Quotient → word (A) Remainder → word (eam)	-	-	-	-	-	-	-	*	*	-
MULU A	2	*8	0	0	byte (AH) *byte (AL) → word (A)	-	-	-	-	-	-	-	-	-	-
MULU A, ear	2	*9	1	0	byte (A) *byte (ear) → word (A)	-	-	-	-	-	-	-	-	-	-
MULU A, eam	2 +	*10	0	(b)	byte (A) *byte (eam) → word (A)	-	-	-	-	-	-	-	-	-	-
MULUW A	2	*11	0	0	word (AH) *word (AL) → long (A)	-	-	-	-	-	-	-	-	-	-
MULUW A, ear	2	*12	1	0	word (A) *word (ear) → long (A)	-	-	-	-	-	-	-	-	-	-
MULUW A, eam	2 +	*13	0	(c)	word (A) *word (eam) → long (A)	-	-	-	-	-	-	-	-	-	-

- *1: Set to 3 when the division-by-0, 8 or 18 for an overflow, and 18 for normal operation.
- *2: Set to 3 when the division-by-0, 10 or 21 for an overflow, and 22 for normal operation.
- *3: Set to 4 + (a) when the division-by-0, 11 + (a) or 22 + (a) for an overflow, and 23 + (a) for normal operation.
- *4: Positive dividend: Set to 4 when the division-by-0, 10 or 29 for an overflow, and 30 for normal operation.
Negative dividend: Set to 4 when the division-by-0, 11 or 30 for an overflow and 31 for normal operation.
- *5: Positive dividend: Set to 4 + (a) when the division-by-0, 11 + (a) or 30 + (a) for an overflow, and 31 + (a) for normal operation.
Negative dividend: Set to 4 + (a) when the division-by-0, 12 + (a) or 31 + (a) for an overflow, and 32 + (a) for normal operation.
- *6: When the division-by-0, (b) for an overflow, and $2 \times (b)$ for normal operation.
- *7: When the division-by-0, (c) for an overflow, and $2 \times (c)$ for normal operation.
- *8: Set to 3 when byte (AH) is zero, 12 when the result is positive, and 13 when the result is negative.
- *9: Set to 3 when byte (ear) is zero, 12 when the result is positive, and 13 when the result is negative.
- *10: Set to 4 + (a) when byte (eam) is zero, 13 + (a) when the result is positive, and 14 + (a) when the result is negative.
- *11: Set to 3 when word (AH) is zero, 12 when the result is positive, and 13 when the result is negative.
- *12: Set to 3 when word (ear) is zero, 16 when the result is positive, and 19 when the result is negative.
- *13: Set to 4 + (a) when word (eam) is zero, 17 + (a) when the result is positive, and 20 + (a) when the result is negative.

Notes: • When overflow occurs during DIV or DIVW instruction execution, the number of execution cycles takes two values because of detection before and after an operation.
• When overflow occurs during DIV or DIVW instruction execution, the contents of AL are destroyed.
• For (a) to (d), refer to "Table 4 Number of Execution Cycles for Effective Address in Addressing Modes" and "Table 5 Correction Values for Number of Cycles for Calculating Actual Number of Cycles."

Table 14 Logical 1 Instructions (Byte/Word) [39 Instructions]

Mnemonic	#	~	RG	B	Operation	LH	AH	I	S	T	N	Z	V	C	RMW
AND A, #imm8	2	2	0	0	byte (A) ← (A) and imm8	-	-	-	-	-	*	*	R	-	-
AND A, ear	2	3	1	0	byte (A) ← (A) and (ear)	-	-	-	-	-	*	*	R	-	-
AND A, eam	2+	4+ (a)	0	(b)	byte (A) ← (A) and (eam)	-	-	-	-	-	*	*	R	-	-
AND ear, A	2	3	2	0	byte (ear) ← (ear) and (A)	-	-	-	-	-	*	*	R	-	-
AND eam, A	2+	5+ (a)	0	2× (b)	byte (eam) ← (eam) and (A)	-	-	-	-	-	*	*	R	-	*
OR A, #imm8	2	2	0	0	byte (A) ← (A) or imm8	-	-	-	-	-	*	*	R	-	-
OR A, ear	2	3	1	0	byte (A) ← (A) or (ear)	-	-	-	-	-	*	*	R	-	-
OR A, eam	2+	4+ (a)	0	(b)	byte (A) ← (A) or (eam)	-	-	-	-	-	*	*	R	-	-
OR ear, A	2	3	2	0	byte (ear) ← (ear) or (A)	-	-	-	-	-	*	*	R	-	-
OR eam, A	2+	5+ (a)	0	2× (b)	byte (eam) ← (eam) or (A)	-	-	-	-	-	*	*	R	-	*
XOR A, #imm8	2	2	0	0	byte (A) ← (A) xor imm8	-	-	-	-	-	*	*	R	-	-
XOR A, ear	2	3	1	0	byte (A) ← (A) xor (ear)	-	-	-	-	-	*	*	R	-	-
XOR A, eam	2+	4+ (a)	0	(b)	byte (A) ← (A) xor (eam)	-	-	-	-	-	*	*	R	-	-
XOR ear, A	2	3	2	0	byte (ear) ← (ear) xor (A)	-	-	-	-	-	*	*	R	-	-
XOR eam, A	2+	5+ (a)	0	2× (b)	byte (eam) ← (eam) xor (A)	-	-	-	-	-	*	*	R	-	*
NOT A	1	2	0	0	byte (A) ← not (A)	-	-	-	-	-	*	*	R	-	-
NOT ear	2	3	2	0	byte (ear) ← not (ear)	-	-	-	-	-	*	*	R	-	-
NOT eam	2+	5+ (a)	0	2× (b)	byte (eam) ← not (eam)	-	-	-	-	-	*	*	R	-	*
ANDW A	1	2	0	0	word (A) ← (AH) and (A)	-	-	-	-	-	*	*	R	-	-
ANDW A, #imm16	3	2	0	0	word (A) ← (A) and imm16	-	-	-	-	-	*	*	R	-	-
ANDW A, ear	2	3	1	0	word (A) ← (A) and (ear)	-	-	-	-	-	*	*	R	-	-
ANDW A, eam	2+	4+ (a)	0	(c)	word (A) ← (A) and (eam)	-	-	-	-	-	*	*	R	-	-
ANDW ear, A	2	3	2	0	word (ear) ← (ear) and (A)	-	-	-	-	-	*	*	R	-	-
ANDW eam, A	2+	5+ (a)	0	2× (c)	word (eam) ← (eam) and (A)	-	-	-	-	-	*	*	R	-	*
ORW A	1	2	0	0	word (A) ← (AH) or (A)	-	-	-	-	-	*	*	R	-	-
ORW A, #imm16	3	2	0	0	word (A) ← (A) or imm16	-	-	-	-	-	*	*	R	-	-
ORW A, ear	2	3	1	0	word (A) ← (A) or (ear)	-	-	-	-	-	*	*	R	-	-
ORW A, eam	2+	4+ (a)	0	(c)	word (A) ← (A) or (eam)	-	-	-	-	-	*	*	R	-	-
ORW ear, A	2	3	2	0	word (ear) ← (ear) or (A)	-	-	-	-	-	*	*	R	-	-
ORW eam, A	2+	5+ (a)	0	2× (c)	word (eam) ← (eam) or (A)	-	-	-	-	-	*	*	R	-	*
XORW A	1	2	0	0	word (A) ← (AH) xor (A)	-	-	-	-	-	*	*	R	-	-
XORW A, #imm16	3	2	0	0	word (A) ← (A) xor imm16	-	-	-	-	-	*	*	R	-	-
XORW A, ear	2	3	1	0	word (A) ← (A) xor (ear)	-	-	-	-	-	*	*	R	-	-
XORW A, eam	2+	4+ (a)	0	(c)	word (A) ← (A) xor (eam)	-	-	-	-	-	*	*	R	-	-
XORW ear, A	2	3	2	0	word (ear) ← (ear) xor (A)	-	-	-	-	-	*	*	R	-	-
XORW eam, A	2+	5+ (a)	0	2× (c)	word (eam) ← (eam) xor (A)	-	-	-	-	-	*	*	R	-	*
NOTW A	1	2	0	0	word (A) ← not (A)	-	-	-	-	-	*	*	R	-	-
NOTW ear	2	3	2	0	word (ear) ← not (ear)	-	-	-	-	-	*	*	R	-	-
NOTW eam	2+	5+ (a)	0	2× (c)	word (eam) ← not (eam)	-	-	-	-	-	*	*	R	-	*

Note : For an explanation of “(a)” to “(d)”, refer to Table 4, “Number of Execution Cycles for Each Type of Addressing,” and Table 5, “Correction Values for Number of Cycles Used to Calculate Number of Actual Cycles.”

MB90580B Series

Table 15 Logical 2 Instructions (Long Word) [6 Instructions]

Mnemonic	#	~	RG	B	Operation	LH	AH	I	S	T	N	Z	V	C	RMW
ANDL A, ear	2	6	2	0	long (A) ← (A) and (ear)	-	-	-	-	-	*	*	R	-	-
ANDL A, eam	2+	7+ (a)	0	(d)	long (A) ← (A) and (eam)	-	-	-	-	-	*	*	R	-	-
ORL A, ear	2	6	2	0	long (A) ← (A) or (ear)	-	-	-	-	-	*	*	R	-	-
ORL A, eam	2+	7+ (a)	0	(d)	long (A) ← (A) or (eam)	-	-	-	-	-	*	*	R	-	-
XORL A, ea	2	6	2	0	long (A) ← (A) xor (ear)	-	-	-	-	-	*	*	R	-	-
XORL A, eam	2+	7+ (a)	0	(d)	long (A) ← (A) xor (eam)	-	-	-	-	-	*	*	R	-	-

Note : For an explanation of “(a)” to “(d)”, refer to Table 4, “Number of Execution Cycles for Each Type of Addressing,” and Table 5, “Correction Values for Number of Cycles Used to Calculate Number of Actual Cycles.”

Table 16 Sign Inversion Instructions (Byte/Word) [6 Instructions]

Mnemonic	#	~	RG	B	Operation	LH	AH	I	S	T	N	Z	V	C	RMW
NEG A	1	2	0	0	byte (A) ← 0 – (A)	X	-	-	-	-	*	*	*	*	-
NEG ear	2	3	2	0	byte (ear) ← 0 – (ear)	-	-	-	-	-	*	*	*	*	-
NEG eam	2+	5+ (a)	0	2× (b)	byte (eam) ← 0 – (eam)	-	-	-	-	-	*	*	*	*	*
NEGW A	1	2	0	0	word (A) ← 0 – (A)	-	-	-	-	-	*	*	*	*	-
NEGW ear	2	3	2	0	word (ear) ← 0 – (ear)	-	-	-	-	-	*	*	*	*	-
NEGW eam	2+	5+ (a)	0	2× (c)	word (eam) ← 0 – (eam)	-	-	-	-	-	*	*	*	*	*

Note : For an explanation of “(a)” to “(d)”, refer to Table 4, “Number of Execution Cycles for Each Type of Addressing,” and Table 5, “Correction Values for Number of Cycles Used to Calculate Number of Actual Cycles.”

Table 17 Normalize Instruction (Long Word) [1 Instruction]

Mnemonic	#	~	RG	B	Operation	LH	AH	I	S	T	N	Z	V	C	RMW
NRML A, R0	2	*1	1	0	long (A) ← Shift until first digit is “1” byte (R0) ← Current shift count	-	-	-	-	-	-	*	-	-	-

*1: 4 when the contents of the accumulator are all zeroes, 6 + (R0) in all other cases (shift count).

Note : For an explanation of “(a)” to “(d)”, refer to Table 4, “Number of Execution Cycles for Each Type of Addressing,” and Table 5, “Correction Values for Number of Cycles Used to Calculate Number of Actual Cycles.”

Table 18 Shift Instructions (Byte/Word/Long Word) [18 Instructions]

Mnemonic	#	~	RG	B	Operation	LH	AH	I	S	T	N	Z	V	C	RMW
RORC A	2	2	0	0	byte (A) ← Right rotation with carry	—	—	—	—	—	*	*	—	*	—
ROLC A	2	2	0	0	byte (A) ← Left rotation with carry	—	—	—	—	—	*	*	—	*	—
RORC ear	2	3	2	0	byte (ear) ← Right rotation with carry	—	—	—	—	—	*	*	—	*	—
RORC eam	2+	5+ (a)	0	2× (b)	byte (eam) ← Right rotation with carry	—	—	—	—	—	*	*	—	*	*
ROLC ear	2	3	2	0	byte (ear) ← Left rotation with carry	—	—	—	—	—	*	*	—	*	—
ROLC eam	2+	5+ (a)	0	2× (b)	byte (eam) ← Left rotation with carry	—	—	—	—	—	*	*	—	*	*
ASR A, R0	2	*1	1	0	byte (A) ← Arithmetic right barrel shift (A, R0)	—	—	—	—	*	*	*	—	*	—
LSR A, R0	2	*1	1	0	byte (A) ← Logical right barrel shift (A, R0)	—	—	—	—	*	*	*	—	*	—
LSL A, R0	2	*1	1	0	byte (A) ← Logical left barrel shift (A, R0)	—	—	—	—	—	*	*	—	*	—
ASRWA	1	2	0	0	word (A) ← Arithmetic right shift (A, 1 bit)	—	—	—	—	*	*	*	—	*	—
LSRW A/SHRW A	1	2	0	0	word (A) ← Logical right shift (A, 1 bit)	—	—	—	—	*	R	*	—	*	—
LSLW A/SHLW A	1	2	0	0	word (A) ← Logical left shift (A, 1 bit)	—	—	—	—	—	*	*	—	*	—
ASRW A, R0	2	*1	1	0	word (A) ← Arithmetic right barrel shift (A, R0)	—	—	—	—	*	*	*	—	*	—
LSRW A, R0	2	*1	1	0	word (A) ← Logical right barrel shift (A, R0)	—	—	—	—	*	*	*	—	*	—
LSLW A, R0	2	*1	1	0	word (A) ← Logical left barrel shift (A, R0)	—	—	—	—	—	*	*	—	*	—
ASRL A, R0	2	*2	1	0	long (A) ← Arithmetic right shift (A, R0)	—	—	—	—	*	*	*	—	*	—
LSRL A, R0	2	*2	1	0	long (A) ← Logical right barrel shift (A, R0)	—	—	—	—	*	*	*	—	*	—
LSLL A, R0	2	*2	1	0	long (A) ← Logical left barrel shift (A, R0)	—	—	—	—	—	*	*	—	*	—

*1: 6 when R0 is 0, 5 + (R0) in all other cases.

*2: 6 when R0 is 0, 6 + (R0) in all other cases.

Note : For an explanation of “(a)” to “(d)”, refer to Table 4, “Number of Execution Cycles for Each Type of Addressing,” and Table 5, “Correction Values for Number of Cycles Used to Calculate Number of Actual Cycles.”

MB90580B Series

Table 19 Branch 1 Instructions [31 Instructions]

Mnemonic	#	~	RG	B	Operation	LH	AH	I	S	T	N	Z	V	C	RMW
BZ/BEQ rel	2	*1	0	0	Branch when (Z) = 1	-	-	-	-	-	-	-	-	-	-
BNZ/BNE rel	2	*1	0	0	Branch when (Z) = 0	-	-	-	-	-	-	-	-	-	-
BC/BLO rel	2	*1	0	0	Branch when (C) = 1	-	-	-	-	-	-	-	-	-	-
BNC/BHS rel	2	*1	0	0	Branch when (C) = 0	-	-	-	-	-	-	-	-	-	-
BN rel	2	*1	0	0	Branch when (N) = 1	-	-	-	-	-	-	-	-	-	-
BP rel	2	*1	0	0	Branch when (N) = 0	-	-	-	-	-	-	-	-	-	-
BV rel	2	*1	0	0	Branch when (V) = 1	-	-	-	-	-	-	-	-	-	-
BNV rel	2	*1	0	0	Branch when (V) = 0	-	-	-	-	-	-	-	-	-	-
BT rel	2	*1	0	0	Branch when (T) = 1	-	-	-	-	-	-	-	-	-	-
BNT rel	2	*1	0	0	Branch when (T) = 0	-	-	-	-	-	-	-	-	-	-
BLT rel	2	*1	0	0	Branch when (V) xor (N) = 1	-	-	-	-	-	-	-	-	-	-
BGE rel	2	*1	0	0	Branch when (V) xor (N) = 0	-	-	-	-	-	-	-	-	-	-
BLE rel	2	*1	0	0	Branch when ((V) xor (N)) or (Z) = 1	-	-	-	-	-	-	-	-	-	-
BGT rel	2	*1	0	0	Branch when ((V) xor (N)) or (Z) = 0	-	-	-	-	-	-	-	-	-	-
BLS rel	2	*1	0	0	Branch when (C) or (Z) = 1	-	-	-	-	-	-	-	-	-	-
BHI rel	2	*1	0	0	Branch when (C) or (Z) = 0	-	-	-	-	-	-	-	-	-	-
BRA rel	2	*1	0	0	Branch unconditionally	-	-	-	-	-	-	-	-	-	-
JMP @A	1	2	0	0	word (PC) ← (A)	-	-	-	-	-	-	-	-	-	-
JMP addr16	3	3	0	0	word (PC) ← addr16	-	-	-	-	-	-	-	-	-	-
JMP @ear	2	3	1	0	word (PC) ← (ear)	-	-	-	-	-	-	-	-	-	-
JMP @eam	2+	4+ (a)	0	(c)	word (PC) ← (eam)	-	-	-	-	-	-	-	-	-	-
JMPP @ear *3	2	5	2	0	word (PC) ← (ear), (PCB) ← (ear +2)	-	-	-	-	-	-	-	-	-	-
JMPP @eam *3	2+	6+ (a)	0	(d)	word (PC) ← (eam), (PCB) ← (eam +2)	-	-	-	-	-	-	-	-	-	-
JMPP addr24	4	4	0	0	word (PC) ← ad24 0 to 15, (PCB) ← ad24 16 to 23	-	-	-	-	-	-	-	-	-	-
CALL @ear *4	2	6	1	(c)	word (PC) ← (ear)	-	-	-	-	-	-	-	-	-	-
CALL @eam *4	2+	7+ (a)	0	2× (c)	word (PC) ← (eam)	-	-	-	-	-	-	-	-	-	-
CALL addr16 *5	3	6	0	(c)	word (PC) ← addr16	-	-	-	-	-	-	-	-	-	-
CALLV #vct4 *5	1	7	0	2× (c)	Vector call instruction	-	-	-	-	-	-	-	-	-	-
CALLP @ear *6	2	10	2	2× (c)	word (PC) ← (ear) 0 to 15, (PCB) ← (ear) 16 to 23	-	-	-	-	-	-	-	-	-	-
CALLP @eam *6	2+	11+ (a)	0	*2	word (PC) ← (eam) 0 to 15, (PCB) ← (eam) 16 to 23	-	-	-	-	-	-	-	-	-	-
CALLP addr24 *7	4	10	0	2× (c)	word (PC) ← addr0 to 15, (PCB) ← addr16 to 23	-	-	-	-	-	-	-	-	-	-

*1: 4 when branching, 3 when not branching.

*2: (b) + 3 × (c)

*3: Read (word) branch address.

*4: W: Save (word) to stack; R: read (word) branch address.

*5: Save (word) to stack.

*6: W: Save (long word) to W stack; R: read (long word) R branch address.

*7: Save (long word) to stack.

Note : For an explanation of "(a)" to "(d)", refer to Table 4, "Number of Execution Cycles for Each Type of Addressing," and Table 5, "Correction Values for Number of Cycles Used to Calculate Number of Actual Cycles."

Table 20 Branch 2 Instructions [19 Instructions]

Mnemonic	#	~	RG	B	Operation	LH	AH	I	S	T	N	Z	V	C	RMW
CBNE A, #imm8, rel	3	*1	0	0	Branch when byte (A) ≠ imm8	–	–	–	–	–	*	*	*	*	–
CWBNE A, #imm16, rel	4	*1	0	0	Branch when word (A) ≠ imm16	–	–	–	–	–	*	*	*	*	–
CBNE ear, #imm8, rel	4	*2	1	0	Branch when byte (ear) ≠ imm8	–	–	–	–	–	*	*	*	*	–
CBNE eam, #imm8, rel*10	4+	*3	0	(b)	Branch when byte (eam) ≠ imm8	–	–	–	–	–	*	*	*	*	–
CWBNE ear, #imm16, rel	5	*4	1	0	Branch when word (ear) ≠ imm16	–	–	–	–	–	*	*	*	*	–
CWBNE eam, #imm16, rel*10	5+	*3	0	(c)	Branch when word (eam) ≠ imm16	–	–	–	–	–	*	*	*	*	–
DBNZ ear, rel	3	*5	2	0	Branch when byte (ear) = (ear) – 1, and (ear) ≠ 0	–	–	–	–	–	*	*	*	–	–
DBNZ eam, rel	3+	*6	2	2× (b)	Branch when byte (eam) = (eam) – 1, and (eam) ≠ 0	–	–	–	–	–	*	*	*	–	*
DWBNZ ear, rel	3	*5	2	0	Branch when word (ear) = (ear) – 1, and (ear) ≠ 0	–	–	–	–	–	*	*	*	–	–
DWBNZ eam, rel	3+	*6	2	2× (c)	Branch when word (eam) = (eam) – 1, and (eam) ≠ 0	–	–	–	–	–	*	*	*	–	*
INT #vct8	2	20	0	8× (c)	Software interrupt	–	–	R	S	–	–	–	–	–	–
INT addr16	3	16	0	6× (c)	Software interrupt	–	–	R	S	–	–	–	–	–	–
INTP addr24	4	17	0	6× (c)	Software interrupt	–	–	R	S	–	–	–	–	–	–
INT9	1	20	0	8× (c)	Software interrupt	–	–	R	S	–	–	–	–	–	–
RETI	1	15	0	*7	Return from interrupt	–	–	*	*	*	*	*	*	*	–
LINK #imm8	2	6	0	(c)	At constant entry, save old frame pointer to stack, set new frame pointer, and allocate local pointer area	–	–	–	–	–	–	–	–	–	–
UNLINK	1	5	0	(c)	At constant entry, retrieve old frame pointer from stack.	–	–	–	–	–	–	–	–	–	–
RET *8	1	4	0	(c)	Return from subroutine	–	–	–	–	–	–	–	–	–	–
RETP *9	1	6	0	(d)	Return from subroutine	–	–	–	–	–	–	–	–	–	–

- *1: 5 when branching, 4 when not branching
- *2: 13 when branching, 12 when not branching
- *3: 7 + (a) when branching, 6 + (a) when not branching
- *4: 8 when branching, 7 when not branching
- *5: 7 when branching, 6 when not branching
- *6: 8 + (a) when branching, 7 + (a) when not branching
- *7: Set to 3 × (b) + 2 × (c) when an interrupt request occurs, and 6 × (c) for return.
- *8: Retrieve (word) from stack
- *9: Retrieve (long word) from stack
- *10: In the CBNE/CWBNE instruction, do not use the RWj+ addressing mode.

Note : For an explanation of “(a)” to “(d)”, refer to Table 4, “Number of Execution Cycles for Each Type of Addressing,” and Table 5, “Correction Values for Number of Cycles Used to Calculate Number of Actual Cycles.”

MB90580B Series

Table 21 Other Control Instructions (Byte/Word/Long Word) [28 Instructions]

Mnemonic	#	~	RG	B	Operation	LH	AH	I	S	T	N	Z	V	C	RMW
PUSHW A	1	4	0	(c)	word (SP) ← (SP) -2, ((SP)) ← (A)	-	-	-	-	-	-	-	-	-	-
PUSHW AH	1	4	0	(c)	word (SP) ← (SP) -2, ((SP)) ← (AH)	-	-	-	-	-	-	-	-	-	-
PUSHW PS	1	4	0	(c)	word (SP) ← (SP) -2, ((SP)) ← (PS)	-	-	-	-	-	-	-	-	-	-
PUSHW rlst	2	*3	*5	*4	(SP) ← (SP) -2n, ((SP)) ← (rlst)	-	-	-	-	-	-	-	-	-	-
POPW A	1	3	0	(c)	word (A) ← ((SP)), (SP) ← (SP) +2	-	*	-	-	-	-	-	-	-	-
POPW AH	1	3	0	(c)	word (AH) ← ((SP)), (SP) ← (SP) +2	-	-	-	-	-	-	-	-	-	-
POPW PS	1	4	0	(c)	word (PS) ← ((SP)), (SP) ← (SP) +2	-	-	*	*	*	*	*	*	*	-
POPW rlst	2	*2	*5	*4	(rlst) ← ((SP)), (SP) ← (SP) +2n	-	-	-	-	-	-	-	-	-	-
JCTX @A	1	14	0	6× (c)	Context switch instruction	-	-	*	*	*	*	*	*	*	-
AND CCR, #imm8	2	3	0	0	byte (CCR) ← (CCR) and imm8	-	-	*	*	*	*	*	*	*	-
OR CCR, #imm8	2	3	0	0	byte (CCR) ← (CCR) or imm8	-	-	*	*	*	*	*	*	*	-
MOV RP, #imm8	2	2	0	0	byte (RP) ← imm8	-	-	-	-	-	-	-	-	-	-
MOV ILM, #imm8	2	2	0	0	byte (ILM) ← imm8	-	-	-	-	-	-	-	-	-	-
MOVEA RWi, ear	2	3	1	0	word (RWi) ← ear	-	-	-	-	-	-	-	-	-	-
MOVEA RWi, eam	2+	2+ (a)	1	0	word (RWi) ← eam	-	-	-	-	-	-	-	-	-	-
MOVEA A, ear	2	1	0	0	word (A) ← ear	-	*	-	-	-	-	-	-	-	-
MOVEA A, eam	2+	1+ (a)	0	0	word (A) ← eam	-	*	-	-	-	-	-	-	-	-
ADDSP #imm8	2	3	0	0	word (SP) ← (SP) +ext (imm8)	-	-	-	-	-	-	-	-	-	-
ADDSP #imm16	3	3	0	0	word (SP) ← (SP) +imm16	-	-	-	-	-	-	-	-	-	-
MOV A, brgl	2	*1	0	0	byte (A) ← (brgl)	Z	*	-	-	-	*	*	-	-	-
MOV brg2, A	2	1	0	0	byte (brg2) ← (A)	-	-	-	-	-	*	*	-	-	-
NOP	1	1	0	0	No operation	-	-	-	-	-	-	-	-	-	-
ADB	1	1	0	0	Prefix code for accessing AD space	-	-	-	-	-	-	-	-	-	-
DTB	1	1	0	0	Prefix code for accessing DT space	-	-	-	-	-	-	-	-	-	-
PCB	1	1	0	0	Prefix code for accessing PC space	-	-	-	-	-	-	-	-	-	-
SPB	1	1	0	0	Prefix code for accessing SP space	-	-	-	-	-	-	-	-	-	-
NCC	1	1	0	0	Prefix code for no flag change	-	-	-	-	-	-	-	-	-	-
CMR	1	1	0	0	Prefix code for common register bank	-	-	-	-	-	-	-	-	-	-

*1: PCB, ADB, SSB, USB, and SPB : 1 state
DTB, DPR : 2 states

*2: $7 + 3 \times (\text{pop count}) + 2 \times (\text{last register number to be popped})$, 7 when rlst = 0 (no transfer register)

*3: $29 + 3 \times (\text{push count}) - 3 \times (\text{last register number to be pushed})$, 8 when rlst = 0 (no transfer register)

*4: Pop count × (c), or push count × (c)

*5: Pop count or push count.

Note : For an explanation of “(a)” to “(d)”, refer to Table 4, “Number of Execution Cycles for Each Type of Addressing,” and Table 5, “Correction Values for Number of Cycles Used to Calculate Number of Actual Cycles.”

Table 22 Bit Manipulation Instructions [21 Instructions]

Mnemonic	#	~	RG	B	Operation	LH	AH	I	S	T	N	Z	V	C	RMW
MOVB A, dir:bp	3	5	0	(b)	byte (A) ← (dir:bp) b	Z	*	–	–	–	*	*	–	–	–
MOVB A, addr16:bp	4	5	0	(b)	byte (A) ← (addr16:bp) b	Z	*	–	–	–	*	*	–	–	–
MOVB A, io:bp	3	4	0	(b)	byte (A) ← (io:bp) b	Z	*	–	–	–	*	*	–	–	–
MOVB dir:bp, A	3	7	0	2× (b)	bit (dir:bp) b ← (A)	–	–	–	–	–	*	*	–	–	*
MOVB addr16:bp, A	4	7	0	2× (b)	bit (addr16:bp) b ← (A)	–	–	–	–	–	*	*	–	–	*
MOVB io:bp, A	3	6	0	2× (b)	bit (io:bp) b ← (A)	–	–	–	–	–	*	*	–	–	*
SETB dir:bp	3	7	0	2× (b)	bit (dir:bp) b ← 1	–	–	–	–	–	–	–	–	–	*
SETB addr16:bp	4	7	0	2× (b)	bit (addr16:bp) b ← 1	–	–	–	–	–	–	–	–	–	*
SETB io:bp	3	7	0	2× (b)	bit (io:bp) b ← 1	–	–	–	–	–	–	–	–	–	*
CLRB dir:bp	3	7	0	2× (b)	bit (dir:bp) b ← 0	–	–	–	–	–	–	–	–	–	*
CLRB addr16:bp	4	7	0	2× (b)	bit (addr16:bp) b ← 0	–	–	–	–	–	–	–	–	–	*
CLRB io:bp	3	7	0	2× (b)	bit (io:bp) b ← 0	–	–	–	–	–	–	–	–	–	*
BBC dir:bp, rel	4	*1	0	(b)	Branch when (dir:bp) b = 0	–	–	–	–	–	–	*	–	–	–
BBC addr16:bp, rel	5	*1	0	(b)	Branch when (addr16:bp) b = 0	–	–	–	–	–	–	*	–	–	–
BBC io:bp, rel	4	*2	0	(b)	Branch when (io:bp) b = 0	–	–	–	–	–	–	*	–	–	–
BBS dir:bp, rel	4	*1	0	(b)	Branch when (dir:bp) b = 1	–	–	–	–	–	–	*	–	–	–
BBS addr16:bp, rel	5	*1	0	(b)	Branch when (addr16:bp) b = 1	–	–	–	–	–	–	*	–	–	–
BBS io:bp, rel	4	*2	0	(b)	Branch when (io:bp) b = 1	–	–	–	–	–	–	*	–	–	–
SBBS addr16:bp, rel	5	*3	0	2× (b)	Branch when (addr16:bp) b = 1, bit = 1	–	–	–	–	–	–	*	–	–	*
WBTS io:bp	3	*4	0	*5	Wait until (io:bp) b = 1	–	–	–	–	–	–	–	–	–	–
WBTC io:bp	3	*4	0	*5	Wait until (io:bp) b = 0	–	–	–	–	–	–	–	–	–	–

- *1: 8 when branching, 7 when not branching
- *2: 7 when branching, 6 when not branching
- *3: 10 when condition is satisfied, 9 when not satisfied
- *4: Undefined count
- *5: Until condition is satisfied

Note : For an explanation of “(a)” to “(d)”, refer to Table 4, “Number of Execution Cycles for Each Type of Addressing,” and Table 5, “Correction Values for Number of Cycles Used to Calculate Number of Actual Cycles.”

Table 23 Accumulator Manipulation Instructions (Byte/Word) [6 Instructions]

Mnemonic	#	~	RG	B	Operation	LH	AH	I	S	T	N	Z	V	C	RMW
SWAP	1	3	0	0	byte (A) 0 to 7 ↔ (A) 8 to 15	–	–	–	–	–	–	–	–	–	–
SWAPW/XCHW A,T	1	2	0	0	word (AH) ↔ (AL)	–	*	–	–	–	–	–	–	–	–
EXT	1	1	0	0	byte sign extension	X	–	–	–	–	*	*	–	–	–
EXTW	1	2	0	0	word sign extension	–	X	–	–	–	*	*	–	–	–
ZEXT	1	1	0	0	byte zero extension	Z	–	–	–	–	R	*	–	–	–
ZEXTW	1	1	0	0	word zero extension	–	Z	–	–	–	R	*	–	–	–

Note: For an explanation of “(a)” to “(d)”, refer to Table 4, “Number of Execution Cycles for Each Type of Addressing,” and Table 5, “Correction Values for Number of Cycles Used to Calculate Number of Actual Cycles.”

MB90580B Series

Table 24 String Instructions [10 Instructions]

Mnemonic	#	~	RG	B	Operation	LH	AH	I	S	T	N	Z	V	C	RMW
MOVS/MOVS	2	*2	*5	*3	Byte transfer @AH+ ← @AL+, counter = RW0	—	—	—	—	—	—	—	—	—	—
MOVSD	2	*2	*5	*3	Byte transfer @AH- ← @AL-, counter = RW0	—	—	—	—	—	—	—	—	—	—
SCEQ/SCEQI	2	*1	*5	*4	Byte retrieval (@AH+) – AL, counter = RW0	—	—	—	—	—	*	*	*	*	—
SCEQD	2	*1	*5	*4	Byte retrieval (@AH-) – AL, counter = RW0	—	—	—	—	—	*	*	*	*	—
FISL/FILSI	2	6m +6	*5	*3	Byte filling @AH+ ← AL, counter = RW0	—	—	—	—	—	*	*	—	—	—
MOVSW/MOVSWI	2	*2	*8	*6	Word transfer @AH+ ← @AL+, counter = RW0	—	—	—	—	—	—	—	—	—	—
MOVSD	2	*2	*8	*6	Word transfer @AH- ← @AL-, counter = RW0	—	—	—	—	—	—	—	—	—	—
SCWEQ/SCWEQI	2	*1	*8	*7	Word retrieval (@AH+) – AL, counter = RW0	—	—	—	—	—	*	*	*	*	—
SCWEQD	2	*1	*8	*7	Word retrieval (@AH-) – AL, counter = RW0	—	—	—	—	—	*	*	*	*	—
FILSW/FILSWI	2	6m +6	*8	*6	Word filling @AH+ ← AL, counter = RW0	—	—	—	—	—	*	*	—	—	—

m: RW0 value (counter value)

n: Loop count

*1: 5 when RW0 is 0, $4 + 7 \times (RW0)$ for count out, and $7 \times n + 5$ when match occurs

*2: 5 when RW0 is 0, $4 + 8 \times (RW0)$ in any other case

*3: $(b) \times (RW0) + (b) \times (RW0)$ when accessing different areas for the source and destination, calculate (b) separately for each.

*4: $(b) \times n$

*5: $2 \times (RW0)$

*6: $(c) \times (RW0) + (c) \times (RW0)$ when accessing different areas for the source and destination, calculate (c) separately for each.

*7: $(c) \times n$

*8: $2 \times (RW0)$

Note : For an explanation of “(a)” to “(d)”, refer to Table 4, “Number of Execution Cycles for Each Type of Addressing,” and Table 5, “Correction Values for Number of Cycles Used to Calculate Number of Actual Cycles.”

MB90580B Series

■ ORDERING INFORMATION

Part number	Package	Remarks
MB90F583BPFV MB90583BPFV MB90587PFV	100-pin Plastic LQFP (FPT-100P-M05)	
MB90F583BPF MB90583BPF MB90587PF	100-pin Plastic QFP (FPT-100P-M06)	

MB90580B Series

PACKAGE DIMENSIONS

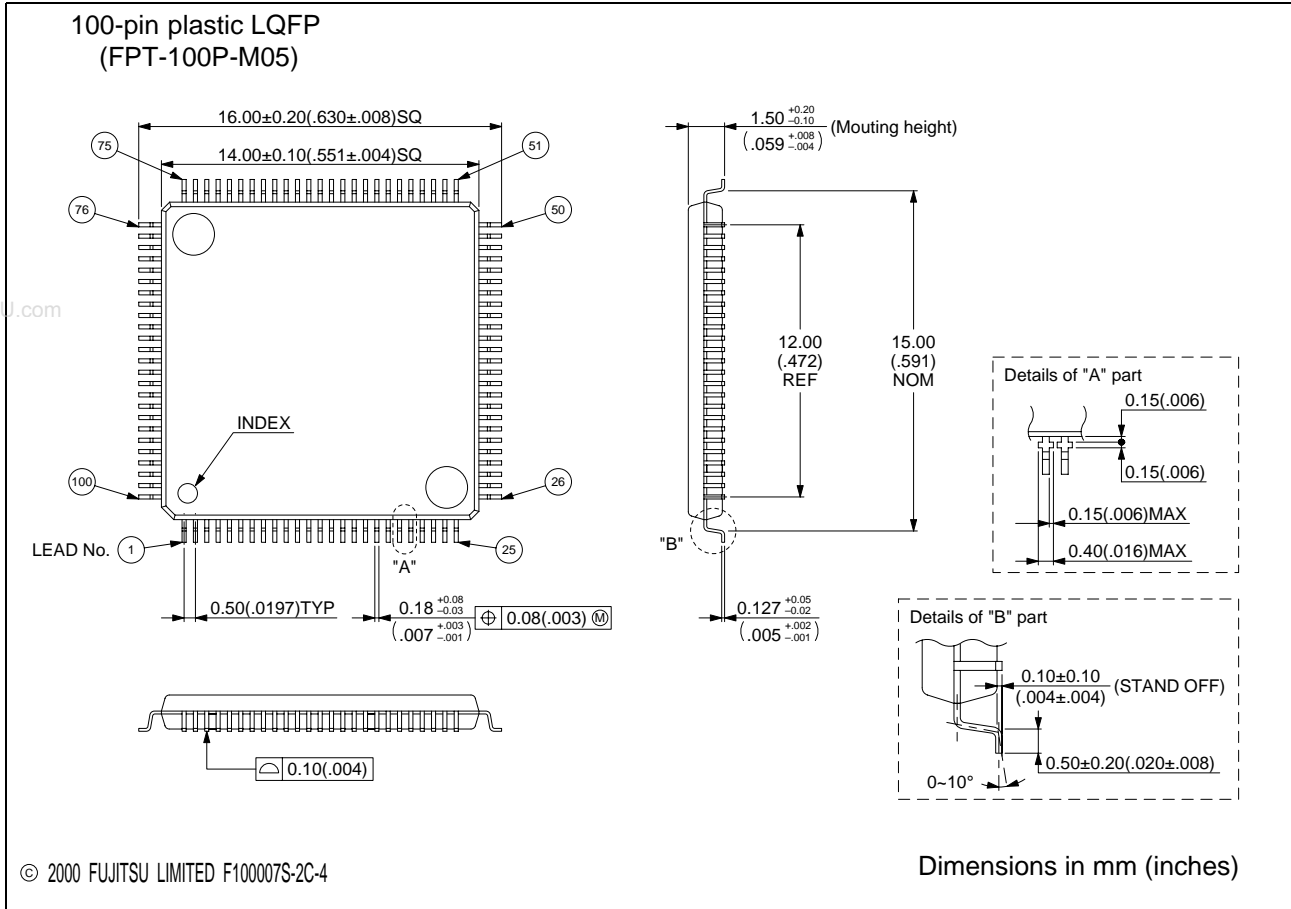

Note : The external dimensions show here are for reference only.
For official dimensions, contact a FUJITSU representative.

MB90580B Series

100-pin plastic QFP (FPT-100P-M06)

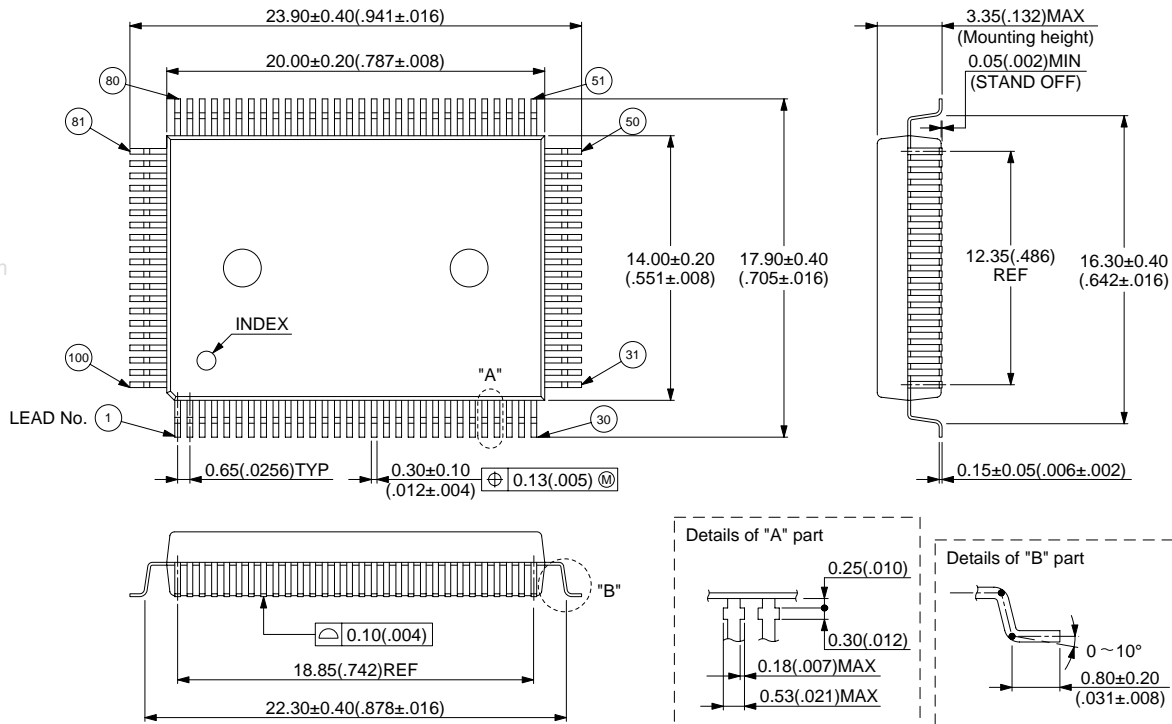

© 2000 FUJITSU LIMITED F100008-3C-3

Dimensions in mm (inches)

Note : The external dimensions show here are for reference only.
For official dimensions, contact a FUJITSU representative.

FUJITSU LIMITED

For further information please contact:

Japan

FUJITSU LIMITED
Corporate Global Business Support Division
Electronic Devices
Shinjuku Dai-Ichi Seimei Bldg. 7-1,
Nishishinjuku 2-chome, Shinjuku-ku,
Tokyo 163-0721, Japan
Tel: +81-3-5322-3347
Fax: +81-3-5322-3386

<http://edevic.fujitsu.com/>

North and South America

FUJITSU MICROELECTRONICS, INC.
3545 North First Street,
San Jose, CA 95134-1804, U.S.A.
Tel: +1-408-922-9000
Fax: +1-408-922-9179

Customer Response Center
Mon. - Fri.: 7 am - 5 pm (PST)
Tel: +1-800-866-8608
Fax: +1-408-922-9179

<http://www.fujitsumicro.com/>

Europe

FUJITSU MICROELECTRONICS EUROPE GmbH
Am Siebenstein 6-10,
D-63303 Dreieich-Buchsschlag,
Germany
Tel: +49-6103-690-0
Fax: +49-6103-690-122

<http://www.fujitsu-fme.com/>

Asia Pacific

FUJITSU MICROELECTRONICS ASIA PTE. LTD.
#05-08, 151 Lorong Chuan,
New Tech Park,
Singapore 556741
Tel: +65-281-0770
Fax: +65-281-0220

<http://www.fmap.com.sg/>

Korea

FUJITSU MICROELECTRONICS KOREA LTD.
1702 KOSMO TOWER, 1002 Daechi-Dong,
Kangnam-Gu, Seoul 135-280
Korea
Tel: +82-2-3484-7100
Fax: +82-2-3484-7111

F0010

© FUJITSU LIMITED Printed in Japan

All Rights Reserved.

The contents of this document are subject to change without notice. Customers are advised to consult with FUJITSU sales representatives before ordering.

The information and circuit diagrams in this document are presented as examples of semiconductor device applications, and are not intended to be incorporated in devices for actual use. Also, FUJITSU is unable to assume responsibility for infringement of any patent rights or other rights of third parties arising from the use of this information or circuit diagrams.

The contents of this document may not be reproduced or copied without the permission of FUJITSU LIMITED.

FUJITSU semiconductor devices are intended for use in standard applications (computers, office automation and other office equipments, industrial, communications, and measurement equipments, personal or household devices, etc.).

CAUTION:

Customers considering the use of our products in special applications where failure or abnormal operation may directly affect human lives or cause physical injury or property damage, or where extremely high levels of reliability are demanded (such as aerospace systems, atomic energy controls, sea floor repeaters, vehicle operating controls, medical devices for life support, etc.) are requested to consult with FUJITSU sales representatives before such use. The company will not be responsible for damages arising from such use without prior approval.

Any semiconductor devices have inherently a certain rate of failure. You must protect against injury, damage or loss from such failures by incorporating safety design measures into your facility and equipment such as redundancy, fire protection, and prevention of over-current levels and other abnormal operating conditions.

If any products described in this document represent goods or technologies subject to certain restrictions on export under the Foreign Exchange and Foreign Trade Control Law of Japan, the prior authorization by Japanese government should be required for export of those products from Japan.