

N-Channel Enhancement-Mode MOSFET

V_{DS} 30V R_{DS(ON)} 11mΩ I_D 60A

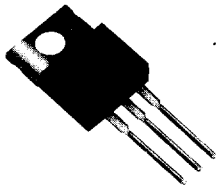

TRENCH GENFET
New Product

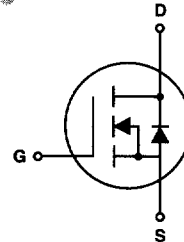

TO-220AB

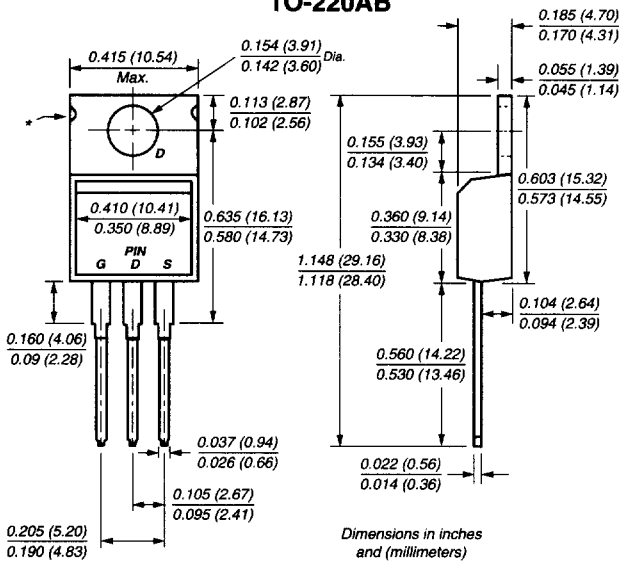

* May be notched or flat

Features

- Advanced Trench Process Technology
- High Density Cell Design for Ultra Low On-Resistance
- Specially Designed for Low Voltage DC/DC Converters
- Fast Switching for High Efficiency

Mechanical Data

Case: JEDEC TO-220AB molded plastic body

Terminals: Leads solderable per MIL-STD-750, Method 2026

High temperature soldering guaranteed: 250°C/10 seconds at terminals

Mounting Torque: 10 in-lbs maximum

Weight: 2.0g

Maximum Ratings and Thermal Characteristics (T_C = 25°C unless otherwise noted)

Parameter	Symbol	Limit	Unit
Drain-Source Voltage	V _{DS}	30	V
Gate-Source Voltage	V _{GS}	±20	
Continuous Drain Current ⁽¹⁾	I _D	60	A
Pulsed Drain Current	I _{DM}	100	
Maximum Power Dissipation	P _D	T _C = 25°C	62.5
		T _C = 100°C	25
Operating Junction and Storage Temperature Range	T _J , T _{stg}	-55 to 150	°C
Lead Temperature (1/8" from case for 5 sec.)	T _L	275	°C
Junction-to-Case Thermal Resistance	R _{θJC}	2.0	°C/W
Junction-to-Ambient Thermal Resistance	R _{θJA}	62.5	°C/W

Notes: (1) Maximum DC current limited by the package

N-Channel Enhancement-Mode MOSFET

Electrical Characteristics (T_J = 25°C unless otherwise noted)

Parameter	Symbol	Test Condition	Min	Typ	Max	Unit
Static						
Drain-Source Breakdown Voltage	BV _{DSS}	V _{GS} = 0V, I _D = 250μA	30			V
Gate Threshold Voltage	V _{GS(th)}	V _{DS} = V _{GS} , I _D = 250μA	1.0		3.0	V
Gate-Body Leakage	I _{GSS}	V _{DS} = 0V, V _{GS} = ±20V			±100	nA
Zero Gate Voltage Drain Current	I _{DSS}	V _{DS} = 30V, V _{GS} = 0V			1	μA
On-State Drain Current ⁽¹⁾	I _{D(on)}	V _{DS} ≥ 5V, V _{GS} = 10V	60			A
Drain-Source On-State Resistance ⁽¹⁾	R _{DS(on)}	V _{GS} = 10V, I _D = 30A		9	11	mΩ
		V _{GS} = 4.5V, I _D = 25A		13	16	
Forward Transconductance ⁽¹⁾	g _{fs}	V _{DS} = 10V, I _D = 25A		40		S
Diode Forward Voltage	V _{SD}	I _S = 25A, V _{GS} = 0V		0.9	1.3	V
Dynamic⁽¹⁾						
Total Gate Charge	Q _g	V _{DS} = 15V, V _{GS} = 5V, I _D = 50A		16	22	nC
				35	60	
				8		
Gate-Source Charge	Q _{gs}	V _{DS} = 15V, V _{GS} = 10V I _D = 50A		8		nC
Gate-Drain Charge	Q _{gd}			6		
Turn-On Delay Time	t _{d(on)}	V _{DD} = 15V, R _L = 15Ω I _D ≈ 1A, V _{GEN} = 10V R _G = 6Ω		11	20	ns
Rise Time	t _r			11	20	
Turn-Off Delay Time	t _{d(off)}			48	80	
Fall Time	t _f			15	30	
Input Capacitance	C _{iss}	V _{GS} = 0V	–	1850	–	pF
Output Capacitance	C _{oss}	V _{DS} = 15V	–	315	–	
Reverse Transfer Capacitance	C _{rss}	f = 1.0MHz	–	145	–	
Source-Drain Reverse Recovery Time	t _{rr}	I _F = 25A, di/dt = 100A/μs		160		ns

Note:

(1) Pulse test; pulse width ≤ 300 μs, duty cycle ≤ 2%

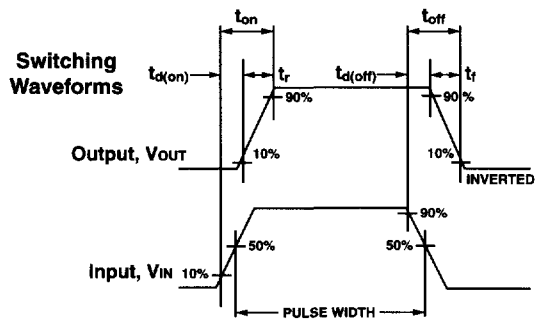
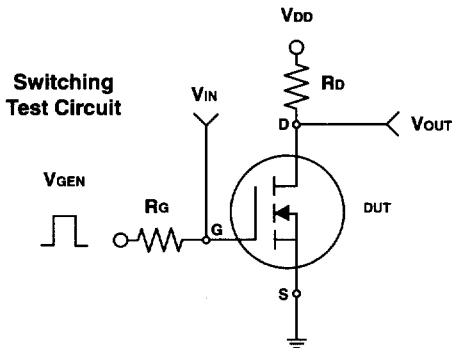

T0-22AB, T0-263, T0-252

N-Channel Enhancement-Mode MOSFET

Ratings and Characteristic Curves ($T_A = 25^\circ\text{C}$ unless otherwise noted)

Fig. 1 – Output Characteristics

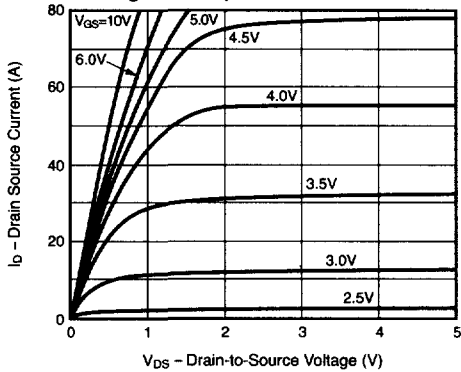

Fig. 2 – Transfer Characteristics

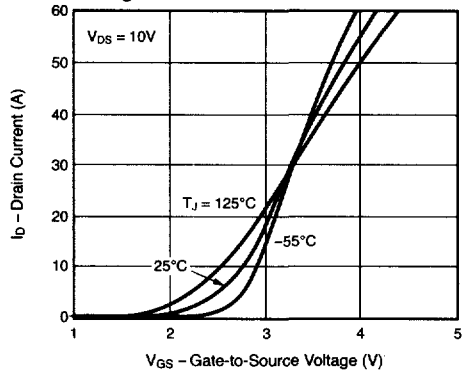

Fig. 3 – Threshold Voltage vs. Temperature

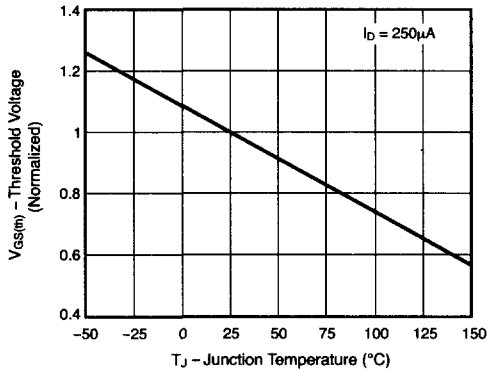

Fig. 4 – On-Resistance vs. Drain Current

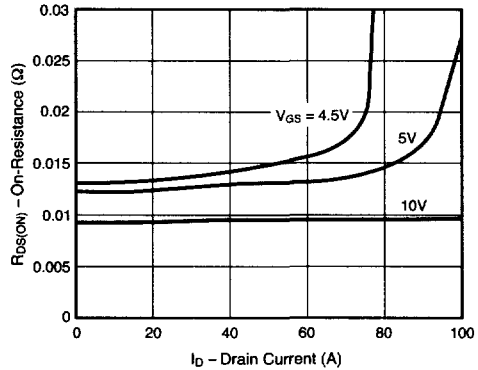
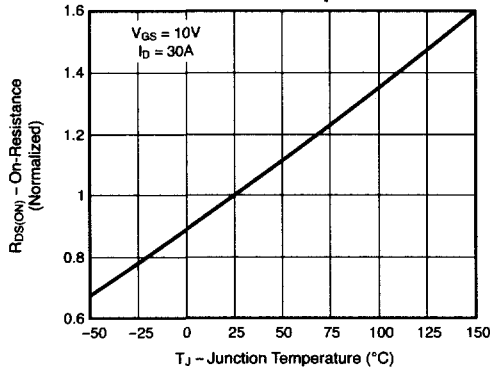

Fig. 5 – On-Resistance vs. Junction Temperature



N-Channel Enhancement-Mode MOSFET

Ratings and Characteristic Curves (T_A = 25°C unless otherwise noted)

Fig. 6 – On-Resistance vs. Gate-to-Source Voltage

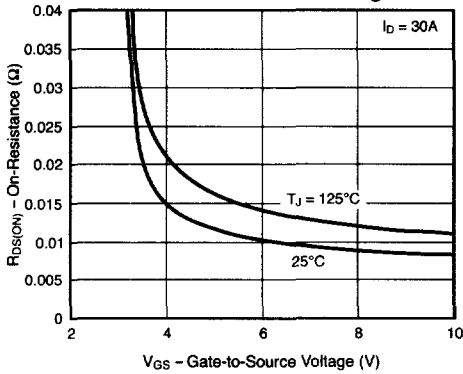

Fig. 7 – Gate Charge

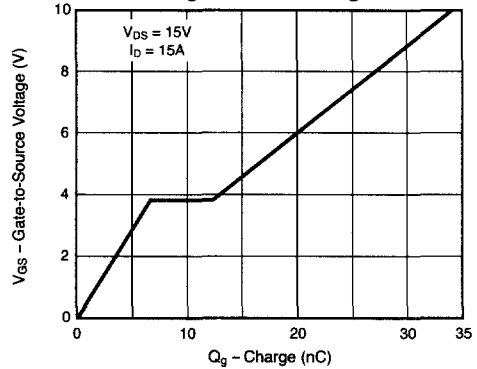

Fig. 8 – Capacitance

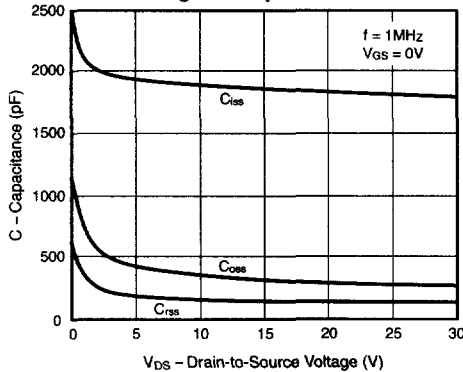
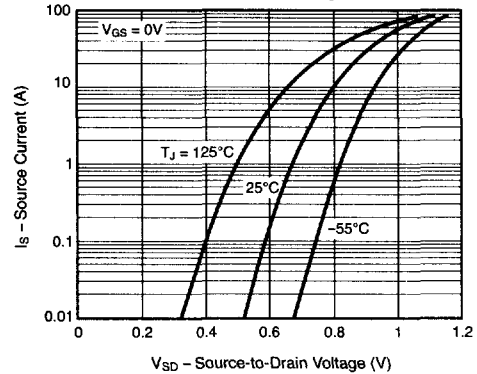

Fig. 9 – Source-Drain Diode Forward Voltage



T0-22AB, T0-263, T0-252

N-Channel Enhancement-Mode MOSFET

Ratings and Characteristic Curves (T_A = 25°C unless otherwise noted)

Fig. 10 – Breakdown Voltage vs. Junction Temperature

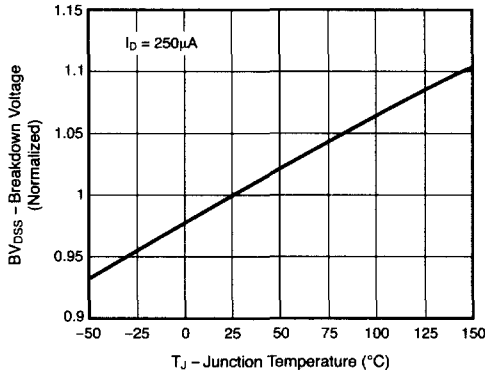

Fig. 11 – Transient Thermal Impedance

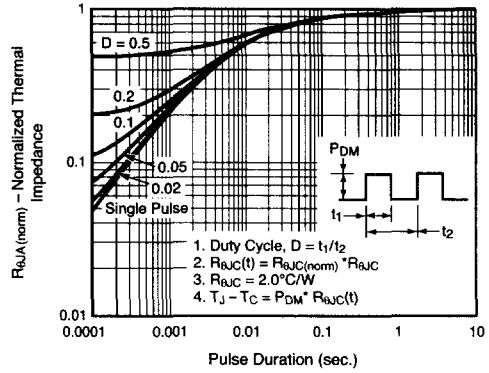

Fig. 12 – Power vs. Pulse Duration

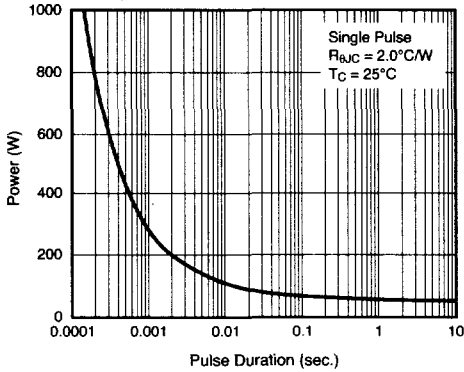

Fig. 13 – Maximum Safe Operating Area

