

**Circuits  
from the Lab™**

### Circuit Designs Using Analog Devices Products

Apply these product pairings quickly and with confidence. For more information and/or support call 1-800-AnalogD (1-800-262-5643) or visit [www.analog.com/circuit](http://www.analog.com/circuit).

#### Devices Connected/Referenced

ADF7020	ISM Band, FSK/ASK Transceiver
ADuC7060	Low Power, ARM7TDMI, Precision Analog Microcontroller
ADP121	150 mA, Low Quiescent Current, CMOS Linear Regulator

## Low Power, Long Range, ISM Wireless Measuring Node

### CIRCUIT FUNCTION AND BENEFITS

Ideally, a wireless measurement node is low power, has good range, and is easily interfaced to different sensors. Through the combination of three Analog Devices, Inc., parts, an intelligent measurement node with an average current consumption of <math><70 \mu\text{A}</math>, a range of almost 1 km (in free space), and a data rate of one transmission/minute can be achieved, while also maintaining a 16-bit ADC performance (see Figure 1). This makes the circuit suitable for battery power and such applications as automation and remote sensing.

The system consists of a low power temperature measurement node that wakes once a minute, measures temperature, transmits this measurement at 10 kbps to the base node, and then returns to sleep. The base node continuously listens for a package from the measurement node and sends this information to the PC via the UART for display in HyperTerminal.

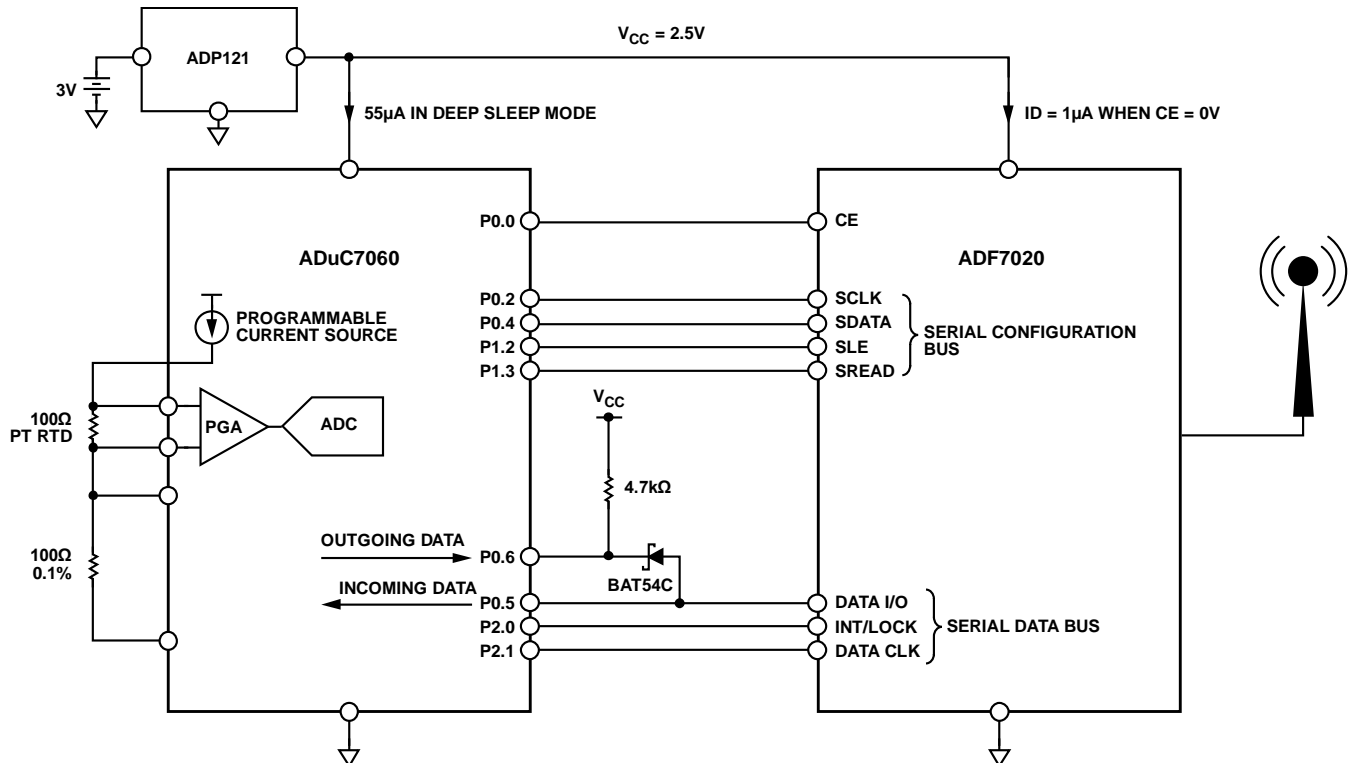

Figure 1. Low Power, Long Range, ISM Wireless Measurement Node (Simplified Schematic: All Connections and Decoupling Not Shown)

#### Rev. A

Circuits from the Lab™ circuits from Analog Devices have been designed and built by Analog Devices engineers. Standard engineering practices have been employed in the design and construction of each circuit, and their function and performance have been tested and verified in a lab environment at room temperature. However, you are solely responsible for testing the circuit and determining its suitability and applicability for your use and application. Accordingly, in no event shall Analog Devices be liable for direct, indirect, special, incidental, consequential or punitive damages due to any cause whatsoever connected to the use of any Circuits from the Lab circuits. (Continued on last page)

The [ADuC7060](#) precision analog microcontroller has a low power ARM7 core as well as a myriad of precision analog functions. The onboard multiplexer, digitally programmable gain amplifier (PGA), voltage reference, programmable current sources, and 24-bit sigma-delta ADC allow almost any temperature and bridge sensors to be directly connected. In this case, a 4-wire Pt100 (100  $\Omega$  platinum RTD) temperature sensor was chosen. Further details on the measuring circuit can be found in the [AN-0970 Application Note](#).

The wireless band chosen for this application is the sub-GHz, license-free ISM (industrial, scientific, medical) band. The [ADF7020](#) transceiver, which supports bands in the 431 MHz to 478 MHz as well as the 862 MHz to 956 MHz frequency ranges, is, therefore, a natural choice. This low power transceiver requires very few external components, is easily connected to the [ADuC7060](#) precision analog microcontroller, and offers excellent performance.

The [ADP121](#) voltage regulator provides the 2.5 V supply from two 1.5 V batteries. The very low quiescent current of this voltage regulator (11  $\mu$ A at no load) is paramount in maximizing battery lifetime.

## CIRCUIT DESCRIPTION

Two buses connect the [ADF7020](#) ISM transceiver with the [ADuC7060](#) precision microcontroller. Both buses are serial and bidirectional. One of these buses configures the transceiver, and it requires four microprocessor ports. The second bus is the data bus, which enables the data transaction between controller and transceiver. This bus requires at least three microprocessor ports. In this particular application, two ports are used instead of one bidirectional port with two interrupts. This simplifies the software but necessitates the use of an extra diode and resistor to separate incoming and outgoing data streams. A parallel combination of two Schottky diodes ensures a logic low, which is less than 200 mV. The BAT54C has two diodes in the same package (connecting Pin 1 and Pin 2 together for a parallel configuration). All digital ports on the [ADuC7060](#) have programmable pull-up resistors; however, an external pull-up resistor is also required. With a data rate of 10 kbps, a 4.7 k $\Omega$  resistor works well.

Three factors determine the overall current drawn by the circuit: the requirement of the individual components in both sleep and active modes), the amount of time the system is active, and the amount of time the transceiver itself is active.

The first factor is addressed by choosing low power components such as the [ADuC7060](#) and the [ADF7020](#). The second factor, minimizing the activity of the system, is achieved by keeping the system inactive as long as possible. It is worth considering the tradeoff between integer versus floating point arithmetic—in many cases, integer is sufficient, has a shorter execution time, and, thus, provides greater savings. The final factor, reducing air time, is achieved in part by using a protocol with minimum overhead, but also to a large extent by using the [ADF7020](#), which has very high receiver sensitivity and good out-of-band rejection, thus maximizing the probability that the data package contains correct data.

## Code Description—General

The system spends the majority of time in deep sleep mode, with a current consumption of 50  $\mu$ A to 60  $\mu$ A (depending on ambient temperature). Timer 2 wakes the system every second. Every 60 seconds, an ADC measurement is executed, linearized, and transmitted. Timer 2 can wake the system from deep sleep; the other three timers cannot. Timer 2 is 16-bit, meaning that it wakes every second when running from a 32 kHz clock (in sleep mode). After the ADC is started, the system goes into pause mode (see the [ADuC7060](#) data sheet for more information). This is a reduced power mode, albeit not as reduced as deep sleep. The ADC wakes the system when finished. A temperature value is calculated from the ADC results and is packaged and transmitted.

Packaging essentially means placing appropriate data in a buffer. In this case, the data consists of a 4-byte floating point temperature value and a 2-byte CRC (cyclic redundancy check). In a more complex system, a header with node address, received signal strength, and other information precedes this data. Before sending this buffer to the [ADF7020](#) transceiver, an 8-byte preamb to help synchronize the receiving node and a 3-byte synchronization word, or sync word, are sent. This is a unique 3-byte number that is checked for a match at the receiver node before a package can be received.

The hardware is very similar on the receiving side; an [ADF7020](#) transceiver is configured to listen for the unique sync word. After the sync word is received, the data package follows. The data is sent to the PC via the UART.

Flowcharts for the main loops of both the measurement node and the base receiving node are displayed in Figure 2.

Source code for this circuit can be found at this address: [www.analog.com/CN0164\\_Source\\_Code](http://www.analog.com/CN0164_Source_Code).

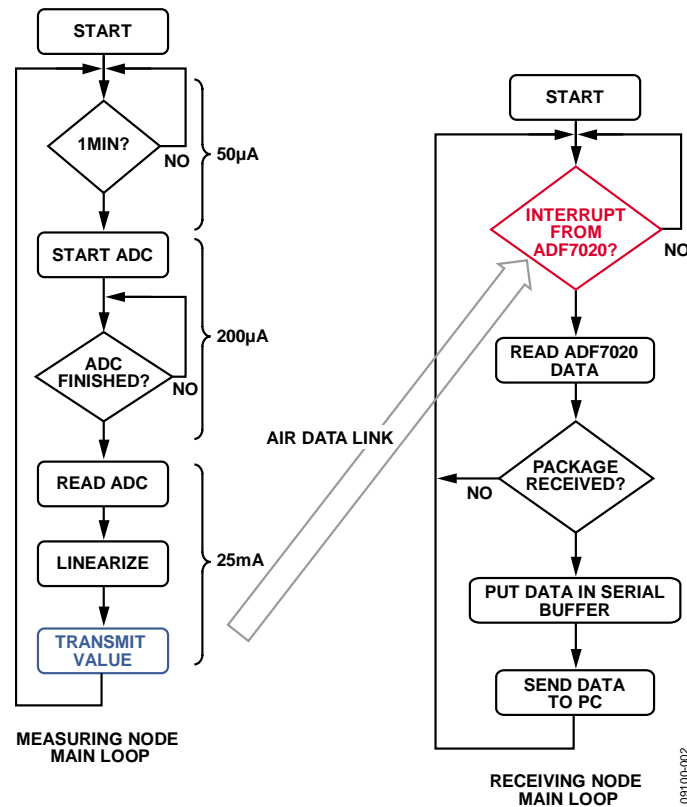

Figure 2. Measuring and Receiving Node Main Loop Flowcharts

### Code Description—ADF7020 Driver

There are many modulation schemes supported by the [ADF7020](#). In this case, the GFSK (gaussian frequency shift keying) is used. This has the benefit of having very good spectral efficiency. In this mode, the [ADF7020](#) generates the data clock both when transmitting and receiving. The rising edge of this clock (DATA CLK) generates an interrupt, which causes the [ADuC7060](#) to place the data on the output port, bit-by-bit as shown in Figure 3. When all the data has been clocked-out, the chip select is deasserted, and the [ADuC7060](#) reenters deep sleep mode.

On the receiving side, the [ADF7020](#) generates an interrupt when a matching sync word is received (Port INT/LOCK goes high for nine clock cycles)

This informs the [ADuC7060](#) processor to prepare for the reception of a package. Each bit that is received from the package causes an interrupt in the [ADuC7060](#). In the interrupt service routine (ISR), the bit stream is read and stored in a buffer. When all the bytes in the package have been received, a flag is set to indicate that a new package has been received. The main loop can now ensure the validity of the package by the checksum. A correct and complete package can be processed. In this case, this information is sent via the UART to the PC for display. The same ISR handles both the sending and receiving of data to/from the ADF7020 transceiver, as shown in Figure 4.

Source code for this circuit can be found at this address: [www.analog.com/CN0164\\_Source\\_Code](http://www.analog.com/CN0164_Source_Code).

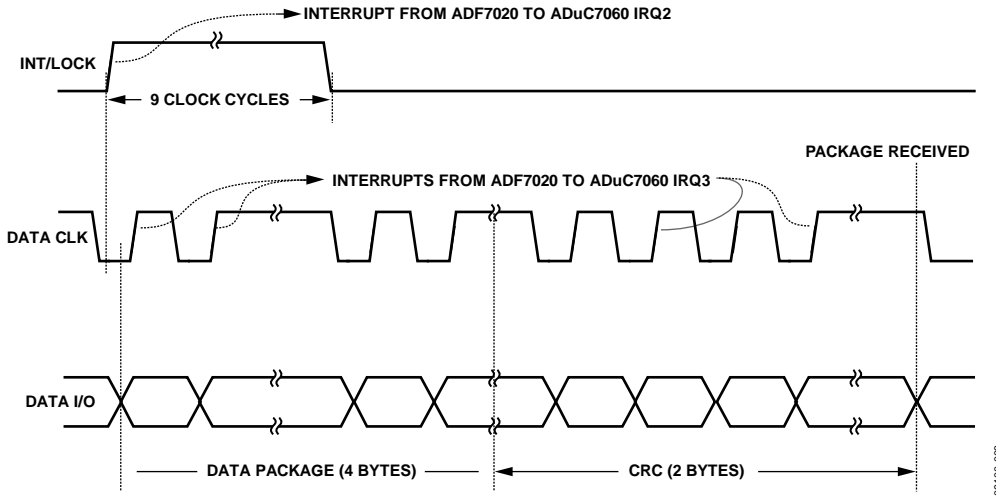

Figure 3. Data I/O Timing

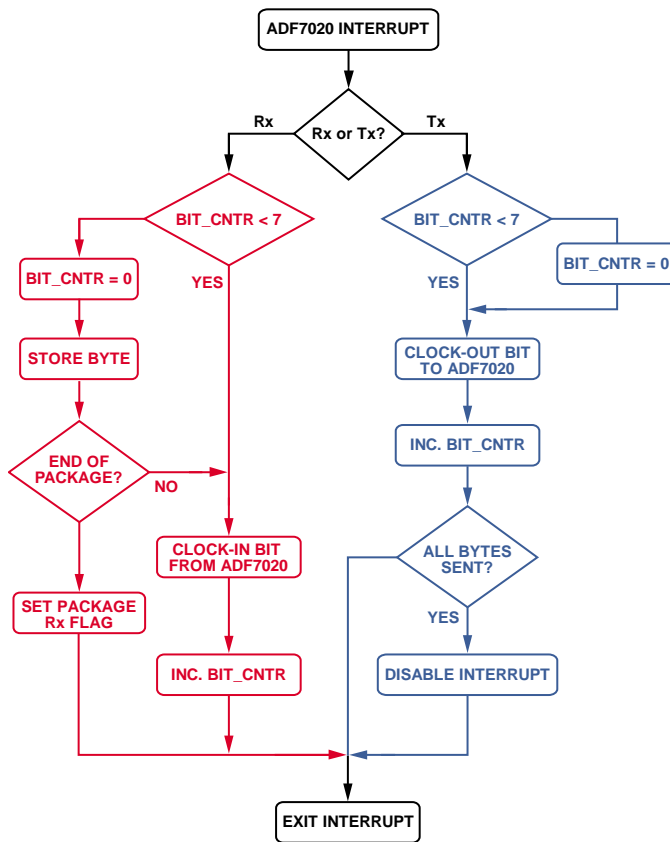

Figure 4. Interrupt Service Routines for Handling Rx and Tx Data

**COMMON VARIATIONS**

Depending on the desired frequency, there are a number of other products that can be used instead of the [ADF7020](#). For example, for the 2.4 GHz frequency band, the [ADF7242](#) is a very good choice.

**LEARN MORE**

[Source code for CN-0164](#)

[Looney, Mike. AN-0970 Application Note. \*RTD Interfacing and Linearization Using an ADuC706x Microcontroller\*, Analog Devices.](#)

**Data Sheets and Evaluation Boards**

[ADF7020 Data Sheet](#)

[ADF7020 Evaluation Board](#)

[ADF7020 Device Drivers](#)

[ADuC7060 Data Sheet](#)

[ADuC7060 Evaluation System](#)

[ADP121 Data Sheet](#)

**REVISION HISTORY**

2/11—Rev. 0 to Rev. A

Change to Circuit Function and Benefits ..... 1

10/10—Revision 0: Initial Version

(Continued from first page) Circuits from the Lab circuits are intended only for use with Analog Devices products and are the intellectual property of Analog Devices or its licensors. While you may use the Circuits from the Lab circuits in the design of your product, no other license is granted by implication or otherwise under any patents or other intellectual property by application or use of the Circuits from the Lab circuits. Information furnished by Analog Devices is believed to be accurate and reliable. However, Circuits from the Lab circuits are supplied "as is" and without warranties of any kind, express, implied, or statutory including, but not limited to, any implied warranty of merchantability, noninfringement or fitness for a particular purpose and no responsibility is assumed by Analog Devices for their use, nor for any infringements of patents or other rights of third parties that may result from their use. Analog Devices reserves the right to change any Circuits from the Lab circuits at any time without notice but is under no obligation to do so.

©2011 Analog Devices, Inc. All rights reserved. Trademarks and registered trademarks are the property of their respective owners.  
CN09100-0-2/11(A)



[www.analog.com](http://www.analog.com)