



M.S.KENNEDY CORP.

10 AMP, 55V, 3 PHASE MOSFET BRUSHLESS MOTOR CONTROLLER

4460

4707 Dey Road Liverpool, N.Y. 13088

(315) 701-6751

FEATURES:

- 55 Volt Motor Supply Voltage
- 10 Amp Output Switch Capability
- 100% Duty Cycle High Side Conduction Capable
- Shoot-Through/Cross Conduction Protection
- Hall Sensing and Commutation Circuitry on Board
- Internal ± 15 Volt Regulators
- "Real" Four Quadrant Torque Control Capability
- Good Accuracy Around the Null Torque Point
- Non-Hermetic Isolated Package for High Voltage Isolation

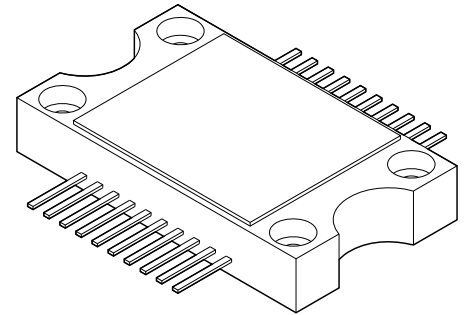

DESCRIPTION:

The MSK 4460 is a complete 3 Phase MOSFET Bridge Brushless Motor Control System in an electrically isolated low cost package. The hybrid is capable of 10 amps of output current and 55 volts of DC bus voltage. It has the normal features for protecting the bridge. Included is all the bridge drive circuitry, hall sensing circuitry, commutation circuitry and all the current sensing and analog circuitry necessary for closed loop current mode (torque) control. When PWM'ing, the transistors are modulated in locked anti-phase mode for the tightest control and the most bandwidth. Provisions for applying different compensation schemes are included. The MSK 4460 has good thermal conductivity of the MOSFET's due to isolated substrate/package design that allows direct heat sinking of the hybrid without insulators.

EQUIVALENT SCHEMATIC

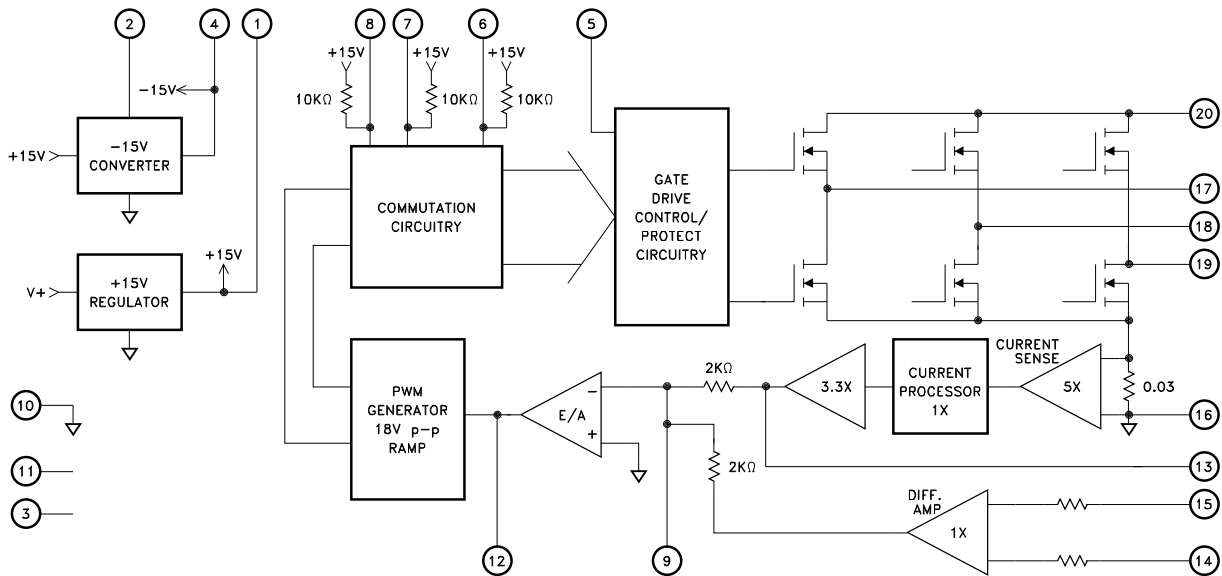

TYPICAL APPLICATIONS

- 3 Phase Brushless DC Motor Control
 - Servo Control
 - Fin Actuator Control
- Gimbal Control
 - AZ-EL Control

PIN-OUT INFORMATION

1 +15V	20 V+
2 L1	19 MOTOR DRIVE C
3 NC	18 MOTOR DRIVE B
4 -15V	17 MOTOR DRIVE A
5 DIS	16 V+ RTN
6 HALL C	15 +CURRENT COMMAND
7 HALL B	14 -CURRENT COMMAND
8 HALL A	13 CURRENT MONITOR
9 E/A-	12 E/A OUT
10 SIG GND	11 NC

ABSOLUTE MAXIMUM RATINGS

⑤

V+	High Voltage Supply	55V
I _Q	V+ Quiescent Current	0.16A
V _{IN}	Current Command Input	±13.5V
+15V	Output Current	20mA
-15V	Output Current	20mA
I _{OUT}	Continuous Output Current	10A
I _{PK}	Peak Output Current	16A

θ _{JC}	Thermal Resistance (Regulator)	11.1°C/W
θ _{JC}	Thermal Resistance (Output Switches)	9.5°C/W
T _{ST}	Storage Temperature Range	-55°C to +125°C
T _{LD}	Lead Temperature Range (10 Seconds)	+300°C
T _C	Case Operating Temperature MSK4460	-40°C to +85°C
T _J	Junction Temperature	+150°C

ELECTRICAL SPECIFICATIONS

Parameter	Test Conditions	MSK 4460			Units
		Min.	Typ.	Max.	
PWM					
Clock Frequency		14	16	19	KHz
REGULATORS					
+15 V _{OUT}	20mA Load ③	14.25	-	15.75	VOLTS
-15 V _{OUT}	20mA Load ③	-15.75	-	-14.25	VOLTS
-15 V _{OUT} Ripple	20mA Load	-	-	250	mV
HALL INPUTS					
V _{IL} ①		-	-	0.8	VOLTS
V _{IH} ①		3.0	-	-	VOLTS
ANALOG SECTION					
Current Command Input Range ①		-13.5	-	+13.5	VOLTS
Current Command Input Current ①		-	-	1.5	mA
Transconductance ④		1.8	2	2.2	A/V
Offset Current	Current Command = 0 Volts	-50	0	50	mA
Current Monitor ④	@ ±1 Amp Output	0.42	0.5	0.58	V/A
Current Monitor Voltage Swing ①	5mA Load	-12	-	+12	VOLTS
ERROR AMP					
E/A OUTPUT Swing ①	5mA Load	-12	-	+12	VOLTS
Slew Rate ①		-	3	-	V/μSec
Unity Gain Bandwidth ①		-	1.8	-	MHz
Large Signal Voltage Gain ①		-	400	-	V/mV
OUTPUT SECTION					
Voltage Drop Across Bridge (1 Upper & 1 Lower) ①	10 AMPS	-	0.8	-	VOLTS
Voltage Drop Across Bridge (1 Upper & 1 Lower) ①	10 AMPS @ 150°C Junction	-	1.6	1.92	VOLTS
Leakage Current ①	All switches off, V+ = 44V, 150°C Junction	-	-	750	μA
Diode VSD ①		-	-	1.6	VOLTS
t _{rr} ①		-	86	-	nSec
Dead Time ①		-	2	-	μSec
DISABLE					
V _{IL} ①		-	-	0.8	VOLTS
V _{IN} ①		3.0	-	-	VOLTS
Input Current ①		-	-	3.1	mA

NOTES:

- ① Guaranteed by design but not tested. Typical parameters are representative of actual device performance but are for reference only.
- ② V+ = 28V, T_{CASE} = 25°C unless otherwise specified.
- ③ Maximum power dissipation must be limited according to voltage regulator power dissipation.
- ④ Measurements do not include offset current at 0V current command.
- ⑤ Continuous operation at or above absolute maximum ratings may adversely effect the device performance and/or life cycle.

APPLICATION NOTES

MSK 4460 PIN DESCRIPTIONS

V+ - is the power connection from the hybrid to the bus. The external wiring to the pin should be sized according to the RMS current required by the motor. The pin should be bypassed by a high quality monolithic ceramic capacitor for high frequencies and enough bulk capacitance for keeping the V+ supply from drooping. 78 μ F of ceramic capacitance and 1700 μ F of bulk capacitance was used in the test circuit. The voltage range on the pin is from 16 volts up to 55 volts.

MOTOR DRIVE A,B,C - are the connections to the motor phase windings from the bridge output. The wiring to these pins should be sized according to the required current by the motor. There are no short circuit provisions for these outputs. Shorts to V+ or V+ RTN from these pins must be avoided or the bridge will be destroyed.

V+ RTN - is the power return connection from the module to the bus. All ground returns connect to this point from internal to the module in a star fashion. All external ground connections to this point should also be made in a similar fashion. The V+ capacitors should be returned to this pin as close as possible. Wire sizing to this pin connection should be made according to the required current.

SIG GND - is a ground pin that connects to the ground plane for all low powered circuitry inside the hybrid.

+15 V - is a regulated +15 volt output available for external uses. Up to 20 mA is available at this pin. A 10 microfarad capacitor should be connected as close to this pin as possible and returned to SIG GND along with a 0.22 microfarad monolithic ceramic capacitor. **CAUTION: See Voltage Regulator Power Dissipation.**

L1 - is a pin for connecting an external inductor to the DC - DC converter for generating -15 volts. A 47 μ H switching inductor capable of running at 250 KHz and about 1 amp of DC current shall be used. Connect the inductor between L1 and SIG GND.

-15 V - is a regulated -15 volt output available for external uses. Up to 20 mA is available at this pin. A 10 microfarad capacitor should be connected as close to this pin as possible and returned to SIG GND along with a 0.22 microfarad monolithic ceramic capacitor. **CAUTION: See Voltage Regulator Power Dissipation**

CURRENT COMMAND (+,-) - are differential inputs for controlling the module in current mode. Scaled at ± 2 amps per volt of input command, the bipolar input allows both forward and reverse current control capability regardless of motor commutation direction. The maximum operational command voltage should be ± 5 volts for ± 10 amps of motor current.

CURRENT MONITOR - is a pin providing a current viewing signal for external monitoring purposes. This is scaled at ± 2 amps of motor current per volt output, up to a maximum of ± 5 volts, or ± 10 amps. As ± 10 amps is exceeded, the peaks of the waveform may become clipped as the rails of the amplifiers are reached. This voltage is typically ± 8 volts, equating to ± 16 amps of current peaks.

E/A OUT - is the current loop error amp output connection. It is brought out for allowing various loop compensation circuits to be connected between this and E/A-.

E/A- - is the current loop error amp inverting input connection. It is brought out for allowing various loop compensation circuits to be connected between this and E/A OUT.

HALL A, B & C - are the hall input pins from the hall devices in the motor. These pins are internally pulled up to 15 volts. The halls reflect a 120/240 degree commutation scheme.

DISABLE - is a pin for externally disabling the output bridge. A TTL logic low will enable the bridge, and a TTL logic high will disable it. It is internally pulled low by a 5K ohm resistor.

VOLTAGE REGULATOR POWER DISSIPATION - To figure voltage regulator power dissipation and junction temperature, use the following as an example:

Given:

V+ = 28V, MSK 4460 +15V IQ = 80mA, -15V IQ = 40mA.

External Loads: +15V = 20 mA, -15V = 20 mA

-15V Converter Efficiency = 50%

P_{DISS} due to +15V IQ, 80 mA x 13V = 1.04 W

P_{DISS} due to -15V IQ, (40 mA / 0.5) x 13V = 1.04 W

P_{DISS} due to +15V Ext load, 20 mA x 13V = 260 mW

P_{DISS} due to -15V Ext load, (20 mA / 0.5) x 13V = 620mW

P_{DISS} Total = 1.04W + 1.04 W + 260 mW + 520mW = 2.86W

3.12W x 11.1°C/W = 32°C RISE above case temperature

Maximum Case Temperature = 150°C - 32°C = 118°C

COMMUTATION TRUTH TABLE

HALL SENSOR PHASING			ICOMMAND = POS.			ICOMMAND = NEG.		
120°			AØ	BØ	CØ	AØ	BØ	CØ
HALL A	HALL B	HALL C	AØ	BØ	CØ	AØ	BØ	CØ
1	0	0	H	-	L	L	-	H
1	1	0	-	H	L	-	L	H
0	1	0	L	H	-	H	L	-
0	1	1	L	-	H	H	-	L
0	0	1	-	L	H	-	H	L
1	0	1	H	L	-	L	H	-
1	1	1	-	-	-	-	-	-
0	0	0	-	-	-	-	-	-
X	X	X	L	L	L	L	L	L

1 = High Level H = SOURCE
 0 = Low Level L = SINK
 X = Don't Care - = OPEN

NOTE: Because of the true 4 quadrant method of output switching, the output switches will PWM between the ICOMMAND POSITIVE and ICOMMAND NEGATIVE states, with the average percentage based on ICOMMAND being a positive voltage and a negative voltage. With a zero voltage ICOMMAND, the output switches will modulate with exactly a 50% duty cycle between the ICOMMAND POSITIVE and ICOMMAND NEGATIVE states.

APPLICATION NOTES CONTINUED

BUS VOLTAGE FILTER CAPACITORS

The size and placement of the capacitors for the DC bus has a direct bearing on the amount of noise filtered and also on the size and duration of the voltage spikes seen by the bridge. What is being created is a series RLC tuned circuit with a resonant frequency that is seen as a damped ringing every time one of the transistors switches. For the resistance, wire resistance, power supply impedance and capacitor ESR all add up for the equivalent lumped resistance in the circuit. The inductance can be figured at about 30 nH per inch from the power supply. Any voltage spikes are on top of the bus voltage and the back EMF from the motor. All this must be taken into account when designing and laying out the system. If everything has been minimized, there is another solution. A second capacitance between 5 and 10 times the first capacitor and it should either have some ESR or a resistor can be added in series with the second capacitor to help damp the voltage spikes.

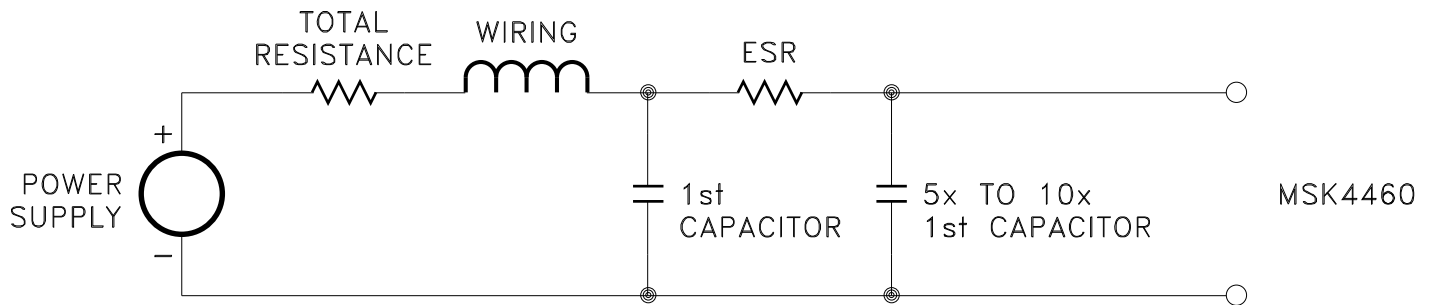

Be careful of the ripple current in all the capacitors. Excessive ripple current, beyond what the capacitors can handle, will destroy the capacitors.

REGULATED VOLTAGE FILTER CAPACITORS

It is recommended that about 10 μF of capacitance (tantalum electrolytic) for bypassing the + and -15V regulated outputs be placed as close to the module pins as practical. Adding ceramic bypass capacitors of about 0.1 μF to 1 μF will aid in suppressing noise transients.

GENERAL LAYOUT

Good PC layout techniques are a must. Ground plane for the analog circuitry must be used and should be tied back to the SIG GND. Ground plane for the power circuitry should be tied back to the V+ RTN pin, pin 16. Pin 16 should be connected to pin 10 external to the hybrid by a single thick trace. This will connect the two ground planes together.

LOW POWER STARTUP

When starting up a system utilizing the MSK 4460 for the first time, there are a few things to keep in mind. First, because of the small size of the module, short circuiting the output phases either to ground or the DC bus will destroy the bridge. The current limiting and control only works for current actually flowing through the bridge. The current sense resistor has to see the current in order for the electronics to control it. If possible, for startup use a lower voltage and lower current power supply to test out connections and the low current stability. With a limited current supply, even if the controller locks up, the dissipation will be limited. By observing the E/A OUT pin which is the error amp output, much can be found out about the health and stability of the system. An even waveform with some rounded triangle wave should be observed. As current goes up, the DC component of the waveform should move up or down. At full current (with a regular supply) the waveform should not exceed +8 volts positive peak, or -8 volts negative peak. Some audible noise will be heard which will be the commutation frequency. If the motor squeals, there is instability and power should be removed immediately unless power dissipation isn't excessive due to limited supply current. For compensation calculations, refer to the block diagram for all information to determine the amplifier gain for loop gain calculations.

MSK4460 TEST CIRCUIT

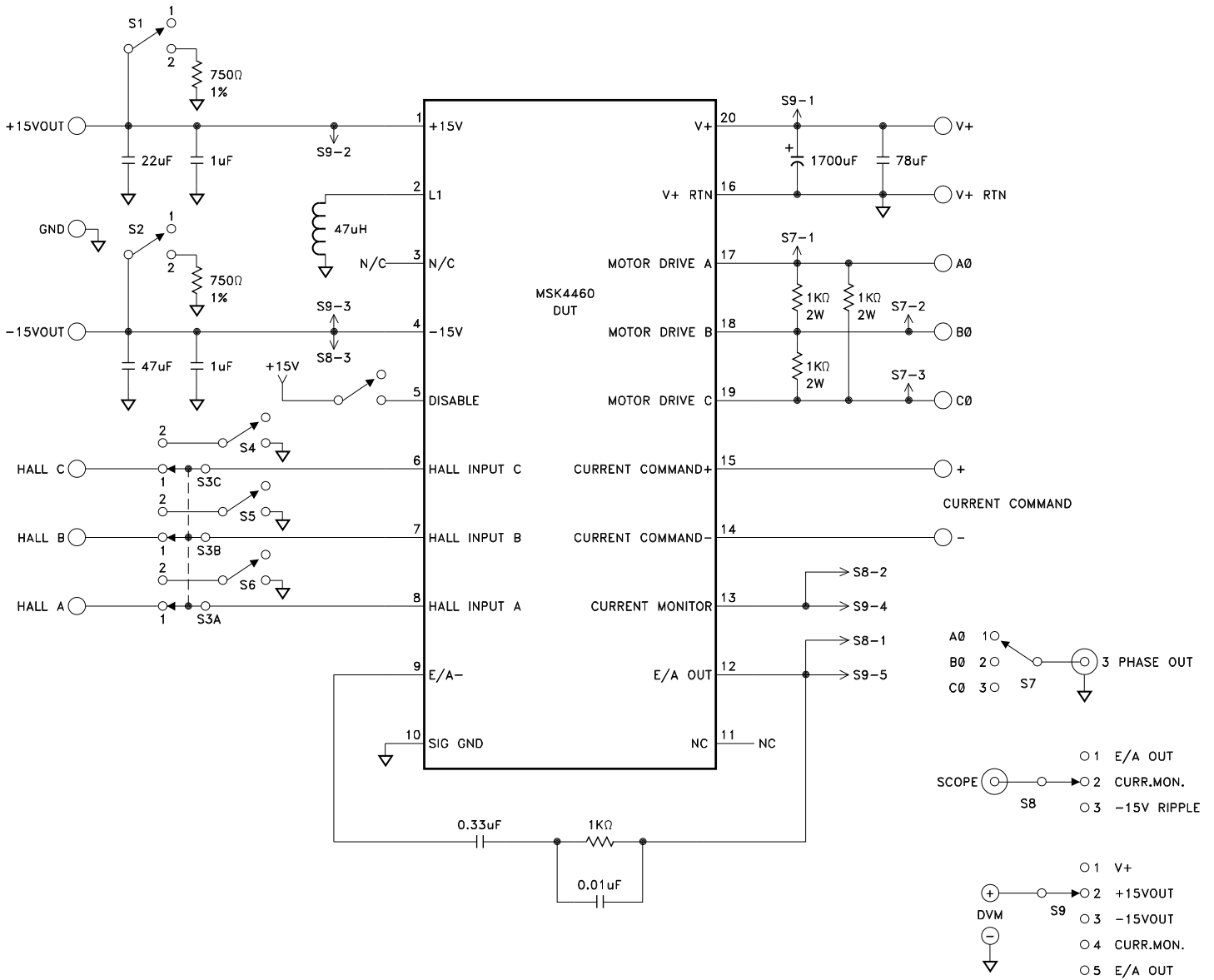

MECHANICAL SPECIFICATIONS

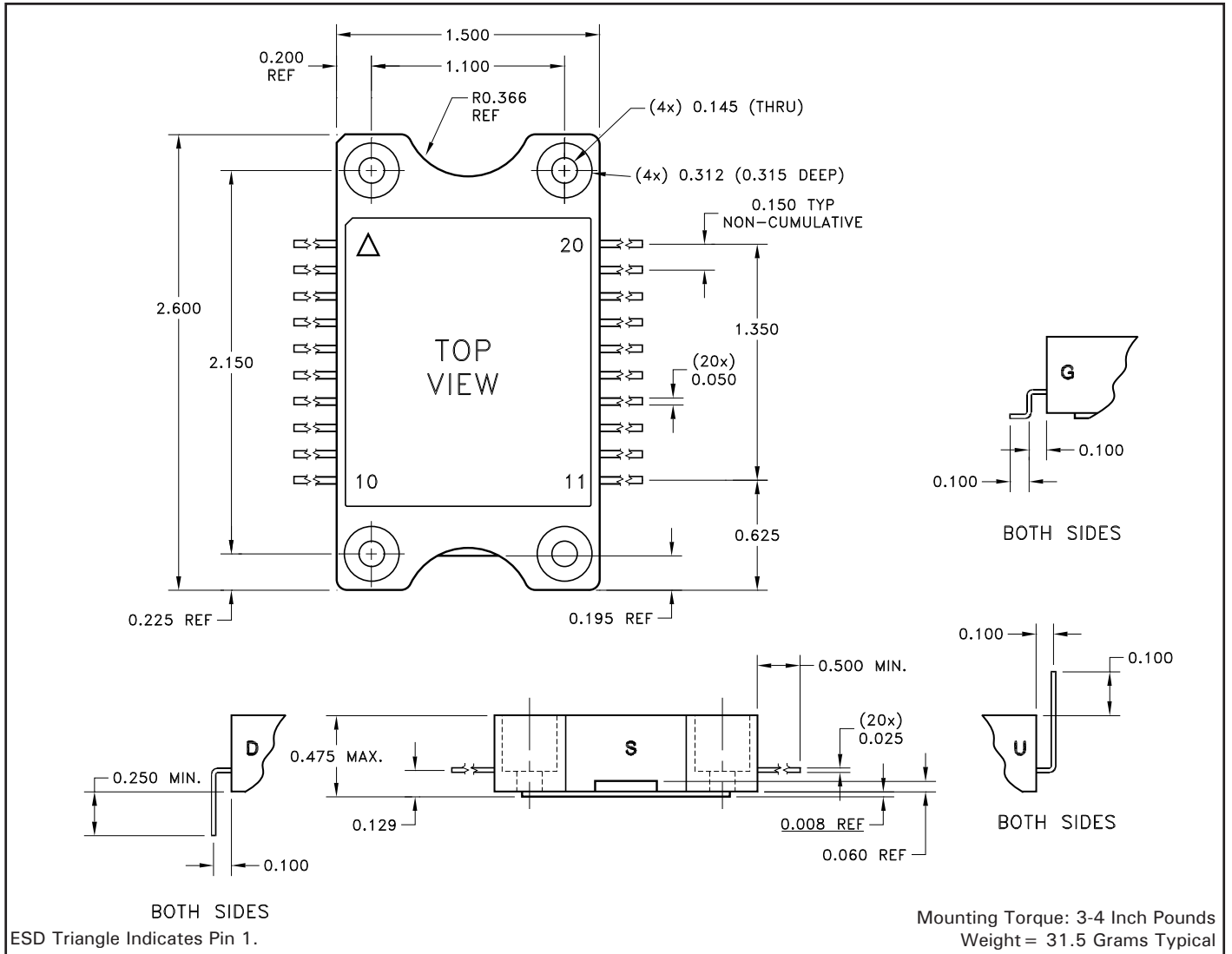

NOTE: ALL DIMENSIONS ARE $\pm .010$ INCHES UNLESS OTHERWISE LABELED.

CAUTION: THIS IS A NON-HERMETIC DEVICE. DO NOT EXPOSE PLASTIC HOUSING TO LIQUID

ORDERING INFORMATION

Part Number	Screening Level	Lead Configuration
MSK4460S	Industrial	Straight
MSK4460D	Industrial	Down
MSK4460U	Industrial	Up
MSK4460G	Industrial	Gullwing

M.S. Kennedy Corp.
4707 Dey Road Liverpool, New York 13088
Phone (315) 701-6751
FAX (315) 701-6752
www.mskennedy.com

The information contained herein is believed to be accurate at the time of printing. MSK reserves the right to make changes to its products or specifications without notice, however, and assumes no liability for the use of its products. Please visit our website for the most recent revision of this datasheet.