

MC68HC05C9A/D  
REV 5



**MC68HC05C9A**  
**MC68HCL05C9A**  
**MC68HSC05C9A**

**Advance Information**

HCMOS

Microcontroller Unit

 **Digital DNA**<sup>™</sup>  
from Motorola



# MC68HC05C9A

# MC68HCL05C9A

# MC68HSC05C9A

## Advance Information

---

---

*Motorola reserves the right to make changes without further notice to any products herein. Motorola makes no warranty, representation or guarantee regarding the suitability of its products for any particular purpose, nor does Motorola assume any liability arising out of the application or use of any product or circuit, and specifically disclaims any and all liability, including without limitation consequential or incidental damages. "Typical" parameters which may be provided in Motorola data sheets and/or specifications can and do vary in different applications and actual performance may vary over time. All operating parameters, including "Typicals" must be validated for each customer application by customer's technical experts. Motorola does not convey any license under its patent rights nor the rights of others. Motorola products are not designed, intended, or authorized for use as components in systems intended for surgical implant into the body, or other applications intended to support or sustain life, or for any other application in which the failure of the Motorola product could create a situation where personal injury or death may occur. Should Buyer purchase or use Motorola products for any such unintended or unauthorized application, Buyer shall indemnify and hold Motorola and its officers, employees, subsidiaries, affiliates, and distributors harmless against all claims, costs, damages, and expenses, and reasonable attorney fees arising out of, directly or indirectly, any claim of personal injury or death associated with such unintended or unauthorized use, even if such claim alleges that Motorola was negligent regarding the design or manufacture of the part. Motorola, Inc. is an Equal Opportunity/Affirmative Action Employer.*

Motorola and  are registered trademarks of Motorola, Inc.  
DigitalDNA is a trademark of Motorola, Inc.

© Motorola, Inc., 1997, 2000



## List of Sections

Section 1. General Description . . . . .	19
Section 2. Memory . . . . .	29
Section 3. Central Processor Unit (CPU) . . . . .	37
Section 4. Interrupts . . . . .	41
Section 5. Resets . . . . .	47
Section 6. Low-Power Modes. . . . .	55
Section 7. Input/Output Ports . . . . .	57
Section 8. Capture/Compare Timer . . . . .	61
Section 9. Serial Communications Interface (SCI). . . . .	73
Section 10. Serial Peripheral Interface (SPI). . . . .	91
Section 11. Instruction Set. . . . .	103
Section 12. Electrical Specifications. . . . .	121
Section 13. Mechanical Specifications . . . . .	137
Section 14. Ordering Information . . . . .	141
Appendix A. MC68HCL05C9A . . . . .	143
Appendix B. MC68HSC05C9A . . . . .	147
Appendix C. Self-Check Mode . . . . .	155
Appendix D. M68HC05Cx Family Feature Comparisons . . . . .	159

# List of Sections

## Table of Contents

### Section 1. General Description

1.1	Contents . . . . .	19
1.2	Introduction . . . . .	19
1.3	Features . . . . .	20
1.4	Mask Options . . . . .	20
1.5	Software-Programmable Options . . . . .	22
1.6	Functional Pin Descriptions . . . . .	23
1.6.1	$V_{DD}$ and $V_{SS}$ . . . . .	26
1.6.2	$\overline{IRQ}$ . . . . .	26
1.6.3	OSC1 and OSC2 . . . . .	27
1.6.4	$\overline{RESET}$ . . . . .	27
1.6.5	TCAP . . . . .	27
1.6.6	TCMP . . . . .	27
1.6.7	PA0–PA7 . . . . .	27
1.6.8	PB0–PB7 . . . . .	28
1.6.9	PC0–PC7 . . . . .	28
1.6.10	PD0–PD5 and PD7 . . . . .	28

### Section 2. Memory

2.1	Contents . . . . .	29
2.2	Introduction . . . . .	29
2.3	RAM . . . . .	31
2.4	ROM . . . . .	31
2.5	ROM Security . . . . .	31
2.6	I/O Registers . . . . .	31

## Section 3. Central Processor Unit (CPU)

3.1	Contents . . . . .	37
3.2	Introduction . . . . .	37
3.3	CPU Registers . . . . .	38
3.3.1	Accumulator (A) . . . . .	39
3.3.2	Index Register (X) . . . . .	39
3.3.3	Program Counter (PC) . . . . .	39
3.3.4	Stack Pointer (SP) . . . . .	39
3.3.5	Condition Code Register (CCR) . . . . .	40

## Section 4. Interrupts

4.1	Contents . . . . .	41
4.2	Introduction . . . . .	41
4.3	Non-Maskable Software Interrupt (SWI) . . . . .	42
4.4	External Interrupt ( $\overline{\text{IRQ}}$ or Port B) . . . . .	42
4.5	Timer Interrupt . . . . .	44
4.6	SCI Interrupt . . . . .	44
4.7	SPI Interrupt . . . . .	44

## Section 5. Resets

5.1	Contents . . . . .	47
5.2	Introduction . . . . .	47
5.3	Power-On Reset (POR) . . . . .	48
5.4	$\overline{\text{RESET}}$ Pin . . . . .	49
5.5	Computer Operating Properly (COP) Reset . . . . .	50
5.5.1	COP Reset Register . . . . .	51
5.5.2	COP Control Register . . . . .	52
5.6	COP During Wait Mode . . . . .	54
5.7	COP During Stop Mode . . . . .	54
5.8	Clock Monitor Reset . . . . .	54



## Section 6. Low-Power Modes

6.1	Contents . . . . .	55
6.2	Introduction . . . . .	55
6.3	Stop Mode . . . . .	55
6.4	Wait Mode . . . . .	56

## Section 7. Input/Output Ports

7.1	Contents . . . . .	57
7.2	Introduction . . . . .	57
7.3	Port A . . . . .	57
7.4	Port B . . . . .	58
7.5	Port C . . . . .	59
7.6	Port D . . . . .	59

## Section 8. Capture/Compare Timer

8.1	Content . . . . .	61
8.2	Introduction . . . . .	61
8.3	Timer Operation . . . . .	62
8.3.1	Input Capture . . . . .	63
8.3.2	Output Compare . . . . .	63
8.4	Timer I/O Registers . . . . .	64
8.4.1	Timer Control Register . . . . .	64
8.4.2	Timer Status Register . . . . .	66
8.4.3	Timer Registers . . . . .	67
8.4.4	Alternate Timer Registers . . . . .	68
8.4.5	Input Capture Registers . . . . .	69
8.4.6	Output Compare Registers . . . . .	70
8.5	Timer During Wait Mode . . . . .	71
8.6	Timer During Stop Mode . . . . .	71

## Section 9. Serial Communications Interface (SCI)

9.1	Content . . . . .	73
9.2	Introduction . . . . .	74

## Table of Contents

9.3	Features	74
9.4	SCI Receiver Features	76
9.5	SCI Transmitter Features	76
9.6	Functional Description	76
9.7	Data Format	78
9.8	Receiver Wakeup Operation	78
9.8.1	Idle Line Wakeup	79
9.8.2	Address Mark Wakeup	79
9.9	Receive Data In (RDI)	80
9.10	Start Bit Detection	81
9.11	Transmit Data Out (TDO)	82
9.12	SCI I/O Registers	82
9.12.1	SCI Data Register	83
9.12.2	SCI Control Register 1	83
9.12.3	SCI Control Register 2	84
9.12.4	SCI Status Register	87
9.12.5	Baud Rate Register	89

## Section 10. Serial Peripheral Interface (SPI)

10.1	Content	91
10.2	Introduction	91
10.3	Features	92
10.4	SPI Signal Description	92
10.4.1	Master In/Slave Out (MISO)	93
10.4.2	Master Out/Slave In (MOSI)	93
10.4.3	Serial Clock ( $\overline{SCK}$ )	94
10.4.4	Slave Select ( $\overline{SS}$ )	94
10.5	Functional Description	95
10.6	SPI Registers	97
10.6.1	Serial Peripheral Control Register	97
10.6.2	Serial Peripheral Status Register	99
10.6.3	Serial Peripheral Data I/O Register	101

## Section 11. Instruction Set

11.1	Contents . . . . .	103
11.2	Introduction . . . . .	103
11.3	Addressing Modes . . . . .	104
11.3.1	Inherent . . . . .	104
11.3.2	Immediate . . . . .	104
11.3.3	Direct . . . . .	105
11.3.4	Extended . . . . .	105
11.3.5	Indexed, No Offset . . . . .	105
11.3.6	Indexed, 8-Bit Offset . . . . .	105
11.3.7	Indexed, 16-Bit Offset . . . . .	106
11.3.8	Relative . . . . .	106
11.4	Instruction Types . . . . .	107
11.4.1	Register/Memory Instructions . . . . .	107
11.4.2	Read-Modify-Write Instructions . . . . .	108
11.4.3	Jump/Branch Instructions . . . . .	109
11.4.4	Bit Manipulation Instructions . . . . .	111
11.4.5	Control Instructions . . . . .	111
11.5	Instruction Set Summary . . . . .	112
11.6	Opcode Map . . . . .	118

## Section 12. Electrical Specifications

12.1	Contents . . . . .	121
12.2	Maximum Ratings . . . . .	122
12.3	Operating Temperature . . . . .	123
12.4	Thermal Characteristics . . . . .	123
12.5	Power Considerations . . . . .	124
12.6	5.0-Volt DC Electrical Characteristics . . . . .	125
12.7	3.3-Volt DC Electrical Characteristics . . . . .	126
12.8	5.0-Volt Control Timing . . . . .	128
12.9	3.3-Volt Control Timing . . . . .	129
12.10	5.0-Volt Serial Peripheral Interface Timing . . . . .	132
12.11	3.3-Volt Serial Peripheral Interface Timing . . . . .	133

## Section 13. Mechanical Specifications

13.1	Contents . . . . .	137
13.2	Introduction . . . . .	137
13.3	40-Pin Plastic Dual In-Line (DIP) Package (Case 711-03) . . . . .	138
13.4	42-Pin Plastic Shrink Dual In-Line (SDIP) Package (Case 858-01) . . . . .	138
13.5	44-Lead Plastic-Leaded Chip Carrier (PLCC) (Case 777-02) . . . . .	139
13.6	44-Lead Quad Flat Pack (QFP) (Case 824A-01) . . . . .	140

## Section 14. Ordering Information

14.1	Contents . . . . .	141
14.2	Introduction . . . . .	141
14.3	MC Order Numbers . . . . .	141

## Appendix A. MC68HCL05C9A

A.1	Contents . . . . .	143
A.2	Introduction . . . . .	143
A.3	Operating Temperature . . . . .	143
A.4	DC Electrical Characteristics . . . . .	144
A.4.1	1.8–2.4-Volt Low-Power Output Voltage . . . . .	144
A.4.2	1.8–2.4-Volt Input Pullup Current . . . . .	144
A.4.3	2.5–3.6-Volt Low-Power Output Voltage . . . . .	145
A.4.4	2.6–3.6-Volt Input Pullup Current . . . . .	145
A.4.5	Low-Power Supply Current . . . . .	146

## Appendix B. MC68HSC05C9A

B.1	Contents . . . . .	147
B.2	Introduction . . . . .	147
B.3	Operating Temperature . . . . .	148

B.4	DC Electrical Characteristics . . . . .	149
B.4.1	High-Speed Supply Current . . . . .	149
B.4.2	Input Pullup Current . . . . .	149
B.5	Control Timing . . . . .	150
B.5.1	4.5–5.5-Volt High-Speed Control Timing . . . . .	150
B.5.2	2.4–3.6-Volt High-Speed Control Timing . . . . .	151
B.5.3	4.5–5.5-Volt High-Speed Control Timing . . . . .	152
B.5.4	2.4–3.6-Volt High-Speed SPI Timing . . . . .	153

### **Appendix C. Self-Check Mode**

C.1	Contents . . . . .	155
C.2	Introduction . . . . .	155
C.3	Self-Check Mode . . . . .	156
C.3.1	Self-Check Tests . . . . .	156
C.3.2	Self-Check Results . . . . .	158

### **Appendix D. M68HC05Cx Family Feature Comparisons**

# Table of Contents

## List of Figures

Figure	Title	Page
1-1	Block Diagram . . . . .	21
1-2	Option Register. . . . .	22
1-3	40-Pin PDIP Pin Assignments . . . . .	23
1-4	42-Pin SDIP Pin Assignments . . . . .	24
1-5	44-Lead PLCC Pin Assignments . . . . .	25
1-6	44-Pin QFP Pin Assignments . . . . .	26
2-1	Memory Map. . . . .	30
2-2	I/O Register Summary . . . . .	32
2-3	Input/Output Registers . . . . .	33
3-1	Programming Model . . . . .	38
3-2	Interrupt Stacking Order . . . . .	38
4-1	Interrupt Flowchart . . . . .	45
5-1	Reset Sources . . . . .	48
5-2	Power-On Reset and $\overline{\text{RESET}}$ . . . . .	49
5-3	COP Block Diagram . . . . .	50
5-4	COP Reset Register (COPRST). . . . .	51
5-5	COP Control Register (COPCR). . . . .	52
6-1	Stop Recovery Timing Diagram . . . . .	56
7-1	Port A I/O Circuit. . . . .	58
7-2	Port B I/O Logic . . . . .	60
8-1	Capture/Compare Timer Block Diagram. . . . .	62
8-2	Timer Control Register (TCR). . . . .	64
8-3	Timer Status Register (TSR) . . . . .	66
8-4	Timer Registers (TRH and TRL). . . . .	67
8-5	Alternate Timer Registers (ATRH and ATRL). . . . .	68
8-6	Input Capture Registers (ICRH and ICRL) . . . . .	69
8-7	Output Compare Registers (OCRH and OCRL). . . . .	70

## List of Figures

Figure	Title	Page
9-1	Serial Communications Interface Block Diagram . . . . .	75
9-2	Rate Generator Division . . . . .	77
9-3	Data Format . . . . .	78
9-4	SCI Examples of Start Bit Sampling Techniques . . . . .	80
9-5	SCI Sampling Technique Used on All Bits . . . . .	80
9-6	SCI Artificial Start Following a Frame Error . . . . .	81
9-7	SCI Start Bit Following a Break . . . . .	82
9-8	SCI Data Register (SCDR) . . . . .	83
9-9	SCI Control Register 1 (SCCR1) . . . . .	83
9-10	SCI Control Register 2 (SCCR2) . . . . .	85
9-11	SCI Status Register (SCSR) . . . . .	87
9-12	Baud Rate Register (BAUD) . . . . .	89
10-1	Data Clock Timing Diagram . . . . .	93
10-2	Serial Peripheral Interface Block Diagram . . . . .	95
10-3	Serial Peripheral Interface Master-Slave Interconnection . . . . .	96
10-4	SPI Control Register (SPCR) . . . . .	97
10-5	SPI Status Register . . . . .	99
10-6	SPI Data Register (SPDR) . . . . .	101
12-1	Test Load . . . . .	123
12-2	Maximum Supply Current versus Internal Clock Frequency, $V_{DD} = 5.5\text{ V}$ . . . . .	127
12-3	Maximum Supply Current versus Internal Clock Frequency, $V_{DD} = 3.6\text{ V}$ . . . . .	127
12-4	TCAP Timing Relationships . . . . .	129
12-5	External Interrupt Timing . . . . .	130
12-6	Stop Recovery Timing Diagram . . . . .	130
12-7	Power-On Reset Timing Diagram . . . . .	131
12-8	External Reset Timing . . . . .	131
12-9	SPI Master Timing Diagram . . . . .	134
12-10	SPI Slave Timing Diagram . . . . .	135
13-1	40-Pin Plastic DIP Package (Case 711-03) . . . . .	138
13-2	42-Pin Plastic SDIP Package (Case 858-01) . . . . .	138
13-3	44-Lead PLCC (Case 777-02) . . . . .	139
13-4	44-Lead QFP (Case 824A-01) . . . . .	140
C-1	Self-Check Circuit Schematic . . . . .	157



## **List of Tables**

<b>Table</b>	<b>Title</b>	<b>Page</b>
4-1	Vector Addresses for Interrupts and Resets . . . . .	43
5-1	COP Timeout Period . . . . .	53
9-1	Baud Rate Generator Clock Prescaling . . . . .	89
9-2	Baud Rate Selection . . . . .	90
10-1	SPI Clock Rate Selection . . . . .	99
11-1	Register/Memory Instructions . . . . .	107
11-2	Read-Modify-Write Instructions . . . . .	108
11-3	Jump and Branch Instructions . . . . .	110
11-4	Bit Manipulation Instructions . . . . .	111
11-5	Control Instructions . . . . .	111
11-6	Instruction Set Summary . . . . .	112
11-7	Opcode Map . . . . .	119
14-1	MC Order Numbers . . . . .	141
B-1	High-Speed Operating Temperature Range . . . . .	148
C-1	Self-Check Circuit LED Codes . . . . .	158
D-1	M68HC05Cx Feature Comparison . . . . .	160

# List of Tables

## Section 1. General Description

### 1.1 Contents

1.2	Introduction . . . . .	19
1.3	Features . . . . .	20
1.4	Mask Options . . . . .	20
1.5	Software-Programmable Options . . . . .	22
1.6	Functional Pin Descriptions . . . . .	23
1.6.1	$V_{DD}$ and $V_{SS}$ . . . . .	26
1.6.2	IRQ . . . . .	26
1.6.3	OSC1 and OSC2 . . . . .	27
1.6.4	$\overline{RESET}$ . . . . .	27
1.6.5	TCAP . . . . .	27
1.6.6	TCMP . . . . .	27
1.6.7	PA0–PA7 . . . . .	27
1.6.8	PB0–PB7 . . . . .	28
1.6.9	PC0–PC7 . . . . .	28
1.6.10	PD0–PD5 and PD7 . . . . .	28

### 1.2 Introduction

The MC68HC05C9A HCMOS (high-density complementary metal-oxide semiconductor) microcontroller is a member of the M68HC05 Family. The MC68HC05C9A memory map consists of 15,936 bytes of user ROM and 352 bytes of RAM. The MC68HC05C9A includes a serial communications interface, a serial peripheral interface, and a 16-bit capture/compare timer.

### 1.3 Features

Features of the MC68HC05C9A include:

- M68HC05 CPU
- Mask programmable interrupt capability on port B
- Software programmable external interrupt sensitivity
- 15,936 bytes of read-only memory (ROM)
- 352 bytes of random-access memory (RAM)
- Memory mapped input/output (I/O)
- 31 bidirectional I/O lines with high current sink and source on PC7
- Asynchronous serial communications interface (SCI)
- Synchronous serial peripheral interface (SPI)
- 16-Bit capture/compare timer
- Computer operating properly (COP) watchdog timer and clock monitor
- Power-saving wait and stop modes
- On-chip crystal oscillator connections
- Single 3.0 volts to 5.5 volts power supply requirement
- ROM contents security<sup>(1)</sup> feature
- Available packages:
  - 40-pin dual in-line (DIP)
  - 44-pin plastic leaded chip carrier (PLCC)
  - 44-pin quad flat pack (QFP)
  - 42-pin plastic shrink dual in-line (SDIP) packages

### 1.4 Mask Options

Eight mask options are available to select external interrupt capability (including an internal pullup device) on each of the port B pins.

1. No security feature is absolutely secure. However, Motorola's strategy is to make reading or copying the ROM difficult for unauthorized users.

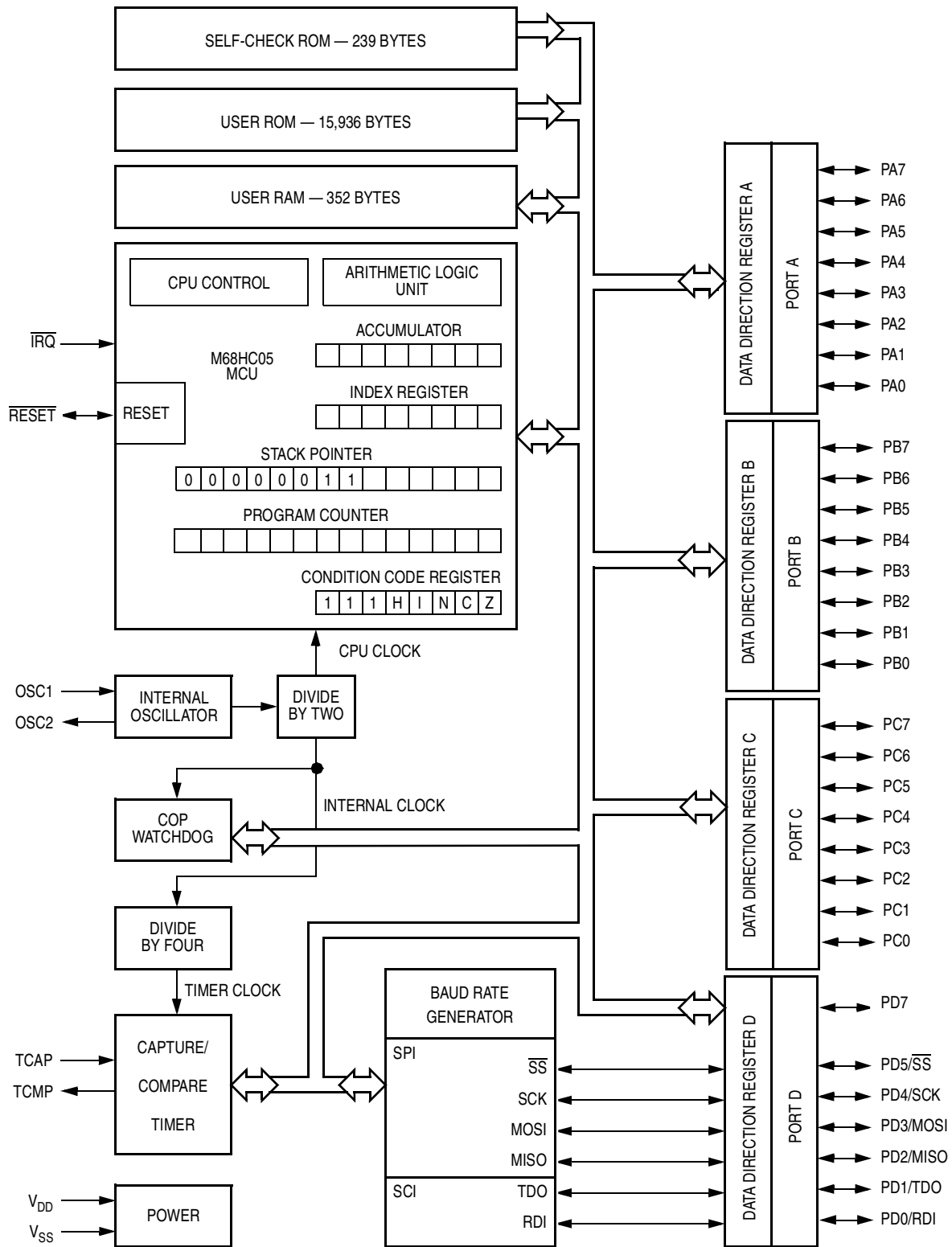

Figure 1-1. Block Diagram

## 1.5 Software-Programmable Options

The option register (OR), shown in **Figure 1-2**, contains the programmable bits for these options:

- Map two different areas of memory between RAM and ROM, one of 48 bytes and one of 128 bytes
- Edge-triggered only or edge- and level-triggered external interrupt (IRQ pin and any port B pin configured for interrupt)

This register must be written to by user software during operation of the microcontroller.

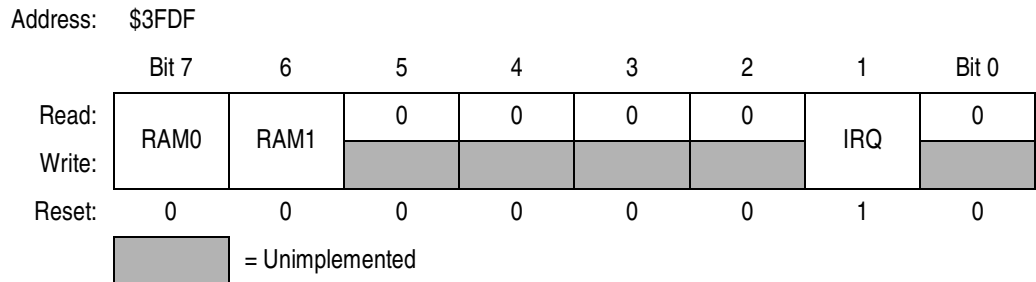

**Figure 1-2. Option Register**

### RAM0 — Random-Access Memory Control Bit 0

This read/write bit selects between RAM or ROM in location \$0020 to \$004F. This bit can be read or written at any time.

1 = RAM selected

0 = ROM selected

### RAM1— Random-Access Memory Control Bit 1

This read/write bit selects between RAM or ROM in location \$0100 to \$017F. This bit can be read or written at any time.

1 = RAM selected

0 = EPROM selected

### IRQ — Interrupt Request Bit

This bit selects between an edge-triggered only or edge- and level-triggered external interrupt. This bit is set by reset, but can be cleared by software. This bit can be written only once.

1 = Edge and level interrupt option selected

0 = Edge-only interrupt option selected

## 1.6 Functional Pin Descriptions

Figure 1-3, Figure 1-4, Figure 1-5, and Figure 1-6 show the pin assignments for the available packages. A functional description of the pins follows.

**NOTE:** A line over a signal name indicates an active low signal. For example, *RESET* is active high and *RESET* is active low.

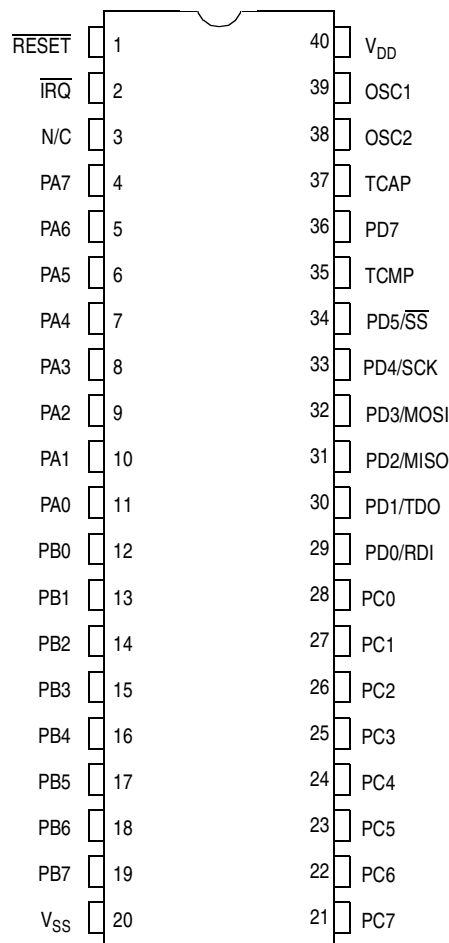

**Figure 1-3. 40-Pin PDIP Pin Assignments**

**NOTE:** If MC68HC705C9A devices are to be used in the same socket, pin 3 should be tied to  $V_{DD}$ .

# General Description

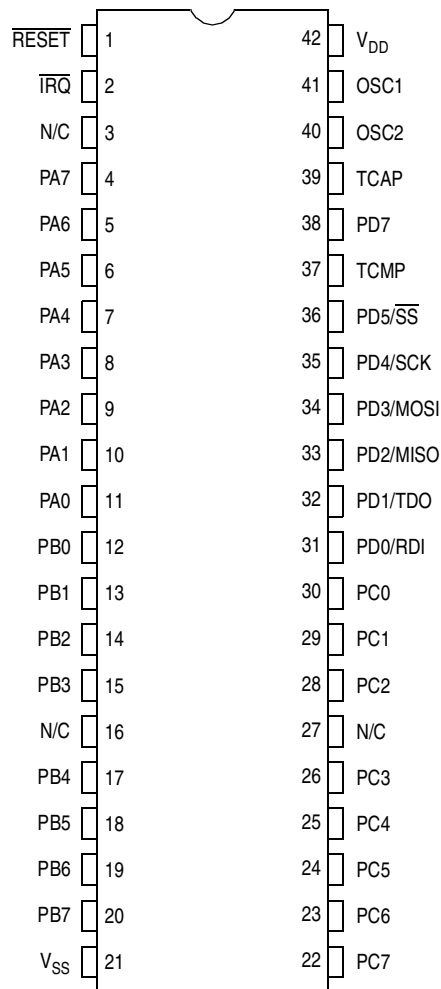

**Figure 1-4. 42-Pin SDIP Pin Assignments**

**NOTE:** If MC68HC705C9A devices are to be used in the same socket, pin 3 should be tied to V<sub>DD</sub>.



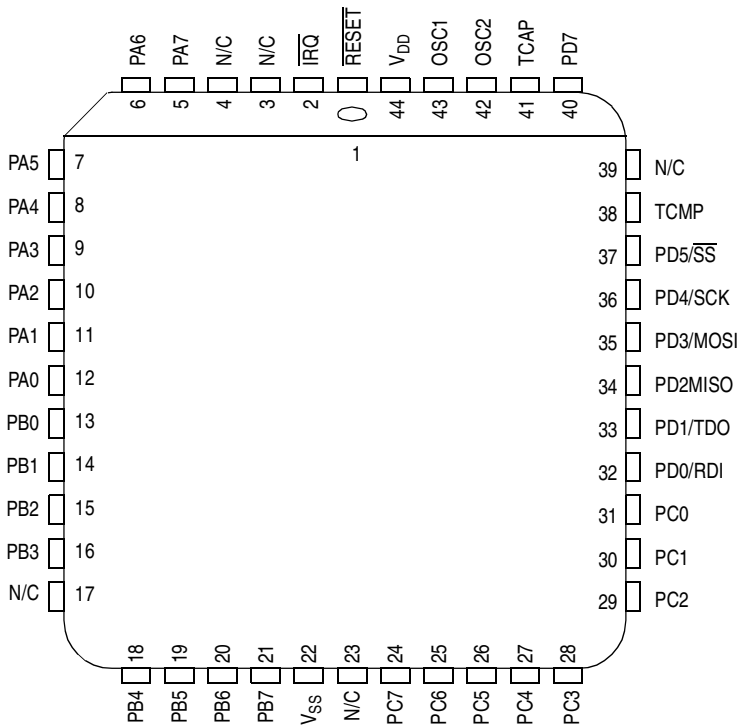
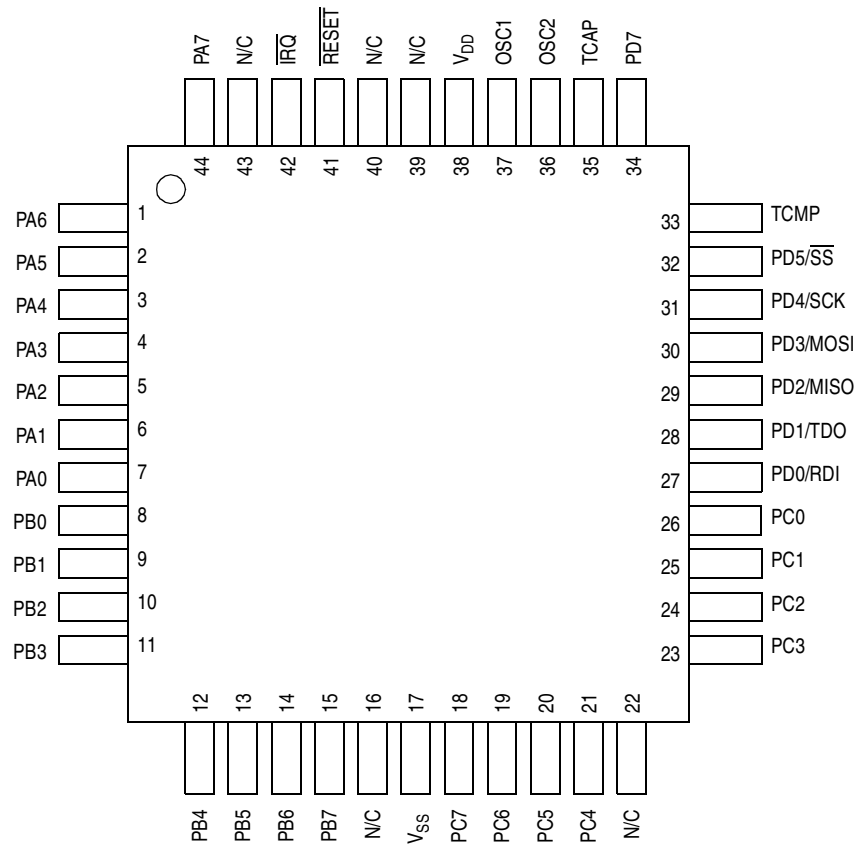

**Figure 1-5. 44-Lead PLCC Pin Assignments**

**NOTE:** The 44-pin PLCC pin assignment diagram is for compatibility with the MC68HC705C9A. However, if MC68HC705C9A devices are to be used in the same socket, pin 3 should be tied to  $V_{DD}$ .

For compatibility with MC68HC05C4A/C8A/C12A devices in 44-pin PLCC, tie pins 17 and 18 together, and tie pins 39 and 40 together.

For compatibility with MC68HC705C8A 44-pin PLCC device, three sets of pins should be tied together: pins 17 and 18, pins 39 and 40, and pins 3, 4, and 44.



**Figure 1-6. 44-Pin QFP Pin Assignments**

**NOTE:** If MC68HC705C9A devices are to be used in the same socket, pin 43 should be tied to  $V_{DD}$ .

## 1.6.1 $V_{DD}$ and $V_{SS}$

Power is supplied to the MCU using these two pins.  $V_{DD}$  is the positive supply and  $V_{SS}$  is ground.

## 1.6.2 $\overline{\text{IRQ}}$

This interrupt pin has an option that provides two different choices of interrupt triggering sensitivity. The  $\overline{\text{IRQ}}$  pin contains an internal Schmitt trigger as part of its input to improve noise immunity. Refer to **Section 4. Interrupts** for more detail.

### 1.6.3 OSC1 and OSC2

These pins provide control input for an on-chip clock oscillator circuit. A crystal or ceramic resonator connected to these pins provides a system clock. The internal frequency is one-half the crystal frequency.

### 1.6.4 $\overline{\text{RESET}}$

As an input pin, this active low  $\overline{\text{RESET}}$  pin is used to reset the MCU to a known startup state by pulling  $\overline{\text{RESET}}$  low. As an output pin, the  $\overline{\text{RESET}}$  pin indicates that an internal MCU reset has occurred. The  $\overline{\text{RESET}}$  pin contains an internal Schmitt trigger as part of its input to improve noise immunity. Refer to **Section 5. Resets** for more detail.

### 1.6.5 TCAP

This pin controls the input capture feature for the on-chip programmable timer. The TCAP pin contains an internal Schmitt trigger as part of its input to improve noise immunity. Refer to **Section 8. Capture/Compare Timer** for more detail.

### 1.6.6 TCMP

The TCMP pin provides an output for the output compare feature of the on-chip programmable timer. Refer to **Section 8. Capture/Compare Timer** for more detail.

### 1.6.7 PA0–PA7

These eight I/O lines comprise port A. The state of each pin is software programmable and all port A pins are configured as inputs during reset. Refer to **Section 7. Input/Output Ports** for more detail.

### 1.6.8 PB0–PB7

These eight I/O lines comprise port B. The state of each pin is software programmable and all port B pins are configured as inputs during reset. Port B has mask option register enabled pullup devices and interrupt capability selectable for any pin. Refer to **Section 7. Input/Output Ports** for more detail.

### 1.6.9 PC0–PC7

These eight I/O lines comprise port C. The state of each pin is software programmable and all port C pins are configured as inputs during reset. PC7 has high current sink and source capability. Refer to **Section 7. Input/Output Ports** for more detail.

### 1.6.10 PD0–PD5 and PD7

These seven I/O lines comprise port D. The state of each pin is software programmable and all port D pins are configured as inputs during reset. Refer to **Section 7. Input/Output Ports** for more detail.

## Section 2. Memory

### 2.1 Contents

2.2	Introduction . . . . .	29
2.3	RAM . . . . .	31
2.4	ROM . . . . .	31
2.5	ROM Security . . . . .	31
2.6	I/O Registers . . . . .	31

### 2.2 Introduction

The microcontroller unit (MCU) has a 16-Kbyte memory map. The memory map consists of:

- Input/output (I/O), control, and status registers
- User random-access memory (RAM)
- User read-only memory (ROM)
- Self-check ROM
- Reset and interrupt vectors

See **Figure 2-1** and **Figure 2-2**.

Two control bits in the option register (\$3FDF) allow the user to switch between RAM and ROM at any time in two special areas of the memory map, \$0020–\$004F (48 bytes) and \$0100–\$017F (128 bytes).



## 2.3 RAM

The main user RAM consists of 176 bytes at \$0050–\$00FF. This RAM area is always present in the memory map and includes a 64-byte stack area. The stack pointer can access 64 bytes of RAM in the range \$00FF down to \$00C0.

**NOTE:** *Using the stack area for data storage or temporary work locations requires care to prevent it from being overwritten due to stacking from an interrupt or subroutine call.*

Two additional RAM areas are available at \$0020–\$004F (48 bytes) and \$0100–\$017F (128 bytes) (see **Figure 2-1** and **Figure 2-2**.) These may be accessed at any time by setting the RAM0 and RAM1 bits, respectively, in the option register.

Refer to **1.5 Software-Programmable Options** for additional information.

## 2.4 ROM

The user ROM consists of 48 bytes of page zero ROM from \$0020 to \$004F, 15,872 bytes of ROM from \$0100 to \$3EFF, and 16 bytes of user vectors from \$3FF0 to \$3FFF.

## 2.5 ROM Security

A security feature has been incorporated into the MC68HC05C9A to help prevent external access to the contents of the ROM in any mode of operation.

## 2.6 I/O Registers

Except for the option register, all I/O, control and status registers are located within one 32-byte block in page zero of the address space (\$0000–\$001F). A summary of these registers is shown in **Figure 2-2**. More detail about the contents of these registers is given in **Figure 2-3**.

Address	Register Name
\$0000	Port A Data Register
\$0001	Port B Data Register
\$0002	Port C Data Register
\$0003	Port D Data Register
\$0004	Port A Data Direction Register
\$0005	Port B Data Direction Register
\$0006	Port C Data Direction Register
\$0007	Port D Data Direction Register
\$0008	Unused
\$0009	Unused
\$000A	Serial Peripheral Control Register
\$000B	Serial Peripheral Status Register
\$000C	Serial Peripheral Data Register
\$000D	Baud Rate Register
\$000E	Serial Communications Control Register 1
\$000F	Serial Communications Control Register 2
\$0010	Serial Communications Status Register
\$0011	Serial Communications Data Register
\$0012	Timer Control Register
\$0013	Timer Status Register
\$0014	Input Capture Register High
\$0015	Input Capture Register Low
\$0016	Output Compare Register High
\$0017	Output Compare Register Low
\$0018	Timer Register High
\$0019	Timer Register Low
\$001A	Alternate Timer Register High
\$001B	Alternate Timer Register Low
\$001C	Unused
\$001D	COP Reset Register
\$001E	COP Control Register
\$001F	Reserved

**Figure 2-2. I/O Register Summary**



Addr.	Register Name	Bit 7	6	5	4	3	2	1	Bit 0	
\$0000	Port A Data Register (PORTA) See page 57.	Read:	PA7	PA6	PA5	PA4	PA3	PA2	PA1	PA0
		Write:								
		Reset:	Unaffected by reset							
\$0001	Port B Data Register (PORTB) See page 58.	Read:	PB7	PB6	PB5	PB4	PB3	PB2	PB1	PB0
		Write:								
		Reset:	Unaffected by reset							
\$0002	Port C Data Register (PORTC) See page 59.	Read:	PC7	PC6	PC5	PC4	PC3	PC2	PC1	PC0
		Write:								
		Reset:	Unaffected by reset							
\$0003	Port D Data Register (PORTD) See page 59.	Read:	PD7		PD5	PD4	PD3	PD2	PD1	PD0
		Write:								
		Reset:	Unaffected by reset							
\$0004	Port A Data Direction Register (DDRA) See page 57.	Read:	DDRA7	DDRA6	DDRA5	DDRA4	DDRA3	DDRA2	DDRA1	DDRA0
		Write:								
		Reset:	0	0	0	0	0	0	0	0
\$0005	Port B Data Direction Register (DDRB) See page 58.	Read:	DDRB7	DDRB6	DDRB5	DDRB4	DDRB3	DDRB2	DDRB1	DDRB0
		Write:								
		Reset:	0	0	0	0	0	0	0	0
\$0006	Port C Data Direction Register (DDRC) See page 59.	Read:	DDRC7	DDRC6	DDRC5	DDRC4	DDRC3	DDRC2	DDRC1	DDRC0
		Write:								
		Reset:	0	0	0	0	0	0	0	0
\$0007	Port D Data Direction Register (DDRD) See page 59.	Read:	DDRC7		DDRC5	DDRC4	DDRC3	DDRC2	DDRC1	DDRC0
		Write:								
		Reset:	0	0	0	0	0	0	0	0
\$0008	Unimplemented									

= Unimplemented    
  = Reserved    
 U = Unaffected

**Figure 2-3. Input/Output Registers (Sheet 1 of 4)**

# Memory

Addr.	Register Name	Bit 7	6	5	4	3	2	1	Bit 0	
\$0009	Unimplemented									
\$000A	SPI Control Register (SPCR) See page 97.	Read:	SPIE	SPE	DWOM	MSTR	CPOL	CPHA	SPR1	SPR0
		Write:								
		Reset:	0	0	0	0	0	1	U	U
\$000B	SPI Status Register (SPSR) See page 99.	Read:	SPIF	WCOL	0	MODF	0	0	0	0
		Write:								
		Reset:	0	0	0	0	0	0	0	0
\$000C	SPI Data Register (SPDR) See page 101.	Read:	SPD7	SPD6	SPD5	SPD4	SPD3	SPD2	SPD1	SPD0
		Write:								
		Reset:	Unaffected by reset							
\$000D	SCI Baud Rate Register BAUD See page 89.	Read:			SCP1	SCP0		SCR2	SCR1	SCR0
		Write:								
		Reset:	—	—	0	0	—	U	U	U
\$000E	SCI Control Register 1 (SCCR1) See page 83.	Read:	R8	T8		M	WAKE			
		Write:								
		Reset:	U	U	0	U	U	0	0	0
\$000F	SCI Control Register 2 (SCCR2) See page 85.	Read:	TIE	TCIE	RIE	ILIE	TE	RE	RMW	SBK
		Write:								
		Reset:	0	0	0	0	0	0	0	0
\$0010	SCI Status Register (SCSR) See page 87.	Read:	TDRE	TC	RDRF	IDLE	OR	NF	FE	
		Write:								
		Reset:	1	1	0	0	0	0	0	—
\$0011	SCI Data Register (SCDR) See page 83.	Read:	SCD7	SCD6	SCD5	SCD4	SCD3	SCD2	SCD1	SCD0
		Write:								
		Reset:	Unaffected by reset							

= Unimplemented    
R = Reserved    
U = Unaffected

**Figure 2-3. Input/Output Registers (Sheet 2 of 4)**

Addr.	Register Name	Bit 7	6	5	4	3	2	1	Bit 0	
\$0012	Timer Control Register (TCR) See page 64.	Read:	ICIE	OCIE	TOIE	0	0	0	IEDG	OLVL
		Write:								
		Reset:	0	0	0	0	0	0	U	0
\$0013	Timer Status Register (TSR) See page 66.	Read:	ICF	OCF	TOF	0	0	0	0	0
		Write:								
		Reset:	U	U	U	0	0	0	0	0
\$0014	Input Capture Register High (ICRH) See page 69.	Read:	Bit 15	Bit 14	Bit 13	Bit 12	Bit 11	Bit 10	Bit 9	Bit 8
		Write:								
		Reset:	Unaffected by reset							
\$0015	Input Capture Register Low (ICRL) See page 69.	Read:	Bit 7	Bit 6	Bit 5	Bit 4	Bit 3	Bit 2	Bit 1	Bit 0
		Write:								
		Reset:	Unaffected by reset							
\$0016	Output Compare Register High (OCRH) See page 70.	Read:	Bit 15	Bit 14	Bit 13	Bit 12	Bit 11	Bit 10	Bit 9	Bit 8
		Write:								
		Reset:	Unaffected by reset							
\$0017	Output Compare Register Low (OCRL) See page 70.	Read:	Bit 7	Bit 6	Bit 5	Bit 4	Bit 3	Bit 2	Bit 1	Bit 0
		Write:								
		Reset:	Unaffected by reset							
\$0018	Timer Register High (TRH) See page 67.	Read:	Bit 15	Bit 14	Bit 13	Bit 12	Bit 11	Bit 10	Bit 9	Bit 8
		Write:								
		Reset:	1	1	1	1	1	1	1	1
\$0019	Timer Register Low (TRL) See page 67.	Read:	Bit 7	Bit 6	Bit 5	Bit 4	Bit 3	Bit 2	Bit 1	Bit 0
		Write:								
		Reset:	1	1	1	1	1	1	0	0
\$001A	Alternate Timer Register High (ATRH) See page 68.	Read:	Bit 15	Bit 14	Bit 13	Bit 12	Bit 11	Bit 10	Bit 9	Bit 8
		Write:								
		Reset:	1	1	1	1	1	1	1	1

= Unimplemented    
R = Reserved    
U = Unaffected

**Figure 2-3. Input/Output Registers (Sheet 3 of 4)**

# Memory

Addr.	Register Name	Bit 7	6	5	4	3	2	1	Bit 0	
\$001B	Alternate Timer Register Low (ATRL) See page 68.	Read:	Bit 7	Bit 6	Bit 5	Bit 4	Bit 3	Bit 2	Bit 1	Bit 0
		Write:								
		Reset:	1	1	1	1	1	1	0	0
\$001C	Unimplemented									
\$001D	COP Reset Register (COPRST) See page 51.	Read:								
		Write:	Bit 7	Bit 6	Bit 5	Bit 4	Bit 3	Bit 2	Bit 1	Bit 0
		Reset:	0	0	0	0	0	0	0	0
\$001E	COP Control Register (COPCR) See page 52.	Read:	0	0	0	COPF	CME	COPE	CM1	CM0
		Write:								
		Reset:	0	0	0	U	0	0	0	0
\$001D	Unimplemented									
\$001E	Unimplemented									
\$001F	Reserved	R	R	R	R	R	R	R	R	

= Unimplemented    
 R = Reserved    
 U = Unaffected

**Figure 2-3. Input/Output Registers (Sheet 4 of 4)**

## Section 3. Central Processor Unit (CPU)

### 3.1 Contents

3.2	Introduction . . . . .	37
3.3	CPU Registers . . . . .	38
3.3.1	Accumulator (A) . . . . .	39
3.3.2	Index Register (X) . . . . .	39
3.3.3	Program Counter (PC) . . . . .	39
3.3.4	Stack Pointer (SP) . . . . .	39
3.3.5	Condition Code Register (CCR) . . . . .	40

### 3.2 Introduction

This section contains information describing the basic programmer's model and the registers contained in the central processor unit (CPU).

## 3.3 CPU Registers

The microcontroller unit (MCU) contains five registers as shown in the programming model of **Figure 3-1**. The interrupt stacking order is shown in **Figure 3-2**.

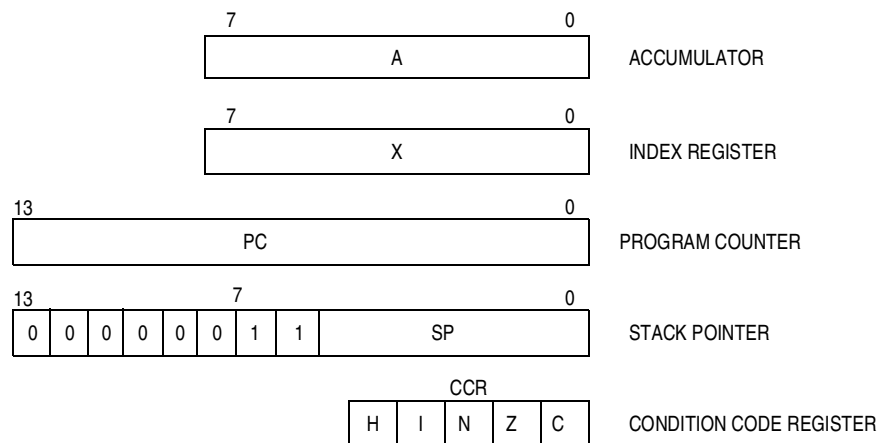

**Figure 3-1. Programming Model**

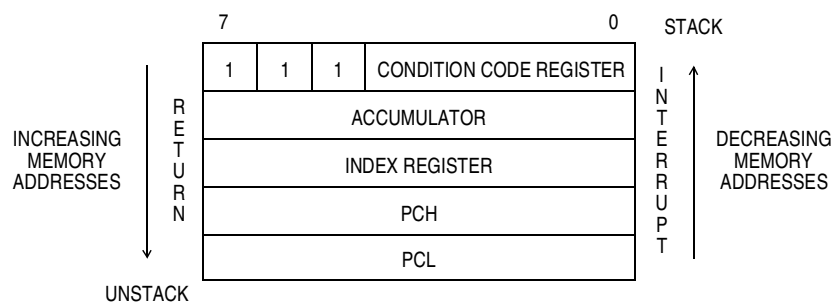

**Figure 3-2. Interrupt Stacking Order**

### 3.3.1 Accumulator (A)

The accumulator is a general-purpose 8-bit register used to hold operands and results of arithmetic calculations or data manipulations.

### 3.3.2 Index Register (X)

The index register is an 8-bit register used for the indexed addressing value to create an effective address. The index register may also be used as a temporary storage area.

### 3.3.3 Program Counter (PC)

The program counter is a 14-bit register that contains the address of the next byte to be fetched.

### 3.3.4 Stack Pointer (SP)

The stack pointer contains the address of the next free location on the stack. During an MCU reset or the reset stack pointer (RSP) instruction, the stack pointer is set to location \$0FF. The stack pointer is then decremented as data is pushed onto the stack and incremented as data is pulled from the stack.

When accessing memory, the eight most significant bits are permanently set to 00000011. These eight bits are appended to the six least significant register bits to produce an address within the range of \$00FF to \$00C0. Subroutines and interrupts may use up to 64 (decimal) locations. If 64 locations are exceeded, the stack pointer wraps around and loses the previously stored information. A subroutine call occupies two locations on the stack; an interrupt uses five locations.

### 3.3.5 Condition Code Register (CCR)

The CCR is a 5-bit register in which four bits are used to indicate the results of the instruction just executed, and the fifth bit indicates whether interrupts are masked. These bits can be individually tested by a program, and specific actions can be taken as a result of their state. Each bit is explained here.

#### Half Carry (H)

This bit is set during ADD and ADC operations to indicate that a carry occurred between bits 3 and 4.

#### Interrupt (I)

When this bit is set, the timer, serial communications interface (SCI), serial peripheral interface (SPI), and external interrupt are masked (disabled). If an interrupt occurs while this bit is set, the interrupt is latched and processed as soon as the interrupt bit is cleared.

#### Negative (N)

When set, this bit indicates that the result of the last arithmetic, logical, or data manipulation was negative.

#### Zero (Z)

When set, this bit indicates that the result of the last arithmetic, logical, or data manipulation was 0.

#### Carry/Borrow (C)

When set, this bit indicates that a carry or borrow out of the arithmetic logical unit (ALU) occurred during the last arithmetic operation. This bit is also affected during bit test and branch instructions and during shifts and rotates.



## Section 4. Interrupts

### 4.1 Contents

4.2	Introduction . . . . .	41
4.3	Non-Maskable Software Interrupt (SWI) . . . . .	42
4.4	External Interrupt ( $\overline{\text{IRQ}}$ or Port B) . . . . .	42
4.5	Timer Interrupt . . . . .	44
4.6	SCI Interrupt . . . . .	44
4.7	SPI Interrupt . . . . .	44

### 4.2 Introduction

The MC68HC05C9A microcontroller unit (MCU) can be interrupted by five different sources: four maskable hardware interrupts, and one non-maskable software interrupt:

- External signal on the  $\overline{\text{IRQ}}$  pin or port B pins
- 16-bit programmable timer
- Serial communications interface (SCI)
- Serial peripheral interface (SPI)
- Software interrupt instruction (SWI)

Interrupts cause the processor to save register contents on the stack and to set the interrupt mask (I bit) to prevent additional interrupts. The return from interrupt (RTI) instruction causes the register contents to be recovered from the stack and normal processing to resume.

Unlike RESET, hardware interrupts do not cause the current instruction execution to be halted, but are considered pending until the current instruction is complete.

**NOTE:** *The current instruction is the one already fetched and being operated on.*

When the current instruction is complete, the processor checks all pending hardware interrupts. If interrupts are not masked (CCR I bit clear) and if the corresponding interrupt enable bit is set, the processor proceeds with interrupt processing; otherwise, the next instruction is fetched and executed.

If an external interrupt and a timer, SCI, or SPI interrupt are pending at the end of an instruction execution, the external interrupt is serviced first. The SWI is executed the same as any other instruction, regardless of the I-bit state.

**Table 4-1** shows the relative priority of all the possible interrupt sources. **Figure 4-1** shows the interrupt processing flow.

## 4.3 Non-Maskable Software Interrupt (SWI)

The SWI is an executable instruction and a non-maskable interrupt. It is executed regardless of the state of the I bit in the CCR. If the I bit is 0 (interrupts enabled), SWI executes after interrupts which were pending when the SWI was fetched, but before interrupts generated after the SWI was fetched. The interrupt service routine address is specified by the contents of memory locations \$3FFC and \$3FFD.

## 4.4 External Interrupt ( $\overline{\text{IRQ}}$ or Port B)

If the interrupt mask bit (I bit) of the CCR is set, all maskable interrupts (internal and external) are disabled. Clearing the I bit enables interrupts. The interrupt request is latched immediately following the falling edge of  $\overline{\text{IRQ}}$ . It is then synchronized internally and serviced as specified by the contents of \$3FFA and \$3FFB.

**Table 4-1. Vector Addresses for Interrupts and Resets**

Function	Source	Local Mask	Global Mask	Priority (1 = Highest)	Vector Address
Reset	Power-on reset	None	None	1	\$3FFE–\$3FFF
	$\overline{\text{RESET}}$ pin				
	COP watchdog				
Software interrupt (SWI)	User code	None	None	Same priority as instruction	\$3FFC–\$3FFD
External interrupt	$\overline{\text{IRQ}}$ pin	None	I bit	2	\$3FFA–\$3FFB
	Port B pins				
Timer interrupts	ICF bit	ICIE bit	I bit	3	\$3FF8–\$3FF9
	OCF bit	OCIE bit			
	TOF bit	TOIE bit			
SCI interrupts	TDRE bit	TCIE bit	I bit	4	\$3FF6–\$3FF7
	TC bit				
	RDRF bit	RIE bit			
	OR bit				
	IDLE bit				
SPI interrupts	SPIF bit	SPIE bit	I bit	5	\$3FF4–\$3FF5
	MODF bit				

When any of the port B pullups are enabled, each pin becomes an additional external interrupt source which is executed identically to the  $\overline{\text{IRQ}}$  pin. Port B interrupts follow the same edge/edge-level selection as the  $\overline{\text{IRQ}}$  pin. The branch instructions BIL and BIH also respond to the port B interrupts in the same way as the  $\overline{\text{IRQ}}$  pin. See **7.4 Port B**.

Either a level-sensitive and edge-sensitive trigger or an edge-sensitive-only trigger operation is selectable. The sensitivity is software-controlled by the IRQ bit in the option register (\$3FDF).

**NOTE:** *The internal interrupt latch is cleared in the first part of the interrupt service routine; therefore, one external interrupt pulse can be latched and serviced as soon as the I bit is cleared.*

## 4.5 Timer Interrupt

Three different timer interrupt flags cause a timer interrupt whenever they are set and enabled. The interrupt flags are in the timer status register (TSR), and the enable bits are in the timer control register (TCR). Any of these interrupts will vector to the same interrupt service routine, located at the address specified by the contents of memory locations \$3FF8 and \$3FF9.

## 4.6 SCI Interrupt

Five different SCI interrupt flags cause an SCI interrupt whenever they are set and enabled. The interrupt flags are in the SCI status register (SCSR), and the enable bits are in the SCI control register 2 (SCCR2). Any of these interrupts will vector to the same interrupt service routine, located at the address specified by the contents of memory locations \$3FF6 and \$3FF7.

## 4.7 SPI Interrupt

Two different SPI interrupt flags cause an SPI interrupt whenever they are set and enabled. The interrupt flags are in the SPI status register (SPSR), and the enable bits are in the SPI control register (SPCR). Either of these interrupts will vector to the same interrupt service routine, located at the address specified by the contents of memory locations \$3FF4 and \$3FF5.

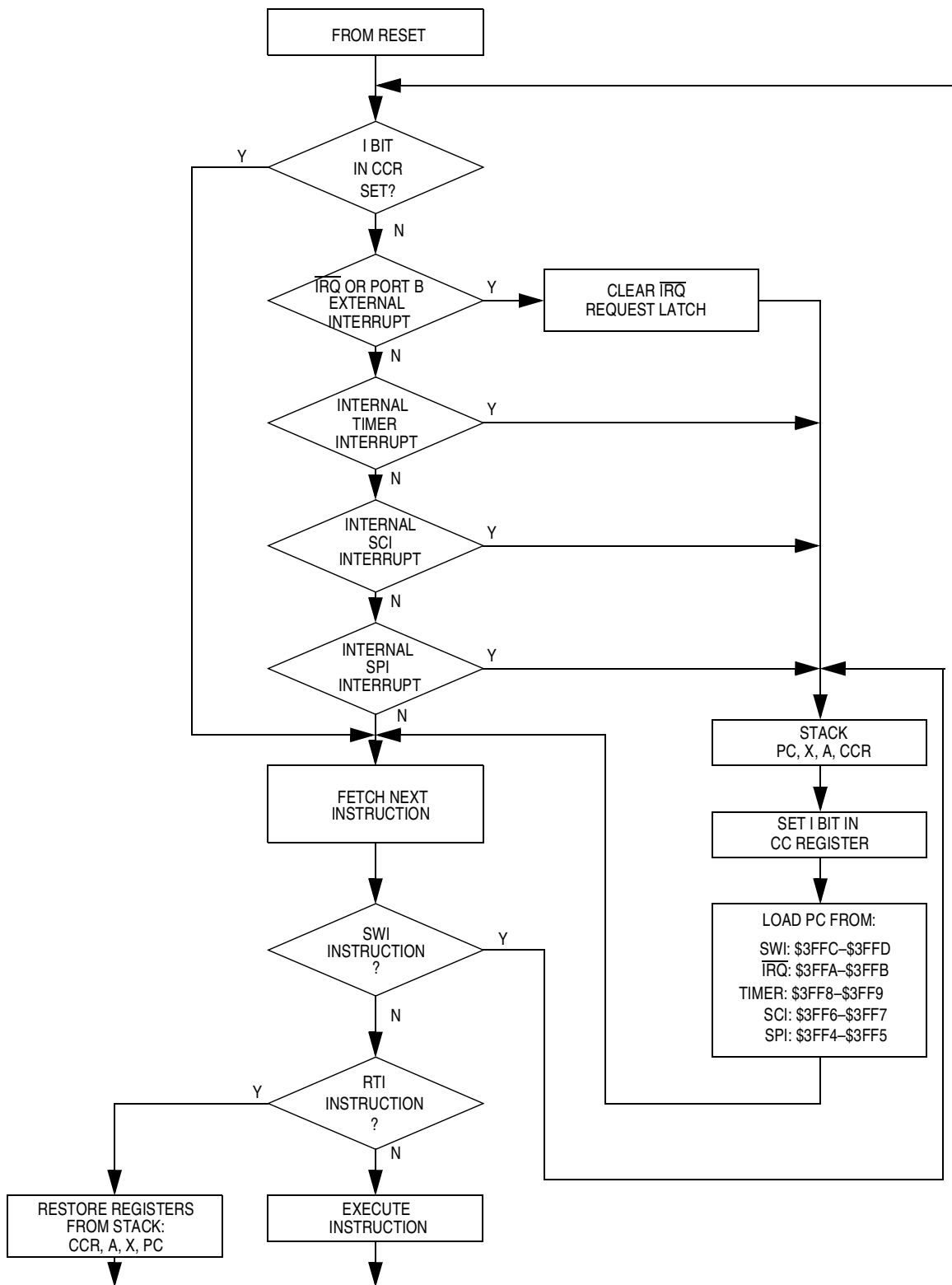

Figure 4-1. Interrupt Flowchart



## Section 5. Resets

### 5.1 Contents

5.2	Introduction . . . . .	47
5.3	Power-On Reset (POR) . . . . .	48
5.4	$\overline{\text{RESET}}$ Pin . . . . .	49
5.5	Computer Operating Properly (COP) Reset . . . . .	50
5.5.1	COP Reset Register . . . . .	51
5.5.2	COP Control Register . . . . .	52
5.6	COP During Wait Mode . . . . .	54
5.7	COP During Stop Mode . . . . .	54
5.8	Clock Monitor Reset . . . . .	54

### 5.2 Introduction

The MC68HC05C9A microcontroller unit (MCU) can be reset four ways:

- Initial power-on reset function
- Active low input to the  $\overline{\text{RESET}}$  pin
- Computer operating properly (COP)
- Clock monitor

A reset immediately stops the operation of the instruction being executed, initializes some control bits, and loads the program counter with a user-defined reset vector address. **Figure 5-1** is a block diagram of the reset sources.

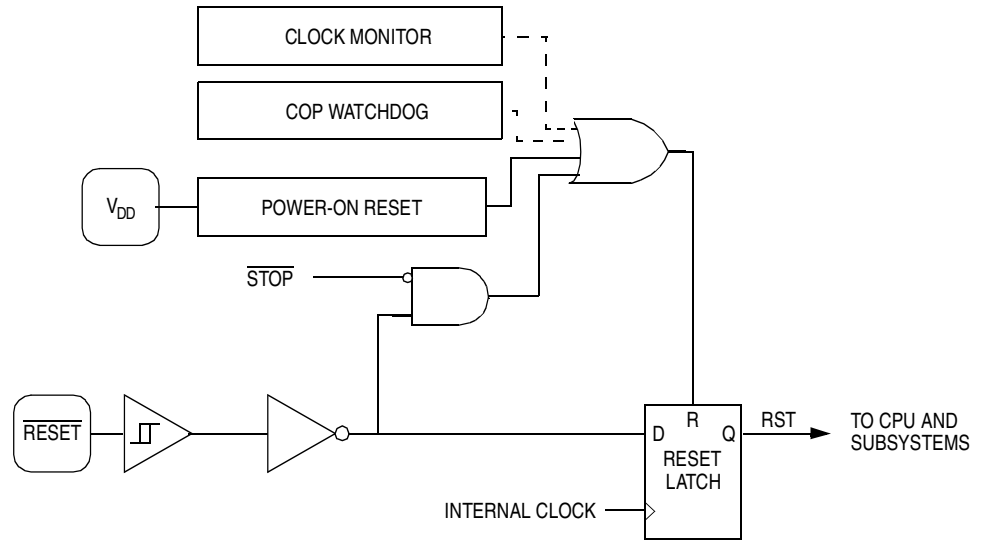

**Figure 5-1. Reset Sources**

## 5.3 Power-On Reset (POR)

A power-on reset (POR) occurs when a positive transition is detected on  $V_{DD}$ . The power-on reset is strictly for power turn-on conditions and should not be used to detect a drop in the power supply voltage. There is a 4064 internal processor clock cycle ( $t_{CYC}$ ) oscillator stabilization delay after the oscillator becomes active. The  $\overline{\text{RESET}}$  pin will output a logic 0 during the 4064-cycle delay. If the  $\overline{\text{RESET}}$  pin is low after the end of this 4064-cycle delay, the MCU will remain in the reset condition until  $\overline{\text{RESET}}$  is driven high externally.



## 5.4 $\overline{\text{RESET}}$ Pin

The MCU is reset when a logic 0 is applied to the  $\overline{\text{RESET}}$  input for a period of one and one-half machine cycles ( $t_{RL}$ ). However, to differentiate between an external reset and an internal reset (generated from the COP or clock monitor), any externally driven reset must be active (logic 0) for at least eight  $t_{CYC}$ .

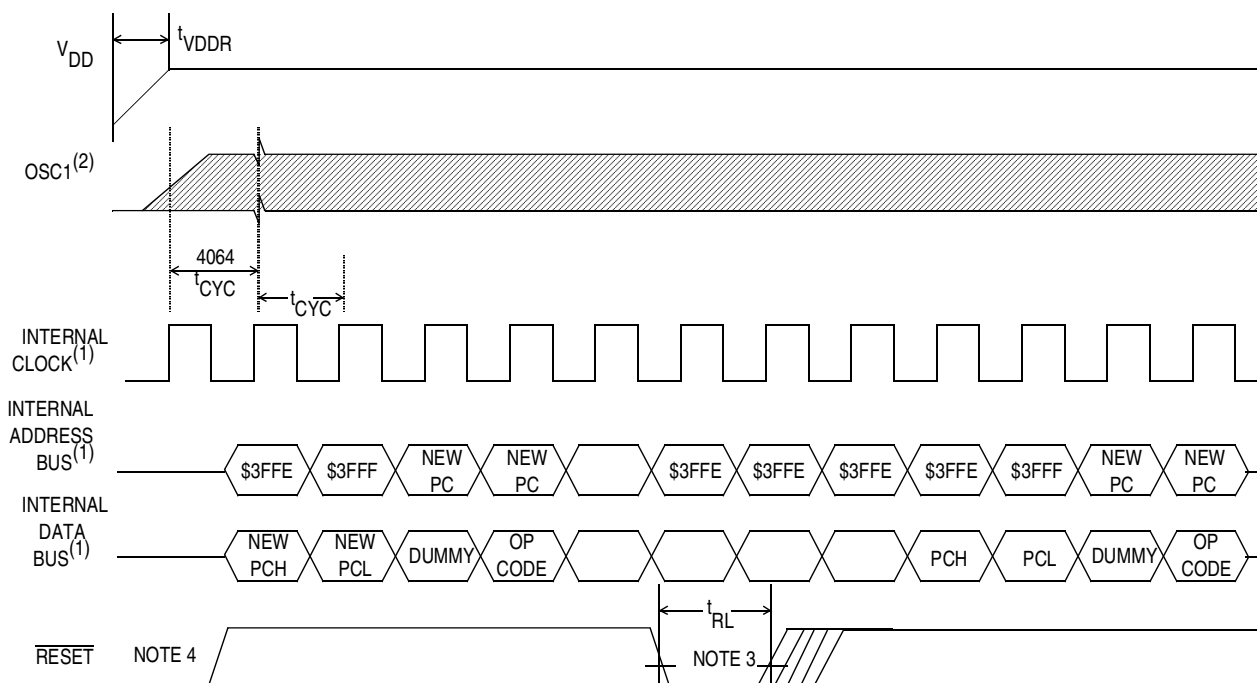

Notes:

1. Internal timing signal and bus information are not available externally.
2. OSC1 line is not meant to represent frequency. It is meant to represent only time.
3. The next rising edge of the internal processor clock following the rising edge of  $\overline{\text{RESET}}$  initiates the reset sequence.
4.  $\overline{\text{RESET}}$  outputs  $V_{OL}$  during 4064 power-on reset cycles.

**Figure 5-2. Power-On Reset and  $\overline{\text{RESET}}$**

### 5.5 Computer Operating Properly (COP) Reset

This device includes a watchdog COP feature which guards against program run-away failures. A timeout of the COP timer generates a COP reset. The COP watchdog is a software error detection system that automatically times out and resets the MCU if not cleared periodically by a program sequence.

The COP is controlled with two registers, one to reset the COP timer and the other to enable and control COP and clock monitor functions.

**Figure 5-3** shows a block diagram of the COP.

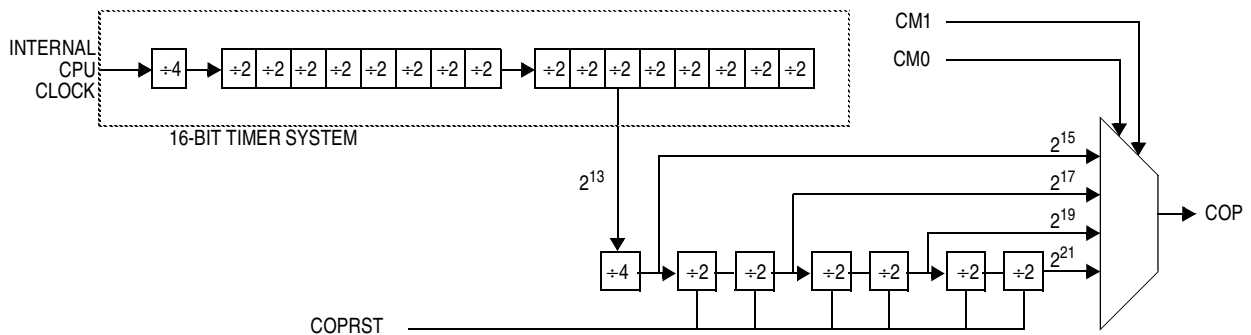

**Figure 5-3. COP Block Diagram**

### 5.5.1 COP Reset Register

The COP reset register (COPRST), shown in **Figure 5-4**, is a write-only register used to reset the COP.

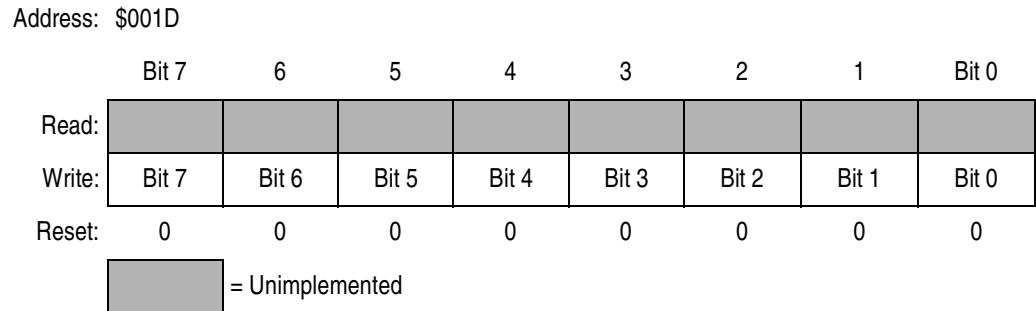

**Figure 5-4. COP Reset Register (COPRST)**

The sequence required to reset the COP timer is:

- Write \$55 to the COP reset register
- Write \$AA to the COP reset register

Both write operations must occur in the order listed, but any number of instructions may be executed between the two write operations provided that the COP does not time out between the two writes. The elapsed time between software resets must not be greater than the COP timeout period. If the COP should time out, a system reset will occur and the device will be re-initialized in the same fashion as a power-on reset or reset.

Reading this register does not return valid data.

## 5.5.2 COP Control Register

The COP control register (COPCR), shown in **Figure 5-5**, performs these functions:

- Enables clock monitor function
- Enables COP function
- Selects timeout duration of COP timer

And flags these conditions:

- COP timeout
- Clock monitor reset

Address: \$001E

	Bit 7	6	5	4	3	2	1	Bit 0
Read:	0	0	0	COPF	CME	COPE	CM1	CM0
Write:								
Reset:	0	0	0	U	0	0	0	0

= Unimplemented      U = Undetermined

**Figure 5-5. COP Control Register (COPCR)**

**COPF** — Computer Operating Properly Flag

Reading the COP control register clears COPF.

1 = COP or clock monitor reset has occurred.

0 = No COP or clock monitor reset has occurred.

**CME** — Clock Monitor Enable Bit

This bit is readable any time, but may be written only once.

1 = Clock monitor enabled

0 = Clock monitor disabled

### COPE — COP Enable Bit

This bit is readable any time. COPE, CM1, and CM0 together may be written with a single write, only once, after reset. This bit is cleared by reset.

- 1 = COP enabled
- 0 = COP disabled

### CM1 — COP Mode Bit 1

Used in conjunction with CM0 to establish the COP timeout period, this bit is readable any time. COPE, CM1, and CM0 together may be written with a single write, only once, after reset. This bit is cleared by reset. See **Table 5-1** for timeout period options.

### CM0 — COP Mode Bit 0

Used in conjunction with CM1 to establish the COP timeout period, this bit is readable any time. COPE, CM1, and CM0 together may be written with a single write, only once, after reset. This bit is cleared by reset. See **Table 5-1** for timeout period options.

### Bits 7–5 — Not Used

These bits always read as 0.

**Table 5-1. COP Timeout Period**

CM1	CM0	$f_{OP}/2^{15}$ Divide By	Timeout Period ( $f_{OSC} = 2.0$ MHz)	Timeout Period ( $f_{OSC} = 4.0$ MHz)
0	0	1	32.77 ms	16.38 ms
0	1	4	131.07 ms	65.54 ms
1	0	16	524.29 ms	262.14 ms
1	1	64	2.097 s	1.048 s

### 5.6 COP During Wait Mode

The COP will continue to operate normally during wait mode. The software must pull the device out of wait mode periodically and reset the COP to prevent a system reset.

### 5.7 COP During Stop Mode

Stop mode disables the oscillator circuit and thereby turns the clock off for the entire device. The COP counter will be reset when stop mode is entered. If a reset is used to exit stop mode, the COP counter will be reset after the 4064 cycles of delay after stop mode. If an IRQ is used to exit stop mode, the COP counter will not be reset after the 4064-cycle delay and will have that many cycles already counted when control is returned to the program.

In the event that an inadvertent STOP instruction is executed, the COP will not provide a reset. The clock monitor function provides protection for this situation.

### 5.8 Clock Monitor Reset

The clock monitor circuit can provide a system reset if the clock stops for any reason, including stop mode. When the CME bit in the COP control register is set, the clock monitor detects the absence of the internal bus clock for a certain period of time. The timeout period is dependent on the processing parameters and varies from 5  $\mu$ s to 100  $\mu$ s, which implies that systems using a bus clock rate of 200 kHz or less should not use the clock monitor.

If a slow or absent clock is detected, the clock monitor causes a system reset. The reset is issued to the external system via the bidirectional RESET pin for four bus cycles if the clock is slow or until the clocks recover in the case where the clocks are absent.

## Section 6. Low-Power Modes

### 6.1 Contents

6.2	Introduction . . . . .	55
6.3	Stop Mode . . . . .	55
6.4	Wait Mode . . . . .	56

### 6.2 Introduction

This section describes the low-power stop and wait modes.

### 6.3 Stop Mode

The STOP instruction places the microcontroller unit (MCU) in its lowest-power consumption mode. In stop mode, the internal oscillator is turned off, halting all internal processing, including timer operation.

During stop mode, the TCR bits are altered to remove any pending timer interrupt request and to disable any further timer interrupts. The timer prescaler is cleared. The I bit in the condition code register (CCR) is cleared to enable external interrupts. All other registers and memory remain unaltered. All input/output (I/O) lines remain unchanged. The processor can be brought out of stop mode only by an external interrupt or reset. See **Figure 6-1**.

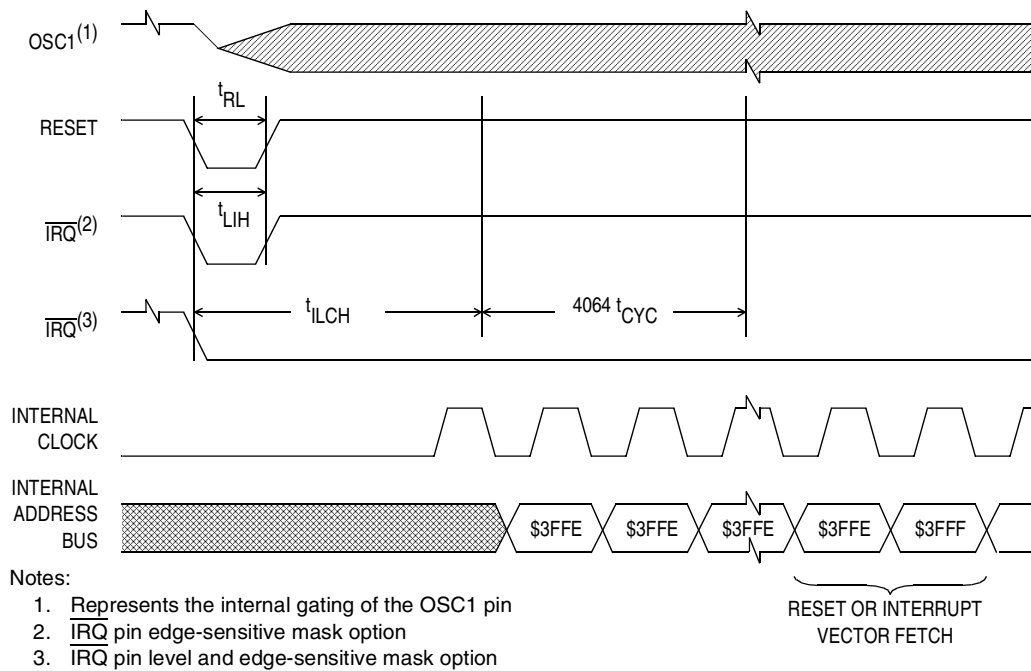

**Figure 6-1. Stop Recovery Timing Diagram**

## 6.4 Wait Mode

The WAIT instruction places the MCU in a low-power consumption mode, but wait mode consumes more power than stop mode. All central processor unit (CPU) action is suspended, but the timer, serial communications interface (SCI), serial peripheral interface (SPI), and the oscillator remain active. Any interrupt or reset will cause the MCU to exit wait mode.

During wait mode, the I bit in the CCR is cleared to enable interrupts. All other registers, memory, and I/O lines remain in their previous state. The timer, SCI, and SPI may be enabled to allow a periodic exit from the wait mode.



## Section 7. Input/Output Ports

### 7.1 Contents

7.2	Introduction . . . . .	57
7.3	Port A . . . . .	57
7.4	Port B . . . . .	58
7.5	Port C . . . . .	59
7.6	Port D . . . . .	59

### 7.2 Introduction

This section briefly describes the 31 input/output (I/O) lines arranged as one 7-bit and three 8-bit ports. All of these port pins are programmable as either inputs or outputs under software control of the data direction registers.

**NOTE:** *To avoid a glitch on the output pins, write data to the I/O port data register before writing a 1 to the corresponding data direction register.*

### 7.3 Port A

Port A is an 8-bit bidirectional port which does not share any of its pins with other subsystems. The port A data register is at \$0000 and the data direction register (DDR) is at \$0004. The contents of the port A data register are indeterminate at initial power-up and must be initialized by user software. Reset does not affect the data registers, but clears the data direction registers, thereby returning the ports to inputs. Writing a 1 to a DDR bit sets the corresponding port bit to output mode. A block diagram of the port logic is shown in **Figure 7-1**.

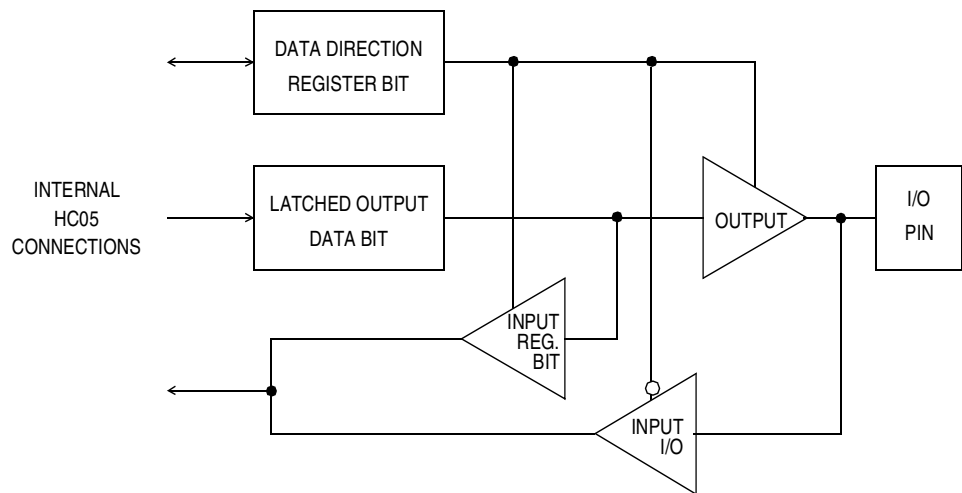

**Figure 7-1. Port A I/O Circuit**

## 7.4 Port B

Port B is an 8-bit bidirectional port. The port B data register is at \$0001 and the data direction register (DDR) is at \$0005. The contents of the port B data register are indeterminate at initial powerup and must be initialized by user software. Reset does not affect the data registers, but clears the data direction registers, thereby returning the ports to inputs. Writing a one to a DDR bit sets the corresponding port pin to output mode. Each of the port B pins has an optional external interrupt capability that can be enabled by mask option.

The interrupt option also enables a pullup device when the pin is configured as an input. The edge or edge- and level-sensitivity of the  $\overline{\text{IRQ}}$  pin will also pertain to the enabled port B pins. Care needs to be taken when using port B pins that have the pullup enabled. Before switching from an output to an input, the data should be preconditioned to a 1 to prevent an interrupt from occurring. The port B logic is shown in **Figure 7-2**.

## 7.5 Port C

Port C is an 8-bit bidirectional port. The port C data register is at \$0002 and the data direction register (DDR) is at \$0006. The contents of the port C data register are indeterminate at initial powerup and must be initialized by user software. Reset does not affect the data registers, but clears the data direction registers, thereby returning the ports to inputs. Writing a 1 to a DDR bit sets the corresponding port bit to output mode. PC7 has a high current sink and source capability. **Figure 7-1** is also applicable to port C.

## 7.6 Port D

Port D is a 7-bit bidirectional port. Four of its pins are shared with the SPI subsystem and two more are shared with the SCI subsystem. The port D data register is at \$0003 and the data direction register is at \$0007. The contents of the port D data register are indeterminate at initial powerup and must be initialized by user software. During reset all seven bits become valid input ports because the DDR bits are cleared and the special function output drivers associated with the SCI and SPI subsystems are disabled, thereby returning the ports to inputs. Writing a 1 to a DDR bit sets the corresponding port bit to output mode.

# Input/Output Ports

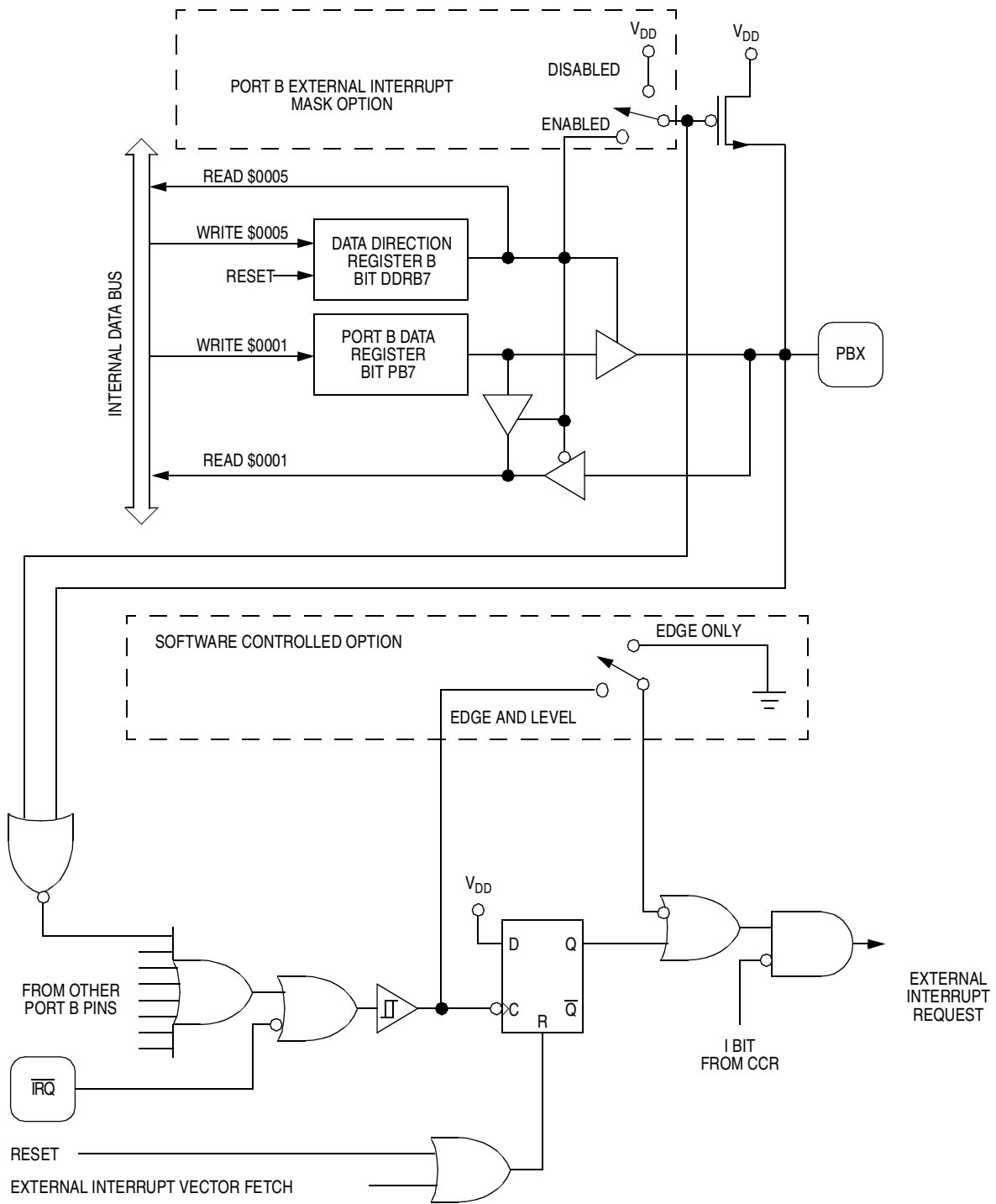

**Figure 7-2. Port B I/O Logic**

## Section 8. Capture/Compare Timer

### 8.1 Content

8.2	Introduction . . . . .	61
8.3	Timer Operation . . . . .	62
8.3.1	Input Capture . . . . .	63
8.3.2	Output Compare . . . . .	63
8.4	Timer I/O Registers . . . . .	64
8.4.1	Timer Control Register . . . . .	64
8.4.2	Timer Status Register . . . . .	66
8.4.3	Timer Registers . . . . .	67
8.4.4	Alternate Timer Registers . . . . .	68
8.4.5	Input Capture Registers . . . . .	69
8.4.6	Output Compare Registers . . . . .	70
8.5	Timer During Wait Mode . . . . .	71
8.6	Timer During Stop Mode . . . . .	71

### 8.2 Introduction

This section describes the operation of the 16-bit capture/compare timer. **Figure 8-1** shows the structure of the capture/compare subsystem.

# Capture/Compare Timer

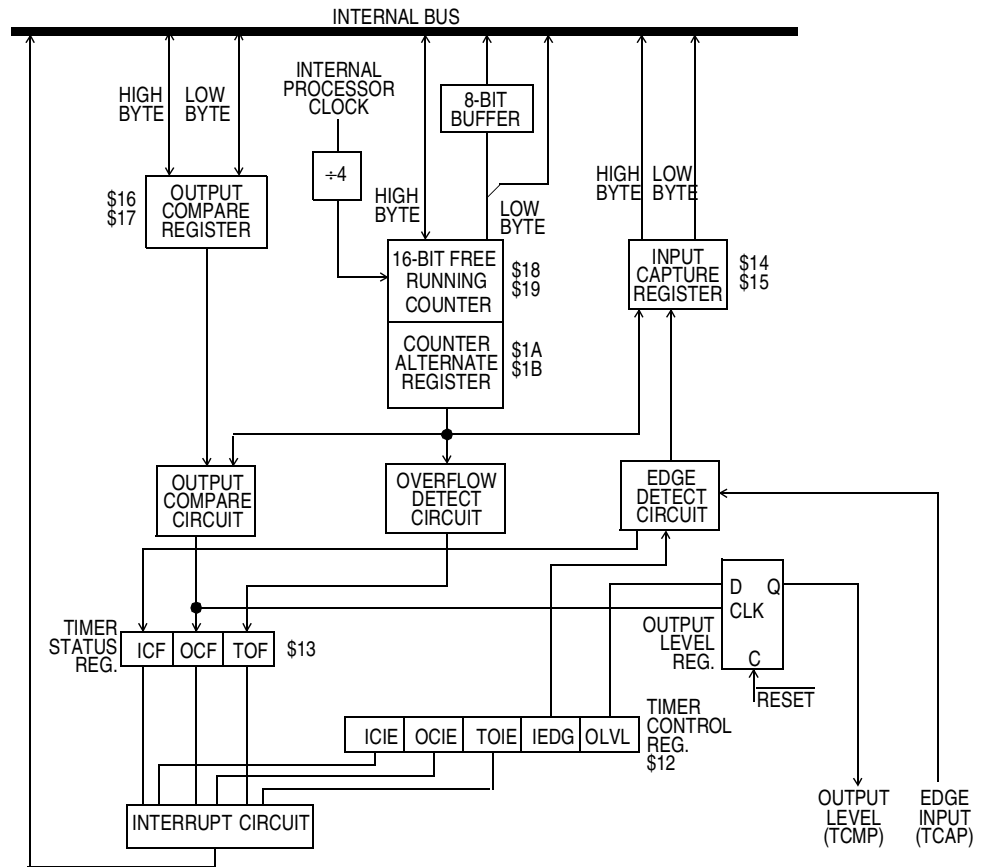

**Figure 8-1. Capture/Compare Timer Block Diagram**

## 8.3 Timer Operation

The core of the capture/compare timer is a 16-bit free-running counter. The counter provides the timing reference for the input capture and output compare functions. The input capture and output compare functions provide a means to latch the times at which external events occur, to measure input waveforms, and to generate output waveforms and timing delays. Software can read the value in the 16-bit free-running counter at any time without affecting the counter sequence.

Because of the 16-bit timer architecture, the input/output (I/O) registers for the input capture and output compare functions are pairs of 8-bit registers.

Because the counter is 16 bits long and preceded by a fixed divide-by-4 prescaler, the counter rolls over every 262,144 internal clock cycles. Timer resolution with a 4-MHz crystal is 2  $\mu$ s.

### 8.3.1 Input Capture

The input capture function is a means to record the time at which an external event occurs. When the input capture circuitry detects an active edge on the TCAP pin, it latches the contents of the timer registers into the input capture registers. The polarity of the active edge is programmable.

Latching values into the input capture registers at successive edges of the same polarity measures the period of the input signal on the TCAP pin. Latching values into the input capture registers at successive edges of opposite polarity measures the pulse width of the signal.

### 8.3.2 Output Compare

The output compare function is a means of generating an output signal when the 16-bit counter reaches a selected value. Software writes the selected value into the output compare registers. On every fourth internal clock cycle the output compare circuitry compares the value of the counter to the value written in the output compare registers. When a match occurs, the timer transfers the programmable output level bit (OLVL) from the timer control register to the TCMP pin.

The programmer can use the output compare register to measure time periods, to generate timing delays, or to generate a pulse of specific duration or a pulse train of specific frequency and duty cycle on the TCMP pin.

## 8.4 Timer I/O Registers

These I/O registers control and monitor timer operation:

- Timer control register (TCR)
- Timer status register (TSR)
- Timer registers (TRH and TRL)
- Alternate timer registers (ATRH and ATRL)
- Input capture registers (ICRH and ICRL)
- Output compare registers (OCRH and OCRL)

### 8.4.1 Timer Control Register

The timer control register (TCR), shown in **Figure 8-2**, performs these functions:

- Enables input capture interrupts
- Enables output compare interrupts
- Enables timer overflow interrupts
- Controls the active edge polarity of the TCAP signal
- Controls the active level of the TCMP output

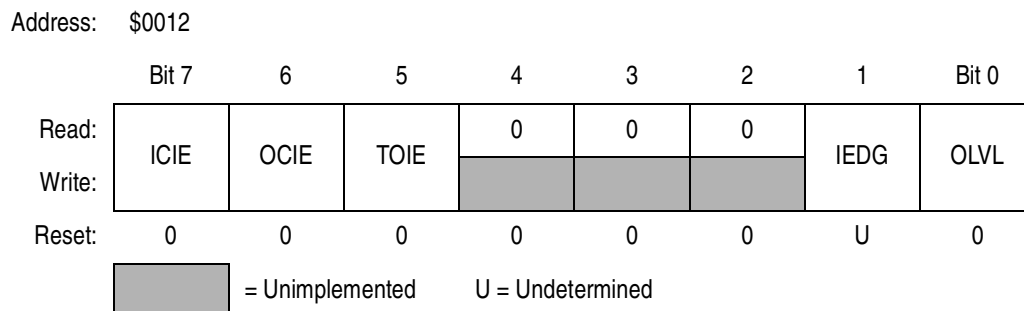

**Figure 8-2. Timer Control Register (TCR)**



#### ICIE — Input Capture Interrupt Enable Bit

This read/write bit enables interrupts caused by an active signal on the TCAP pin. Reset clears the ICIE bit.

- 1 = Input capture interrupts enabled
- 0 = Input capture interrupts disabled

#### OCIE — Output Compare Interrupt Enable Bit

This read/write bit enables interrupts caused by an active signal on the TCMP pin. Reset clears the OCIE bit.

- 1 = Output compare interrupts enabled
- 0 = Output compare interrupts disabled

#### TOIE — Timer Overflow Interrupt Enable Bit

This read/write bit enables interrupts caused by a timer overflow. Reset clears the TOIE bit.

- 1 = Timer overflow interrupts enabled
- 0 = Timer overflow interrupts disabled

#### IEDG — Input Edge Bit

The state of this read/write bit determines whether a positive or negative transition on the TCAP pin triggers a transfer of the contents of the timer register to the input capture register. Resets have no effect on the IEDG bit.

- 1 = Positive edge (low to high transition) triggers input capture.
- 0 = Negative edge (high to low transition) triggers input capture.

#### OLVL — Output Level Bit

The state of this read/write bit determines whether a logic 1 or logic 0 appears on the TCMP pin when a successful output compare occurs. Reset clears the OLVL bit.

- 1 = TCMP goes high on output compare.
- 0 = TCMP goes low on output compare.

## 8.4.2 Timer Status Register

The timer status register (TSR), shown in **Figure 8-3**, contains flags to signal these conditions:

- An active signal on the TCAP pin, transferring the contents of the timer registers to the input capture registers
- A match between the 16-bit counter and the output compare registers, transferring the OLVL bit to the TCMP pin
- A timer roll over from \$FFFF to \$0000

Address: \$0013

	Bit 7	6	5	4	3	2	1	Bit 0
Read:	ICF	OCF	TOF	0	0	0	0	0
Write:								
Reset:	U	U	U	0	0	0	0	0

= Unimplemented    U = Unaffected

**Figure 8-3. Timer Status Register (TSR)**

### ICF — Input Capture Flag

The ICF bit is set automatically when an edge of the selected polarity occurs on the TCAP pin. Clear the ICF bit by reading the timer status register with ICF set and then reading the low byte (\$0015) of the input capture registers. Resets have no effect on ICF.

### OCF — Output Compare Flag

The OCF bit is set automatically when the value of the timer registers matches the contents of the output compare registers. Clear the OCF bit by reading the timer status register with OCF set and then reading the low byte (\$0017) of the output compare registers. Resets have no effect on OCF.

### TOF — Timer Overflow Flag

The TOF bit is set automatically when the 16-bit counter rolls over from \$FFFF to \$0000. Clear the TOF bit by reading the timer status register with TOF set, and then reading the low byte (\$0019) of the timer registers. Resets have no effect on TOF.

### 8.4.3 Timer Registers

The timer registers (TRH and TRL), shown in **Figure 8-4**, contain the current high and low bytes of the 16-bit counter. Reading TRH before reading TRL causes TRL to be latched until TRL is read. Reading TRL after reading the timer status register clears the timer overflow flag (TOF). Writing to the timer registers has no effect.

Address: \$0018 — TRH

	Bit 7	6	5	4	3	2	1	Bit 0
Read:	Bit 15	Bit 14	Bit 13	Bit 12	Bit 11	Bit 10	Bit 9	Bit 8
Write:								
Reset:	1	1	1	1	1	1	1	1

Address: \$0019 — TRL

	Bit 7	6	5	4	3	2	1	Bit 0
Read:	Bit 7	Bit 6	Bit 5	Bit 4	Bit 3	Bit 2	Bit 1	Bit 0
Write:								
Reset:	1	1	1	1	1	1	0	0

 = Unimplemented

**Figure 8-4. Timer Registers (TRH and TRL)**

## 8.4.4 Alternate Timer Registers

The alternate timer registers (ATRH and ATRL), shown in **Figure 8-5**, contain the current high and low bytes of the 16-bit counter. Reading ATRH before reading ATRL causes ATRL to be latched until ATRL is read. Reading ATRL has no effect on the timer overflow flag (TOF). Writing to the alternate timer registers has no effect.

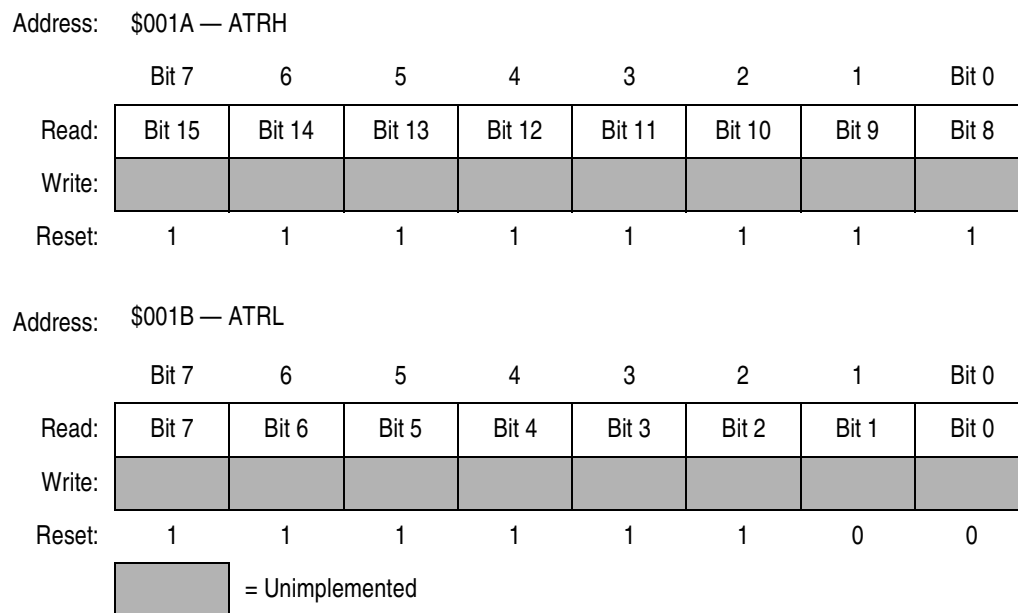

**Figure 8-5. Alternate Timer Registers (ATRH and ATRL)**

**NOTE:** To prevent interrupts from occurring between readings of ATRH and ATRL, set the interrupt flag in the condition code register before reading ATRH, and clear the flag after reading ATRL.

### 8.4.5 Input Capture Registers

When a selected edge occurs on the TCAP pin, the current high and low bytes of the 16-bit counter are latched into the input capture registers. Reading ICRH before reading ICRL inhibits further capture until ICRL is read. Reading ICRL after reading the status register clears the input capture flag (ICF). Writing to the input capture registers has no effect.

Address: \$0014 — ICRH

	Bit 7	6	5	4	3	2	1	Bit 0
Read:	Bit 15	Bit 14	Bit 13	Bit 12	Bit 11	Bit 10	Bit 9	Bit 8
Write:								
Reset:	Unaffected by reset							

Address: \$0015 — ICRL

	Bit 7	6	5	4	3	2	1	Bit 0
Read:	Bit 7	Bit 6	Bit 5	Bit 4	Bit 3	Bit 2	Bit 1	Bit 0
Write:								
Reset:	Unaffected by reset							

 = Unimplemented

**Figure 8-6. Input Capture Registers (ICRH and ICRL)**

**NOTE:** *To prevent interrupts from occurring between readings of ICRH and ICRL, set the interrupt flag in the condition code register before reading ICRH, and clear the flag after reading ICRL.*

## 8.4.6 Output Compare Registers

When the value of the 16-bit counter matches the value in the output compare registers, the planned TCMP pin action takes place. Writing to OCRH before writing to OCRL inhibits timer compares until OCRL is written. Reading or writing to OCRL after the timer status register clears the output compare flag (OCF).

Address: \$0016 — OCRH

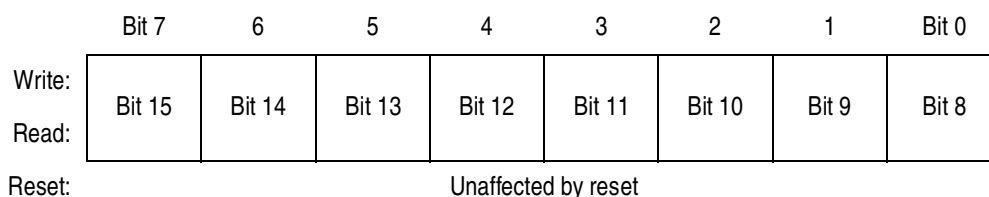

Address: \$0017 — OCRL

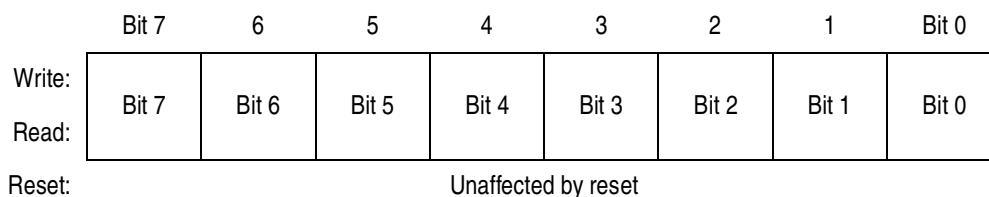

**Figure 8-7. Output Compare Registers (OCRH and OCRL)**

To prevent OCF from being set between the time it is read and the time the output compare registers are updated, use this procedure:

1. Disable interrupts by setting the I bit in the CCR.
2. Write to OCRH. Compares are now inhibited until OCRL is written.
3. Clear bit OCF by reading timer status register (TSR).
4. Enable the output compare function by writing to OCRL.
5. Enable interrupts by clearing the I bit in the CCR.

## 8.5 Timer During Wait Mode

The central processor unit (CPU) clock halts during wait mode, but the timer remains active. If interrupts are enabled, a timer interrupt will cause the processor to exit wait mode.

## 8.6 Timer During Stop Mode

In stop mode, the timer stops counting and holds the last count value if STOP is exited by an interrupt. If STOP is exited by reset, the counters are forced to \$FFFC. During STOP, if at least one valid input capture edge occurs at the TCAP pins, the input capture detect circuit is armed. This does not set any timer flags or wake up the microcontroller unit (MCU). But if an interrupt is used to exit stop mode, there is an active input capture flag and data from the first valid edge that occurred during the stop mode. If reset is used to exit stop mode, then no input capture flag or data remains, even if a valid input capture edge occurred.





## Section 9. Serial Communications Interface (SCI)

### 9.1 Content

9.2	Introduction . . . . .	74
9.3	Features . . . . .	74
9.4	SCI Receiver Features . . . . .	76
9.5	SCI Transmitter Features . . . . .	76
9.6	Functional Description . . . . .	76
9.7	Data Format . . . . .	78
9.8	Receiver Wakeup Operation. . . . .	78
9.8.1	Idle Line Wakeup. . . . .	79
9.8.2	Address Mark Wakeup . . . . .	79
9.9	Receive Data In (RDI). . . . .	80
9.10	Start Bit Detection. . . . .	81
9.11	Transmit Data Out (TDO) . . . . .	82
9.12	SCI I/O Registers . . . . .	82
9.12.1	SCI Data Register . . . . .	83
9.12.2	SCI Control Register 1 . . . . .	83
9.12.3	SCI Control Register 2 . . . . .	84
9.12.4	SCI Status Register. . . . .	87
9.12.5	Baud Rate Register. . . . .	89

## 9.2 Introduction

This section describes the on-chip asynchronous serial communications interface (SCI). The SCI allows full-duplex, asynchronous, RS232 or RS422 serial communication between the microcontroller unit (MCU) and remote devices, including other MCUs. The transmitter and receiver of the SCI operate independently, although they use the same baud rate generator.

## 9.3 Features

Features of the SCI include:

- Standard mark/space non-return-to-zero format
- Full-duplex operation
- 32 programmable baud rates
- Programmable 8-bit or 9-bit character length
- Separately enabled transmitter and receiver
- Two receiver wakeup methods:
  - Idle line wakeup
  - Address mark wakeup
- Interrupt-driven operation capability with five interrupt flags:
  - Transmitter data register empty
  - Transmission complete
  - Transmission data register full
  - Receiver overrun
  - Idle receiver input
- Receiver framing error detection
- 1/16 bit-time noise detection

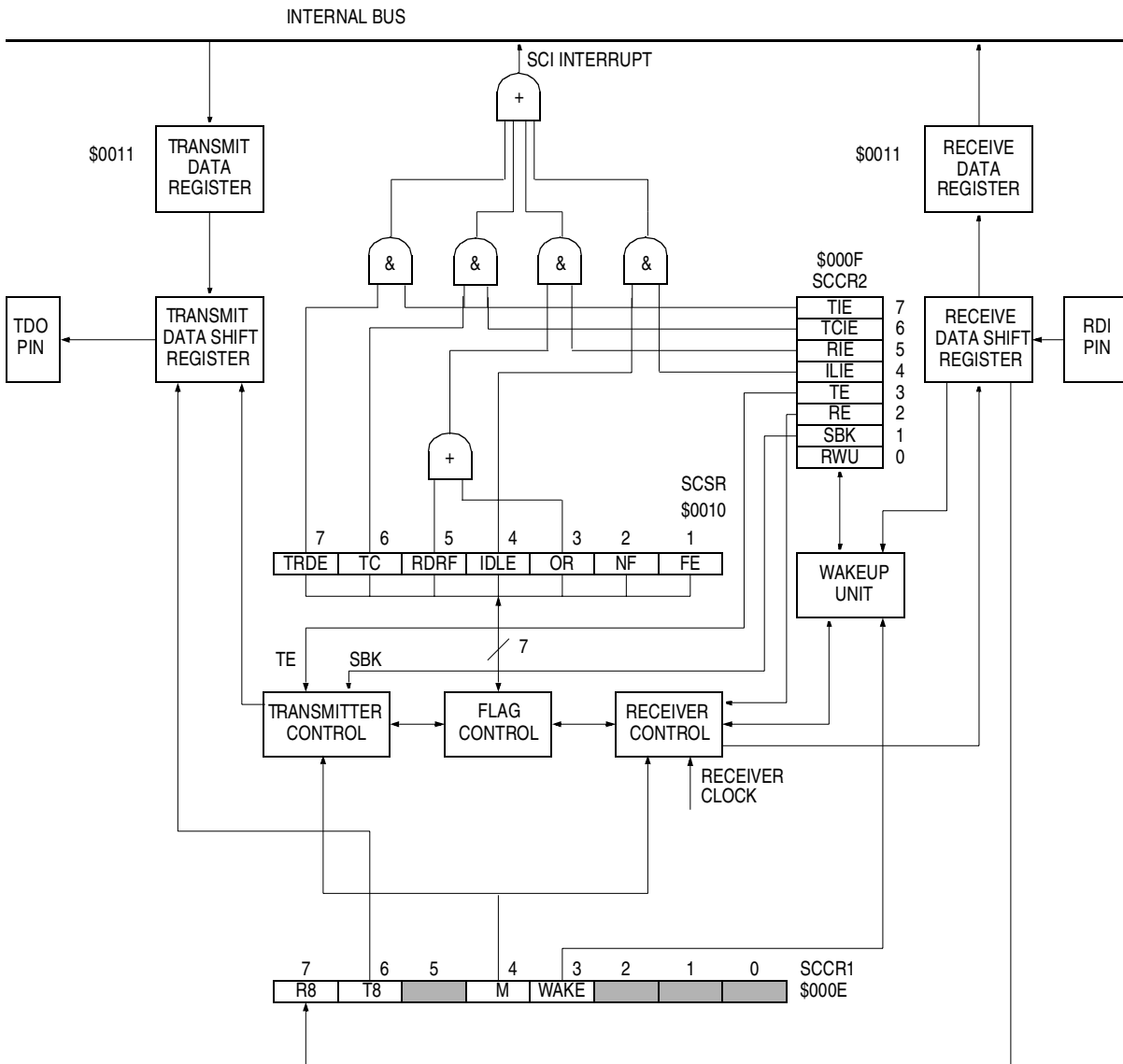

**Figure 9-1. Serial Communications Interface Block Diagram**

**NOTE:** The serial communications data register (SCI SCDR) is controlled by the internal R/W signal. It is the transmit data register when written to and the receive data register when read.

### 9.4 SCI Receiver Features

Features of the SCI receiver include:

- Receiver wakeup function (idle line or address bit)
- Idle line detection
- Framing error detection
- Noise detection
- Overrun detection
- Receiver data register full flag

### 9.5 SCI Transmitter Features

Features of the SCI transmitter include:

- Transmit data register empty flag
- Transmit complete flag
- Send break

### 9.6 Functional Description

A block diagram of the SCI is shown in **Figure 9-1**. Option bits in serial control register1 (SCCR1) select the wakeup method (WAKE bit) and data word length (M bit) of the SCI. SCCR2 provides control bits that individually enable the transmitter and receiver, enable system interrupts, and provide the wakeup enable bit (RWU) and the send break code bit (SBK). Control bits in the baud rate register (BAUD) allow the user to select one of 32 different baud rates for the transmitter and receiver.

Data transmission is initiated by writing to the serial communications data register (SCDR). Provided the transmitter is enabled, data stored in the SCDR is transferred to the transmit data shift register. This transfer of data sets the transmit data register empty flag (TDRE) in the SCI status register (SCSR) and generates an interrupt (if transmitter interrupts are enabled). The transfer of data to the transmit data shift

register is synchronized with the bit rate clock (see **Figure 9-2**). All data is transmitted least significant bit first. Upon completion of data transmission, the transmission complete flag (TC) in the SCSR is set (provided no pending data, preamble, or break is to be sent) and an interrupt is generated (if the transmit complete interrupt is enabled). If the transmitter is disabled, and the data, preamble, or break (in the transmit data shift register) has been sent, the TC bit will be set also. This will also generate an interrupt if the transmission complete interrupt enable bit (TCIE) is set. If the transmitter is disabled during a transmission, the character being transmitted will be completed before the transmitter gives up control of the TDO pin.

When SCDR is read, it contains the last data byte received, provided that the receiver is enabled. The receive data register full flag bit (RDRF) in the SCSR is set to indicate that a data byte has been transferred from the input serial shift register to the SCDR; this will cause an interrupt if the receiver interrupt is enabled. The data transfer from the input serial shift register to the SCDR is synchronized by the receiver bit rate clock. The OR (overrun), NF (noise), or FE (framing) error flags in the SCSR may be set if data reception errors occurred.

An idle line interrupt is generated if the idle line interrupt is enabled and the IDLE bit (which detects idle line transmission) in SCSR is set. This allows a receiver that is not in the wakeup mode to detect the end of a message, or the preamble of a new message, or to re-synchronize with the transmitter. A valid character must be received before the idle line condition or the IDLE bit will not be set and idle line interrupt will not be generated.

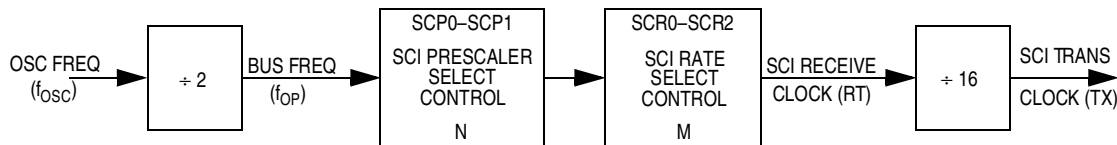
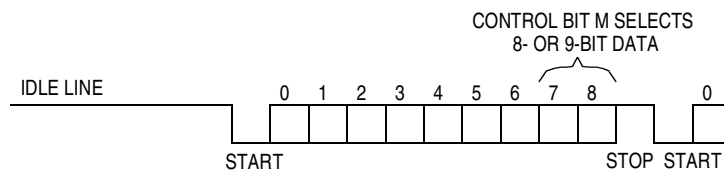

**Figure 9-2. Rate Generator Division**

## 9.7 Data Format

Receive data or transmit data is the serial data that is transferred to the internal data bus from the receive data input pin (RDI) or from the internal bus to the transmit data output pin (TDO). The non-return-to-zero (NRZ) data format shown in **Figure 9-3** is used and must meet these criteria:

- The idle line is brought to a logic 1 state prior to transmission/reception of a character.
- A start bit (logic 0) is used to indicate the start of a frame.
- The data is transmitted and received least significant bit first.
- A stop bit (logic 1) is used to indicate the end of a frame. A frame consists of a start bit, a character of eight or nine data bits, and a stop bit.
- A break is defined as the transmission or reception of a low (logic 0) for at least one complete frame time.



**Figure 9-3. Data Format**

## 9.8 Receiver Wakeup Operation

The receiver logic hardware also supports a receiver wakeup function which is intended for systems having more than one receiver. With this function a transmitting device directs messages to an individual receiver or group of receivers by passing addressing information as the initial byte(s) of each message. The wakeup function allows receivers not addressed to remain in a dormant state for the remainder of the unwanted message. This eliminates any further software overhead to service the remaining characters of the unwanted message and thus improves system performance.

The receiver is placed in wakeup mode by setting the receiver wakeup bit (RWU) in the SCCR2 register. While RWU is set, all of the receiver-related status flags (RDRF, IDLE, OR, NF, and FE) are inhibited (cannot become set).

**NOTE:** *The idle line detect function is inhibited while the RWU bit is set. Although RWU may be cleared by a software write to SCCR2, it would be unusual to do so.*

Normally, RWU is set by software and is cleared automatically in hardware by one of these methods: idle line wakeup or address mark wakeup.

### 9.8.1 Idle Line Wakeup

In idle line wakeup mode, a dormant receiver wakes up as soon as the RDI line becomes idle. Idle is defined as a continuous logic high level on the RDI line for 10 (or 11) full bit times. Systems using this type of wakeup must provide at least one character time of idle between messages to wake up sleeping receivers, but must not allow any idle time between characters within a message.

### 9.8.2 Address Mark Wakeup

In address mark wakeup, the most significant bit (MSB) in a character is used to indicate whether it is an address (logic 1) or data (logic 0) character. Sleeping receivers will wake up whenever an address character is received. Systems using this method for wakeup would set the MSB of the first character of each message and leave it clear for all other characters in the message. Idle periods may be present within messages and no idle time is required between messages for this wakeup method.

## 9.9 Receive Data In (RDI)

Receive data is the serial data that is applied through the input line and the SCI to the internal bus. The receiver circuitry clocks the input at a rate equal to 16 times the baud rate. This time is referred to as the RT rate in **Figure 9-4** and as the receiver clock in **Figure 9-6**.

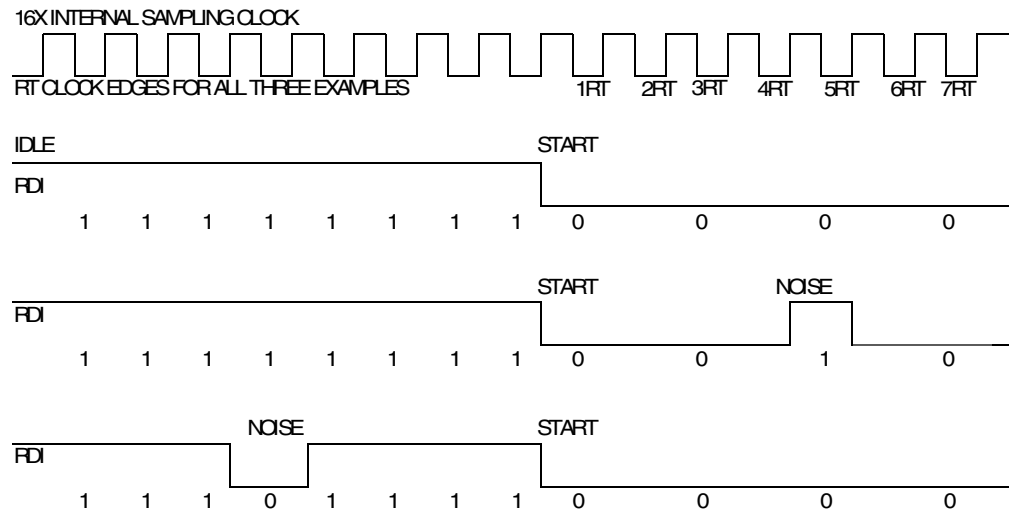

**Figure 9-4. SCI Examples of Start Bit Sampling Techniques**

The receiver clock generator is controlled by the baud rate register; however, the SCI is synchronized by the start bit, independent of the transmitter.

Once a valid start bit is detected, the start bit, each data bit, and the stop bit are sampled three times at RT intervals 8RT, 9RT, and 10RT (1RT is the position where the bit is expected to start), as shown in **Figure 9-5**. The value of the bit is determined by voting logic which takes the value of the majority of the samples. A noise flag is set when all three samples on a valid start bit or data bit or the stop bit do not agree.

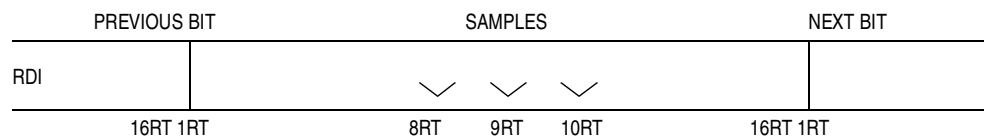

**Figure 9-5. SCI Sampling Technique Used on All Bits**



## 9.10 Start Bit Detection

When the input (idle) line is detected low, it is tested for three more sample times (referred to as the start edge verification samples in **Figure 9-4**). If at least two of these three verification samples detect a logic 0, a valid start bit has been detected; otherwise, the line is assumed to be idle. A noise flag is set if all three verification samples do not detect a logic 0. Thus, a valid start bit could be assumed with a set noise flag present.

If a framing error has occurred without detection of a break (10 0s for 8-bit format or 11 0s for 9-bit format), the circuit continues to operate as if there actually was a stop bit, and the start edge will be placed artificially. The last bit received in the data shift register is inverted to a logic 1, and the three logic 1 start qualifiers (shown in **Figure 9-4**) are forced into the sample shift register during the interval when detection of a start bit is anticipated (see **Figure 9-6**); therefore, the start bit will be accepted no sooner than it is anticipated.

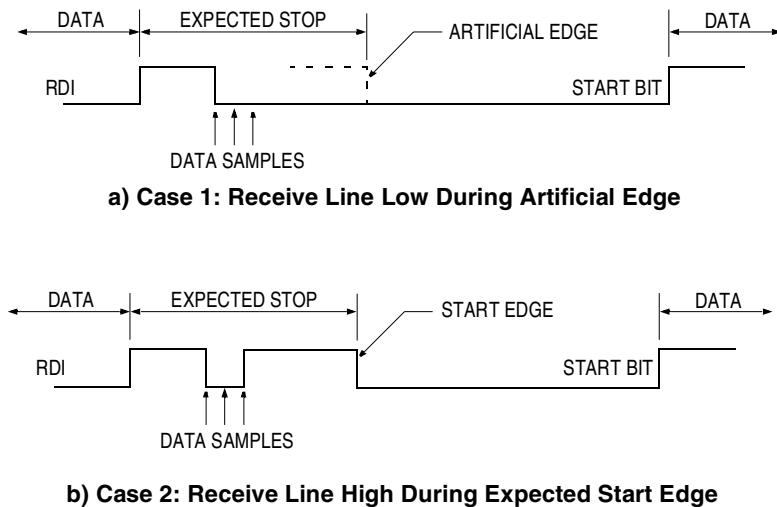

**Figure 9-6. SCI Artificial Start Following a Frame Error**

## Serial Communications Interface (SCI)

If the receiver detects that a break (RDRF = 1, FE = 1, receiver data register = \$003B) produced the framing error, the start bit will not be artificially induced and the receiver must actually detect a logic 1 before the start bit can be recognized (see **Figure 9-7**).

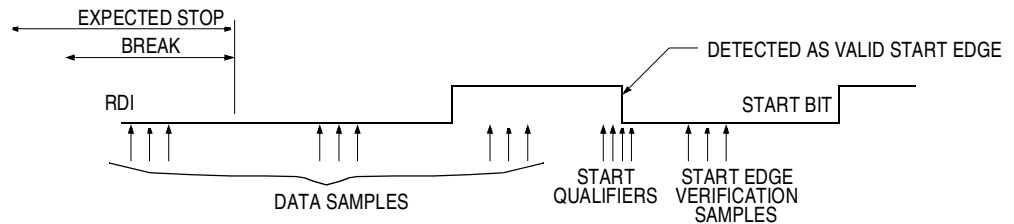

**Figure 9-7. SCI Start Bit Following a Break**

### 9.11 Transmit Data Out (TDO)

Transmit data is the serial data from the internal data bus that is applied through the SCI to the output line. Data format is as discussed in 9.7 Data Format and shown in **Figure 9-3**. The transmitter generates a bit time by using a derivative of the RT clock, thus producing a transmission rate equal to 1/16th that of the receiver sample clock.

### 9.12 SCI I/O Registers

These I/O registers control and monitor SCI operation:

- SCI data register (SCDR)
- SCI control register 1 (SCCR1)
- SCI control register 2 (SCCR2)
- SCI status register (SCSR)

### 9.12.1 SCI Data Register

The SCI data register (SCDR), shown in **Figure 9-8**, is the buffer for characters received and for characters transmitted.

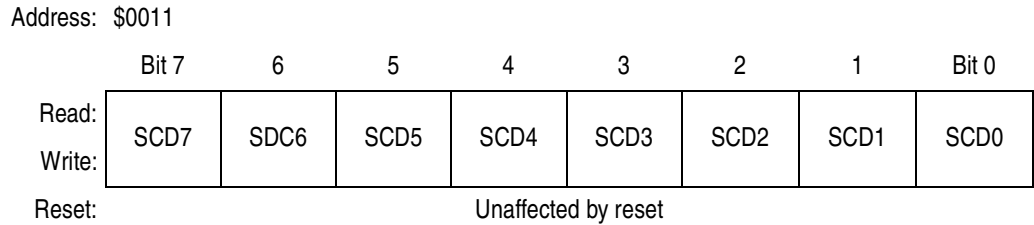
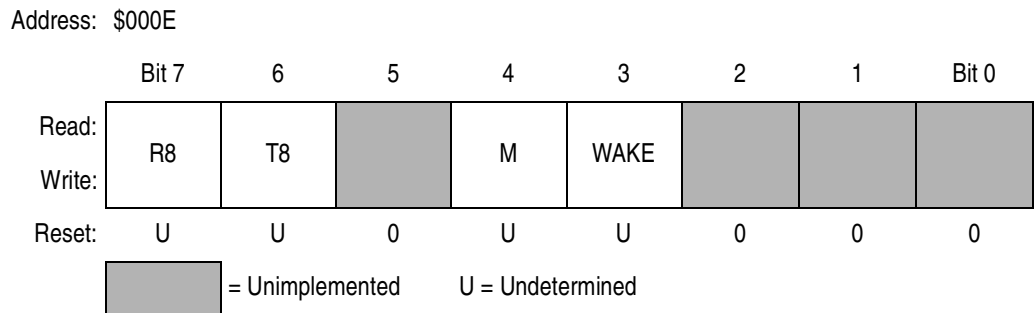

**Figure 9-8. SCI Data Register (SCDR)**

### 9.12.2 SCI Control Register 1

The SCI control register 1 (SCCR1), shown in **Figure 9-9**, has these functions:

- Stores ninth SCI data bit received and ninth SCI data bit transmitted
- Controls SCI character length
- Controls SCI wakeup method



**Figure 9-9. SCI Control Register 1 (SCCR1)**

#### R8 — Bit 8 (Received)

When the SCI is receiving 9-bit characters, R8 is the ninth bit of the received character. R8 receives the ninth bit at the same time that the SCDR receives the other eight bits. Resets have no effect on the R8 bit.

### T8 — Bit 8 (Transmitted)

When the SCI is transmitting 9-bit characters, T8 is the ninth bit of the transmitted character. T8 is loaded into the transmit shift register at the same time that the SCDR is loaded into the transmit register. Resets have no effect on the T8 bit.

### M — Character Length Bit

This read/write bit determines whether SCI characters are 8 bits long or 9 bits long. The ninth bit can be used as an extra stop bit, as a receiver wakeup signal, or as a mark or space parity bit. Resets have no effect on the M bit.

1 = 9-bit SCI characters

0 = 8-bit SCI characters

### WAKE — Wakeup Method Bit

This read/write bit determines which condition wakes up the SCI: a logic 1 (address mark) in the most significant bit (MSB) position of a received character or an idle condition on the PD0/RDI pin. Resets have no effect on the WAKE bit.

1 = Address mark wakeup

0 = Idle line wakeup

### 9.12.3 SCI Control Register 2

SCI control register 2 (SCCR2), shown in **Figure 9-10**, has these functions:

- Enables the SCI receiver and SCI receiver interrupts
- Enables the SCI transmitter and SCI transmitter interrupts
- Enables SCI receiver idle interrupts
- Enables SCI transmission complete interrupts
- Enables SCI wakeup
- Transmits SCI break characters

Address: \$000F

	Bit 7	6	5	4	3	2	1	Bit 0
Read:	TIE	TCIE	RIE	ILIE	TE	RE	RWU	SBK
Write:								
Reset:	0	0	0	0	0	0	0	0

**Figure 9-10. SCI Control Register 2 (SCCR2)**

**TIE — Transmit Interrupt Enable Bit**

This read/write bit enables SCI interrupt requests when the TDRE flag becomes set. Resets clear the TIE bit.

- 1 = TDRE interrupt requests enabled
- 0 = TDRE interrupt requests disabled

**TCIE — Transmission Complete Interrupt Enable Bit**

This read/write bit enables SCI interrupt requests when the TC flag becomes set. Resets clear the TCIE bit.

- 1 = TC interrupt requests enabled
- 0 = TC interrupt requests disabled

**RIE — Receiver Interrupt Enable Bit**

This read/write bit enables SCI interrupt requests when the RDRF flag or the OR flag becomes set. Resets clear the RIE bit.

- 1 = RDRF interrupt requests enabled
- 0 = RDRF interrupt requests disabled

**ILIE — Idle Line Interrupt Enable Bit**

This read/write bit enables SCI interrupt requests when the IDLE bit becomes set. Resets clear the ILIE bit.

- 1 = IDLE interrupt requests enabled
- 0 = IDLE interrupt requests disabled

### TE — Transmitter Enable Bit

Setting this read/write bit begins the transmission by sending a preamble of 10 or 11 logic 1s from the transmit shift register to the PD1/TDO pin. Resets clear the TE bit.

- 1 = Transmission enabled
- 0 = Transmission disabled

### RE — Receiver Enable Bit

Setting this read/write bit enables the receiver. Clearing the RE bit disables the receiver and receiver interrupts but does not affect the receiver interrupt flags. Resets clear the RE bit.

- 1 = Receiver enabled
- 0 = Receiver disabled

### RWU — Receiver Wakeup Enable Bit

This read/write bit puts the receiver in a standby state. Typically, data transmitted to the receiver clears the RWU bit and returns the receiver to normal operation. The WAKE bit in SCCR1 determines whether an idle input or an address mark brings the receiver out of standby state. Reset clears the RWU bit.

- 1 = Standby state
- 0 = Normal operation

### SBK — Send Break Bit

Setting this read/write bit continuously transmits break codes in the form of 10-bit or 11-bit groups of logic 0s. Clearing the SBK bit stops the break codes and transmits a logic 1 as a start bit. Reset clears the SBK bit.

- 1 = Break codes being transmitted
- 0 = No break codes being transmitted

### 9.12.4 SCI Status Register

The SCI status register (SCSR), shown in **Figure 9-11**, contains flags to signal these conditions:

- Transfer of SCDR data to transmit shift register complete
- Transmission complete
- Transfer of receive shift register data SCDR complete
- Receiver input idle
- Noisy data
- Framing error

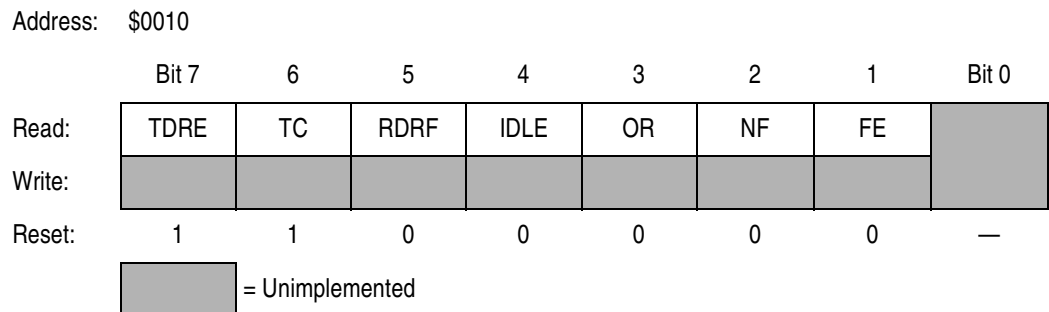

**Figure 9-11. SCI Status Register (SCSR)**

#### TDRE — Transmit Data Register Empty Flag

This clearable, read-only flag is set when the data in the SCDR transfers to the transmit shift register. TDRE generates an interrupt request if the TIE bit in SCCR2 is also set. Clear the TDRE bit by reading the SCSR with TDRE set and then writing to the SCDR. Reset sets the TDRE bit. Software must initialize the TDRE bit to logic 0 to avoid an instant interrupt request when turning the transmitter on.

1 = SCDR data transferred to transmit shift register

0 = SCDR data not transferred to transmit shift register

#### TC — Transmission Complete Flag

This clearable, read-only flag is set when the TDRE bit is set, and no data, preamble, or break character is being transmitted. TDRE generates an interrupt request if the TCIE bit in SCCR2 is also set. Clear the TC bit by reading the SCSR with TC set, and then writing to

the SCDR. Reset sets the TC bit. Software must initialize the TC bit to logic 0 to avoid an instant interrupt request when turning the transmitter on.

1 = No transmission in progress

0 = Transmission in progress

### RDRF — Receive Data Register Full Flag

This clearable, read-only flag is set when the data in the receive shift register transfers to the SCI data register. RDRF generates an interrupt request if the RIE bit in the SCCR2 is also set. Clear the RDRF bit by reading the SCSR with RDRF set and then reading the SCDR.

1 = Received data available in SCDR

0 = Received data not available in SCDR

### IDLE — Receiver Idle Flag

This clearable, read-only flag is set when 10 or 11 consecutive logic 1s appear on the receiver input. IDLE generates an interrupt request if the ILIE bit in the SCCR2 is also set. Clear the ILIE bit by reading the SCSR with IDLE set and then reading the SCDR.

1 = Receiver input idle

0 = Receiver input not idle

### OR — Receiver Overrun Flag

This clearable, read-only flag is set if the SCDR is not read before the receive shift register receives the next word. OR generates an interrupt request if the RIE bit in the SCCR2 is also set. The data in the shift register is lost, but the data already in the SCDR is not affected. Clear the OR bit by reading the SCSR with OR set and then reading the SCDR.

1 = Receive shift register full and RDRF = 1

0 = No receiver overrun

### NF — Receiver Noise Flag

This clearable, read-only flag is set when noise is detected in data received in the SCI data register. Clear the NF bit by reading the SCSR and then reading the SCDR.

1 = Noise detected in SCDR

0 = No noise detected in SCDR



### FE — Receiver Framing Error Flag

This clearable, read-only flag is set when there is a logic 0 where a stop bit should be in the character shifted into the receive shift register. If the received word causes both a framing error and an overrun error, the OR flag is set and the FE flag is not set. Clear the FE bit by reading the SCSR and then reading the SCDR.

- 1 = Framing error
- 0 = No framing error

### 9.12.5 Baud Rate Register

The baud rate register (BAUD), shown in **Figure 9-12**, selects the baud rate for both the receiver and the transmitter.

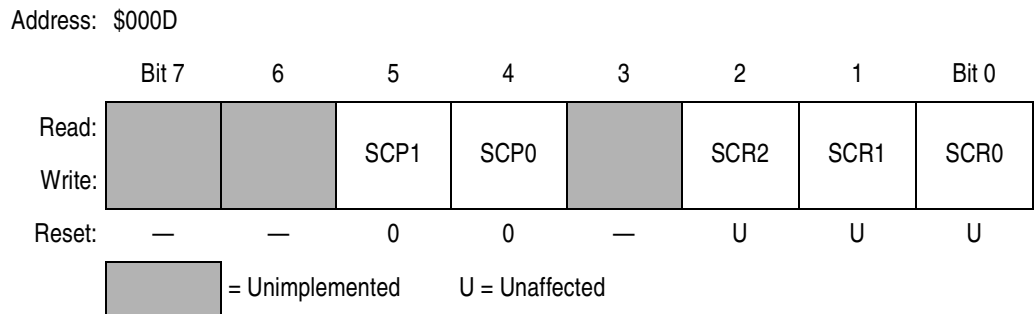

**Figure 9-12. Baud Rate Register (BAUD)**

### SCP1 — SCP0—SCI Prescaler Select Bits

These read/write bits control prescaling of the baud rate generator clock, as shown in **Table 9-1**. Reset clears both SCP1 and SCP0.

**Table 9-1. Baud Rate Generator Clock Prescaling**

SCP1 and SCP0	Baud Rate Generator Clock
0 0	Internal clock ÷ 1
0 1	Internal clock ÷ 3
1 0	Internal clock ÷ 4
1 1	Internal clock ÷ 13

## Serial Communications Interface (SCI)

### SCR2 — SCR0—SCI Baud Rate Select Bits

These read/write bits select the SCI baud rate, as shown in **Table 9-2**. Resets have no effect on the SCR2–SCR0 bits.

**Table 9-2. Baud Rate Selection**

SCR2, SCR1, and SCR0	SCI Baud Rate (Baud)
0 0 0	Prescaled clock ÷ 1
0 0 1	Prescaled clock ÷ 2
0 1 0	Prescaled clock ÷ 4
0 1 1	Prescaled clock ÷ 8
1 0 0	Prescaled clock ÷ 16
1 0 1	Prescaled clock ÷ 32
1 1 0	Prescaled clock ÷ 64
1 1 1	Prescaled clock ÷ 128

## Section 10. Serial Peripheral Interface (SPI)

### 10.1 Content

10.2	Introduction . . . . .	91
10.3	Features . . . . .	92
10.4	SPI Signal Description . . . . .	92
10.4.1	Master In Slave Out (MISO) . . . . .	93
10.4.2	Master Out Slave In (MOSI) . . . . .	93
10.4.3	Serial Clock (SCK) . . . . .	94
10.4.4	Slave Select (SS) . . . . .	94
10.5	Functional Description . . . . .	95
10.6	SPI Registers . . . . .	97
10.6.1	Serial Peripheral Control Register . . . . .	97
10.6.2	Serial Peripheral Status Register . . . . .	99
10.6.3	Serial Peripheral Data I/O Register . . . . .	101

### 10.2 Introduction

The serial peripheral interface (SPI) is an interface built into the device which allows several M68HC05 microcontroller units (MCU), or M68HC05 MCU plus peripheral devices, to be interconnected within a single printed circuit board. In an SPI, separate wires are required for data and clock. In the SPI format, the clock is not included in the data stream and must be furnished as a separate signal. An SPI system may be configured in one containing one master MCU and several slave MCUs or in a system in which an MCU is capable of being a master or a slave.

### 10.3 Features

SPI features include:

- Full-duplex, 4-wire synchronous transfers
- Master or slave operation
- Bus frequency divided by 2 (maximum) master bit frequency
- Bus frequency (maximum) slave bit frequency
- Four programmable master bit rates
- Programmable clock polarity and phase
- End-of-transmission interrupt flag
- Write collision flag protection
- Master-master mode fault protection capability

### 10.4 SPI Signal Description

The four basic signals (MOSI, MISO, SCK, and  $\overline{SS}$ ) are described here. Each signal function is described for both the master and slave modes.

**NOTE:** *Any SPI output line has to have its corresponding data direction register bit set. If this bit is clear, the line is disconnected from the SPI logic and becomes a general-purpose input line. When the SPI is enabled, any SPI input line is forced to act as an input regardless of what is in the corresponding data direction register bit.*

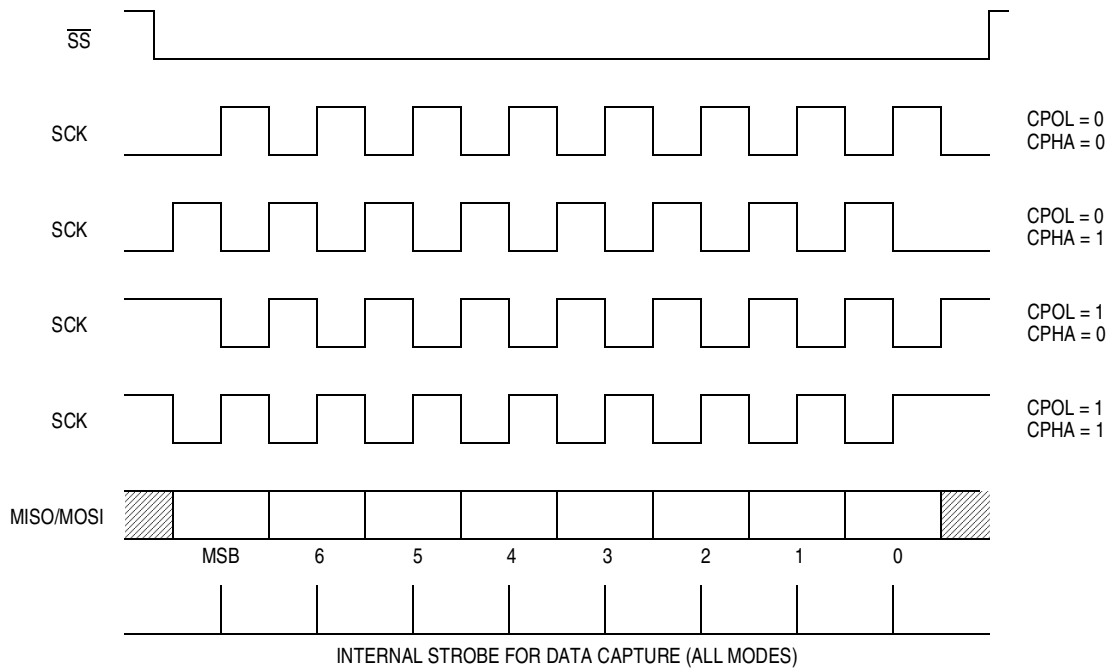

**Figure 10-1. Data Clock Timing Diagram**

### 10.4.1 Master In/Slave Out (MISO)

The MISO line is configured as an input in a master device and as an output in a slave device. It is one of the two lines that transfer serial data in one direction, with the most significant bit sent first. The MISO line of a slave device is placed in the high-impedance state if the slave is not selected.

### 10.4.2 Master Out/Slave In (MOSI)

The MOSI line is configured as an output in a master device and as an input in a slave device. It is one of the two lines that transfer serial data in one direction with the most significant bit sent first.

### 10.4.3 Serial Clock (SCK)

The master clock is used to synchronize data movement both in and out of the device through its MOSI and MISO lines. The master and slave devices are capable of exchanging a byte of information during a sequence of eight clock cycles. Since SCK is generated by the master device, this line becomes an input on a slave device.

As shown in **Figure 10-1**, four possible timing relationships may be chosen by using control bits CPOL and CPHA in the serial peripheral control register (SPCR). Both master and slave devices must operate with the same timing. The master device always places data on the MOSI line a half cycle before the clock edge (SCK), in order for the slave device to latch the data.

Two bits (SPR0 and SPR1) in the SPCR of the master device select the clock rate. In a slave device, SPR0 and SPR1 have no effect on the operation of the SPI.

### 10.4.4 Slave Select ( $\overline{SS}$ )

The slave select ( $\overline{SS}$ ) input line is used to select a slave device. It has to be low prior to data transactions and must stay low for the duration of the transaction. The  $\overline{SS}$  line on the master must be tied high. In master mode, if the  $\overline{SS}$  pin is pulled low during a transmission, a mode fault error flag (MODF) is set in the SPSR. In master mode the  $\overline{SS}$  pin can be selected as a general-purpose output by writing a 1 in bit 5 of the port D data direction register, thus disabling the mode fault circuit.

When CPHA = 0, the shift clock is the OR of  $\overline{SS}$  with SCK. In this clock phase mode,  $\overline{SS}$  must go high between successive characters in an SPI message. When CPHA = 1,  $\overline{SS}$  may be left low for several SPI characters. In cases where there is only one SPI slave MCU, its  $\overline{SS}$  line could be tied to  $V_{SS}$  as long as CPHA = 1 clock modes are used.

## 10.5 Functional Description

**Figure 10-2** shows a block diagram of the serial peripheral interface circuitry. When a master device transmits data to a slave via the MOSI line, the slave device responds by sending data to the master device via the master's MISO line. This implies full duplex transmission with both data out and data in synchronized with the same clock signal. Thus, the byte transmitted is replaced by the byte received and eliminates the need for separate transmit-empty and receive-full status bits. A single status bit (SPIF) is used to signify that the input/output (I/O) operation has been completed.

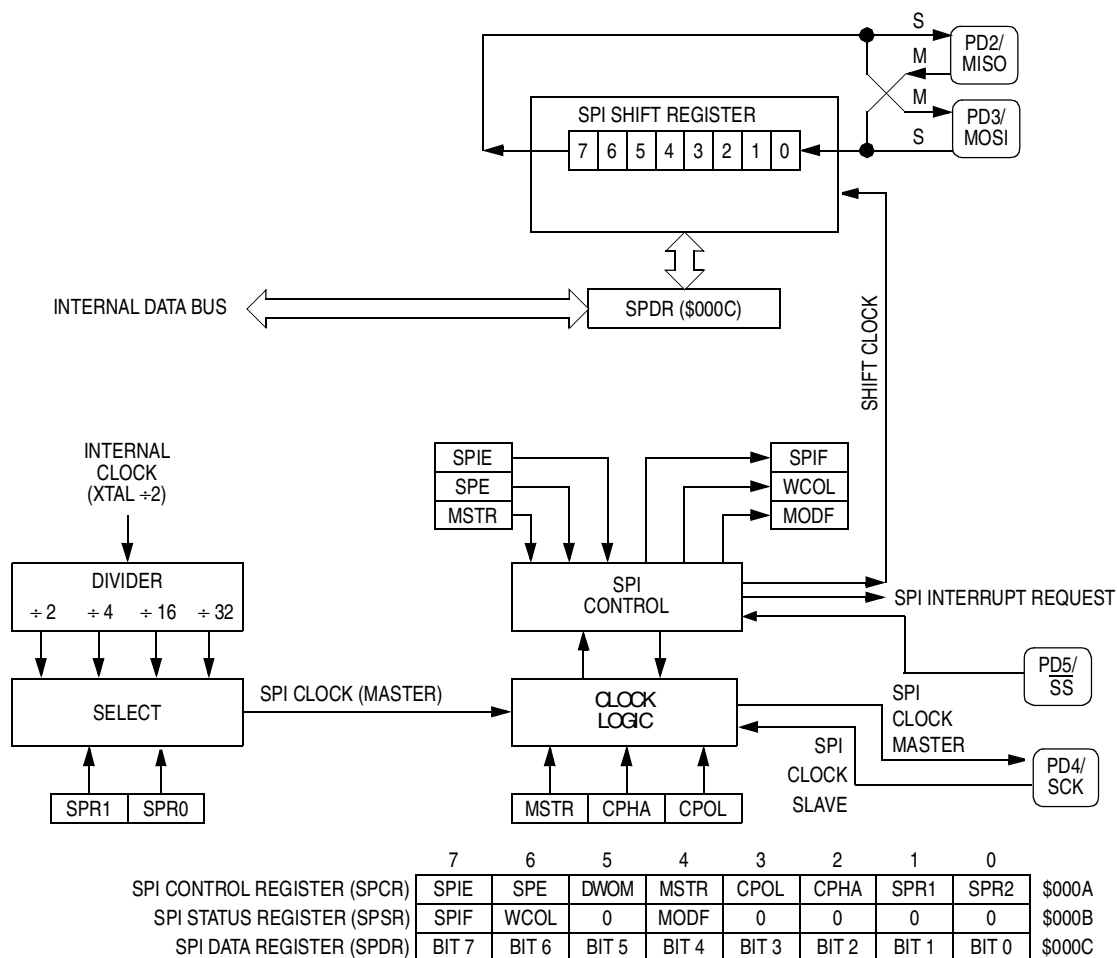

**Figure 10-2. Serial Peripheral Interface Block Diagram**

## Serial Peripheral Interface (SPI)

The SPI is double buffered on read, but not on write. If a write is performed during data transfer, the transfer occurs uninterrupted, and the write will be unsuccessful. This condition will cause the write collision (WCOL) status bit in the SPSR to be set. After a data byte is shifted, the SPIF flag of the SPSR is set.

In the master mode, the SCK pin is an output. It idles high or low, depending on the CPOL bit in the SPCR, until data is written to the shift register, at which point eight clocks are generated to shift the eight bits of data and then SCK goes idle again.

In a slave mode, the slave select start logic receives a logic low at the  $\overline{SS}$  pin and a clock at the SCK pin. Thus, the slave is synchronized with the master. Data from the master is received serially at the MOSI line and loads the 8-bit shift register. After the 8-bit shift register is loaded, its data is parallel transferred to the read buffer. During a write cycle, data is written into the shift register, then the slave waits for a clock train from the master to shift the data out on the slave's MISO line.

**Figure 10-3** illustrates the MOSI, MISO, SCK, and  $\overline{SS}$  master-slave interconnections.

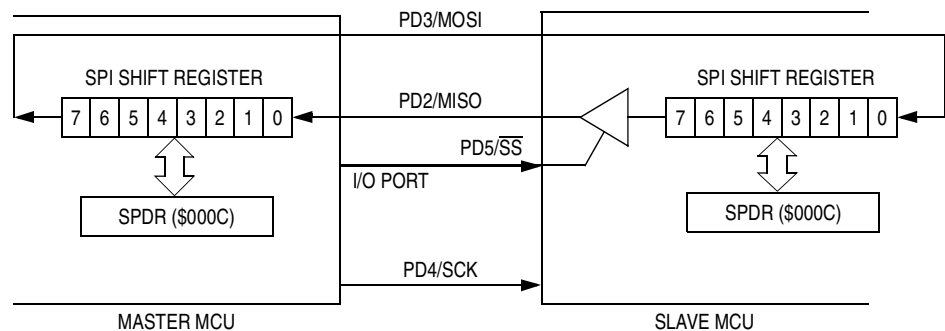

**Figure 10-3. Serial Peripheral Interface  
Master-Slave Interconnection**



## 10.6 SPI Registers

This subsection describes the three registers in the SPI which provide control, status, and data storage functions. These registers are:

- Serial peripheral control register (SPCR)
- Serial peripheral status register (SPSR)
- Serial peripheral data I/O register (SPDR)

### 10.6.1 Serial Peripheral Control Register

The SPI control register (SPCR), shown in **Figure 10-4**, controls these functions:

- Enables SPI interrupts
- Enables the SPI system
- Selects between standard CMOS or open drain outputs for port D
- Selects between master mode and slave mode
- Controls the clock/data relationship between master and slave
- Determines the idle level of the clock pin

Address: \$000A

	Bit 7	6	5	4	3	2	1	Bit 0
Read:	SPIE	SPE	DWOM	MSTR	CPOL	CPHA	SPR1	SPR0
Write:								
Reset:	0	0	0	0	0	1	U	U

U = Undetermined

**Figure 10-4. SPI Control Register (SPCR)**

#### SPIE — Serial Peripheral Interrupt Enable Bit

This read/write bit enables SPI interrupts. Reset clears the SPIE bit.

- 1 = SPI interrupts enabled
- 0 = SPI interrupts disabled

### SPE — Serial Peripheral System Enable Bit

This read/write bit enables the SPI. Reset clears the SPE bit.

- 1 = SPI system enabled
- 0 = SPI system disabled

### DWOM — Port D Wire-OR Mode Option Bit

This read/write bit disables the high side driver transistors on port D outputs so that port D outputs become open-drain drivers. DWOM affects all seven port D pins together.

- 1 = Port D outputs act as open-drain outputs.
- 0 = Port D outputs are normal CMOS outputs.

### MSTR — Master Mode Select Bit

This read/write bit selects master mode operation or slave mode operation. Reset clears the MSTR bit.

- 1 = Master mode
- 0 = Slave mode

### CPOL — Clock Polarity Bit

When the clock polarity bit is cleared and data is not being transferred, a steady state low value is produced at the SCK pin of the master device. Conversely, if this bit is set, the SCK pin will idle high. This bit is also used in conjunction with the clock phase control bit to produce the desired clock-data relationship between master and slave. See **Figure 10-1**.

### CPHA — Clock Phase Bit

The clock phase bit, in conjunction with the CPOL bit, controls the clock-data relationship between master and slave. The CPOL bit can be thought of as simply inserting an inverter in series with the SCK line. The CPHA bit selects one of two fundamentally different clocking protocols. When CPHA = 0, the shift clock is the OR of SCK with  $\overline{SS}$ . As soon as  $\overline{SS}$  goes low, the transaction begins and the first edge on SCK invokes the first data sample. When CPHA=1, the  $\overline{SS}$  pin may be thought of as a simple output enable control. See **Figure 10-1**.

### SPR1 and SPR0 — SPI Clock Rate Select Bits

These read/write bits select one of four master mode serial clock rates, as shown in **Table 10-1**. They have no effect in slave mode.

**Table 10-1. SPI Clock Rate Selection**

SPR1 and SPR0	SPI Clock Rate
0 0	Internal clock ÷ 2
0 1	Internal clock ÷ 4
1 0	Internal clock ÷ 16
1 1	Internal clock ÷ 32

### 10.6.2 Serial Peripheral Status Register

The SPI status register (SPSR), shown in **Figure 10-5**, contains flags to signal these conditions:

- SPI transmission complete
- Write collision
- Mode fault

Address: \$000B

	Bit 7	6	5	4	3	2	1	Bit 0
Read:	SPIF	WCOL	0	MODF	0	0	0	0
Write:								
Reset:	0	0	0	0	0	0	0	0

 = Unimplemented

**Figure 10-5. SPI Status Register**

#### SPIF — SPI Transfer Complete Flag

The serial peripheral data transfer flag bit is set upon completion of data transfer between the processor and external device. If SPIF goes high, and if SPIE is set, a serial peripheral interrupt is generated. Clearing the SPIF bit is accomplished by reading the SPSR (with

SPIF set) followed by an access of the SPDR. Following the initial transfer, unless SPSR is read (with SPIF set) first, attempts to write to SPDR are inhibited.

### WCOL — Write Collision Bit

The write collision bit is set when an attempt is made to write to the serial peripheral data register while data transfer is taking place. If CPHA is 0, a transfer is said to begin when  $\overline{SS}$  goes low and the transfer ends when  $\overline{SS}$  goes high after eight clock cycles on SCK. When CPHA is 1, a transfer is said to begin the first time SCK becomes active while  $\overline{SS}$  is low and the transfer ends when the SPIF flag gets set. Clearing the WCOL bit is accomplished by reading the SPSR (with WCOL set) followed by an access to SPDR.

### MODF — Mode Fault Flag

The mode fault flag indicates that there may have been a multi-master conflict for system control and allows a proper exit from system operation to a reset or default system state. The MODF bit is normally clear, and is set only when the master device has its  $\overline{SS}$  pin pulled low. Setting the MODF bit affects the internal serial peripheral interface system in these ways:

1. An SPI interrupt is generated if SPIE = 1.
2. The SPE bit is cleared. This disables the SPI.
3. The MSTR bit is cleared, thus forcing the device into the slave mode.

Clearing the MODF bit is accomplished by reading the SPSR (with MODF set), followed by a write to the SPCR. Control bits SPE and MSTR may be restored by user software to their original state during this clearing sequence or after the MODF bit has been cleared. It is also necessary to restore DDRD after a mode fault.

### Bits 5 and 3–0 — Not Implemented

These bits always read 0.

### 10.6.3 Serial Peripheral Data I/O Register

The serial peripheral data I/O register (SPDR), shown in **Figure 10-6**, is used to transmit and receive data on the serial bus. Only a write to this register will initiate transmission/reception of another byte and this will only occur in the master device. At the completion of transmitting a byte of data, the SPIF status bit is set in both the master and slave devices.

When the user reads the serial peripheral data I/O register, a buffer is actually being read. The first SPIF must be cleared by the time a second transfer of the data from the shift register to the read buffer is initiated or an overrun condition will exist. In cases of overrun, the byte which causes the overrun is lost.

A write to the serial peripheral data I/O register is not buffered and places data directly into the shift register for transmission.

Address: \$000C

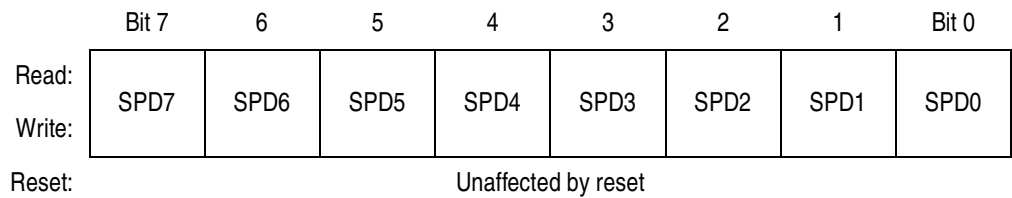

**Figure 10-6. SPI Data Register (SPDR)**



## Section 11. Instruction Set

### 11.1 Contents

11.2	Introduction . . . . .	103
11.3	Addressing Modes . . . . .	104
11.3.1	Inherent . . . . .	104
11.3.2	Immediate . . . . .	104
11.3.3	Direct . . . . .	105
11.3.4	Extended . . . . .	105
11.3.5	Indexed, No Offset . . . . .	105
11.3.6	Indexed, 8-Bit Offset . . . . .	105
11.3.7	Indexed, 16-Bit Offset . . . . .	106
11.3.8	Relative . . . . .	106
11.4	Instruction Types . . . . .	107
11.4.1	Register/Memory Instructions . . . . .	107
11.4.2	Read-Modify-Write Instructions . . . . .	108
11.4.3	Jump/Branch Instructions . . . . .	109
11.4.4	Bit Manipulation Instructions . . . . .	111
11.4.5	Control Instructions . . . . .	111
11.5	Instruction Set Summary . . . . .	112
11.6	Opcode Map . . . . .	118

### 11.2 Introduction

The microcontroller unit (MCU) instruction set has 62 instructions and uses eight addressing modes. The instructions include all those of the M146805 CMOS (complementary metal-oxide semiconductor) Family plus one more: the unsigned multiply (MUL) instruction. The MUL instruction allows unsigned multiplication of the contents of the accumulator (A) and the index register (X). The high-order product is stored in the index register, and the low-order product is stored in the accumulator.

## 11.3 Addressing Modes

The central processor unit (CPU) uses eight addressing modes for flexibility in accessing data. The addressing modes provide eight different ways for the CPU to find the data required to execute an instruction. The eight addressing modes are:

- Inherent
- Immediate
- Direct
- Extended
- Indexed, no offset
- Indexed, 8-bit offset
- Indexed, 16-bit offset
- Relative

### 11.3.1 Inherent

Inherent instructions are those that have no operand, such as return from interrupt (RTI) and stop (STOP). Some of the inherent instructions act on data in the CPU registers, such as set carry flag (SEC) and increment accumulator (INCA). Inherent instructions require no operand address and are one byte long.

### 11.3.2 Immediate

Immediate instructions are those that contain a value to be used in an operation with the value in the accumulator or index register. Immediate instructions require no operand address and are two bytes long. The opcode is the first byte, and the immediate data value is the second byte.



### 11.3.3 Direct

Direct instructions can access any of the first 256 memory locations with two bytes. The first byte is the opcode, and the second is the low byte of the operand address. In direct addressing, the CPU automatically uses \$00 as the high byte of the operand address.

### 11.3.4 Extended

Extended instructions use three bytes and can access any address in memory. The first byte is the opcode; the second and third bytes are the high and low bytes of the operand address.

When using the Motorola assembler, the programmer does not need to specify whether an instruction is direct or extended. The assembler automatically selects the shortest form of the instruction.

### 11.3.5 Indexed, No Offset

Indexed instructions with no offset are 1-byte instructions that can access data with variable addresses within the first 256 memory locations. The index register contains the low byte of the effective address of the operand. The CPU automatically uses \$00 as the high byte, so these instructions can address locations \$0000–\$00FF.

Indexed, no offset instructions are often used to move a pointer through a table or to hold the address of a frequently used random-access memory (RAM) or input/output (I/O) location.

### 11.3.6 Indexed, 8-Bit Offset

Indexed, 8-bit offset instructions are 2-byte instructions that can access data with variable addresses within the first 511 memory locations. The CPU adds the unsigned byte in the index register to the unsigned byte following the opcode. The sum is the effective address of the operand. These instructions can access locations \$0000–\$01FE.

Indexed 8-bit offset instructions are useful for selecting the *k*th element in an *n*-element table. The table can begin anywhere within the first 256 memory locations and could extend as far as location 510 (\$01FE). The *k* value is typically in the index register, and the address of the beginning of the table is in the byte following the opcode.

### 11.3.7 Indexed, 16-Bit Offset

Indexed, 16-bit offset instructions are 3-byte instructions that can access data with variable addresses at any location in memory. The CPU adds the unsigned byte in the index register to the two unsigned bytes following the opcode. The sum is the effective address of the operand. The first byte after the opcode is the high byte of the 16-bit offset; the second byte is the low byte of the offset.

Indexed, 16-bit offset instructions are useful for selecting the *k*th element in an *n*-element table anywhere in memory.

As with direct and extended addressing, the Motorola assembler determines the shortest form of indexed addressing.

### 11.3.8 Relative

Relative addressing is only for branch instructions. If the branch condition is true, the CPU finds the effective branch destination by adding the signed byte following the opcode to the contents of the program counter. If the branch condition is not true, the CPU goes to the next instruction. The offset is a signed, two's complement byte that gives a branching range of  $-128$  to  $+127$  bytes from the address of the next location after the branch instruction.

When using the Motorola assembler, the programmer does not need to calculate the offset, because the assembler determines the proper offset and verifies that it is within the span of the branch.

## 11.4 Instruction Types

The MCU instructions fall into these five categories:

- Register/memory instructions
- Read-modify-write instructions
- Jump/branch instructions
- Bit manipulation instructions
- Control instructions

### 11.4.1 Register/Memory Instructions

These instructions operate on central processor unit (CPU) registers and memory locations. Most of them use two operands. One operand is in either the accumulator or the index register. The CPU finds the other operand in memory.

**Table 11-1. Register/Memory Instructions**

Instruction	Mnemonic
Add Memory Byte and Carry Bit to Accumulator	ADC
Add Memory Byte to Accumulator	ADD
AND Memory Byte with Accumulator	AND
Bit Test Accumulator	BIT
Compare Accumulator	CMP
Compare Index Register with Memory Byte	CPX
EXCLUSIVE OR Accumulator with Memory Byte	EOR
Load Accumulator with Memory Byte	LDA
Load Index Register with Memory Byte	LDX
Multiply	MUL
OR Accumulator with Memory Byte	ORA
Subtract Memory Byte and Carry Bit from Accumulator	SBC
Store Accumulator in Memory	STA
Store Index Register in Memory	STX
Subtract Memory Byte from Accumulator	SUB

## 11.4.2 Read-Modify-Write Instructions

These instructions read a memory location or a register, modify its contents, and write the modified value back to the memory location or to the register.

**NOTE:** *Do not use read-modify-write operations on write-only registers.*

**Table 11-2. Read-Modify-Write Instructions**

Instruction	Mnemonic
Arithmetic Shift Left (Same as LSL)	ASL
Arithmetic Shift Right	ASR
Bit Clear	BCLR <sup>(1)</sup>
Bit Set	BSET <sup>(1)</sup>
Clear Register	CLR
Complement (One's Complement)	COM
Decrement	DEC
Increment	INC
Logical Shift Left (Same as ASL)	LSL
Logical Shift Right	LSR
Negate (Two's Complement)	NEG
Rotate Left through Carry Bit	ROL
Rotate Right through Carry Bit	ROR
Test for Negative or Zero	TST <sup>(2)</sup>

1. Unlike other read-modify-write instructions, BCLR and BSET use only direct addressing.
2. TST is an exception to the read-modify-write sequence because it does not write a replacement value.

### 11.4.3 Jump/Branch Instructions

Jump instructions allow the CPU to interrupt the normal sequence of the program counter. The unconditional jump instruction (JMP) and the jump-to-subroutine instruction (JSR) have no register operand. Branch instructions allow the CPU to interrupt the normal sequence of the program counter when a test condition is met. If the test condition is not met, the branch is not performed.

The BRCLR and BRSET instructions cause a branch based on the state of any readable bit in the first 256 memory locations. These 3-byte instructions use a combination of direct addressing and relative addressing. The direct address of the byte to be tested is in the byte following the opcode. The third byte is the signed offset byte. The CPU finds the effective branch destination by adding the third byte to the program counter if the specified bit tests true. The bit to be tested and its condition (set or clear) is part of the opcode. The span of branching is from  $-128$  to  $+127$  from the address of the next location after the branch instruction. The CPU also transfers the tested bit to the carry/borrow bit of the condition code register.

**Table 11-3. Jump and Branch Instructions**

Instruction	Mnemonic
Branch if Carry Bit Clear	BCC
Branch if Carry Bit Set	BCS
Branch if Equal	BEQ
Branch if Half-Carry Bit Clear	BHCC
Branch if Half-Carry Bit Set	BHCS
Branch if Higher	BHI
Branch if Higher or Same	BHS
Branch if $\overline{\text{IRQ}}$ Pin High	BIH
Branch if $\overline{\text{IRQ}}$ Pin Low	BIL
Branch if Lower	BLO
Branch if Lower or Same	BLS
Branch if Interrupt Mask Clear	BMC
Branch if Minus	BMI
Branch if Interrupt Mask Set	BMS
Branch if Not Equal	BNE
Branch if Plus	BPL
Branch Always	BRA
Branch if Bit Clear	BRCLR
Branch Never	BRN
Branch if Bit Set	BRSET
Branch to Subroutine	BSR
Unconditional Jump	JMP
Jump to Subroutine	JSR

#### 11.4.4 Bit Manipulation Instructions

The CPU can set or clear any writable bit in the first 256 bytes of memory, which includes I/O registers and on-chip RAM locations. The CPU can also test and branch based on the state of any bit in any of the first 256 memory locations.

**Table 11-4. Bit Manipulation Instructions**

Instruction	Mnemonic
Bit Clear	BCLR
Branch if Bit Clear	BRCLR
Branch if Bit Set	BRSET
Bit Set	BSET

#### 11.4.5 Control Instructions

These instructions act on CPU registers and control CPU operation during program execution.

**Table 11-5. Control Instructions**

Instruction	Mnemonic
Clear Carry Bit	CLC
Clear Interrupt Mask	CLI
No Operation	NOP
Reset Stack Pointer	RSP
Return from Interrupt	RTI
Return from Subroutine	RTS
Set Carry Bit	SEC
Set Interrupt Mask	SEI
Stop Oscillator and Enable IRQ Pin	STOP
Software Interrupt	SWI
Transfer Accumulator to Index Register	TAX
Transfer Index Register to Accumulator	TXA
Stop CPU Clock and Enable Interrupts	WAIT

## 11.5 Instruction Set Summary

Table 11-6. Instruction Set Summary (Sheet 1 of 7)

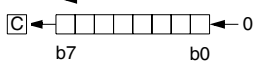
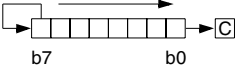
Source Form	Operation	Description	Effect on CCR					Address Mode	Opcode	Operand	Cycles
			H	I	N	Z	C				
ADC #opr ADC opr ADC opr ADC opr,X ADC opr,X ADC ,X	Add with Carry	$A \leftarrow (A) + (M) + (C)$	↑	—	↑	↑	↑	IMM DIR EXT IX2 IX1 IX	A9 B9 C9 D9 E9 F9	ii dd hh ll ee ff ff	2 3 4 5 4 3
ADD #opr ADD opr ADD opr ADD opr,X ADD opr,X ADD ,X	Add without Carry	$A \leftarrow (A) + (M)$	↑	—	↑	↑	↑	IMM DIR EXT IX2 IX1 IX	AB BB CB DB EB FB	ii dd hh ll ee ff ff	2 3 4 5 4 3
AND #opr AND opr AND opr AND opr,X AND opr,X AND ,X	Logical AND	$A \leftarrow (A) \wedge (M)$	—	—	↑	↑	—	IMM DIR EXT IX2 IX1 IX	A4 B4 C4 D4 E4 F4	ii dd hh ll ee ff ff	2 3 4 5 4 3
ASL opr ASLA ASLX ASL opr,X ASL ,X	Arithmetic Shift Left (Same as LSL)		—	—	↑	↑	↑	DIR INH INH IX1 IX	38 48 58 68 78	dd ff	5 3 3 6 5
ASR opr ASRA ASRX ASR opr,X ASR ,X	Arithmetic Shift Right		—	—	↑	↑	↑	DIR INH INH IX1 IX	37 47 57 67 77	dd ff	5 3 3 6 5
BCC rel	Branch if Carry Bit Clear	$PC \leftarrow (PC) + 2 + rel? C = 0$	—	—	—	—	—	REL	24	rr	3
BCLR n opr	Clear Bit n	$M_n \leftarrow 0$	—	—	—	—	—	DIR (b0) DIR (b1) DIR (b2) DIR (b3) DIR (b4) DIR (b5) DIR (b6) DIR (b7)	11 13 15 17 19 1B 1D 1F	dd dd dd dd dd dd dd dd	5 5 5 5 5 5 5 5
BCS rel	Branch if Carry Bit Set (Same as BLO)	$PC \leftarrow (PC) + 2 + rel? C = 1$	—	—	—	—	—	REL	25	rr	3
BEQ rel	Branch if Equal	$PC \leftarrow (PC) + 2 + rel? Z = 1$	—	—	—	—	—	REL	27	rr	3



**Table 11-6. Instruction Set Summary (Sheet 2 of 7)**

Source Form	Operation	Description	Effect on CCR					Address Mode	Opcode	Operand	Cycles
			H	I	N	Z	C				
BHCC <i>rel</i>	Branch if Half-Carry Bit Clear	$PC \leftarrow (PC) + 2 + rel ? H = 0$	—	—	—	—	—	REL	28	rr	3
BHCS <i>rel</i>	Branch if Half-Carry Bit Set	$PC \leftarrow (PC) + 2 + rel ? H = 1$	—	—	—	—	—	REL	29	rr	3
BHI <i>rel</i>	Branch if Higher	$PC \leftarrow (PC) + 2 + rel ? C \vee Z = 0$	—	—	—	—	—	REL	22	rr	3
BHS <i>rel</i>	Branch if Higher or Same	$PC \leftarrow (PC) + 2 + rel ? C = 0$	—	—	—	—	—	REL	24	rr	3
BIH <i>rel</i>	Branch if $\overline{IRQ}$ Pin High	$PC \leftarrow (PC) + 2 + rel ? \overline{IRQ} = 1$	—	—	—	—	—	REL	2F	rr	3
BIL <i>rel</i>	Branch if $\overline{IRQ}$ Pin Low	$PC \leftarrow (PC) + 2 + rel ? \overline{IRQ} = 0$	—	—	—	—	—	REL	2E	rr	3
BIT # <i>opr</i> BIT <i>opr</i> BIT <i>opr</i> BIT <i>opr</i> ,X BIT <i>opr</i> ,X BIT ,X	Bit Test Accumulator with Memory Byte	(A) $\wedge$ (M)	—	—	↑	↓	—	IMM DIR EXT IX2 IX1 IX	A5 B5 C5 D5 E5 F5	ii dd hh ll ee ff ff p	2 3 4 5 4 3
BLO <i>rel</i>	Branch if Lower (Same as BCS)	$PC \leftarrow (PC) + 2 + rel ? C = 1$	—	—	—	—	—	REL	25	rr	3
BLS <i>rel</i>	Branch if Lower or Same	$PC \leftarrow (PC) + 2 + rel ? C \vee Z = 1$	—	—	—	—	—	REL	23	rr	3
BMC <i>rel</i>	Branch if Interrupt Mask Clear	$PC \leftarrow (PC) + 2 + rel ? I = 0$	—	—	—	—	—	REL	2C	rr	3
BMI <i>rel</i>	Branch if Minus	$PC \leftarrow (PC) + 2 + rel ? N = 1$	—	—	—	—	—	REL	2B	rr	3
BMS <i>rel</i>	Branch if Interrupt Mask Set	$PC \leftarrow (PC) + 2 + rel ? I = 1$	—	—	—	—	—	REL	2D	rr	3
BNE <i>rel</i>	Branch if Not Equal	$PC \leftarrow (PC) + 2 + rel ? Z = 0$	—	—	—	—	—	REL	26	rr	3
BPL <i>rel</i>	Branch if Plus	$PC \leftarrow (PC) + 2 + rel ? N = 0$	—	—	—	—	—	REL	2A	rr	3
BRA <i>rel</i>	Branch Always	$PC \leftarrow (PC) + 2 + rel ? 1 = 1$	—	—	—	—	—	REL	20	rr	3
BRCLR <i>n opr rel</i>	Branch if bit n clear	$PC \leftarrow (PC) + 2 + rel ? Mn = 0$	—	—	—	—	↑	DIR (b0) DIR (b1) DIR (b2) DIR (b3) DIR (b4) DIR (b5) DIR (b6) DIR (b7)	01 03 05 07 09 0B 0D 0F	dd rr dd rr dd rr dd rr dd rr dd rr dd rr dd rr	5 5 5 5 5 5 5 5

**Table 11-6. Instruction Set Summary (Sheet 3 of 7)**

Source Form	Operation	Description	Effect on CCR					Address Mode	Opcode	Operand	Cycles
			H	I	N	Z	C				
BRSET <i>n opr rel</i>	Branch if Bit n Set	$PC \leftarrow (PC) + 2 + rel ? Mn = 1$	—	—	—	—	↓	DIR (b0)	00	dd rr	5
			—	—	—	—	↓	DIR (b1)	02	dd rr	5
			—	—	—	—	↓	DIR (b2)	04	dd rr	5
			—	—	—	—	↓	DIR (b3)	06	dd rr	5
			—	—	—	—	↓	DIR (b4)	08	dd rr	5
			—	—	—	—	↓	DIR (b5)	0A	dd rr	5
			—	—	—	—	↓	DIR (b6)	0C	dd rr	5
			—	—	—	—	↓	DIR (b7)	0E	dd rr	5
BRN <i>rel</i>	Branch Never	$PC \leftarrow (PC) + 2 + rel ? 1 = 0$	—	—	—	—	REL	21	rr	3	
BSET <i>n opr</i>	Set Bit n	$Mn \leftarrow 1$	—	—	—	—	—	DIR (b0)	10	dd	5
			—	—	—	—	—	DIR (b1)	12	dd	5
			—	—	—	—	—	DIR (b2)	14	dd	5
			—	—	—	—	—	DIR (b3)	16	dd	5
			—	—	—	—	—	DIR (b4)	18	dd	5
			—	—	—	—	—	DIR (b5)	1A	dd	5
			—	—	—	—	—	DIR (b6)	1C	dd	5
			—	—	—	—	—	DIR (b7)	1E	dd	5
BSR <i>rel</i>	Branch to Subroutine	$PC \leftarrow (PC) + 2$ ; push (PCL) $SP \leftarrow (SP) - 1$ ; push (PCH) $SP \leftarrow (SP) - 1$ $PC \leftarrow (PC) + rel$	—	—	—	—	REL	AD	rr	6	
CLC	Clear Carry Bit	$C \leftarrow 0$	—	—	—	0	INH	98		2	
CLI	Clear Interrupt Mask	$I \leftarrow 0$	—	0	—	—	INH	9A		2	
CLR <i>opr</i> CLRA CLR X CLR <i>opr,X</i> CLR ,X	Clear Byte	$M \leftarrow \$00$	—	—	—	—	—	DIR	3F	dd	5
		$A \leftarrow \$00$	—	—	—	—	—	INH	4F		3
		$X \leftarrow \$00$	—	—	0	1	—	INH	5F		3
		$M \leftarrow \$00$	—	—	—	—	—	IX1	6F	ff	6
		$M \leftarrow \$00$	—	—	—	—	—	IX	7F		5
CMP # <i>opr</i> CMP <i>opr</i> CMP <i>opr</i> CMP <i>opr,X</i> CMP <i>opr,X</i> CMP ,X	Compare Accumulator with Memory Byte	$(A) - (M)$	—	—	↓	↓	↓	IMM	A1	ii	2
			—	—	↓	↓	↓	DIR	B1	dd	3
			—	—	↓	↓	↓	EXT	C1	hh ll	4
			—	—	↓	↓	↓	IX2	D1	ee ff	5
			—	—	↓	↓	↓	IX1	E1	ff	4
			—	—	↓	↓	↓	IX	F1		3
COM <i>opr</i> COMA COM X COM <i>opr,X</i> COM ,X	Complement Byte (One's Complement)	$M \leftarrow (\overline{M}) = \$FF - (M)$	—	—	↓	↓	1	DIR	33	dd	5
		$A \leftarrow (\overline{A}) = \$FF - (M)$	—	—	↓	↓	1	INH	43		3
		$X \leftarrow (\overline{X}) = \$FF - (M)$	—	—	↓	↓	1	INH	53		3
		$M \leftarrow (\overline{M}) = \$FF - (M)$	—	—	↓	↓	1	IX1	63	ff	6
		$M \leftarrow (\overline{M}) = \$FF - (M)$	—	—	↓	↓	1	IX	73		5

**Table 11-6. Instruction Set Summary (Sheet 4 of 7)**

Source Form	Operation	Description	Effect on CCR					Address Mode	Opcode	Operand	Cycles
			H	I	N	Z	C				
CPX #opr CPX opr CPX opr CPX opr,X CPX opr,X CPX ,X	Compare Index Register with Memory Byte	(X) – (M)	—	—	↑	↓	1	IMM DIR EXT IX2 IX1 IX	A3 B3 C3 D3 E3 F3	ii dd hh ll ee ff ff	2 3 4 5 4 3
DEC opr DECA DECX DEC opr,X DEC ,X	Decrement Byte	M ← (M) – 1 A ← (A) – 1 X ← (X) – 1 M ← (M) – 1 M ← (M) – 1	—	—	↑	↓	—	DIR INH INH IX1 IX	3A 4A 5A 6A 7A	dd  ff	5 3 3 6 5
EOR #opr EOR opr EOR opr EOR opr,X EOR opr,X EOR ,X	EXCLUSIVE OR Accumulator with Memory Byte	A ← (A) ⊕ (M)	—	—	↑	↓	—	IMM DIR EXT IX2 IX1 IX	A8 B8 C8 D8 E8 F8	ii dd hh ll ee ff ff	2 3 4 5 4 3
INC opr INCA INCX INC opr,X INC ,X	Increment Byte	M ← (M) + 1 A ← (A) + 1 X ← (X) + 1 M ← (M) + 1 M ← (M) + 1	—	—	↑	↓	—	DIR INH INH IX1 IX	3C 4C 5C 6C 7C	dd  ff	5 3 3 6 5
JMP opr JMP opr JMP opr,X JMP opr,X JMP ,X	Unconditional Jump	PC ← Jump Address	—	—	—	—	—	DIR EXT IX2 IX1 IX	BC CC DC EC FC	dd hh ll ee ff ff	2 3 4 3 2
JSR opr JSR opr JSR opr,X JSR opr,X JSR ,X	Jump to Subroutine	PC ← (PC) + n (n = 1, 2, or 3) Push (PCL); SP ← (SP) – 1 Push (PCH); SP ← (SP) – 1 PC ← Conditional Address	—	—	—	—	—	DIR EXT IX2 IX1 IX	BD CD DD ED FD	dd hh ll ee ff ff	5 6 7 6 5
LDA #opr LDA opr LDA opr LDA opr,X LDA opr,X LDA ,X	Load Accumulator with Memory Byte	A ← (M)	—	—	↑	↓	—	IMM DIR EXT IX2 IX1 IX	A6 B6 C6 D6 E6 F6	ii dd hh ll ee ff ff	2 3 4 5 4 3

**Table 11-6. Instruction Set Summary (Sheet 5 of 7)**

Source Form	Operation	Description	Effect on CCR					Address Mode	Opcode	Operand	Cycles
			H	I	N	Z	C				
LDX #opr LDX opr LDX opr LDX opr,X LDX opr,X LDX ,X	Load Index Register with Memory Byte	$X \leftarrow (M)$	—	—	↑	↑	—	IMM DIR EXT IX2 IX1 IX	AE BE CE DE EE FE	ii dd hh ll ee ff ff	2 3 4 5 4 3
LSL opr LSLA LSLX LSL opr,X LSL ,X	Logical Shift Left (Same as ASL)		—	—	↑	↑	↑	DIR INH INH IX1 IX	38 48 58 68 78	dd ff	5 3 3 6 5
LSR opr LSRA LSRX LSR opr,X LSR ,X	Logical Shift Right		—	—	0	↑	↑	DIR INH INH IX1 IX	34 44 54 64 74	dd ff	5 3 3 6 5
MUL	Unsigned Multiply	$X : A \leftarrow (X) \times (A)$	0	—	—	—	0	INH	42		11
NEG opr NEGA NEGX NEG opr,X NEG ,X	Negate Byte (Two's Complement)	$M \leftarrow -(M) = \$00 - (M)$ $A \leftarrow -(A) = \$00 - (A)$ $X \leftarrow -(X) = \$00 - (X)$ $M \leftarrow -(M) = \$00 - (M)$ $M \leftarrow -(M) = \$00 - (M)$	—	—	↑	↑	↑	DIR INH INH IX1 IX	30 40 50 60 70	ii ff	5 3 3 6 5
NOP	No Operation		—	—	—	—	—	INH	9D		2
ORA #opr ORA opr ORA opr ORA opr,X ORA opr,X ORA ,X	Logical OR Accumulator with Memory	$A \leftarrow (A) \vee (M)$	—	—	↑	↑	—	IMM DIR EXT IX2 IX1 IX	AA BA CA DA EA FA	ii dd hh ll ee ff ff	2 3 4 5 4 3
ROL opr ROLA ROLX ROL opr,X ROL ,X	Rotate Byte Left through Carry Bit		—	—	↑	↑	↑	DIR INH INH IX1 IX	39 49 59 69 79	dd ff	5 3 3 6 5
ROR opr RORA RORX ROR opr,X ROR ,X	Rotate Byte Right through Carry Bit		—	—	↑	↑	↑	DIR INH INH IX1 IX	36 46 56 66 76	dd ff	5 3 3 6 5
RSP	Reset Stack Pointer	$SP \leftarrow \$00FF$	—	—	—	—	—	INH	9C		2

**Table 11-6. Instruction Set Summary (Sheet 6 of 7)**

Source Form	Operation	Description	Effect on CCR					Address Mode	Opcode	Operand	Cycles
			H	I	N	Z	C				
RTI	Return from Interrupt	SP ← (SP) + 1; Pull (CCR) SP ← (SP) + 1; Pull (A) SP ← (SP) + 1; Pull (X) SP ← (SP) + 1; Pull (PCH) SP ← (SP) + 1; Pull (PCL)	↑	↑	↑	↑	↑	INH	80		6
RTS	Return from Subroutine	SP ← (SP) + 1; Pull (PCH) SP ← (SP) + 1; Pull (PCL)	—	—	—	—	—	INH			
SBC #opr SBC opr SBC opr SBC opr,X SBC opr,X SBC ,X	Subtract Memory Byte and Carry Bit from Accumulator	A ← (A) – (M) – (C)	—	—	↑	↑	↑	IMM DIR EXT IX2 IX1 IX	A2 B2 C2 D2 E2 F2	ii dd hh ll ee ff ff	2 3 4 5 4 3
SEC	Set Carry Bit	C ← 1	—	—	—	—	1	INH	99		2
SEI	Set Interrupt Mask	I ← 1	—	1	—	—	—	INH	9B		2
STA opr STA opr STA opr,X STA opr,X STA ,X	Store Accumulator in Memory	M ← (A)	—	—	↑	↑	—	DIR EXT IX2 IX1 IX	B7 C7 D7 E7 F7	dd hh ll ee ff ff	4 5 6 5 4
STOP	Stop Oscillator and Enable $\overline{\text{IRQ}}$ Pin		—	0	—	—	—	INH	8E		2
STX opr STX opr STX opr,X STX opr,X STX ,X	Store Index Register In Memory	M ← (X)	—	—	↑	↑	—	DIR EXT IX2 IX1 IX	BF CF DF EF FF	dd hh ll ee ff ff	4 5 6 5 4
SUB #opr SUB opr SUB opr SUB opr,X SUB opr,X SUB ,X	Subtract Memory Byte from Accumulator	A ← (A) – (M)	—	—	↑	↑	↑	IMM DIR EXT IX2 IX1 IX	A0 B0 C0 D0 E0 F0	ii dd hh ll ee ff ff	2 3 4 5 4 3
SWI	Software Interrupt	PC ← (PC) + 1; Push (PCL) SP ← (SP) – 1; Push (PCH) SP ← (SP) – 1; Push (X) SP ← (SP) – 1; Push (A) SP ← (SP) – 1; Push (CCR) SP ← (SP) – 1; I ← 1 PCH ← Interrupt Vector High Byte PCL ← Interrupt Vector Low Byte	—	1	—	—	—	INH	83		10

**Table 11-6. Instruction Set Summary (Sheet 7 of 7)**

Source Form	Operation	Description	Effect on CCR					Address Mode	Opcode	Operand	Cycles
			H	I	N	Z	C				
TAX	Transfer Accumulator to Index Register	$X \leftarrow (A)$	—	—	—	—	—	INH	97		2
TST <i>opr</i> TSTA TSTX TST <i>opr,X</i> TST ,X	Test Memory Byte for Negative or Zero	$(M) - \$00$	—	—	—	—	—	DIR INH INH IX1 IX	3D 4D 5D 6D 7D	dd  ff	4 3 3 5 4
TXA	Transfer Index Register to Accumulator	$A \leftarrow (X)$	—	—	—	—	—	INH	9F		2
WAIT	Stop CPU Clock and Enable Interrupts		—	↕	—	—	—	INH	8F		2

A Accumulator  
 C Carry/borrow flag  
 CCR Condition code register  
 dd Direct address of operand  
 dd rr Direct address of operand and relative offset of branch instruction  
 DIR Direct addressing mode  
 ee ff High and low bytes of offset in indexed, 16-bit offset addressing  
 EXT Extended addressing mode  
 ff Offset byte in indexed, 8-bit offset addressing  
 H Half-carry flag  
 hh ll High and low bytes of operand address in extended addressing  
 I Interrupt mask  
 ii Immediate operand byte  
 IMM Immediate addressing mode  
 INH Inherent addressing mode  
 IX Indexed, no offset addressing mode  
 IX1 Indexed, 8-bit offset addressing mode  
 IX2 Indexed, 16-bit offset addressing mode  
 M Memory location  
 N Negative flag  
 n Any bit

*opr* Operand (one or two bytes)  
 PC Program counter  
 PCH Program counter high byte  
 PCL Program counter low byte  
 REL Relative addressing mode  
*rel* Relative program counter offset byte  
 rr Relative program counter offset byte  
 SP Stack pointer  
 X Index register  
 Z Zero flag  
 # Immediate value  
 ^ Logical AND  
 v Logical OR  
 ⊕ Logical EXCLUSIVE OR  
 ( ) Contents of  
 -( ) Negation (two's complement)  
 ← Loaded with  
 ? If  
 : Concatenated with  
 ↕ Set or cleared  
 — Not affected

## 11.6 Opcode Map

See **Table 11-7**.

Table 11-7. Opcode Map

MSB LSB	Bit Manipulation			Branch			Read-Modify-Write					Control			Register/Memory								
	DIR	DIR	DIR	REL	REL	REL	DIR	INH	INH	INH	IX1	IX	INH	INH	IMM	DIR	EXT	IX2	IX1	IX	MSB LSB		
0	5 DIR2	5 DIR2	3 DIR2	3 REL2	5 DIR1	3 REL2	3 DIR1	4 INH1	3 INH1	5 NEG1	6 NEG1	7 NEG1	8 INH1	9 INH1	2 IMM2	3 SUB3	4 SUB3	5 SUB3	4 SUB3	5 SUB3	4 SUB3	3 SUB3	0
1	5 DIR2	5 DIR2	3 DIR2	3 REL2	5 DIR1	3 REL2	3 DIR1	4 INH1	3 INH1	6 NEG1	6 NEG1	7 NEG1	8 INH1	9 INH1	2 IMM2	3 CMP3	4 CMP3	5 CMP3	4 CMP3	5 CMP3	4 CMP3	3 CMP3	1
2	5 DIR2	5 DIR2	3 DIR2	3 REL2	5 DIR1	3 REL2	3 DIR1	4 INH1	3 INH1	6 NEG1	6 NEG1	7 NEG1	8 INH1	9 INH1	2 IMM2	3 SBC3	4 SBC3	5 SBC3	4 SBC3	5 SBC3	4 SBC3	3 SBC3	2
3	5 DIR2	5 DIR2	3 DIR2	3 REL2	5 DIR1	3 REL2	3 DIR1	4 INH1	3 INH1	6 NEG1	6 NEG1	7 NEG1	8 INH1	9 INH1	2 IMM2	3 CPX3	4 CPX3	5 CPX3	4 CPX3	5 CPX3	4 CPX3	3 CPX3	3
4	5 DIR2	5 DIR2	3 DIR2	3 REL2	5 DIR1	3 REL2	3 DIR1	4 INH1	3 INH1	6 NEG1	6 NEG1	7 NEG1	8 INH1	9 INH1	2 IMM2	3 AND3	4 AND3	5 AND3	4 AND3	5 AND3	4 AND3	3 AND3	4
5	5 DIR2	5 DIR2	3 DIR2	3 REL2	5 DIR1	3 REL2	3 DIR1	4 INH1	3 INH1	6 NEG1	6 NEG1	7 NEG1	8 INH1	9 INH1	2 IMM2	3 BIT3	4 BIT3	5 BIT3	4 BIT3	5 BIT3	4 BIT3	3 BIT3	5
6	5 DIR2	5 DIR2	3 DIR2	3 REL2	5 DIR1	3 REL2	3 DIR1	4 INH1	3 INH1	6 NEG1	6 NEG1	7 NEG1	8 INH1	9 INH1	2 IMM2	3 LDA3	4 LDA3	5 LDA3	4 LDA3	5 LDA3	4 LDA3	3 LDA3	6
7	5 DIR2	5 DIR2	3 DIR2	3 REL2	5 DIR1	3 REL2	3 DIR1	4 INH1	3 INH1	6 NEG1	6 NEG1	7 NEG1	8 INH1	9 INH1	2 IMM2	3 STA3	4 STA3	5 STA3	4 STA3	5 STA3	4 STA3	3 STA3	7
8	5 DIR2	5 DIR2	3 DIR2	3 REL2	5 DIR1	3 REL2	3 DIR1	4 INH1	3 INH1	6 NEG1	6 NEG1	7 NEG1	8 INH1	9 INH1	2 IMM2	3 EOR3	4 EOR3	5 EOR3	4 EOR3	5 EOR3	4 EOR3	3 EOR3	8
9	5 DIR2	5 DIR2	3 DIR2	3 REL2	5 DIR1	3 REL2	3 DIR1	4 INH1	3 INH1	6 NEG1	6 NEG1	7 NEG1	8 INH1	9 INH1	2 IMM2	3 ADC3	4 ADC3	5 ADC3	4 ADC3	5 ADC3	4 ADC3	3 ADC3	9
A	5 DIR2	5 DIR2	3 DIR2	3 REL2	5 DIR1	3 REL2	3 DIR1	4 INH1	3 INH1	6 NEG1	6 NEG1	7 NEG1	8 INH1	9 INH1	2 IMM2	3 ORA3	4 ORA3	5 ORA3	4 ORA3	5 ORA3	4 ORA3	3 ORA3	A
B	5 DIR2	5 DIR2	3 DIR2	3 REL2	5 DIR1	3 REL2	3 DIR1	4 INH1	3 INH1	6 NEG1	6 NEG1	7 NEG1	8 INH1	9 INH1	2 IMM2	3 ADD3	4 ADD3	5 ADD3	4 ADD3	5 ADD3	4 ADD3	3 ADD3	B
C	5 DIR2	5 DIR2	3 DIR2	3 REL2	5 DIR1	3 REL2	3 DIR1	4 INH1	3 INH1	6 NEG1	6 NEG1	7 NEG1	8 INH1	9 INH1	2 IMM2	3 JMP3	4 JMP3	5 JMP3	4 JMP3	5 JMP3	4 JMP3	3 JMP3	C
D	5 DIR2	5 DIR2	3 DIR2	3 REL2	5 DIR1	3 REL2	3 DIR1	4 INH1	3 INH1	6 NEG1	6 NEG1	7 NEG1	8 INH1	9 INH1	2 IMM2	3 JSR3	4 JSR3	5 JSR3	4 JSR3	5 JSR3	4 JSR3	3 JSR3	D
E	5 DIR2	5 DIR2	3 DIR2	3 REL2	5 DIR1	3 REL2	3 DIR1	4 INH1	3 INH1	6 NEG1	6 NEG1	7 NEG1	8 INH1	9 INH1	2 IMM2	3 LDX3	4 LDX3	5 LDX3	4 LDX3	5 LDX3	4 LDX3	3 LDX3	E
F	5 DIR2	5 DIR2	3 DIR2	3 REL2	5 DIR1	3 REL2	3 DIR1	4 INH1	3 INH1	6 NEG1	6 NEG1	7 NEG1	8 INH1	9 INH1	2 IMM2	3 STX3	4 STX3	5 STX3	4 STX3	5 STX3	4 STX3	3 STX3	F

INH = Inherent  
 IMM = Immediate  
 DIR = Direct  
 EXT = Extended  
 REL = Relative  
 IX = Indexed, No Offset  
 IX1 = Indexed, 8-Bit Offset  
 IX2 = Indexed, 16-Bit Offset  
 MSB of Opcode in Hexadecimal  
 0  
 Number of Cycles  
 Opcode Mnemonic  
 Number of Bytes/Addressing Mode  
 0  
 BRSET0  
 3 DIR





## Section 12. Electrical Specifications

### 12.1 Contents

12.2	Maximum Ratings . . . . .	122
12.3	Operating Temperature . . . . .	123
12.4	Thermal Characteristics . . . . .	123
12.5	Power Considerations. . . . .	124
12.6	5.0-Volt DC Electrical Characteristics. . . . .	125
12.7	3.3-Volt DC Electrical Characteristics. . . . .	126
12.8	5.0-Volt Control Timing . . . . .	128
12.9	3.3-Volt Control Timing . . . . .	129
12.10	5.0-Volt Serial Peripheral Interface Timing. . . . .	132
12.11	3.3-Volt Serial Peripheral Interface Timing. . . . .	133

## 12.2 Maximum Ratings

Maximum ratings are the extreme limits to which the microcontroller unit (MCU) can be exposed without permanently damaging it.

The MCU contains circuitry to protect the inputs against damage from high static voltages; however, do not apply voltages higher than those shown in the table here. Keep  $V_{In}$  and  $V_{Out}$  within the range  $V_{SS} \leq (V_{In} \text{ or } V_{Out}) \leq V_{DD}$ . Connect unused inputs to the appropriate voltage level, either  $V_{SS}$  or  $V_{DD}$ .

Rating	Symbol	Value	Unit
Supply voltage	$V_{DD}$	-0.3 to +7.0	V
Input voltage Normal operation Self-check mode ( $\overline{IRQ}$ pin only)	$V_{In}$ $V_{TST}$	$V_{SS} - 0.3$ to $V_{DD} + 0.3$ $V_{SS} - 0.3$ to $2 \times V_{DD} + 0.3$	V
Current drain per pin (Excluding $V_{DD}$ and $V_{SS}$ )	I	25	mA
Storage temperature range	$T_{STG}$	-65 to +150	°C

**NOTE:** *This device is not guaranteed to operate properly at the maximum ratings. Refer to **12.6 5.0-Volt DC Electrical Characteristics** for guaranteed operating conditions.*

## 12.3 Operating Temperature

Characteristic	Symbol	Value	Unit
Operating temperature range MC68HC05C9AP, FN, B, FB MC68HC05C9AMP, MFN, MB, MFB	$T_A$	$T_L$ to $T_H$ 0 to +70 -40 to +125	°C

## 12.4 Thermal Characteristics

Characteristic	Symbol	Value	Unit
Thermal resistance plastic dual in-line (PDIP)	$\theta_{JA}$	60	°C/W
Thermal resistance plastic-leaded chip carrier (PLCC)	$\theta_{JA}$	70	°C/W
Thermal resistance quad flat pack (QFP)	$\theta_{JA}$	95	°C/W
Thermal resistance plastic shrink DIP (SDIP)	$\theta_{JA}$	60	°C/W

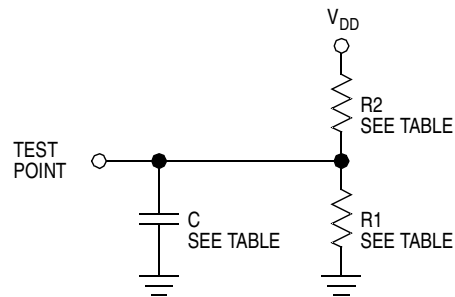

$V_{DD} = 4.5 \text{ V}$

Pins	R1	R2	C
PA7-PA0 PB7-PB0 PC7-PC0 PD5-PD0, PD7	3.26 $\Omega$	2.38 $\Omega$	50 pF

$V_{DD} = 3.0 \text{ V}$

Pins	R1	R2	C
PA7-PA0 PB7-PB0 PC7-PC0 PD5-PD0, PD7	10.91 $\Omega$	6.32 $\Omega$	50 pF

**Figure 12-1. Test Load**

## 12.5 Power Considerations

The average chip-junction temperature,  $T_J$ , in °C, can be obtained from:

$$T_J = T_A + (P_D \times \theta_{JA}) \quad (1)$$

where:

$T_A$  = Ambient temperature, °C

$\theta_{JA}$  = Package thermal resistance, junction to ambient, °C/W

$P_D = P_{INT} + P_{I/O}$

$P_{INT} = I_{DD} \times V_{DD}$  watts (chip internal power)

$P_{I/O}$  = Power dissipation on input and output pins (user determined)

For most applications,  $P_{I/O} \ll P_{INT}$  and can be neglected.

The following is an approximate relationship between  $P_D$  and  $T_J$  (neglecting  $P_J$ ):

$$P_D = K \div (T_J + 273^\circ\text{C}) \quad (2)$$

Solving equations (1) and (2) for K gives:

$$K = P_D \times (T_A + 273^\circ\text{C}) + \theta_{JA} \times (P_D)^2 \quad (3)$$

where K is a constant pertaining to the particular part. K can be determined from equation (3) by measuring  $P_D$  (at equilibrium) for a known  $T_A$ . Using this value of K, the values of  $P_D$  and  $T_J$  can be obtained by solving equations (1) and (2) iteratively for any value of  $T_A$ .

## 12.6 5.0-Volt DC Electrical Characteristics

Characteristic <sup>(1) (2)</sup>	Symbol	Min	Typ	Max	Unit
Output voltage $I_{Load} = 10.0 \mu A$ $I_{Load} = -10.0 \mu A$	$V_{OL}$ $V_{OH}$	— $V_{DD}-0.1$	— —	0.1 —	V
Output high voltage ( $I_{Load} = -0.8$ mA) PA7–PA0, PB7–PB0, PC6–PC0, TCMP, PD7, PD0 ( $I_{Load} = -1.6$ mA) PD5–PD1 ( $I_{Load} = -5.0$ mA) PC7	$V_{OH}$	$V_{DD}-0.8$ $V_{DD}-0.8$ $V_{DD}-0.8$	— — —	— — —	V
Output low voltage ( $I_{Load} = 1.6$ mA) PA7–PA0, PB7–PB0, PC6–PC0, PD7, PD5–PD0, TCMP ( $I_{Load} = 10$ mA) PC7	$V_{OL}$	— —	— —	0.4 0.4	V
Input high voltage PA7–PA0, PB7–PB0, PC7–PC0, PD7, PD5–PD0, TCAP, $\overline{IRQ}$ , $\overline{RESET}$ , OSC1	$V_{IH}$	$0.7 \times V_{DD}$	—	$V_{DD}$	V
Input low voltage PA7–PA0, PB7–PB0, PC7–PC0, PD7, PD5–PD0, TCAP, $\overline{IRQ}$ , $\overline{RESET}$ , OSC1	$V_{IL}$	$V_{SS}$	—	$0.2 \times V_{DD}$	V
Supply current (4.5–5.5 Vdc @ $f_{OP} = 2.1$ MHz) Run <sup>(3)</sup> Wait <sup>(4)</sup> Stop <sup>(5)</sup> 25°C 0 to 70°C –40 to +125°C	$I_{DD}$	— — — — —	3.5 1.0 1.0 2.0 7.0	5.25 3.25 20.0 40.0 50.0	mA mA $\mu A$ $\mu A$ $\mu A$
I/O ports hi-z leakage current PA7–PA0, PB7–PB0 (without pullup) PC7–PC0, PD7, PD5–PD0	$I_{OZ}$	—	1.0	10	$\mu A$
Input current $\overline{RESET}$ , $\overline{IRQ}$ , OSC1, TCAP, PD7, PD5–PD0	$I_{In}$	—	0.5	1	$\mu A$
Input pullup current <sup>(6)</sup> PB7–PB0 (with pullup)	$I_{In}$	5	—	60	$\mu A$
Capacitance Ports (as input or output) $\overline{RESET}$ , $\overline{IRQ}$ , OSC1, TCAP, PD7, PD5, PD0	$C_{Out}$ $C_{In}$	— —	— —	12 8	pF

- $V_{DD} = 5.0$  Vdc  $\pm 10\%$ ,  $V_{SS} = 0$  Vdc,  $T_A = -40$  to  $+125^\circ C$ , unless otherwise noted
- Typical values reflect measurements taken on average processed devices at the midpoint of voltage range,  $25^\circ C$  only.
- Run (operating)  $I_{DD}$  measured using external square wave clock source; all I/O pins configured as inputs, port B =  $V_{DD}$ , all other inputs  $V_{IL} = 0.2$  V,  $V_{IH} = V_{DD} - 0.2$  V; no dc loads; less than 50 pF on all outputs;  $C_L = 20$  pF on OSC2
- Wait  $I_{DD}$  measured using external square wave clock source; all I/O pins configured as inputs, port B =  $V_{DD}$ , all other inputs  $V_{IL} = 0.2$  V,  $V_{IH} = V_{DD} - 0.2$  V; no dc loads; less than 50 pF on all outputs;  $C_L = 20$  pF on OSC2. Wait  $I_{DD}$  is affected linearly by the OSC2 capacitance.
- Stop  $I_{DD}$  measured with OSC1 = 0.2 V; all I/O pins configured as inputs, port B =  $V_{DD}$ , all other inputs  $V_{IL} = 0.2$  V,  $V_{IH} = V_{DD} - 0.2$  V
- Input pullup current measured with  $V_{IL} = 0.2$  V

# Electrical Specifications

## 12.7 3.3-Volt DC Electrical Characteristics

Characteristic <sup>(1) (2)</sup>	Symbol	Min	Typ	Max	Unit
Output voltage $I_{Load} = 10.0 \mu A$ $I_{Load} = -10.0 \mu A$	$V_{OL}$ $V_{OH}$	— $V_{DD}-0.1$	— —	0.1 —	V
Output high voltage ( $I_{Load} = -0.2$ mA) PA7–PA0, PB7–PB0, PC6–PC0, TCMP, PD7, PD0 ( $I_{Load} = -0.4$ mA) PD5–PD1 ( $I_{Load} = -1.5$ mA) PC7	$V_{OH}$	$V_{DD}-0.3$ $V_{DD}-0.3$ $V_{DD}-0.3$	— — —	— — —	V
Output low voltage ( $I_{Load} = 0.4$ mA) PA7–PA0, PB7–PB0, PC6–PC0, PD7, PD5–PD0, TCMP ( $I_{Load} = 6$ mA) PC7	$V_{OL}$	— —	— —	0.3 0.3	V
Input high voltage PA7–PA0, PB7–PB0, PC7–PC0, PD7, PD5–PD0, TCAP, $\overline{IRQ}$ , RESET, OSC1	$V_{IH}$	$0.7 \times V_{DD}$	—	$V_{DD}$	V
Input low voltage PA7–PA0, PB7–PB0, PC7–PC0, PD7, PD5–PD0, TCAP, $\overline{IRQ}$ , $\overline{RESET}$ , OSC1	$V_{IL}$	$V_{SS}$	—	$0.2 \times V_{DD}$	V
Supply current (3.0–3.6 Vdc @ $f_{OP} = 1.0$ MHz) Run <sup>(3)</sup> Wait <sup>(4)</sup> Stop <sup>(5)</sup> 25°C 0 to 70°C –40 to +125°C	$I_{DD}$	— — — — —	1.0 500 1.0 1.0 2.5	1.6 900 8 16 20	mA $\mu A$ $\mu A$ $\mu A$ $\mu A$
I/O ports hi-z leakage current PA7–PA0, PB7–PB0 (without pullup) PC7–PC0, PD7, PD5–PD0	$I_{OZ}$	—	1.0	10	$\mu A$
Input current $\overline{RESET}$ , $\overline{IRQ}$ , OSC1, TCAP, PD7, PD5–PD0	$I_{In}$	—	0.5	1	$\mu A$
Input pullup current <sup>(6)</sup> PB7–PB0 (with pullup)	$I_{In}$	0.5	—	20	$\mu A$
Capacitance Ports (as input or output) $\overline{RESET}$ , $\overline{IRQ}$ , OSC1, TCAP, PD7, PD5, PD0	$C_{Out}$ $C_{In}$	— —	— —	12 8	pF

- $V_{DD} = 3.3 \text{ Vdc} \pm 0.3 \text{ Vdc}$ ,  $V_{SS} = 0 \text{ Vdc}$ ,  $T_A = -40$  to  $+125^\circ\text{C}$ , unless otherwise noted
- Typical values reflect measurements taken on average processed devices at the midpoint of voltage range,  $25^\circ\text{C}$  only.
- Run (operating)  $I_{DD}$  measured using external square wave clock source; all I/O pins configured as inputs, port B =  $V_{DD}$ , all other inputs  $V_{IL} = 0.2 \text{ V}$ ,  $V_{IH} = V_{DD} - 0.2 \text{ V}$ ; no dc loads; less than 50 pF on all outputs;  $C_L = 20 \text{ pF}$  on OSC2
- Wait  $I_{DD}$  measured using external square wave clock source; all I/O pins configured as inputs, port B =  $V_{DD}$ , all other inputs  $V_{IL} = 0.2 \text{ V}$ ,  $V_{IH} = V_{DD} - 0.2 \text{ V}$ ; no dc loads; less than 50 pF on all outputs;  $C_L = 20 \text{ pF}$  on OSC2. Wait  $I_{DD}$  is affected linearly by the OSC2 capacitance.
- Stop  $I_{DD}$  measured with OSC1 = 0.2 V; all I/O pins configured as inputs, port B =  $V_{DD}$ , all other inputs  $V_{IL} = 0.2 \text{ V}$ ,  $V_{IH} = V_{DD} - 0.2 \text{ V}$
- Input pullup current measured with  $V_{IL} = 0.2 \text{ V}$

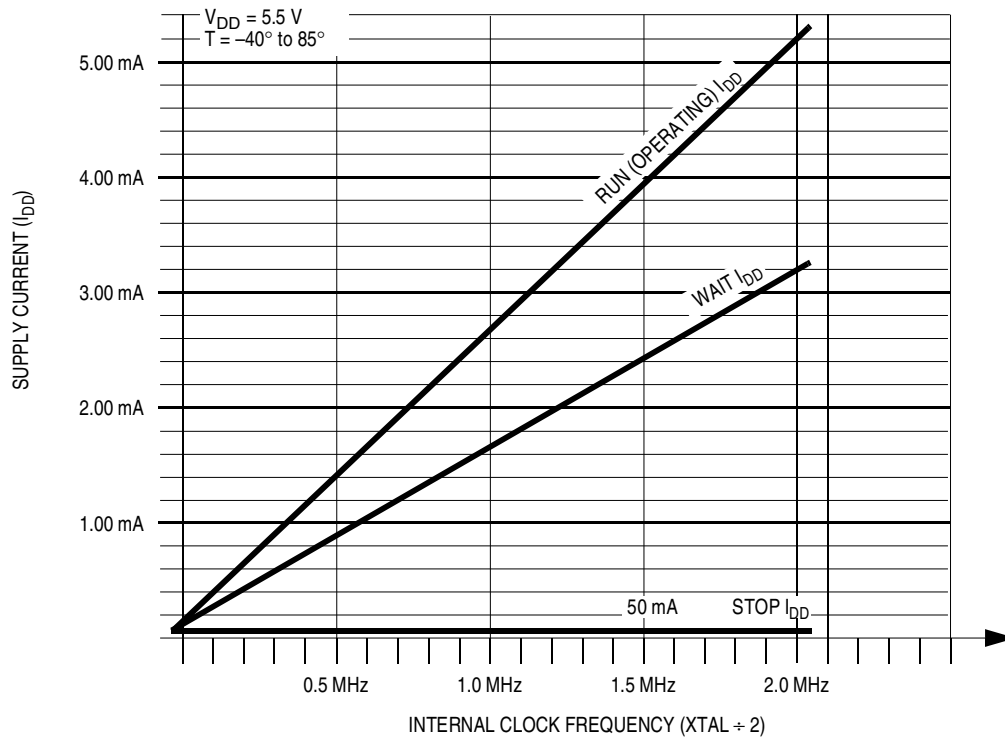

Figure 12-2. Maximum Supply Current versus Internal Clock Frequency,  $V_{DD} = 5.5 V$

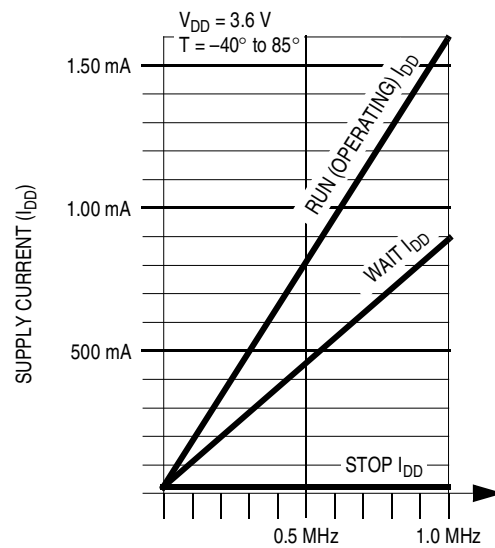

Figure 12-3. Maximum Supply Current versus Internal Clock Frequency,  $V_{DD} = 3.6 V$

## 12.8 5.0-Volt Control Timing

Characteristic <sup>(1)</sup>	Symbol	Min	Max	Unit
Frequency of operation Crystal External clock	$f_{OSC}$	— dc	4.2 4.2	MHz
Internal operating frequency ( $f_{OSC} \div 2$ ) Crystal External clock	$f_{OP}$	— dc	2.1 2.1	MHz
Cycle time	$t_{cyc}$	480	—	ns
Crystal oscillator startup time	$t_{OXOV}$	—	100	ms
Stop recovery startup time (crystal oscillator)	$t_{LCH}$	—	100	ms
$\overline{RESET}$ pulse width	$t_{RL}$	1.5	—	$t_{cyc}$
Timer Resolution <sup>(2)</sup> Input capture pulse width Input capture pulse period	$t_{RESL}$ $t_{TH}, t_{TL}$ $t_{TLTL}$	4.0 125 (3)	— — —	$t_{cyc}$ ns $t_{cyc}$
Interrupt pulse width low (edge-triggered)	$t_{LIH}$	125	—	ns
Interrupt pulse period	$t_{LIL}$	(4)	—	$t_{cyc}$
OSC1 pulse width	$t_{OH}, t_{OL}$	90	—	ns

1.  $V_{DD} = 5.0 \text{ Vdc} \pm 10\%$ ,  $V_{SS} = 0 \text{ Vdc}$ ,  $T_A = -40$  to  $+125^\circ\text{C}$ , unless otherwise noted

2. Because a 2-bit prescaler in the timer must count four internal cycles ( $t_{CYC}$ ), this is the limiting minimum factor in determining the timer resolution.

3. The minimum period  $t_{TLTL}$  should not be less than the number of cycle times it takes to execute the capture interrupt service routine plus  $24 t_{CYC}$ .

4. The minimum  $t_{LIL}$  should not be less than the number of cycle times it takes to execute the interrupt service routine plus  $19 t_{CYC}$ .



## 12.9 3.3-Volt Control Timing

Characteristic <sup>(1)</sup>	Symbol	Min	Max	Unit
Frequency of operation Crystal External clock	$f_{OSC}$	— dc	2.0 2.0	MHz
Internal operating frequency ( $f_{OSC} \div 2$ ) Crystal External clock	$f_{OP}$	— dc	1.0 1.0	MHz
Cycle time	$t_{cyc}$	1000	—	ns
Crystal oscillator start-up time	$t_{OXOV}$	—	100	ms
Stop recovery start-up time (crystal oscillator)	$t_{LCH}$	—	100	ms
$\overline{RESET}$ pulse width	$t_{RL}$	1.5	—	$t_{cyc}$
Timer Resolution <sup>(2)</sup> Input capture pulse width Input capture pulse period	$t_{RESL}$ $t_{TH}, t_{TL}$ $t_{TLTL}$	4.0 125 (3)	— — —	$t_{cyc}$ ns $t_{cyc}$
Interrupt pulse width low (edge-triggered)	$t_{LILH}$	250	—	ns
Interrupt pulse period	$t_{LIL}$	(4)	—	$t_{cyc}$
OSC1 pulse width	$t_{OH}, t_{OL}$	200	—	ns

1.  $V_{DD} = 3.3 \text{ Vdc} \pm 0.3 \text{ Vdc}$ ,  $V_{SS} = 0 \text{ Vdc}$ ,  $T_A = -40$  to  $+125^\circ\text{C}$ , unless otherwise noted
2. Because a 2-bit prescaler in the timer must count four internal cycles ( $t_{CYC}$ ), this is the limiting minimum factor in determining the timer resolution.
3. The minimum period  $t_{TLTL}$  should not be less than the number of cycle times it takes to execute the capture interrupt service routine plus  $24 t_{CYC}$ .
4. The minimum  $t_{LIL}$  should not be less than the number of cycle times it takes to execute the interrupt service routine plus  $19 t_{CYC}$ .

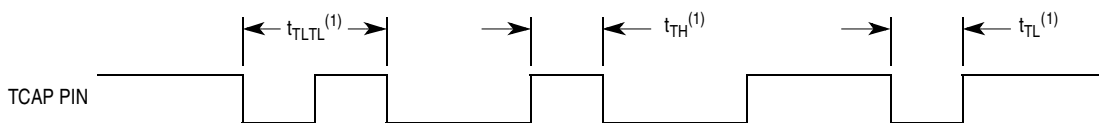

1. Refer to timer resolution data in 12.8 5.0-Volt Control Timing and 12.9 3.3-Volt Control Timing.

**Figure 12-4. TCAP Timing Relationships**

# Electrical Specifications

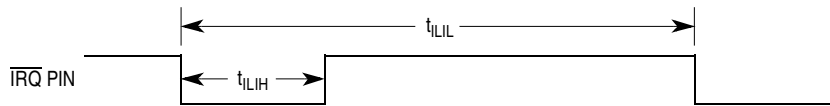

a. **Edge-Sensitive Trigger Condition.** The minimum pulse width ( $t_{\text{LIH}}$ ) is either 125 ns ( $f_{\text{OP}} = 2.1$  MHz) or 250 ns ( $f_{\text{OP}} = 1$  MHz). The period  $t_{\text{LIL}}$  should not be less than the number of  $t_{\text{CYC}}$  cycles it takes to execute the interrupt service routine plus 19  $t_{\text{CYC}}$  cycles.

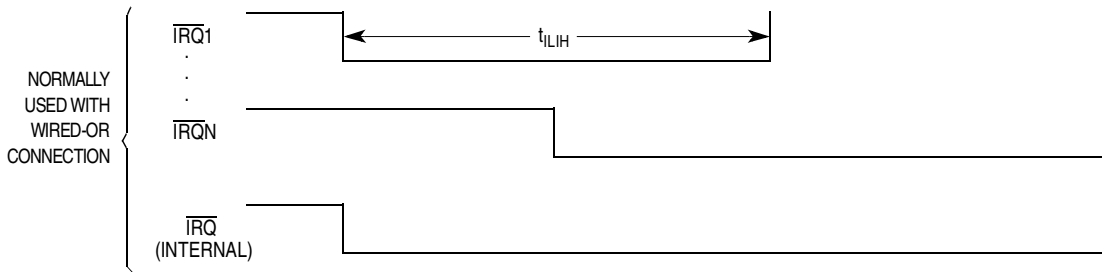

b. **Level-Sensitive Trigger Condition.** If after servicing an interrupt the  $\overline{\text{IRQ}}$  remains low, the next interrupt is recognized.

**Figure 12-5. External Interrupt Timing**

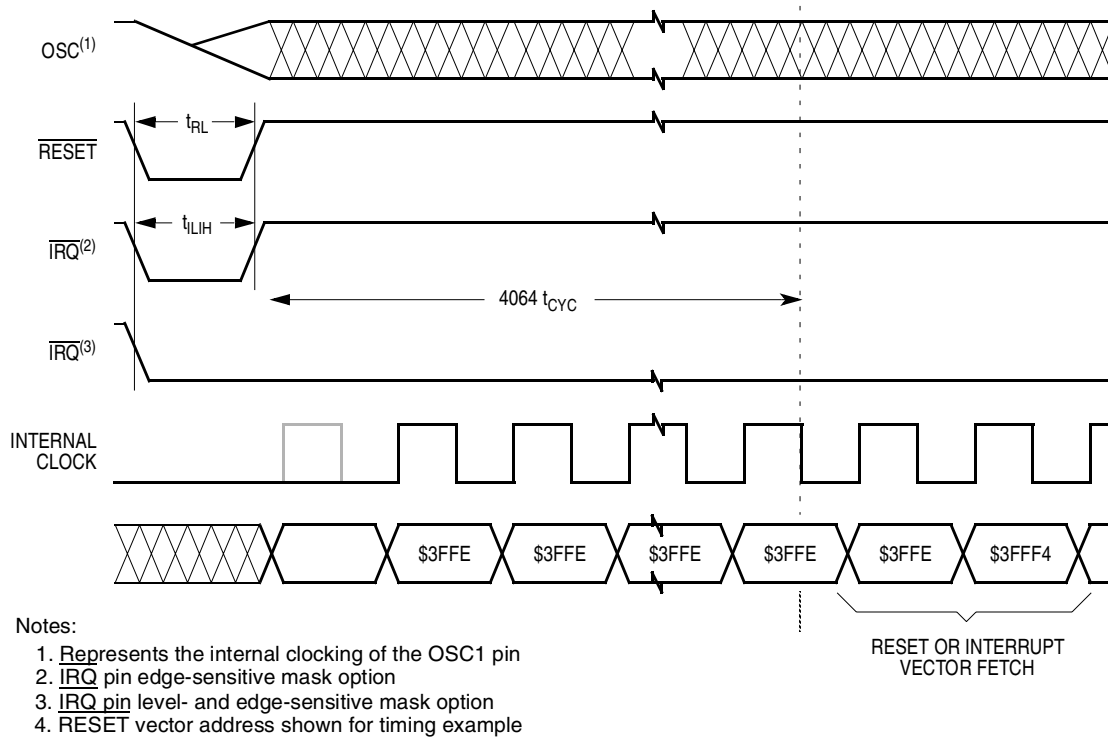

**Figure 12-6. Stop Recovery Timing Diagram**

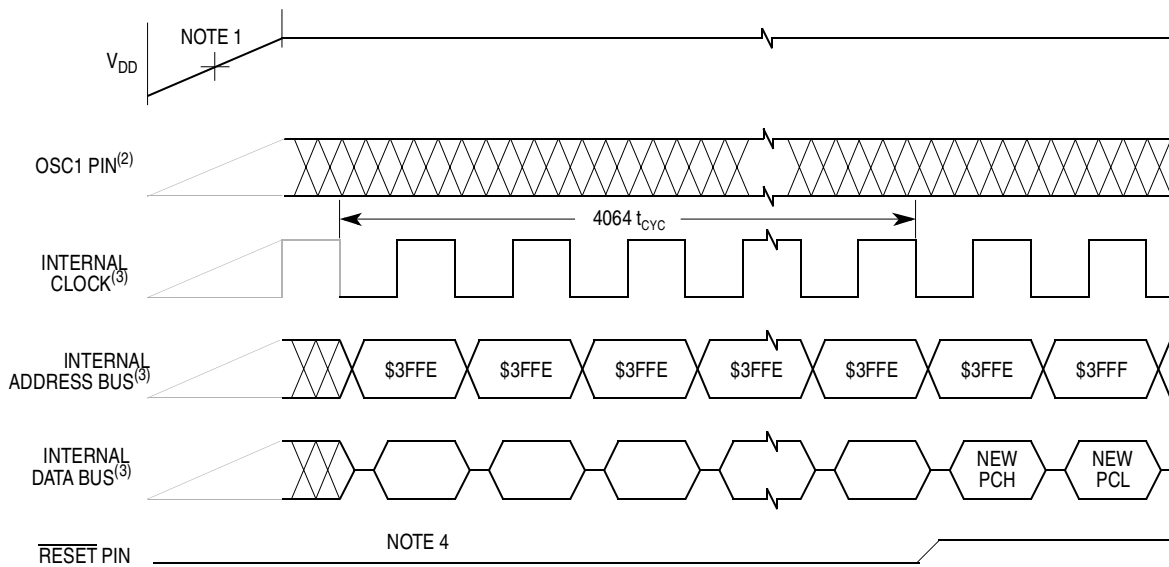

Notes:

1. Power-on reset threshold is typically between 1 V and 2 V.
2. OSC1 line is meant to represent time only, not frequency.
3. Internal clock, internal address bus, and internal data bus are not available externally.
4. RESET outputs  $V_{OL}$  during 4064 POR cycles.

**Figure 12-7. Power-On Reset Timing Diagram**

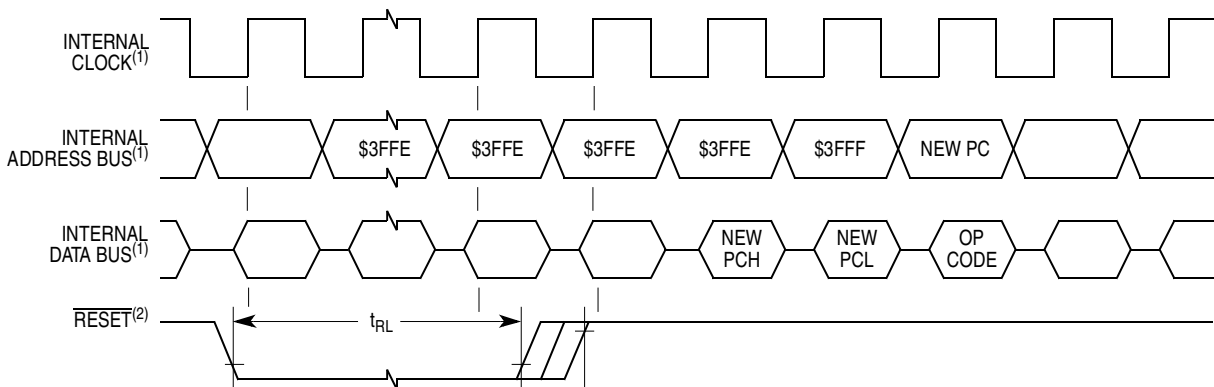

Notes:

1. Internal clock, internal address bus, and internal data bus are not available externally.
2. The next rising edge of the internal clock after the rising edge of RESET initiates the reset sequence.

**Figure 12-8. External Reset Timing**

# Electrical Specifications

## 12.10 5.0-Volt Serial Peripheral Interface Timing

No.	Characteristic <sup>(1)</sup>	Symbol	Min	Max	Unit
	Operating frequency Master Slave	$f_{OP(M)}$ $f_{OP(S)}$	dc dc	0.5 2.1	$f_{OP}$ MHz
1	Cycle time Master Slave	$t_{CYC(M)}$ $t_{CYC(S)}$	2.0 480	— —	$t_{CYC}$ ns
2	Enable lead time Master Slave	$t_{Lead(M)}$ $t_{Lead(S)}$	Note <sup>(2)</sup> 240	— —	ns
3	Enable lag time Master Slave	$t_{Lag(M)}$ $t_{Lag(S)}$	Note <sup>(2)</sup> 720	— —	ns
4	Clock (SCK) high time Master Slave	$t_{W(SCKH)M}$ $t_{W(SCKH)S}$	340 190	— —	ns
5	Clock (SCK) low time Master Slave	$t_{W(SCKL)M}$ $t_{W(SCKL)S}$	340 190	— —	ns
6	Data setup time (inputs) Master Slave	$t_{SU(M)}$ $t_{SU(S)}$	100 100	— —	ns
7	Data hold time (inputs) Master Slave	$t_{H(M)}$ $t_{H(S)}$	100 100	— —	ns
8	Slave access time (time to data active from high-impedance state)	$t_A$	0	120	ns
9	Slave disable time (hold time to high-impedance state)	$t_{DIS}$	—	240	ns
10	Data Valid Master (before capture edge) Slave (after enable edge) <sup>(3)</sup>	$t_{V(M)}$ $t_{V(S)}$	0.25 —	— 240	$t_{CYC(M)}$ ns
11	Data hold time (outputs) Master (after capture edge) Slave (after enable edge)	$t_{HO(M)}$ $t_{HO(S)}$	0.25 0	— —	$t_{CYC(M)}$ ns
12	Rise time (20% $V_{DD}$ to 70% $V_{DD}$ , $C_L = 200$ pF) SPI outputs (SCK, MOSI, and MISO) SPI inputs (SCK, MOSI, MISO, and $\overline{SS}$ )	$t_{RM}$ $t_{RS}$	— —	100 2.0	ns $\mu$ s
13	Fall time (70% $V_{DD}$ to 20% $V_{DD}$ , $C_L = 200$ pF) SPI outputs (SCK, MOSI, and MISO) SPI inputs (SCK, MOSI, MISO, and $\overline{SS}$ )	$t_{FM}$ $t_{FS}$	— —	100 2.0	ns $\mu$ s

1.  $V_{DD} = 5.0$  Vdc  $\pm 10\%$ ;  $V_{SS} = 0$  Vdc,  $T_A = -40$  to  $+125^\circ\text{C}$ , unless otherwise noted. Refer to **Figure 12-9** and **Figure 12-10** for timing diagrams.

2. Signal production depends on software.

3. Assumes 200 pF load on all SPI pins

## 12.11 3.3-Volt Serial Peripheral Interface Timing

No.	Characteristic <sup>(1)</sup>	Symbol	Min	Max	Unit
	Operating frequency Master Slave	$f_{OP(M)}$ $f_{OP(S)}$	dc dc	0.5 1.0	$f_{OP}$ MHz
1	Cycle time Master Slave	$t_{CYC(M)}$ $t_{CYC(S)}$	2.0 1.0	— —	$t_{CYC}$ ns
2	Enable lead time Master Slave	$t_{Lead(M)}$ $t_{Lead(S)}$	Note 2 500	— —	ns
3	Enable lag time Master Slave	$t_{Lag(M)}$ $t_{Lag(S)}$	Note 2 1.5	— —	ns
4	Clock (SCK) high time Master Slave	$t_{W(SCKH)M}$ $t_{W(SCKH)S}$	720 400	— —	ns
5	Clock (SCK) low time Master Slave	$t_{W(SCKL)M}$ $t_{W(SCKL)S}$	720 400	— —	ns
6	Data setup time (inputs) Master Slave	$t_{SU(M)}$ $t_{SU(S)}$	200 200	— —	ns
7	Data hold time (inputs) Master Slave	$t_{H(M)}$ $t_{H(S)}$	200 200	— —	ns
8	Slave access time (time to data active from high-impedance state)	$t_A$	0	250	ns
9	Slave disable time (hold time to high-impedance state)	$t_{DIS}$	—	500	ns
10	Data valid Master (before capture edge) Slave (after enable edge) <sup>(3)</sup>	$t_{V(M)}$ $t_{V(S)}$	0.25 —	— 500	$t_{CYC(M)}$ ns
11	Data hold time (outputs) Master (after capture edge) Slave (after enable edge)	$t_{HO(M)}$ $t_{HO(S)}$	0.25 0	— —	$t_{CYC(M)}$ ns
12	Rise time (20% $V_{DD}$ to 70% $V_{DD}$ , $C_L = 200$ pF) SPI outputs (SCK, MOSI, and MISO) SPI inputs (SCK, MOSI, MISO, and $\overline{SS}$ )	$t_{RM}$ $t_{RS}$	— —	200 2.0	ns $\mu$ s
13	Fall time (70% $V_{DD}$ to 20% $V_{DD}$ , $C_L = 200$ pF) SPI outputs (SCK, MOSI, and MISO) SPI inputs (SCK, MOSI, MISO, and $\overline{SS}$ )	$t_{FM}$ $t_{FS}$	— —	200 2.0	ns $\mu$ s

- $V_{DD} = 3.3 \text{ Vdc} \pm 0.3 \text{ Vdc}$ ;  $V_{SS} = 0 \text{ Vdc}$ ,  $T_A = -40$  to  $+125^\circ\text{C}$ , unless otherwise noted. Refer to **Figure 12-9** and **Figure 12-10** for timing diagrams.
- Signal production depends on software.
- Assumes 200 pF load on all SPI pins

# Electrical Specifications

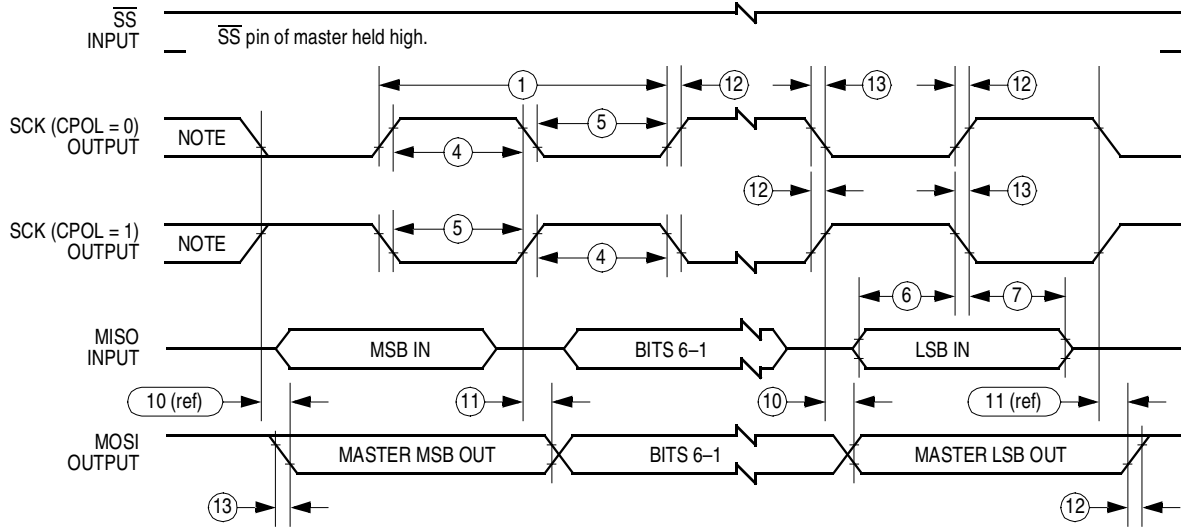

Note: This first clock edge is generated internally, but is not seen at the SCK pin.

## a) SPI Master Timing (CPHA = 0)

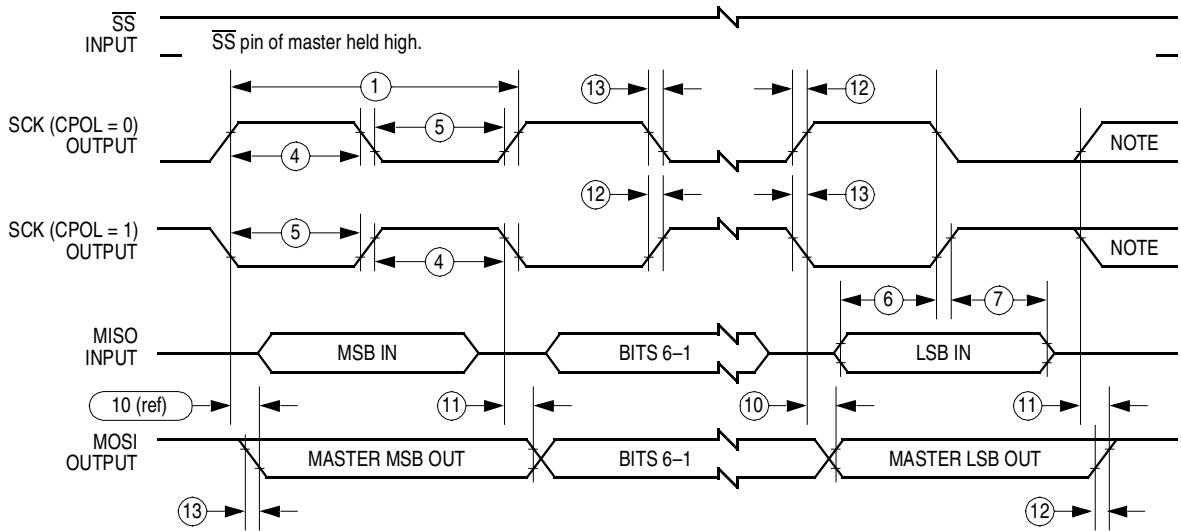

Note: This last clock edge is generated internally, but is not seen at the SCK pin.

## b) SPI Master Timing (CPHA = 1)

Figure 12-9. SPI Master Timing Diagram

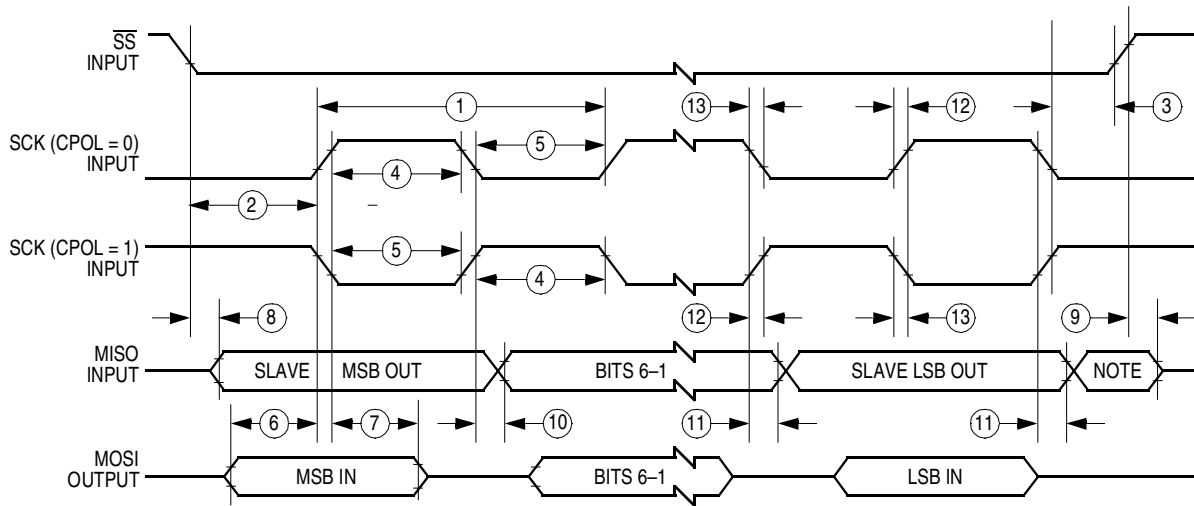

Note: Not defined but normally MSB of character just received

**a) SPI Slave Timing (CPHA = 0)**

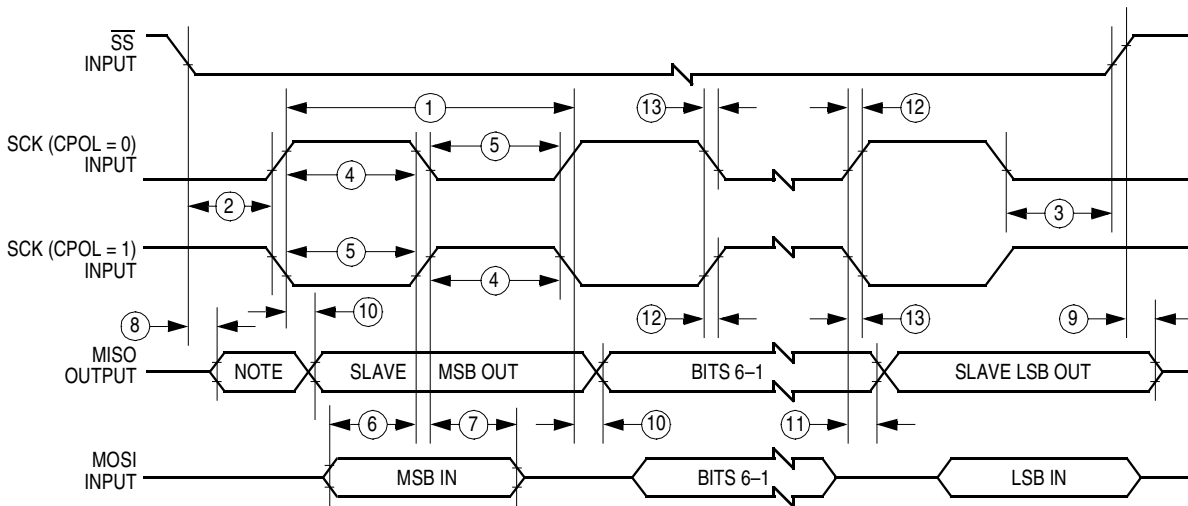

Note: Not defined but normally LSB of character previously transmitted

**a) SPI Slave Timing (CPHA = 1)**

**Figure 12-10. SPI Slave Timing Diagram**





## Section 13. Mechanical Specifications

### 13.1 Contents

13.2	Introduction . . . . .	137
13.3	40-Pin Plastic Dual In-Line (DIP) Package (Case 711-03) . . . . .	138
13.4	42-Pin Plastic Shrink Dual In-Line (SDIP) Package (Case 858-01) . . . . .	138
13.5	44-Lead Plastic-Leaded Chip Carrier (PLCC) (Case 777-02) . . . . .	139
13.6	44-Lead Quad Flat Pack (QFP) (Case 824A-01) . . . . .	140

### 13.2 Introduction

This section describes the dimensions of the plastic dual in-line package (DIP), plastic shrink dual in-line package (SDIP), plastic-leaded chip carrier (PLCC), and quad flat pack (QFP) MCU packages.

Package dimensions available at the time of this publication are provided in this section.

To make sure that you have the latest case outline specifications, contact one of the following:

- Local Motorola Sales Office
- World Wide Web at <http://www.mcu.motsps.com>

Follow World Wide Web on-line instructions to retrieve the current mechanical specifications.

## 13.3 40-Pin Plastic Dual In-Line (DIP) Package (Case 711-03)

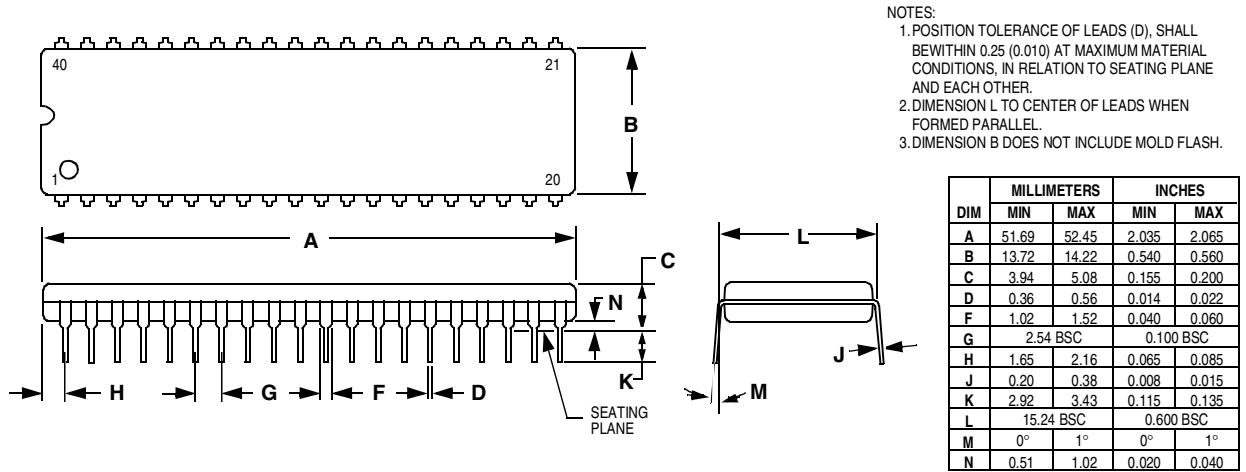

Figure 13-1. 40-Pin Plastic DIP Package (Case 711-03)

## 13.4 42-Pin Plastic Shrink Dual In-Line (SDIP) Package (Case 858-01)

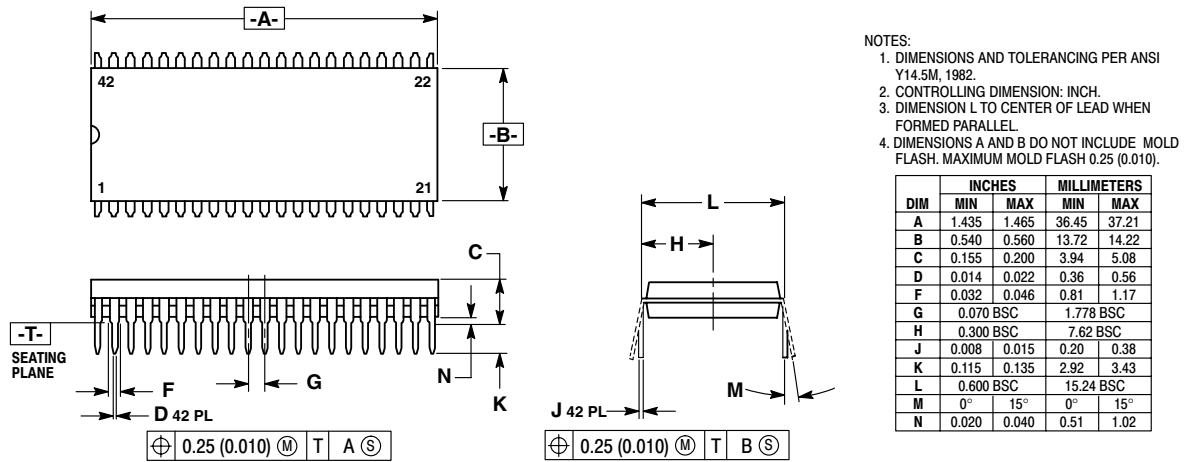
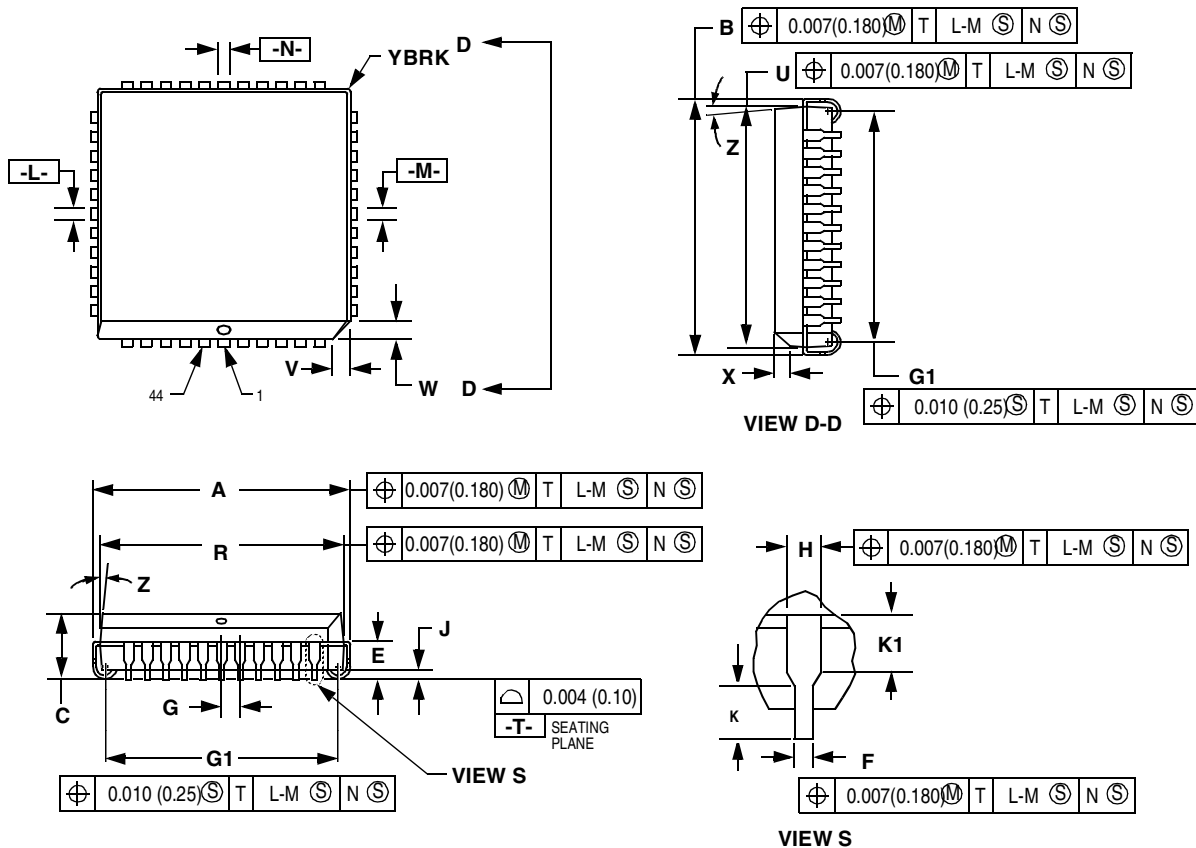

Figure 13-2. 42-Pin Plastic SDIP Package (Case 858-01)

### 13.5 44-Lead Plastic-Leaded Chip Carrier (PLCC) (Case 777-02)



**NOTES:**

- DATUMS  $-L-$ ,  $-M-$ , AND  $-N-$  ARE DETERMINED WHERE TOP OF LEAD SHOULDERS EXITS PLASTIC BODY AT MOLD PARTING LINE.
- DIMENSION  $G1$ , TRUE POSITION TO BE MEASURED AT DATUM  $-T-$ , SEATING PLANE.
- DIMENSION  $R$  AND  $U$  DO NOT INCLUDE MOLD FLASH. ALLOWABLE MOLD FLASH IS 0.010 (0.25) PER SIDE.
- DIMENSIONING AND TOLERANCING PER ANSI Y14.5M, 1982.
- CONTROLLING DIMENSION: INCH.
- THE PACKAGE TOP MAY BE SMALLER THAN THE PACKAGE BOTTOM BY UP TO 0.012 (0.300). DIMENSIONS  $R$  AND  $U$  ARE DETERMINED AT THE OUTERMOST EXTREMES OF THE PLASTIC BODY EXCLUSIVE OF THE MOLD FLASH, TIE BAR BURRS, GATE BURRS AND INTERLEAD FLASH, BUT INCLUDING ANY MISMATCH BETWEEN THE TOP AND BOTTOM OF THE PLASTIC BODY.
- DIMENSION  $H$  DOES NOT INCLUDE DAMBAR PROTRUSION OR INTRUSION. THE DAMBAR PROTRUSION(S) SHALL NOT CAUSE THE  $H$  DIMENSION TO BE GREATER THAN 0.037 (0.940140). THE DAMBAR INTRUSION(S) SHALL NOT CAUSE THE  $H$  DIMENSION TO BE SMALLER THAN 0.025 (0.635).

DIM	INCHES		MILLIMETERS	
	MIN	MAX	MIN	MAX
A	0.685	0.695	17.40	17.65
B	0.685	0.695	17.40	17.65
C	0.165	0.180	4.20	4.57
E	0.090	0.110	2.29	2.79
F	0.013	0.019	0.33	0.48
G	0.050 BSC		1.27 BSC	
H	0.026	0.032	0.66	0.81
J	0.020	—	0.51	—
K	0.025	—	0.64	—
R	0.650	0.656	16.51	16.66
U	0.650	0.656	16.51	16.66
V	0.042	0.048	1.07	1.21
W	0.042	0.048	1.07	1.21
X	0.042	0.056	1.07	1.42
Y	—	0.020	—	0.50
Z	2°	10°	2°	10°
G1	0.610	0.630	15.50	16.00
K1	0.040	—	1.02	—

**Figure 13-3. 44-Lead PLCC (Case 777-02)**

## 13.6 44-Lead Quad Flat Pack (QFP) (Case 824A-01)

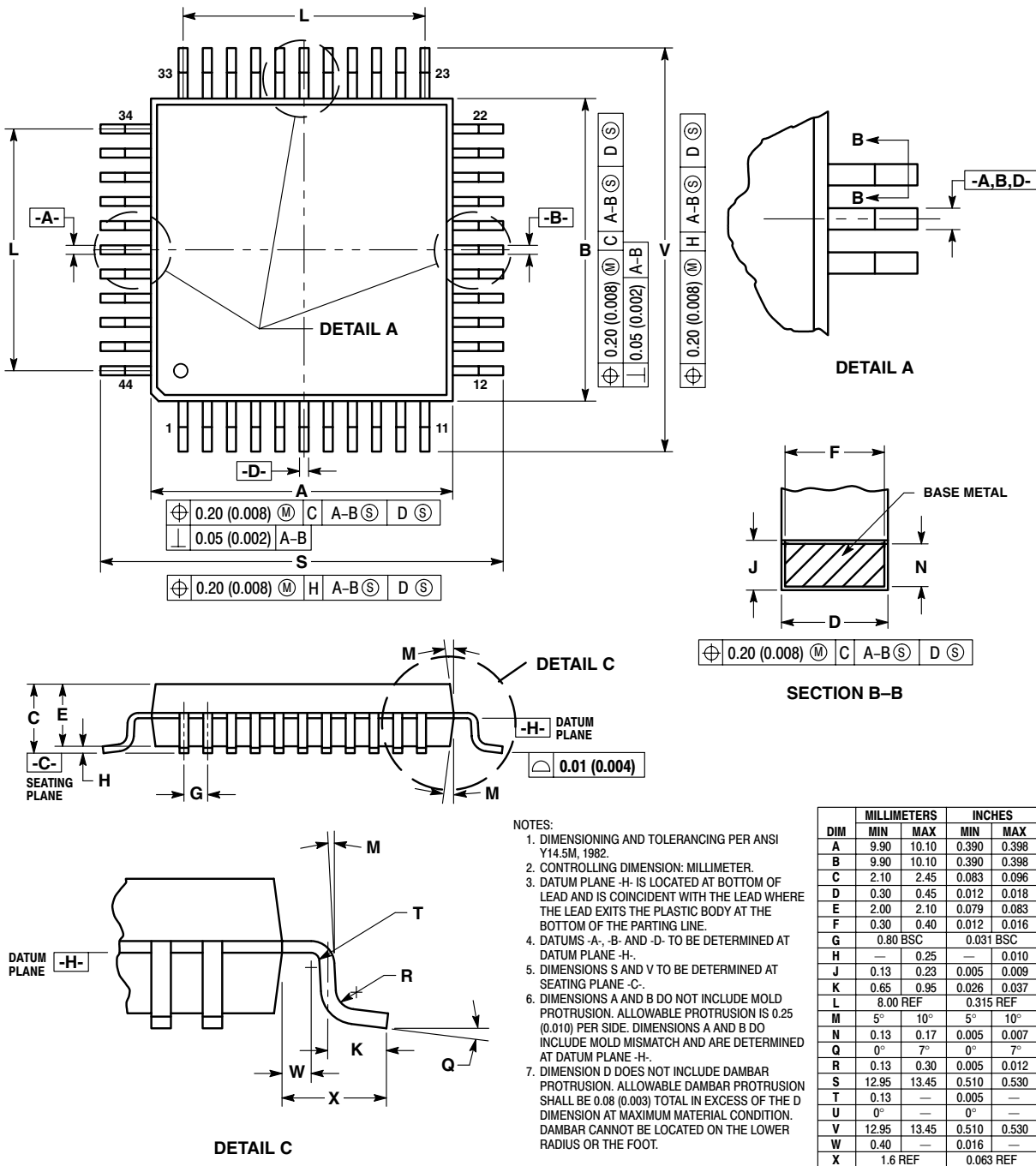

Figure 13-4. 44-Lead QFP (Case 824A-01)

## Section 14. Ordering Information

### 14.1 Contents

14.2	Introduction . . . . .	141
14.3	MC Order Numbers . . . . .	141

### 14.2 Introduction

This section contains ordering information for the available package types.

### 14.3 MC Order Numbers

Table 14-1 shows the MC order numbers for the available package types.

**Table 14-1. MC Order Numbers**

Package Type	Temperature Range	Order Number
40-pin plastic dual in-line package (DIP)	0°C to 70°C	MC68HC05C9AP
	-40°C to 125°C	MC68HC05C9AMP
42-pin shrink dual in-line package (SDIP)	0°C to 70°C	MC68HC05C9AB
	-40°C to 125°C	MC68HC05C9AMB
44-lead plastic-leaded chip carrier (PLCC)	0°C to 70°C	MC68HC05C9AFN
	-40°C to 125°C	MC68HC05C9AMFN
44-pin quad flat pack (QFP)	0°C to 70°C	MC68HC05C9AFB
	-40°C to 125°C	MC68HC05C9AMFB

1. P = Plastic dual in-line package (PDIP)
2. B = Shrink dual in-line package (SDIP)
3. FN = Plastic-leaded chip carrier (PLCC)
4. FB = Quad flat pack (QFP)

## Ordering Information

## Appendix A. MC68HCL05C9A

### A.1 Contents

A.2	Introduction . . . . .	143
A.3	Operating Temperature . . . . .	143
A.4	DC Electrical Characteristics . . . . .	144
A.4.1	1.8–2.4-Volt Low-Power Output Voltage . . . . .	144
A.4.2	1.8–2.4-Volt Input Pullup Current . . . . .	144
A.4.3	2.5–3.6-Volt Low-Power Output Voltage . . . . .	145
A.4.4	2.6–3.6-Volt Input Pullup Current . . . . .	145
A.4.5	Low-Power Supply Current . . . . .	146

### A.2 Introduction

Appendix A describes the MC68HCL05C9A, a low-power version of the MC68HC05C9A. The technical data applying to the MC68HC05C9A applies to the MC68HCL05C9 with the exceptions given in this appendix.

### A.3 Operating Temperature

The data shown here replaces the corresponding data in 12.3 Operating Temperature.

Rating	Symbol	Value	Unit
Operating temperature range MC68HCL05C9AP, FN, B, FB <sup>(1)</sup>	$T_A$	$T_L$ to $T_H$ 0 to +70	°C

1. P = Plastic dual in-line package (PDIP)  
 FN = Plastic-leaded chip carrier (PLCC)  
 B = Shrink dual in-line package (SDIP)  
 FB = Quad flat pack (QFP)

## A.4 DC Electrical Characteristics

The data in 12.6 5.0-Volt DC Electrical Characteristics and 12.7 3.3-Volt DC Electrical Characteristics applies to the MC68HCL05C9A with the exceptions given here.

### A.4.1 1.8–2.4-Volt Low-Power Output Voltage

Characteristic <sup>(1)</sup>	Symbol	Min	Typ	Max	Unit
Output high voltage ( $I_{Load} = -0.1$ mA) PA7–PA0, PB7–PB0, PC6–PC0, TCMP, PD7, PD0 ( $I_{Load} = -0.2$ mA) PD5–PD1 ( $I_{Load} = -0.75$ mA) PC7	$V_{OH}$	$V_{DD} - 0.3$ $V_{DD} - 0.3$ $V_{DD} - 0.3$	— — —	— — —	V
Output low voltage ( $I_{Load} = 0.2$ mA) PA7–PA0, PB7–PB0, PC6–PC0, PD7, PD5–PD0, TCMP ( $I_{Load} = 2.0$ mA) PC7	$V_{OL}$	— —	— —	0.3 0.3	V

1.  $V_{DD} = 1.8$ – $2.4$  Vdc

### A.4.2 1.8–2.4-Volt Input Pullup Current

Characteristic <sup>(1)</sup>	Symbol	Min	Typ	Max	Unit
Input pullup current PB7–PB0 (with pullup)	$I_{In}$	0.45	1.5	6.5	$\mu$ A

1.  $V_{DD} = 1.8$ – $2.4$  Vdc



### A.4.3 2.5–3.6-Volt Low-Power Output Voltage

Characteristic	Symbol	Min	Typ	Max	Unit
Output high voltage <sup>(1)</sup> ( $I_{Load} = -0.2$ mA) PA7–PA0, PB7–PB0, PC6–PC0, TCMP, PD7, PD0 ( $I_{Load} = -0.4$ mA) PD5–PD1 ( $I_{Load} = -1.5$ mA) PC7	$V_{OH}$	$V_{DD} - 0.3$ $V_{DD} - 0.3$ $V_{DD} - 0.3$	— — —	— — —	V
Output low voltage ( $I_{LOAD} = 0.4$ mA) PA7–PA0, PB7–PB0, PC6–PC0, PD7, PD5–PD0, TCMP ( $I_{LOAD} = 5.0$ mA) PC7	$V_{OL}$	— —	— —	0.3 0.3	V

1.  $V_{DD} = 2.5\text{--}3.6$  Vdc

### A.4.4 2.6–3.6-Volt Input Pullup Current

Characteristic <sup>(1)</sup>	Symbol	Min	Typ	Max	Unit
Input pullup current PB7–PB0 (with pullup)	$I_{In}$	1	5	16	$\mu\text{A}$

1.  $V_{DD} = 2.5\text{--}3.6$  Vdc

## A.4.5 Low-Power Supply Current

Characteristic <sup>(1)</sup>	Symbol	Min	Typ	Max	Unit
Supply current (4.5–5.5 Vdc @ $f_{BUS} = 2.1$ MHz)	$I_{DD}$	—	3.5	4.25	mA
Run <sup>(2)</sup>					
Wait <sup>(3)</sup>					
Stop <sup>(4)</sup>					
25 °C					
0 °C to +70 °C (standard)	—	1	15	μA	
0 °C to +70 °C (standard)	—	2	25	μA	
Supply current (2.4–3.6 Vdc @ $f_{BUS} = 1.0$ MHz)	$I_{DD}$	—	1.00	1.4	mA
Run <sup>(2)</sup>					
Wait <sup>(3)</sup>					
Stop <sup>(4)</sup>					
25 °C					
0 °C to +70 °C (standard)	—	1	5	μA	
0 °C to +70 °C (standard)	—	1	10	μA	
Supply current (2.5–3.6 Vdc @ $f_{BUS} = 500$ kHz)	$I_{DD}$	—	500	750	μA
Run <sup>(2)</sup>					
Wait <sup>(3)</sup>					
Stop <sup>(4)</sup>					
25 °C					
0 °C to +70 °C (standard)	—	1	5	μA	
0 °C to +70 °C (standard)	—	1	10	μA	
Supply current (1.8–2.4 Vdc @ $f_{BUS} = 500$ kHz)	$I_{DD}$	—	300	600	μA
Run <sup>(2)</sup>					
Wait <sup>(3)</sup>					
Stop <sup>(4)</sup>					
25 °C					
0 °C to +70 °C (standard)	—	1	2	μA	
0 °C to +70 °C (standard)	—	1	5	μA	

1. Typical values reflect measurements taken on average processed devices at the midpoint of voltage range, 25°C only.
2. Run (operating)  $I_{DD}$  measured using external square wave clock source; all I/O pins configured as inputs, port B =  $V_{DD}$ , all other inputs  $V_{IL} = 0.2$  V,  $V_{IH} = V_{DD} - 0.2$  V; no DC loads; less than 50 pF on all outputs;  $C_L = 20$  pF on OSC2
3. Wait  $I_{DD}$  measured using external square wave clock source; all I/O pins configured as inputs, port B =  $V_{DD}$ , all other inputs  $V_{IL} = 0.2$  V,  $V_{IH} = V_{DD} - 0.2$  V; no DC loads; less than 50 pF on all outputs;  $C_L = 20$  pF on OSC2. Wait  $I_{DD}$  is affected linearly by the OSC2 capacitance.
4. Stop  $I_{DD}$  measured with OSC1 = 0.2 V; all I/O pins configured as inputs, Port B =  $V_{DD}$ , all other inputs  $V_{IL} = 0.2$  V,  $V_{IH} = V_{DD} - 0.2$  V

## Appendix B. MC68HSC05C9A

### B.1 Contents

B.2	Introduction . . . . .	147
B.3	Operating Temperature . . . . .	148
B.4	DC Electrical Characteristics . . . . .	149
B.4.1	High-Speed Supply Current . . . . .	149
B.4.2	Input Pullup Current . . . . .	149
B.5	Control Timing . . . . .	150
B.5.1	4.5–5.5-Volt High-Speed Control Timing . . . . .	150
B.5.2	2.4–3.6-Volt High-Speed Control Timing . . . . .	151
B.5.3	4.5–5.5-Volt High-Speed Control Timing . . . . .	152
B.5.4	2.4–3.6-Volt High-Speed SPI Timing . . . . .	153

### B.2 Introduction

Appendix B describes the MC68HSC05C9A, a high-speed version of the MC68HC05C9A. The technical data applying to the MC68HC05C9A applies to the MC68HSC05C9A with the exceptions given in this appendix.

### B.3 Operating Temperature

The data shown here replaces the corresponding data in 12.3 Operating Temperature.

**Table B-1. High-Speed Operating Temperature Range**

Rating	Symbol	Value	Unit
Operating temperature range <sup>(1)</sup> MC68HSC05C9AP, FN, B, FB MC68HSC05C9ACP, CFN, CB, CFB	$T_A$	$T_L$ to $T_H$ 0 to +70 -40 to +85	°C

1. P = Plastic dual in-line package (PDIP)  
FN = Plastic-leaded chip carrier (PLCC)  
C = Extended temperature range (-40°C to +85°C)  
B = Shrink dual in-line package (SDIP)  
FB = Quad flat pack (QFP)

## B.4 DC Electrical Characteristics

The data in 12.6 5.0-Volt DC Electrical Characteristics and 12.7 3.3-Volt DC Electrical Characteristics applies to the MC68HSC05C9A with the exceptions given here.

### B.4.1 High-Speed Supply Current

Characteristic <sup>(1)</sup>	Symbol	Min	Typ	Max	Unit
Supply current (4.5–5.5 Vdc @ $f_{\text{BUS}} = 4.0 \text{ MHz}$ )					
Run <sup>(2)</sup>	$I_{\text{DD}}$	—	7.00	11.0	mA
Wait <sup>(3)</sup>		—	2.00	6.50	mA
Stop <sup>(4)</sup>		—	1	20	$\mu\text{A}$
25°C		—	1.0	40	$\mu\text{A}$
0°C to 70°C (standard)		—	7.0	50	$\mu\text{A}$
–40°C to 85°C (standard)					
Supply current (2.4–3.6 Vdc @ $f_{\text{BUS}} = 2.0 \text{ MHz}$ )					
Run <sup>(2)</sup>	$I_{\text{DD}}$	—	2.50	4.00	mA
Wait <sup>(3)</sup>		—	1.00	2.00	mA
Stop <sup>(4)</sup>		—	1	8	$\mu\text{A}$
25°C		—	1.0	16	$\mu\text{A}$
0°C to 70°C (standard)		—	2.5	20	$\mu\text{A}$
–40°C to 85°C (standard)					

1. Typical values reflect measurements taken on average processed devices at the midpoint of voltage range, 25°C only.
2. Run (operating)  $I_{\text{DD}}$  measured using external square wave clock source; all I/O pins configured as inputs, port B =  $V_{\text{DD}}$ , all other inputs  $V_{\text{IL}} = 0.2 \text{ V}$ ,  $V_{\text{IH}} = V_{\text{DD}} - 0.2 \text{ V}$ ; no dc loads; less than 50 pF on all outputs;  $C_{\text{L}} = 20 \text{ pF}$  on OSC2
3. Wait  $I_{\text{DD}}$  measured using external square wave clock source; all I/O pins configured as inputs, Port B =  $V_{\text{DD}}$ , all other inputs  $V_{\text{IL}} = 0.2 \text{ V}$ ,  $V_{\text{IH}} = V_{\text{DD}} - 0.2 \text{ V}$ ; no dc loads; less than 50 pF on all outputs;  $C_{\text{L}} = 20 \text{ pF}$  on OSC2. Wait  $I_{\text{DD}}$  is affected linearly by the OSC2 capacitance
4. Stop  $I_{\text{DD}}$  measured with OSC1 = 0.2 V; all I/O pins configured as inputs, port B =  $V_{\text{DD}}$ , all other inputs  $V_{\text{IL}} = 0.2 \text{ V}$ ,  $V_{\text{IH}} = V_{\text{DD}} - 0.2 \text{ V}$

### B.4.2 Input Pullup Current

Characteristic	Symbol	Min	Typ	Max	Unit
Input pullup current ( $V_{\text{DD}} = 4.5\text{--}5.5 \text{ V}$ ) PB7–PB0 (with pullup)	$I_{\text{In}}$	5	15	60	$\mu\text{A}$
Input pullup current ( $V_{\text{DD}} = 2.4\text{--}3.6 \text{ V}$ ) PB7–PB0 (with pullup)	$I_{\text{In}}$	1	5	16	$\mu\text{A}$

## B.5 Control Timing

The data in 12.8 5.0-Volt Control Timing and 12.9 3.3-Volt Control Timing applies to the MC68HSC05C9A with the exceptions given here.

### B.5.1 4.5–5.5-Volt High-Speed Control Timing

Characteristic <sup>(1)</sup>	Symbol	Min	Max	Unit
Oscillator frequency Crystal External clock	$f_{OSC}$	— dc	8.2 8.2	MHz
Internal operating frequency ( $f_{OSC} \div 2$ ) Crystal External clock	$f_{OP}$	— dc	4.1 4.1	MHz
Cycle time	$t_{cyc}$	244	—	ns
Crystal oscillator startup time	$t_{OXOV}$		100	ms
Stop recovery startup time	$t_{ILCH}$		100	ms
$\overline{RESET}$ pulse width	$t_{RL}$	1.5	—	$t_{cyc}$
Timer Resolution <sup>(2)</sup> Input capture pulse width Input capture pulse width	$t_{RESL}$ $t_{TH}$ or $t_{TL}$ $t_{THTL}$	4.0 64 Note <sup>(3)</sup>	— — —	$t_{cyc}$ ns $t_{cyc}$
Interrupt pulse width low (edge-triggered)	$t_{LILH}$	64	—	ns
Interrupt pulse period	$t_{LIL}$	Note <sup>(4)</sup>	—	$t_{cyc}$
OSC1 pulse width	$t_{OH}$ or $t_{OL}$	50	—	ns

1.  $V_{DD} = 4.5\text{--}5.5$  Vdc

2. Because a 2-bit prescaler in the timer must count four internal cycles ( $t_{cyc}$ ), this is the limiting minimum factor in determining the timer resolution.

3. The minimum period  $t_{TLTL}$  should not be less than the number of cycle times it takes to execute the capture interrupt service routine plus  $24 t_{cyc}$ .

4. The minimum  $t_{LIL}$  should not be less than the number of cycle times it takes to execute the interrupt service routine plus  $19 t_{cyc}$ .

## B.5.2 2.4–3.6-Volt High-Speed Control Timing

Characteristic <sup>(1)</sup>	Symbol	Min	Max	Unit
Oscillator frequency Crystal External Clock	$f_{OSC}$	— dc	4.2 4.2	MHz
Internal operating frequency ( $f_{OSC} \div 2$ ) Crystal External clock	$f_{OP}$	— dc	2.1 2.1	MHz
Cycle time	$t_{cyc}$	480	—	ns
Crystal oscillator startup time	$t_{OXOV}$	—	100	ms
Stop recovery startup time	$t_{ILCH}$	—	100	ms
$\overline{RESET}$ pulse width	$t_{RL}$	1.5	—	$t_{cyc}$
Timer Resolution <sup>(2)</sup> Input capture pulse width Input capture pulse width	$t_{RESL}$ $t_{TH}$ or $t_{TL}$ $t_{THTL}$	4.0 125 Note <sup>(3)</sup>	— — —	$t_{cyc}$ ns $t_{cyc}$
Interrupt pulse width low (edge-triggered)	$t_{LIH}$	125	—	ns
Interrupt pulse period	$t_{LIL}$	Note <sup>(4)</sup>	—	$t_{cyc}$
OSC1 pulse width	$t_{OH}$ or $t_{OL}$	90	—	ns

1.  $V_{DD} = 2.4\text{--}3.6$  Vdc

2. Because a 2-bit prescaler in the timer must count four internal cycles ( $t_{cyc}$ ), this is the limiting minimum factor in determining the timer resolution.

3. The minimum period  $t_{THTL}$  should not be less than the number of cycle times it takes to execute the capture interrupt service routine plus  $24 t_{cyc}$ .

4. The minimum  $t_{LIL}$  should not be less than the number of cycle times it takes to execute the interrupt service routine plus  $19 t_{cyc}$ .

**B.5.3 4.5–5.5-Volt High-Speed Control Timing**

Num	Characteristic <sup>(1)</sup>	Symbol	Min	Max	Unit
	Operating frequency Master Slave	$f_{OP(M)}$ $f_{OP(S)}$	dc dc	0.5 4.1	$f_{OP}$ MHz
1	Cycle time Master Slave	$t_{cyc(M)}$ $t_{cyc(S)}$	2.0 244	— —	$t_{cyc}$ ns
2	Enable lead time Master Slave	$t_{Lead(M)}$ $t_{Lead(S)}$	Note <sup>(2)</sup> 122	— —	ns
3	Enable lag time Master Slave	$t_{Lag(M)}$ $t_{Lag(S)}$	Note <sup>(2)</sup> 366	— —	ns
4	Clock (SCK) high time Master Slave	$t_{W(SCKH)M}$ $t_{W(SCKH)S}$	166 93	— —	ns
5	Clock (SCK) low time Master Slave	$t_{W(SCKL)M}$ $t_{W(SCKL)S}$	166 93	— —	ns
6	Data setup time (inputs) Master Slave	$t_{SU(M)}$ $t_{SU(S)}$	49 49	— —	ns
7	Data hold time (inputs) Master Slave	$t_{H(M)}$ $t_{H(S)}$	49 49	— —	ns
8	Slave access time (time to data active from high-impedance state)	$t_A$	0	61	ns
9	Slave disable time (hold time to high-impedance state)	$t_{DIS}$	—	122	ns
10	Data valid Master (before capture edge) Slave (after enable edge) <sup>(3)</sup>	$t_{V(M)}$ $t_{V(S)}$	0.25 —	— 122	$t_{cyc(M)}$ ns
11	Data hold time (outputs) Master (after capture edge) Slave (after enable edge)	$t_{HO(M)}$ $t_{HO(S)}$	0.25 0	— —	$t_{cyc(M)}$ ns
12	Rise time (20% $V_{DD}$ to 70% $V_{DD}$ , $C_L = 200$ pF) SPI outputs (SCK, MOSI, and MISO) SPI inputs (SCK, MOSI, MISO, and $\overline{SS}$ )	$t_{RM}$ $t_{RS}$	— —	50 1.0	ns $\mu$ s
13	Fall time (70% $V_{DD}$ to 20% $V_{DD}$ , $C_L = 200$ pF) SPI outputs (SCK, MOSI, and MISO) SPI inputs (SCK, MOSI, MISO, and $\overline{SS}$ )	$t_{FM}$ $t_{FS}$	— —	50 1.0	ns $\mu$ s

1.  $V_{DD} = 4.5\text{--}5.5$  Vdc
2. Signal production depends on software.
3. Assumes 200 pF load on all SPI pins



### B.5.4 2.4–3.6-Volt High-Speed SPI Timing

Num	Characteristic <sup>(1)</sup>	Symbol	Min	Max	Unit
	Operating frequency Master Slave	$f_{OP(M)}$ $f_{OP(S)}$	dc dc	0.5 2.1	$f_{OP}$ MHz
1	Cycle time Master Slave	$t_{cyc(M)}$ $t_{cyc(S)}$	2.0 480	— —	$t_{cyc}$ ns
2	Enable lead time Master Slave	$t_{Lead(M)}$ $t_{Lead(S)}$	Note <sup>(2)</sup> 240	— —	ns
3	Enable lag time Master Slave	$t_{Lag(M)}$ $t_{Lag(S)}$	Note <sup>(2)</sup> 720	— —	ns
4	Clock (SCK) high time Master Slave	$t_{W(SCKH)M}$ $t_{W(SCKH)S}$	340 190	— —	ns
5	Clock (SCK) low time Master Slave	$t_{W(SCKL)M}$ $t_{W(SCKL)S}$	340 190	— —	ns
6	Data setup time (inputs) Master Slave	$t_{SU(M)}$ $t_{SU(S)}$	100 100	— —	ns
7	Data hold time (inputs) Master Slave	$t_{H(M)}$ $t_{H(S)}$	100 100	— —	ns
8	Slave access time (time to data active from high-impedance state)	$t_A$	0	120	ns
9	Slave disable time (hold time to high-impedance state)	$t_{DIS}$	—	240	ns
10	Data valid Master (before capture edge) Slave (after enable edge) <sup>(3)</sup>	$t_{V(M)}$ $t_{V(S)}$	0.25 —	— 240	$t_{cyc(M)}$ ns
11	Data hold time (outputs) Master (after capture edge) Slave (after enable edge)	$t_{HO(M)}$ $t_{HO(S)}$	0.25 0	— —	$t_{cyc(M)}$ ns
12	Rise time (20% $V_{DD}$ to 70% $V_{DD}$ , $C_L = 200$ pF) SPI outputs (SCK, MOSI, and MISO) SPI inputs (SCK, MOSI, MISO, and $\overline{SS}$ )	$t_{RM}$ $t_{RS}$	— —	100 2.0	ns $\mu$ s
13	Fall time (70% $V_{DD}$ to 20% $V_{DD}$ , $C_L = 200$ pF) SPI outputs (SCK, MOSI, and MISO) SPI inputs (SCK, MOSI, MISO, and $\overline{SS}$ )	$t_{FM}$ $t_{FS}$	— —	100 2.0	ns $\mu$ s

1.  $V_{DD} = 2.4\text{--}3.6$  Vdc

2. Signal production depends on software.

3. Assumes 200 pF load on all SPI pins



## **Appendix C. Self-Check Mode**

### **C.1 Contents**

C.2	Introduction . . . . .	155
C.3	Self-Check Mode . . . . .	156
C.3.1	Self-Check Tests . . . . .	156
C.3.2	Self-Check Results . . . . .	158

### **C.2 Introduction**

This appendix describes the self-check mode.

### C.3 Self-Check Mode

Self-check mode is entered upon the rising edge of  $\overline{\text{RESET}}$  if the  $\overline{\text{IRQ}}$  pin is at  $V_{\text{tst}}$  and the TCAP pin is at logic 1.

#### C.3.1 Self-Check Tests

The self-check read-only memory (ROM) at mask ROM location \$3F00–\$3FEF determines if the microcontroller unit (MCU) is functioning properly.

These tests are performed:

1. Input/output (I/O) — Functional test of ports A, B, and C
2. Random-access memory (RAM) — Counter test for each RAM byte
3. Timer — Test of counter register and OCF bit
4. Serial communications interface (SCI) — Transmission test; checks for RDRF, TDRE, TC, and FE flags
5. ROM — Exclusive OR with odd ones parity result
6. Serial peripheral interface (SPI) — Transmission test; checks for SPIF and WCOL flags

The self-check circuit is shown in **Figure C-1**.

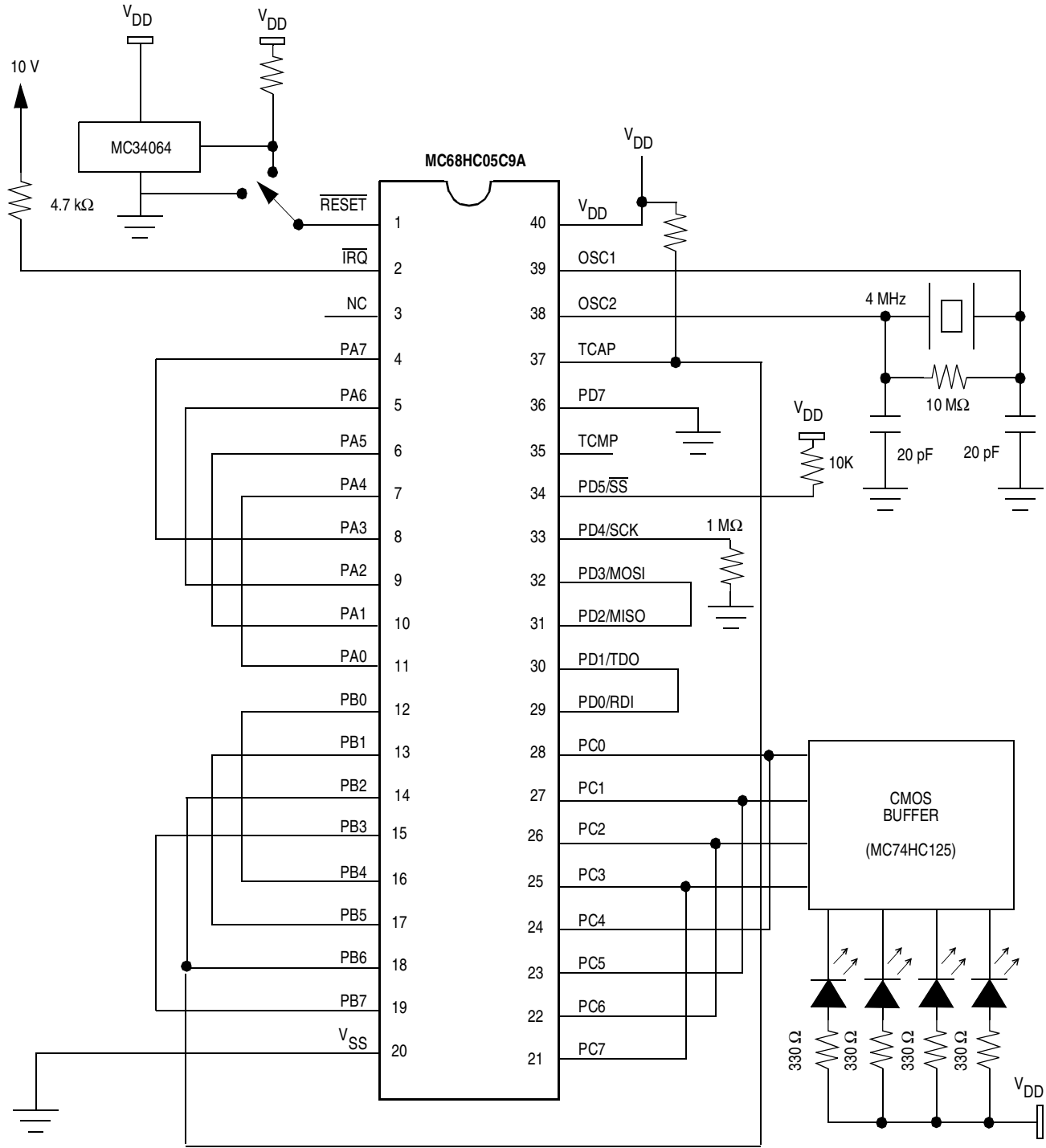

- Notes:
1.  $V_{DD} = 5.0\text{ V}$
  2. TCMP = NC

**Figure C-1. Self-Check Circuit Schematic**

## C.3.2 Self-Check Results

Table C-1 shows the LED codes that indicate self-check test results.

**Table C-1. Self-Check Circuit LED Codes**

PC3	PC2	PC1	PC0	Remarks
Off	On	On	Off	I/O failure
Off	On	Off	On	RAM failure
Off	On	Off	Off	Timer failure
Off	Off	On	On	SCI failure
Off	Off	On	Off	ROM failure
Off	Off	Off	On	SPI failure
Flashing				No failure
All others				Device failure

Perform these steps to activate the self-check tests:

1. Apply 10 V ( $2 \times V_{DD}$ ) to the  $\overline{\text{IRQ}}$  pin.
2. Apply a logic 1 to the TCAP pin.
3. Apply a logic 0 to the  $\overline{\text{RESET}}$  pin.

The self-check tests begin on the rising edge of the  $\overline{\text{RESET}}$  pin.

$\overline{\text{RESET}}$  must be held low for 4064 cycles after power-on reset (POR), or for a time,  $t_{RL}$ , for any other reset. For the value of  $t_{RL}$ , see 12.8 5.0-Volt Control Timing and 12.9 3.3-Volt Control Timing.

## Appendix D. M68HC05Cx Family Feature Comparisons

Refer to **Table D-1** for a comparison of the features for all the M68HC05C Family members.

# M68HC05Cx Family Feature Comparisons

**Table D-1. M68HC05Cx Feature Comparison**

	C4	C4A	705C4A	C8	C8A	705C8	705C8A	C12	C12A	C9	C9A	705C9	705C9A
USER ROM	4160	4160	—	7744	7744	—	—	12,096	12,096	15,760–15,936	15,760–15,936	—	—
USER EPROM	—	—	4160	—	—	7596–7740	7596–7740	—	—	—	—	15,760–15,936	12,096–15,936
CODE SECURITY	NO	YES	YES	NO	YES	YES	YES	NO	YES	NO	YES	NO	YES
RAM	176	176	176	176	176	176–304	176–304	176	176	176–352	176–352	176–352	176–352
OPTION REGISTER (IRQ/RAM/SEC)	NO	NO	\$1FDF (IRQ/SEC)	NO	NO	\$1FDF (IRQ/RAM/SEC)	\$1FDF (IRQ/RAM/SEC)	NO	NO	\$3FDF (IRQ/RAM)	\$3FDF (IRQ/RAM)	\$3FDF (IRQ/RAM)	\$3FDF (IRQ/RAM)
MASK OPTION REGISTER(S)	NO	NO	\$1FF0–\$1FF1	NO	NO	NO	\$1FF0–\$1FF1	NO	NO	NO	NO	NO	\$3FF0–\$3FF1
PORTB KEYSCAN (PULLUP/INTERRUPT)	NO	YES MASK OPTION	YES MOR SELECTABLE	NO	YES MASK OPTION	NO	YES MOR SELECTABLE	YES MASK OPTION	YES MASK OPTION	NO	YES MASK OPTION	NO	YES MOR SELECTABLE
PC7 DRIVE	STANDARD	HIGH CURRENT	HIGH CURRENT	STANDARD	HIGH CURRENT	STANDARD	HIGH CURRENT	HIGH CURRENT	HIGH CURRENT	STANDARD	HIGH CURRENT	STANDARD	HIGH CURRENT
PORT D	PD7, 5–0 INPUT ONLY	PD7, 5–0 INPUT ONLY	PD7, 5–0 INPUT ONLY	PD7, 5–0 INPUT ONLY	PD7, 5–0 INPUT ONLY	PD7, 5–0 INPUT ONLY	PD7, 5–0 INPUT ONLY	PD7, 5–0 INPUT ONLY	PD7, 5–0 INPUT ONLY	PD7, 5–0 BIDIRECTIONAL	PD7, 5–0 BIDIRECTIONAL	PD7, 5–0 BIDIRECTIONAL	PD7, 5–0 BIDIRECTIONAL
COP	NO	YES	YES	NO	YES	YES	TWO TYPES	YES	YES	YES	YES	YES	TWO TYPES
COP ENABLE	—	MASK OPTION	MOR	—	MASK OPTION	SOFTWARE	SOFTWARE+ MOR	MASK OPTION	MASK OPTION	SOFTWARE	SOFTWARE	SOFTWARE	SOFTWARE+ MOR
COP TIMEOUT	—	64 ms (@4 MHz OSC)	64 ms (@4 MHz OSC)	—	64 ms (@4 MHz OSC)	SOFTWARE SELECTABLE	SOFTWARE+ MOR SELECTABLE	64 ms (@4 MHz OSC)	64 ms (@4 MHz OSC)	SOFTWARE SELECTABLE	SOFTWARE SELECTABLE	SOFTWARE SELECTABLE	SOFTWARE+ MOR SELECTABLE
COP CLEAR	—	CLR \$1FF0	CLR \$1FF0	—	CLR \$1FF0	WRITE \$55/\$AA TO \$001D	WRITE \$55/\$AA TO \$001D OR CLR \$1FF0	CLR \$3FF0	CLR \$3FF0	WRITE \$55/\$AA TO \$001D	WRITE \$55/\$AA TO \$001D	WRITE \$55/\$AA TO \$001D	WRITE \$55/\$AA TO \$001D OR CLR \$3FF0
CLOCK MONITOR	NO	NO	NO	NO	NO	YES	YES	NO	NO	YES	YES	YES	YES (C9A MODE)
ACTIVE RESET	NO	NO	NO	NO	NO	COP/CLOCK MONITOR	PROGRAMMABLE COP/CLOCK MONITOR	NO	NO	POR/COP/ CLOCK MONITOR	POR/COP/ CLOCK MONITOR	POR/COP/ CLOCK MONITOR	POR/C9A COP/ CLOCK MONITOR
STOP DISABLE	NO	MASK OPTION	NO	NO	MASK OPTION	NO	NO	MASK OPTION	MASK OPTION	NO	NO	NO	MOR SELECTABLE (C12A MODE)

Notes:

1. The expanded RAM map (from \$30–\$4F and \$100–\$15F) available on the OTP devices MC68HC705C8 and MC68HC705C8A is not available on the ROM devices MC68HC05C8 and MC68HC05C8A.
2. The programmable COP available on the MC68HC705C8 and MC68HC705C8A is not available on the MC68HC05C8A. For ROM compatibility, use the non-programmable COP.





## How to Reach Us:

### **USA/EUROPE/LOCATIONS NOT LISTED:**

Motorola Literature Distribution  
P.O. Box 5405  
Denver, Colorado 80217  
1-303-675-2140  
1-800-441-2447

### **TECHNICAL INFORMATION CENTER:**

1-800-521-6274

### **JAPAN:**

Motorola Japan Ltd.  
SPS, Technical Information Center  
3-20-1, Minami-Azabu, Minato-ku  
Tokyo 106-8573 Japan  
81-3-3440-3569

### **ASIA/PACIFIC:**

Motorola Semiconductors H.K. Ltd.  
Silicon Harbour Centre  
2 Dai King Street  
Tai Po Industrial Estate  
Tai Po, N.T., Hong Kong  
852-26668334

### **HOME PAGE:**

<http://www.motorola.com/semiconductors/>



**MOTOROLA**

**MC68HC05C9A/D  
REV 5**