

### SUMMARY

High performance 32-bit/40-bit floating-point processor optimized for high performance automotive audio processing

Audio decoder and post processor-algorithm support with 32-bit floating-point implementations

Nonvolatile memory may be configured to support audio decoders and post processor-algorithms like PCM, Dolby<sup>®</sup> Digital EX, Dolby Prologic IIx, DTS 96/24, Neo:6, DTS ES<sup>™</sup>, MPEG2 AAC, MPEG2 2-channel, MP3, and functions like bass management, delay, speaker equalization, graphic equalization, and more. Decoder/post-processor algorithm combination support will vary depending upon the chip version and the system configurations. Please visit [www.analog.com/SHARC](http://www.analog.com/SHARC).

Single-instruction, multiple-data (SIMD) computational architecture

On-chip memory—3M bit of on-chip SRAM and a dedicated 4M bit of on-chip ROM

Code-compatible with all other members of the SHARC family

The ADSP-21366 is available with a 333 MHz core instruction rate and unique audiocentric peripherals such as the digital audio interface, S/PDIF transceiver, serial ports, 8-channel asynchronous sample rate converter, precision clock generators and more. For complete ordering information, see [Ordering Guide on Page 53](#).

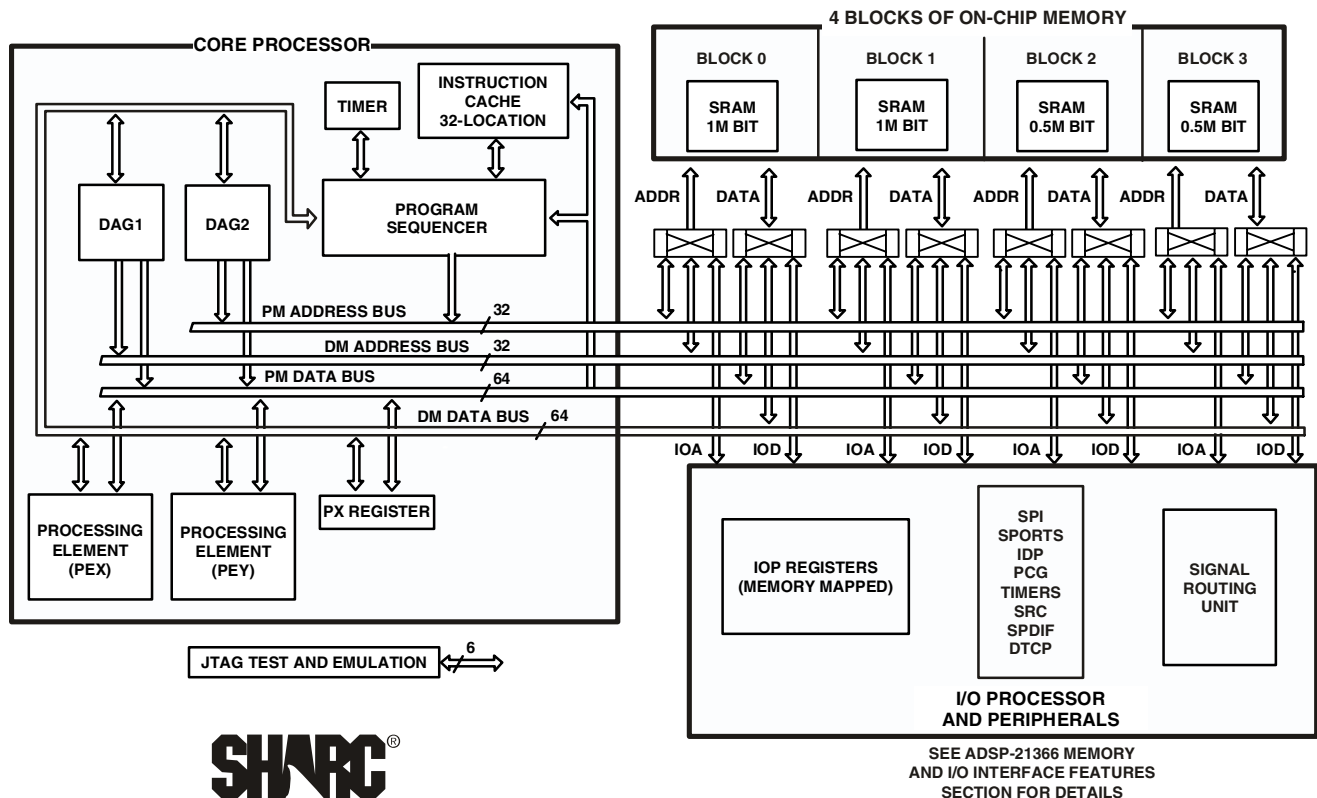

Figure 1. Functional Block Diagram—Processor Core

SHARC and the SHARC logo are registered trademarks of Analog Devices, Inc.

### Rev. 0

Information furnished by Analog Devices is believed to be accurate and reliable. However, no responsibility is assumed by Analog Devices for its use, nor for any infringements of patents or other rights of third parties that may result from its use. Specifications subject to change without notice. No license is granted by implication or otherwise under any patent or patent rights of Analog Devices. Trademarks and registered trademarks are the property of their respective owners.

# ADSP-21366

## KEY FEATURES—PROCESSOR CORE

At 333 MHz (3.0 ns) core instruction rate, the ADSP-21366 performs 2 GFLOPS/666 MMACS

3M bit on-chip SRAM (1M bit in blocks 0 and 1, and 0.50M bit in blocks 2 and 3) for simultaneous access by the core processor and DMA

4M bit on-chip ROM (2M bit in block 0 and 2M bit in block 1)

Dual data address generators (DAGs) with modulo and bit-reverse addressing

Zero-overhead looping with single-cycle loop setup, providing efficient program sequencing

Single-instruction multiple-data (SIMD) architecture provides:

- Two computational processing elements
- Concurrent execution
- Code compatibility with other SHARC family members at the assembly level
- Parallelism in buses and computational units allows single cycle execution (with or without SIMD) of a multiply operation, an ALU operation, a dual memory read or write, and an instruction fetch

Transfers between memory and core at a sustained 5.4G bytes/s bandwidth at 333 MHz core instruction rate

## INPUT/OUTPUT FEATURES

DMA controller supports:

- 25 DMA channels for transfers between ADSP-21366 internal memory and a variety of peripherals
- 32-bit DMA transfers at peripheral clock speed, in parallel with full-speed processor execution

Asynchronous parallel port provides access to asynchronous external memory

- 16 multiplexed address/data lines support 24-bit address external address range with 8-bit data or 16-bit address external address range with 16-bit data
- 55M byte per sec transfer rate

External memory access in a dedicated DMA channel

- 8-bit to 32-bit and 16-bit to 32-bit packing options

Programmable data cycle duration: 2 to 31 CCLK

Digital audio interface (DAI) includes six serial ports, two precision clock generators, an input data port, three timers, an S/PDIF transceiver, an 8-channel asynchronous sample rate converter, an SPI port, and a signal routing unit

Six dual data line serial ports that operate at up to 50M bits/s on each data line—each has a clock, frame sync, and two data lines that can be configured as either a receiver or transmitter pair

Left-justified sample pair and I<sup>2</sup>S support, programmable direction for up to 24 simultaneous receive or transmit channels using two I<sup>2</sup>S-compatible stereo devices per serial port

TDM support for telecommunications interfaces including 128 TDM channel support for newer telephony interfaces such as H.100/H.110

Up to 12 TDM stream support, each with 128 channels per frame

Companding selection on a per channel basis in TDM mode

Input data port provides an additional input path to the processor core, configurable as eight channels of serial data or seven channels of serial data and up to a 20-bit wide parallel data channel

Signal routing unit provides configurable and flexible connections between all DAI components—six serial ports, one SPI port, eight channels of asynchronous sample rate converters, an S/PDIF receiver/transmitter, three timers, an SPI port, 10 interrupts, six flag inputs, six flag outputs, and 20 SRU I/O pins (DAI\_Px)

Two serial peripheral interfaces (SPI): primary on dedicated pins, secondary on DAI pins provide:

- master or slave serial boot through primary SPI, full-duplex operation, master-slave mode multimaster support, open drain outputs, programmable baud rates, clock polarities and phases

3 muxed flag/IRQ lines

1 muxed flag/timer expired line

## DEDICATED AUDIO COMPONENTS

S/PDIF-compatible digital audio receiver/transmitter supports EIAJ CP-340 (CP-1201), IEC-958, AES/EBU standards left-justified, I<sup>2</sup>S, or right-justified serial data input with 16-, 18-, 20-, or 24-bit word widths (transmitter)

- Two channel mode and single channel double frequency (SCDF) mode

Sample rate converter (SRC) contains a serial input port, de-emphasis filter, sample rate converter (SRC) and serial output port providing up to -128dB SNR performance

- Supports left-justified, I<sup>2</sup>S, TDM, and right-justified 24-, 20-, 18- and 16-bit serial formats (input)

Pulse-width modulation provides:

- 16 PWM outputs configured as four groups of four outputs
- Supports center-aligned or edge-aligned PWM waveforms
- Can generate complementary signals on two outputs in paired mode or independent signals in nonpaired mode

ROM-based security features include:

- JTAG access to memory permitted with a 64-bit key
- Protected memory regions that can be assigned to limit access under program control to sensitive code

PLL has a wide variety of software and hardware multiplier/divider ratios

Dual voltage: 3.3 V I/O, 1.2 V, or 1.0 V core

Available in 136-ball BGA package (see [Ordering Guide on Page 53](#))

## CONTENTS

Summary .....	1
Key Features—Processor Core .....	2
Input/Output Features .....	2
Dedicated Audio Components .....	2
General Description .....	4
ADSP-21366 Family Core Architecture .....	4
ADSP-21366 Memory and I/O Interface Features .....	6
Development Tools .....	9
Additional Information .....	11
Pin Function Descriptions .....	12
Address Data Pins as FLAGS .....	15
Address/Data Modes .....	15
Boot Modes .....	15
Core Instruction Rate to CLKIN Ratio Modes .....	15
ADSP-21366 Specifications .....	16
Recommended Operating Conditions .....	16
Electrical Characteristics .....	16
Maximum Power Dissipation .....	17
Absolute Maximum Ratings .....	17
ESD Sensitivity .....	17
Timing Specifications .....	18
Output Drive Currents .....	45
Test Conditions .....	45
Capacitive Loading .....	45
Thermal Characteristics .....	46
136-Ball BGA Pin Configurations .....	47
Outline Dimensions .....	51
Ordering Guide .....	53

## REVISION HISTORY

10/05—Rev 0: Initial Version

# ADSP-21366

## GENERAL DESCRIPTION

The ADSP-21366 SHARC processor is a member of the SIMD SHARC family of DSPs that feature Analog Devices' Super Harvard Architecture. The processor is source code-compatible with the ADSP-2126x, and ADSP-2116x, DSPs as well as with first generation ADSP-2106x SHARC processors in SISD (single-instruction, single-data) mode. The ADSP-21366 is a 32-bit/40-bit floating-point processor optimized for high performance automotive audio applications with a large on-chip SRAM and ROM, multiple internal buses to eliminate I/O bottlenecks, and an innovative digital audio interface (DAI).

As shown in the functional block diagram on Page 1, the ADSP-21366 uses two computational units to deliver a significant performance increase over the previous SHARC processors on a range of signal processing algorithms. Fabricated in a state-of-the-art, high speed, CMOS process, the ADSP-21366 processor achieves an instruction cycle time of 3.0 ns at 333 MHz. With its SIMD computational hardware, the ADSP-21366 can perform two GFLOPS running at 333 MHz.

Table 1 shows performance benchmarks for the processors running at 333 MHz.

**Table 1. Benchmarks (at 333 MHz)**

Benchmark Algorithm	Speed (at 333 MHz)
1024 Point Complex FFT (Radix 4, with reversal)	27.9 $\mu$ s
FIR Filter (per tap) <sup>1</sup>	1.5 ns
IIR Filter (per biquad) <sup>1</sup>	6.0 ns
Matrix Multiply (pipelined) [3 $\times$ 3] $\times$ [3 $\times$ 1]	13.5 ns
[4 $\times$ 4] $\times$ [4 $\times$ 1]	23.9 ns
Divide (y/x)	10.5 ns
Inverse Square Root	16.3 ns

<sup>1</sup> Assumes two files in multichannel SIMD mode

The ADSP-21366 continues SHARC's industry-leading standards of integration for DSPs, combining a high performance 32-bit DSP core with integrated, on-chip system features.

The block diagram of the ADSP-21366 on Page 1, illustrates the following architectural features:

- Two processing elements, each of which comprises an ALU, multiplier, shifter, and data register file
- Data address generators (DAG1, DAG2)
- Program sequencer with instruction cache
- PM and DM buses capable of supporting four 32-bit data transfers between memory and the core at every core processor cycle
- Three programmable interval timers with PWM generation, PWM capture/pulse width measurement, and external event counter capabilities
- On-chip SRAM (3M bit)

- On-chip ROM (4M bit)
- 8- or 16-bit parallel port that supports interfaces to off-chip memory peripherals
- JTAG test access port

The block diagram of the ADSP-21366 on Page 7 illustrates the following architectural features:

- DMA controller
- Six full duplex serial ports
- Two SPI-compatible interface ports—primary on dedicated pins, secondary on DAI pins
- Digital audio interface that includes two precision clock generators (PCG), an input data port (IDP), an S/PDIF receiver/transmitter, eight channels asynchronous sample rate converters, six serial ports, eight serial interfaces, a 20-bit parallel input port, 10 interrupts, six flag outputs, six flag inputs, three timers, and a flexible signal routing unit (SRU)

Figure 2 on Page 5 shows one sample configuration of a SPORT using the precision clock generators to interface with an I<sup>2</sup>S ADC and an I<sup>2</sup>S DAC with a much lower jitter clock than the serial port would generate itself. Many other SRU configurations are possible.

### ADSP-21366 FAMILY CORE ARCHITECTURE

The ADSP-21366 is code-compatible at the assembly level with the ADSP-2126x, ADSP-21160 and ADSP-21161, and with the first generation ADSP-2106x SHARC processors. The ADSP-21366 shares architectural features with the ADSP-2126x and ADSP-2116x SIMD SHARC processors, as detailed in the following sections.

#### SIMD Computational Engine

The ADSP-21366 contains two computational processing elements that operate as a single-instruction multiple-data (SIMD) engine. The processing elements are referred to as PEX and PEY and each contains an ALU, multiplier, shifter, and register file. PEX is always active, and PEY may be enabled by setting the PEYEN mode bit in the MODE1 register. When this mode is enabled, the same instruction is executed in both processing elements, but each processing element operates on different data. This architecture is efficient at executing math intensive signal processing algorithms.

Entering SIMD mode also has an effect on the way data is transferred between memory and the processing elements. When in SIMD mode, twice the data bandwidth is required to sustain computational operation in the processing elements. Because of this requirement, entering SIMD mode also doubles the bandwidth between memory and the processing elements. When using the DAGs to transfer data in SIMD mode, two data values are transferred with each access of memory or the register file.

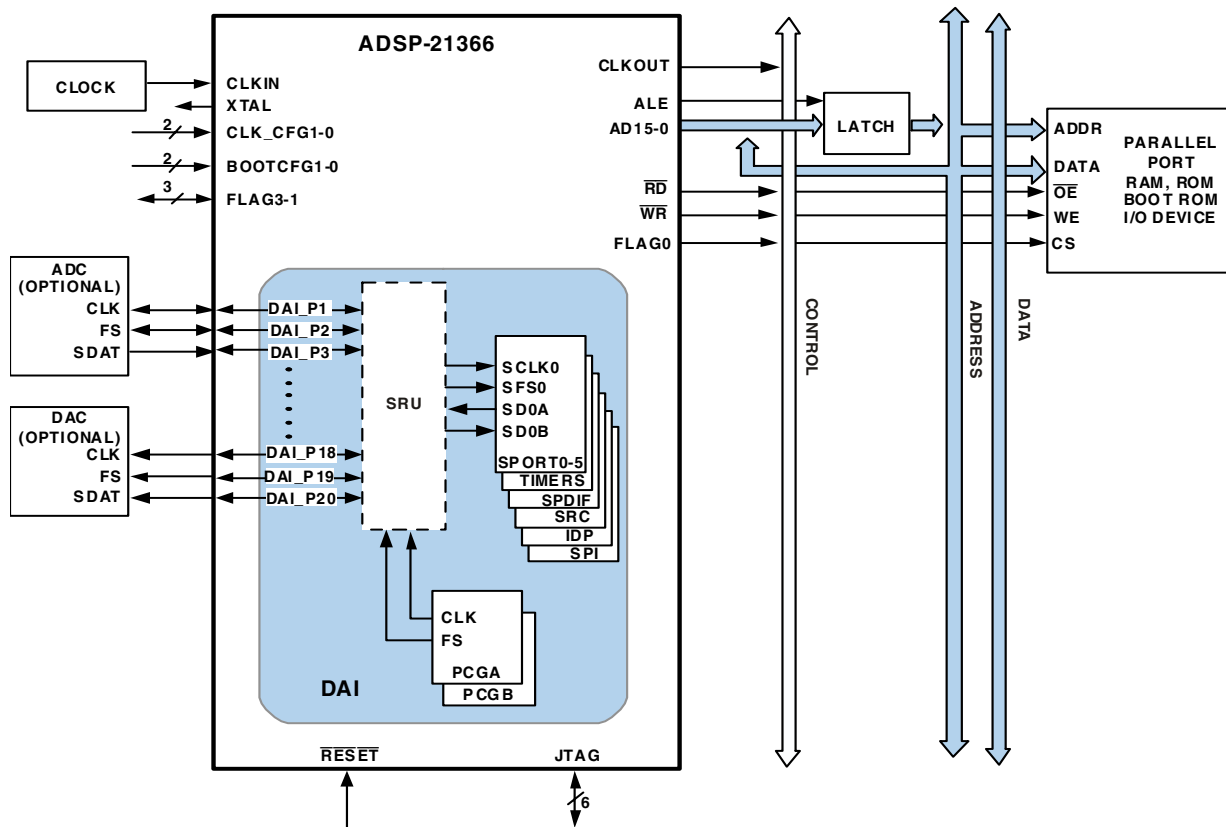

Figure 2. ADSP-21366 System Sample Configuration

### Independent, Parallel Computation Units

Within each processing element is a set of computational units. The computational units consist of an arithmetic/logic unit (ALU), multiplier, and shifter. These units perform all operations in a single cycle. The three units within each processing element are arranged in parallel, maximizing computational throughput. Single multifunction instructions execute parallel ALU and multiplier operations. In SIMD mode, the parallel ALU and multiplier operations occur in both processing elements. These computation units support IEEE 32-bit single-precision floating-point, 40-bit extended-precision floating-point, and 32-bit fixed-point data formats.

### Data Register File

A general-purpose data register file is contained in each processing element. The register files transfer data between the computation units and the data buses, and store intermediate results. These 10-port, 32-register (16 primary, 16 secondary) register files, combined with the ADSP-21366x enhanced Harvard architecture, allow unconstrained data flow between computation units and internal memory. The registers in PEX are referred to as R0–R15 and in PEY as S0–S15.

### Single-Cycle Fetch of Instruction and Four Operands

The ADSP-21366 features an enhanced Harvard architecture in which the data memory (DM) bus transfers data and the program memory (PM) bus transfers both instructions and data (see Figure 1 on Page 1). With the processor's separate program and data memory buses and on-chip instruction cache, the processor can simultaneously fetch four operands (two over each data bus) and one instruction (from the cache), all in a single cycle.

### Instruction Cache

The ADSP-21366 includes an on-chip instruction cache that enables three-bus operation for fetching an instruction and four data values. The cache is selective—only the instructions whose fetches conflict with PM bus data accesses are cached. This cache allows full-speed execution of core, looped operations such as digital filter multiply-accumulates, and FFT butterfly processing.

### Data Address Generators With Zero-Overhead Hardware Circular Buffer Support

The ADSP-21366's two data address generators (DAGs) are used for indirect addressing and implementing circular data buffers in hardware. Circular buffers allow efficient programming of delay lines and other data structures required in digital

# ADSP-21366

signal processing, and are commonly used in digital filters and Fourier transforms. The two DAGs contain sufficient registers to allow the creation of up to 32 circular buffers (16 primary register sets, 16 secondary). The DAGs automatically handle address pointer wraparound, reduce overhead, increase performance, and simplify implementation. Circular buffers can start and end at any memory location.

## Flexible Instruction Set

The 48-bit instruction word accommodates a variety of parallel operations, for concise programming. For example, the ADSP-21366 can conditionally execute a multiply, an add, and a subtract in both processing elements while branching and fetching up to four 32-bit values from memory—all in a single instruction.

## ADSP-21366 MEMORY AND I/O INTERFACE FEATURES

The ADSP-21366 adds the following architectural features to the SIMD SHARC family core.

## On-Chip Memory

The ADSP-21366 contains three megabits of internal SRAM and four megabits of internal ROM. Each block can be configured for different combinations of code and data storage (see Table 2). Each memory block supports single-cycle, independent accesses by the core processor and I/O processor. The processor's memory architecture, in combination with its separate on-chip buses, allows two data transfers from the core and one from the I/O processor, in a single cycle.

The ADSP-21366's SRAM can be configured as a maximum of 96K words of 32-bit data, 192K words of 16-bit data, 64K words of 48-bit instructions (or 40-bit data), or combinations of different word sizes up to three megabits. All of the memory can be accessed as 16-bit, 32-bit, 48-bit, or 64-bit words. A 16-bit floating-point storage format is supported that effectively doubles the amount of data that may be stored on-chip. Conversion between the 32-bit floating-point and 16-bit floating-point formats is performed in a single instruction. While each memory block can store combinations of code and data, accesses are most efficient when one block stores data using the DM bus for transfers, and the other block stores instructions and data using the PM bus for transfers.

Table 2. ADSP-21366 Internal Memory Space

IOP Registers 0x0000 0000–0003 FFFF			
Long Word (64 bits)	Extended Precision Normal or Instruction Word (48 bits)	Normal Word (32 bits)	Short Word (16 bits)
BLOCK 0 ROM 0x0004 0000–0x0004 7FFF	BLOCK 0 ROM 0x0008 0000–0x0008 AAA9	BLOCK 0 ROM 0x0008 0000–0x0008 FFFF	BLOCK 0 ROM 0x0010 0000–0x0011 FFFF
Reserved 0x0004 8000–0x0004 BFFF		Reserved 0x0009 0000–0x0009 7FFF	Reserved 0x0012 0000–0x0012 FFFF
BLOCK 0 RAM 0x0004 C000–0x0004 FFFF	BLOCK 0 RAM 0x0009 0000–0x0009 5554	BLOCK 0 RAM 0x0009 8000–0x0009 FFFF	BLOCK 0 RAM 0x0013 0000–0x0013 FFFF
BLOCK 1 ROM 0x0005 0000–0x0005 7FFF	BLOCK 1 ROM 0x000A 0000–0x000A AAA9	BLOCK 1 ROM 0x000A 0000–0x000A FFFF	BLOCK 1 ROM 0x0014 0000–0x0015 FFFF
Reserved 0x0005 8000–0x0005 BFFF		Reserved 0x000B 0000–0x000B 7FFF	Reserved 0x0016 0000–0x0016 FFFF
BLOCK 1 RAM 0x0005 C000–0x0005 FFFF	BLOCK 1 RAM 0x000B 0000–0x000B 5554	BLOCK 1 RAM 0x000B 8000–0x000B FFFF	BLOCK 1 RAM 0x0017 0000–0x0017 FFFF
BLOCK 2 RAM 0x0006 0000–0x0006 1FFF	BLOCK 2 RAM 0x000C 0000–0x000C 2AA9	BLOCK 2 RAM 0x000C 0000–0x000C 3FFF	BLOCK 2 RAM 0x0018 0000–0x0018 7FFF
Reserved 0x0006 2000–0x0006 FFFF		Reserved 0x000C 4000–0x000D FFFF	Reserved 0x0018 8000–0x001B FFFF
BLOCK 3 RAM 0x0007 0000–0x0007 1FFF	BLOCK 3 RAM 0x000E 0000–0x000E 2AA9	BLOCK 3 RAM 0x000E 0000–0x000E 3FFF	BLOCK 3 RAM 0x001C 0000–0x001C 7FFF
Reserved 0x0007 2000–0x0007 FFFF		Reserved 0x000E 4000–0x000F FFFF	Reserved 0x001C 8000–0x001F FFFF
			Reserved 0x0020 0000–0xFFFF FFFF



Using the DM bus and PM buses, with one bus dedicated to each memory block, assures single-cycle execution with two data transfers. In this case, the instruction must be available in the cache.

## DMA Controller

The ADSP-21366's on-chip DMA controllers allow data transfers without processor intervention. The DMA controller operates independently and invisibly to the processor core, allowing DMA operations to occur while the core is simultaneously executing its program instructions. DMA transfers can occur between the ADSP-21366's internal memory and its serial ports, the SPI-compatible (serial peripheral interface) ports, the IDP (input data port), the parallel data acquisition port (PDAP) or the parallel port. Twenty-five channels of DMA are available on the processors—two for the SPI interface, 12 via the serial ports, eight via the input data port, two for memory-to-memory data transfer, and one via the processor's parallel port. Programs can be downloaded to the processors using DMA transfers. Other DMA features include interrupt generation upon completion of DMA transfers, and DMA chaining for automatic linked DMA transfers.

## Digital Audio Interface (DAI)

The digital audio interface (DAI) provides the ability to connect various peripherals to any of the DSP's DAI pins (DAI\_P20-1).

Programs make these connections using the signal routing unit (SRU, shown in Figure 3).

The SRU is a matrix routing unit (or group of multiplexers) that enables the peripherals provided by the DAI to be interconnected under software control. This allows easy use of the DAI-associated peripherals for a much wider variety of applications by using a larger set of algorithms than is possible with nonconfigurable signal paths.

The DAI also includes six serial ports, an S/PDIF receiver/transmitter, a precision clock generator (PCG), eight channels of asynchronous sample rate converters, an input data port (IDP), an SPI port, six flag outputs and six flag inputs, and three timers. The IDP provides an additional input path to the ADSP-21366 core, configurable as either eight channels of I<sup>2</sup>S serial data or as seven channels plus a single 20-bit wide synchronous parallel data acquisition port. Each data channel has its own DMA channel that is independent from the processor's serial ports.

For complete information on using the DAI, see the *ADSP-2136x SHARC Processor Hardware Reference for the ADSP-21362/3/4/5/6 Processors*.

## Serial Ports

The ADSP-21366 features six synchronous serial ports that provide an inexpensive interface to a wide variety of digital and mixed-signal peripheral devices such as Analog Devices' AD183x family of audio codecs, ADCs, and DACs. The serial ports are made up of two data lines, a clock, and a frame sync. The data lines can be programmed to either transmit or receive and each data line has a dedicated DMA channel.

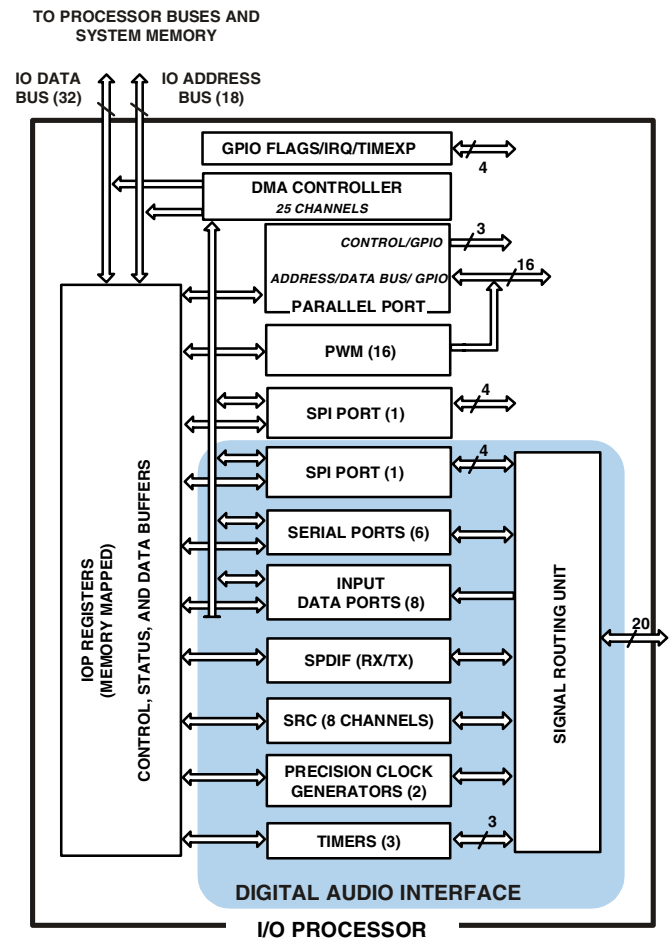

Figure 3. ADSP-21366 I/O Processor and Peripherals Block Diagram

Serial ports are enabled via 12 programmable and simultaneous receive or transmit pins that support up to 24 transmit or 24 receive channels of audio data when all six SPORTS are enabled, or six full duplex TDM streams of 128 channels per frame.

The serial ports operate at a maximum data rate of 50M bits/s. Serial port data can be automatically transferred to and from on-chip memory via dedicated DMA channels. Each of the serial ports can work in conjunction with another serial port to provide TDM support. One SPORT provides two transmit signals while the other SPORT provides the two receive signals. The frame sync and clock are shared.

Serial ports operate in four modes:

- Standard DSP serial mode
- Multichannel (TDM) mode
- I<sup>2</sup>S mode
- Left-justified sample pair mode

# ADSP-21366

Left-justified sample pair mode is a mode where in each frame sync cycle two samples of data are transmitted/received—one sample on the high segment of the frame sync, the other on the low segment of the frame sync. Programs have control over various attributes of this mode.

Each of the serial ports supports the left-justified sample pair and I<sup>2</sup>S protocols (I<sup>2</sup>S is an industry-standard interface commonly used by audio codecs, ADCs and DACs such as the Analog Devices AD183x family), with two data pins, allowing four left-justified sample pair or I<sup>2</sup>S channels (using two stereo devices) per serial port, with a maximum of up to 24 I<sup>2</sup>S channels. The serial ports permit little-endian or big-endian transmission formats and word lengths selectable from 3 bits to 32 bits. For the left-justified sample pair and I<sup>2</sup>S modes, data-word lengths are selectable between 8 bits and 32 bits. Serial ports offer selectable synchronization and transmit modes as well as optional  $\mu$ -law or A-law companding selection on a per channel basis. Serial port clocks and frame syncs can be internally or externally generated.

## Parallel Port

The parallel port provides interfaces to SRAM and peripheral devices. The multiplexed address and data pins (AD15–0) can access 8-bit devices with up to 24 bits of address, or 16-bit devices with up to 16 bits of address. In either mode, 8- or 16-bit, the maximum data transfer rate is 55M bytes/sec.

DMA transfers are used to move data to and from internal memory. Access to the core is also facilitated through the parallel port register read/write functions. The  $\overline{RD}$ ,  $\overline{WR}$ , and ALE (address latch enable) pins are the control pins for the parallel port.

## Serial Peripheral (Compatible) Interface

The processors contain two serial peripheral interface ports (SPIs). The SPI is an industry-standard synchronous serial link, enabling the ADSP-21366 SPI-compatible port to communicate with other SPI-compatible devices. The SPI consists of two data pins, one device select pin, and one clock pin. It is a full-duplex synchronous serial interface, supporting both master and slave modes. The SPI port can operate in a multimaster environment by interfacing with up to four other SPI-compatible devices, either acting as a master or slave device. The ADSP-21366 SPI-compatible peripheral implementation also features programmable baud rate and clock phase and polarities. The SPI-compatible port uses open drain drivers to support a multimaster configuration and to avoid data contention.

## S/PDIF-Compatible Digital Audio Receiver/Transmitter and Synchronous/Asynchronous Sample Rate Converter

The S/PDIF transmitter has no separate DMA channels. It receives audio data in serial format and converts it into a biphasic encoded signal. The serial data input to the transmitter can be formatted as left-justified, I<sup>2</sup>S, or right-justified with word widths of 16, 18, 20, or 24 bits.

The serial data, clock, and frame sync inputs to the S/PDIF transmitter are routed through the signal routing unit (SRU). They can come from a variety of sources such as the SPORTs,

external pins, the precision clock generators (PCGs), or the sample rate converters (SRC) and are controlled by the SRU control registers.

The sample rate converter (SRC) contains four SRC blocks and is the same core as that used in the AD1896 192 kHz stereo asynchronous sample rate converter and provides up to 128 dB SNR. The SRC block is used to perform synchronous or asynchronous sample rate conversion across independent stereo channels, without using internal processor resources. The four SRC blocks can also be configured to operate together to convert multichannel audio data without phase mismatches. Finally, the SRC is used to clean up audio data from jittery clock sources such as the S/PDIF receiver.

## Pulse-Width Modulation

The PWM module is a flexible, programmable, PWM waveform generator that can be programmed to generate the required switching patterns for various applications related to motor and engine control or audio power control. The PWM generator can generate either center-aligned or edge-aligned PWM waveforms. In addition, it can generate complementary signals on two outputs in paired mode or independent signals in non-paired mode (applicable to a single group of four PWM waveforms).

The entire PWM module has four groups of four PWM outputs each. Therefore, this module generates 16 PWM outputs in total. Each PWM group produces two pairs of PWM signals on the four PWM outputs.

The PWM generator is capable of operating in two distinct modes while generating center-aligned PWM waveforms: single update mode or double update mode. In single update mode the duty cycle values are programmable only once per PWM period. This results in PWM patterns that are symmetrical about the midpoint of the PWM period. In double update mode, a second updating of the PWM registers is implemented at the midpoint of the PWM period. In this mode, it is possible to produce asymmetrical PWM patterns that produce lower harmonic distortion in three-phase PWM inverters.

## Timers

The ADSP-21366 has a total of four timers: a core timer that can generate periodic software interrupts and three general-purpose timers that can generate periodic interrupts and be independently set to operate in one of three modes:

- Pulse waveform generation mode
- Pulse width count/capture mode
- External event watchdog mode

The core timer can be configured to use FLAG3 as a timer expired signal, and each general-purpose timer has one bidirectional pin and four registers that implement its mode of operation: a 6-bit configuration register, a 32-bit count register, a 32-bit period register, and a 32-bit pulse width register. A single control and status register enables or disables all three general-purpose timers independently.



## ROM-Based Security

The ADSP-21366 has a ROM security feature that provides hardware support for securing user software code by preventing unauthorized reading from the internal code when enabled. When using this feature, the processor does not boot-load any external code, executing exclusively from internal SRAM/ROM. Additionally, the processor is not freely accessible via the JTAG port. Instead, a unique 64-bit key, which must be scanned in through the JTAG or test access port will be assigned to each customer. The device will ignore a wrong key. Emulation features and external boot modes are only available after the correct key is scanned.

## Program Booting

The internal memory of the ADSP-21366 boots at system power-up from an 8-bit EPROM via the parallel port, an SPI master, an SPI slave, or an internal boot. Booting is determined by the boot configuration (BOOTCFG1–0) pins (see [Table 6 on Page 15](#)). Selection of the boot source is controlled via the SPI as either a master or slave device, or it can immediately begin executing from ROM.

## Phase-Locked Loop

The processors use an on-chip phase-locked loop (PLL) to generate the internal clock for the core. On power up, the CLKCFG1–0 pins are used to select ratios of 32:1, 16:1, and 6:1 (see [Table 7 on Page 15](#)). After booting, numerous other ratios can be selected via software control.

The ratios are made up of software configurable numerator values from 1 to 64 and software configurable divisor values of 1, 2, 4, and 8.

## Power Supplies

The ADSP-21366 has a separate power supply connection for the internal ( $V_{DDINT}$ ), external ( $V_{DDEXT}$ ), and analog ( $A_{VDD}/A_{VSS}$ ) power supplies. The internal and analog supplies must meet the 1.2 V requirement for K and B grade models, and the 1.0 V requirement for W grade models. The external supply must meet the 3.3 V requirement. All external supply pins must be connected to the same power supply.

Note that the analog supply pin ( $A_{VDD}$ ) powers the processor's internal clock generator PLL. To produce a stable clock, it is recommended that PCB designs use an external filter circuit for the  $A_{VDD}$  pin. Place the filter components as close as possible to the  $A_{VDD}/A_{VSS}$  pins. For an example circuit, see [Figure 4](#). (A recommended ferrite chip is the muRata BLM18AG102SN1D). To reduce noise coupling, the PCB should use a parallel pair of power and ground planes for  $V_{DDINT}$  and GND. Use wide traces to connect the bypass capacitors to the analog power ( $A_{VDD}$ ) and ground ( $A_{VSS}$ ) pins. Note that the  $A_{VDD}$  and  $A_{VSS}$  pins specified in [Figure 4](#) are inputs to the processor and not the analog ground plane on the board—the  $A_{VSS}$  pin should connect directly to digital ground (GND) at the chip.

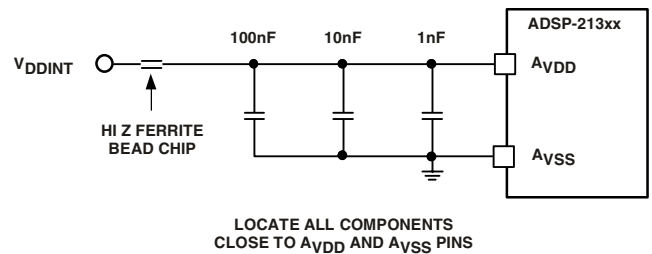

Figure 4. Analog Power ( $A_{VDD}$ ) Filter Circuit

## Target Board JTAG Emulator Connector

Analog Devices DSP Tools product line of JTAG emulators uses the IEEE 1149.1 JTAG test access port of the processor to monitor and control the target board processor during emulation. Analog Devices' DSP Tools product line of JTAG emulators provides emulation at full processor speed, allowing inspection and modification of memory, registers, and processor stacks. The processor's JTAG interface ensures that the emulator will not affect target system loading or timing.

For complete information on Analog Devices' SHARC DSP Tools product line of JTAG emulator operation, see the appropriate "Emulator Hardware User's Guide."

## DEVELOPMENT TOOLS

The ADSP-21366 is supported with a complete set of CROSS-CORE<sup>®</sup> software and hardware development tools, including Analog Devices emulators and VisualDSP++<sup>®</sup> development environment. The same emulator hardware that supports other SHARC processors also fully emulates the ADSP-21366.

The VisualDSP++ project management environment lets programmers develop and debug an application. This environment includes an easy to use assembler (which is based on an algebraic syntax), an archiver (librarian/library builder), a linker, a loader, a cycle-accurate instruction-level simulator, a C/C++ compiler, and a C/C++ runtime library that includes DSP and mathematical functions. A key point for these tools is C/C++ code efficiency. The compiler has been developed for efficient translation of C/C++ code to DSP assembly. The SHARC has architectural features that improve the efficiency of compiled C/C++ code.

The VisualDSP++ debugger has a number of important features. Data visualization is enhanced by a plotting package that offers a significant level of flexibility. This graphical representation of user data enables the programmer to quickly determine the performance of an algorithm. As algorithms grow in complexity, this capability can have increasing significance on the designer's development schedule, increasing productivity. Statistical profiling enables the programmer to nonintrusively poll the processor as it is running the program. This feature, unique to VisualDSP++, enables the software developer to passively gather important code execution metrics without interrupting the real-time characteristics of the program. Essentially, the developer can identify bottlenecks in software quickly and effi-

ciently. By using the profiler, the programmer can focus on those areas in the program that impact performance and take corrective action.

Debugging both C/C++ and assembly programs with the VisualDSP++ debugger, programmers can:

- View mixed C/C++ and assembly code (interleaved source and object information)
- Insert breakpoints
- Set conditional breakpoints on registers, memory, and stacks
- Trace instruction execution
- Perform linear or statistical profiling of program execution
- Fill, dump, and graphically plot the contents of memory
- Perform source level debugging
- Create custom debugger windows

The VisualDSP++ IDDE lets programmers define and manage DSP software development. Its dialog boxes and property pages let programmers configure and manage all of the SHARC development tools, including the color syntax highlighting in the VisualDSP++ editor. This capability permits programmers to:

- Control how the development tools process inputs and generate outputs
- Maintain a one-to-one correspondence with the tool's command line switches

The VisualDSP++ Kernel (VDK) incorporates scheduling and resource management tailored specifically to address the memory and timing constraints of DSP programming. These capabilities enable engineers to develop code more effectively, eliminating the need to start from the very beginning, when developing new application code. The VDK features include threads, critical and unscheduled regions, semaphores, events, and device flags. The VDK also supports priority-based, preemptive, cooperative, and time-sliced scheduling approaches. In addition, the VDK was designed to be scalable. If the application does not use a specific feature, the support code for that feature is excluded from the target system.

Because the VDK is a library, a developer can decide whether to use it or not. The VDK is integrated into the VisualDSP++ development environment, but can also be used via standard command line tools. When the VDK is used, the development environment assists the developer with many error-prone tasks and assists in managing system resources, automating the generation of various VDK-based objects, and visualizing the system state, when debugging an application that uses the VDK.

VisualDSP++ component software engineering (VCSE) is Analog Devices' technology for creating, using, and reusing software components (independent modules of substantial functionality) to quickly and reliably assemble software applications. It allows downloading components from the Web, dropping them into the application, and publishing component archives from within VisualDSP++. VCSE supports component implementation in C/C++ or assembly language.

Use the expert linker to visually manipulate the placement of code and data on the embedded system. View memory utilization in a color-coded graphical form, easily move code and data to different areas of the processor or external memory with a drag of the mouse and examine runtime stack and heap usage. The expert linker is fully compatible with the existing linker definition file (LDF), allowing the developer to move between the graphical and textual environments.

In addition to the software and hardware development tools available from Analog Devices, third parties provide a wide range of tools supporting the SHARC processor family. Hardware tools include SHARC processor PC plug-in cards. Third party software tools include DSP libraries, real-time operating systems, and block diagram design tools.

### **Designing an Emulator-Compatible DSP Board (Target)**

The Analog Devices family of emulators are tools that every DSP developer needs to test and debug hardware and software systems. Analog Devices has supplied an IEEE 1149.1 JTAG test access port (TAP) on each JTAG processor. Nonintrusive in-circuit emulation is assured by the use of the processor's JTAG interface—the emulator does not affect target system loading or timing. The emulator uses the TAP to access the internal features of the processor, allowing the developer to load code, set breakpoints, observe variables, observe memory, and examine registers. The processor must be halted to send data and commands, but once an operation has been completed by the emulator, the DSP system is set running at full speed with no impact on system timing.

To use these emulators, the target board must include a header that connects the DSP's JTAG port to the emulator.

For details on target board design issues including mechanical layout, single processor connections, multiprocessor scan chains, signal buffering, signal termination, and emulator pod logic, see the *EE-68: Analog Devices JTAG Emulation Technical Reference* on the Analog Devices website ([www.analog.com](http://www.analog.com))—use site search on “EE-68.” This document is updated regularly to keep pace with improvements to emulator support.

### **Evaluation Kit**

Analog Devices offers a range of EZ-KIT Lite evaluation platforms to use as a cost-effective method to learn more about developing or prototyping applications with Analog Devices processors, platforms, and software tools. Each EZ-KIT Lite includes an evaluation board along with an evaluation suite of the VisualDSP++ development and debugging environment with the C/C++ compiler, assembler, and linker. Also included are sample application programs, power supply, and a USB cable. All evaluation versions of the software tools are limited for use only with the EZ-KIT Lite product.

The USB controller on the EZ-KIT Lite board connects the board to the USB port of the user's PC, enabling the VisualDSP++ evaluation suite to emulate the on-board processor in-circuit. This permits the customer to download, execute, and debug programs for the EZ-KIT Lite system. It also allows

in-circuit programming of the on-board flash device to store user-specific boot code, enabling the board to run as a stand-alone unit without being connected to the PC.

With a full version of VisualDSP++ installed (sold separately), engineers can develop software for the EZ-KIT Lite or any custom defined system. Connecting one of Analog Devices' JTAG emulators to the EZ-KIT Lite board enables high speed, non-intrusive emulation.

## ADDITIONAL INFORMATION

This data sheet provides a general overview of the ADSP-21366 architecture and functionality. For detailed information on the ADSP-2136x family core architecture and instruction set, refer to the *ADSP-2136x SHARC Processor Hardware Reference for the ADSP-21362/3/4/5/6 Processors* and the *ADSP-2136x SHARC Processor Programming Reference*.

## PIN FUNCTION DESCRIPTIONS

The ADSP-21366 pin definitions are listed below. Inputs identified as synchronous (S) must meet timing requirements with respect to CLKIN (or with respect to TCK for TMS and TDI). Inputs identified as asynchronous (A) can be asserted asynchronously to CLKIN (or to TCK for  $\overline{\text{TRST}}$ ). Tie or pull unused inputs to  $V_{\text{DDEXT}}$  or GND, except for the following:

- DAI\_Px, SPICLK, MISO, MOSI,  $\overline{\text{EMU}}$ , TMS,  $\overline{\text{TRST}}$ , TDI, and AD15–0 (NOTE: These pins have pull-up resistors.)

The following symbols appear in the Type column of Table 3:

A = asynchronous, G = ground, I = input, O = output, P = power supply, S = synchronous, (A/D) = active drive, (O/D) = open drain, and T = three-state, (pd) = pull-down resistor, (pu) = pull-up resistor.

**Table 3. Pin Descriptions**

Pin	Type	State During and After Reset	Function
AD15–0	I/O/T (pu)	Three-state with pull-up enabled	<b>Parallel Port Address/Data.</b> The ADSP-21366 parallel port and its corresponding DMA unit output addresses and data for peripherals on these multiplexed pins. The multiplex state is determined by the ALE pin. The parallel port can operate in either 8-bit or 16-bit mode. Each AD pin has a 22.5 k $\Omega$ internal pull-up resistor. See <a href="#">Address/Data Modes on Page 15</a> for details of the AD pin operation. For 8-bit mode: ALE is automatically asserted whenever a change occurs in the upper 16 external address bits, A23–8; ALE is used in conjunction with an external latch to retain the values of the A23–8. For detailed information on I/O operations and pin multiplexing, see the <i>ADSP-2136x SHARC Processor Hardware Reference for the ADSP-21362/3/4/5/6 Processors</i> .
$\overline{\text{RD}}$	O (pu)	Three-state, driven high <sup>1</sup>	<b>Parallel Port Read Enable.</b> $\overline{\text{RD}}$ is asserted low whenever the processor reads 8-bit or 16-bit data from an external memory device. When AD15–0 are flags, this pin remains deasserted. $\overline{\text{RD}}$ has a 22.5 k $\Omega$ internal pull-up resistor.
$\overline{\text{WR}}$	O (pu)	Three-state, driven high <sup>1</sup>	<b>Parallel Port Write Enable.</b> $\overline{\text{WR}}$ is asserted low whenever the processor writes 8-bit or 16-bit data to an external memory device. When AD15–0 are flags, this pin remains deasserted. $\overline{\text{WR}}$ has a 22.5 k $\Omega$ internal pull-up resistor.
ALE	O (pd)	Three-state, driven low <sup>1</sup>	<b>Parallel Port Address Latch Enable.</b> ALE is asserted whenever the processor drives a new address on the parallel port address pins. On reset, ALE is active high. However, it can be reconfigured using software to be active low. When AD15–0 are flags, this pin remains deasserted. ALE has a 20 k $\Omega$ internal pull-down resistor.
FLAG3–0	I/O/A	Three-state	<b>Flag Pins.</b> Each flag pin is configured via control bits as either an input or output. As an input, it can be tested as a condition. As an output, it can be used to signal external peripherals. These pins can be used as an SPI interface slave select output during SPI mastering. These pins are also multiplexed with the $\overline{\text{IRQx}}$ and the TIMEXP signals. For detailed information on I/O operations and pin multiplexing, see the <i>ADSP-2136x SHARC Processor Hardware Reference for the ADSP-21362/3/4/5/6 Processors</i>
DAI_P20–1	I/O/T (pu)	Three-state with programmable pull-up	<b>Digital Audio Interface Pins.</b> These pins provide the physical interface to the SRU. The SRU configuration registers define the combination of on-chip peripheral inputs or outputs connected to the pin and to the pin's output enable. The configuration registers of these peripherals then determines the exact behavior of the pin. Any input or output signal present in the SRU may be routed to any of these pins. The SRU provides the connection from the serial ports, input data port, precision clock generators and timers, sample rate converters and SPI to the DAI_P20–1 pins. These pins have internal 22.5 k $\Omega$ pull-up resistors which are enabled on reset. These pull-ups can be disabled in the DAI_PIN_PULLUP register.

Table 3. Pin Descriptions (Continued)

Pin	Type	State During and After Reset	Function
SPICLK	I/O (pu)	Three-state with pull-up enabled	<b>Serial Peripheral Interface Clock Signal.</b> Driven by the master, this signal controls the rate at which data is transferred. The master may transmit data at a variety of baud rates. SPICLK cycles once for each bit transmitted. SPICLK is a gated clock that is active during data transfers, only for the length of the transferred word. Slave devices ignore the serial clock if the slave select input is driven inactive (HIGH). SPICLK is used to shift out and shift in the data driven on the MISO and MOSI lines. The data is always shifted out on one clock edge and sampled on the opposite edge of the clock. Clock polarity and clock phase relative to data are programmable into the SPICLK control register and define the transfer format. SPICLK has a 22.5 k $\Omega$ internal pull-up resistor.
$\overline{\text{SPID}}\text{S}$	I	Input only	<b>Serial Peripheral Interface Slave Device Select.</b> An active low signal used to select the processor as an SPI slave device. This input signal behaves like a chip select, and is provided by the master device for the slave devices. In multimaster mode the processor's $\overline{\text{SPID}}\text{S}$ signal can be driven by a slave device to signal to the processor (as SPI master) that an error has occurred, as some other device is also trying to be the master device. If asserted low when the device is in master mode, it is considered a multimaster error. For a single-master, multiple-slave configuration where flag pins are used, this pin must be tied or pulled high to V <sub>DDEXT</sub> on the master device. For processor to processor SPI interaction, any of the master processor's flag pins can be used to drive the $\overline{\text{SPID}}\text{S}$ signal on the SPI slave device.
MOSI	I/O (O/D) (pu)	Three-state with pull-up enabled	<b>SPI Master Out Slave In.</b> If the ADSP-21366 is configured as a master, the MOSI pin becomes a data transmit (output) pin, transmitting output data. If the processor is configured as a slave, the MOSI pin becomes a data receive (input) pin, receiving input data. In a SPI interconnection, the data is shifted out from the MOSI output pin of the master and shifted into the MOSI input(s) of the slave(s). MOSI has a 22.5 k $\Omega$ internal pull-up resistor.
MISO	I/O (O/D) (pu)	Three-state with pull-up enabled	<b>SPI Master In Slave Out.</b> If the ADSP-21366 is configured as a master, the MISO pin becomes a data receive (input) pin, receiving input data. If the processor is configured as a slave, the MISO pin becomes a data transmit (output) pin, transmitting output data. In an SPI interconnection, the data is shifted out from the MISO output pin of the slave and shifted into the MISO input pin of the master. MISO has a 22.5 k $\Omega$ internal pull-up resistor. MISO can be configured as O/D by setting the OPD bit in the SPICLK register. <b>Note:</b> Only one slave is allowed to transmit data at any given time. To enable broadcast transmission to multiple SPI-slaves, the processor's MISO pin may be disabled by setting (=1) Bit 5 (DMISO) of the SPICLK register.
BOOTCFG1-0	I	Input only	<b>Boot Configuration Select.</b> This pin is used to select the boot mode for the processor. The BOOTCFG pins must be valid before reset is asserted. See Table 6 for a description of the boot modes.
CLKIN	I	Input only	<b>Local Clock In.</b> Used in conjunction with XTAL. CLKIN is the ADSP-21366 clock input. It configures the ADSP-21366 to use either its internal clock generator or an external clock source. Connecting the necessary components to CLKIN and XTAL enables the internal clock generator. Connecting the external clock to CLKIN while leaving XTAL unconnected configures the processors to use the external clock source such as an external clock oscillator. The core is clocked either by the PLL output or this clock input depending on the CLKCFG1-0 pin settings. CLKIN may not be halted, changed, or operated below the specified frequency.
XTAL	O	Output only <sup>2</sup>	<b>Crystal Oscillator Terminal.</b> Used in conjunction with CLKIN to drive an external crystal.
CLKCFG1-0	I	Input only	<b>Core/CLKIN Ratio Control.</b> These pins set the start up clock frequency. See Table 7 for a description of the clock configuration modes. Note that the operating frequency can be changed by programming the PLL multiplier and divider in the PMCTL register at any time after the core comes out of reset.

# ADSP-21366

Table 3. Pin Descriptions (Continued)

Pin	Type	State During and After Reset	Function
RSTOUT/CLKOUT	O	Output only	<b>Local Clock Out/Reset Out.</b> Drives out the core reset signal to an external device. CLKOUT can also be configured as a reset out pin. The functionality can be switched between the PLL output clock and reset out by setting Bit 12 of the PMCTREG register. The default is reset out.
$\overline{\text{RESET}}$	I/A	Input only	<b>Processor Reset.</b> Resets the ADSP-21366 to a known state. Upon deassertion, there is a 4096 CLKIN cycle latency for the PLL to lock. After this time, the core begins program execution from the hardware reset vector address. The $\overline{\text{RESET}}$ input must be asserted (low) at power-up.
TCK	I	Input only <sup>3</sup>	<b>Test Clock (JTAG).</b> Provides a clock for JTAG boundary scan. TCK must be asserted (pulsed low) after power-up or held low for proper operation of the processors.
TMS	I/S (pu)	Three-state with pull-up enabled	<b>Test Mode Select (JTAG).</b> Used to control the test state machine. TMS has a 22.5 k $\Omega$ internal pull-up resistor.
TDI	I/S (pu)	Three-state with pull-up enabled	<b>Test Data Input (JTAG).</b> Provides serial data for the boundary scan logic. TDI has a 22.5 k $\Omega$ internal pull-up resistor.
TDO	O	Three-state <sup>4</sup>	<b>Test Data Output (JTAG).</b> Serial scan output of the boundary scan path.
$\overline{\text{TRST}}$	I/A (pu)	Three-state with pull-up enabled	<b>Test Reset (JTAG).</b> Resets the test state machine. $\overline{\text{TRST}}$ must be asserted (pulsed low) after power-up or held low for proper operation of the ADSP-21366. $\overline{\text{TRST}}$ has a 22.5 k $\Omega$ internal pull-up resistor.
$\overline{\text{EMU}}$	O (O/D) (pu)	Three-state with pull-up enabled	<b>Emulation Status.</b> Must be connected to the processor's JTAG emulators target board connector only. $\overline{\text{EMU}}$ has a 22.5 k $\Omega$ internal pull-up resistor.
V <sub>DDINT</sub>	P		<b>Core Power Supply.</b> Nominally +1.2 V dc for the K and B grade models, and 1.0 V dc for the W grade models, and supplies the processor's core (13 pins on the BGA package).
V <sub>DDEXT</sub>	P		<b>I/O Power Supply.</b> Nominally +3.3 V dc. (6 pins on the BGA package).
A <sub>VDD</sub>	P		<b>Analog Power Supply.</b> Nominally +1.2 V dc for the K and B grade models, and 1.0 V dc for the W grade models, and supplies the processor's internal PLL (clock generator). This pin has the same specifications as V <sub>DDINT</sub> , except that added filtering circuitry is required. <a href="#">For more information, see Power Supplies on Page 9.</a>
A <sub>VSS</sub>	G		<b>Analog Power Supply Return.</b>
GND	G		<b>Power Supply Return.</b> (54 pins on the BGA package).

<sup>1</sup> $\overline{\text{RD}}$ ,  $\overline{\text{WR}}$ , and ALE are three-stated (and not driven) only when RESET is active.

<sup>2</sup>Output only is a three-state driver with its output path always enabled.

<sup>3</sup>Input only is a three-state driver with both output path and pull-up disabled.

<sup>4</sup>Three-state is a three-state driver with pull-up disabled.



### ADDRESS DATA PINS AS FLAGS

To use these pins as flags (FLAGS15–0) set (=1) Bit 20 of the SYCTL register to disable the parallel port. Then set (=1) Bits 22 to 25 in the SYCTL register accordingly.

**Table 4. AD15–0 to Flag Pin Mapping**

AD Pin	Flag Pin	AD Pin	Flag Pin
AD0	FLAG8	AD8	FLAG0
AD1	FLAG9	AD9	FLAG1
AD2	FLAG10	AD10	FLAG2
AD3	FLAG11	AD11	FLAG3
AD4	FLAG12	AD12	FLAG4
AD5	FLAG13	AD13	FLAG5
AD6	FLAG14	AD14	FLAG6
AD7	FLAG15	AD15	FLAG7

### ADDRESS/DATA MODES

The following table shows the functionality of the AD pins for 8-bit and 16-bit transfers to the parallel port. For 8-bit data transfers, ALE latches address bits A23–A8 when asserted, followed by address bits A7–A0 and data bits D7–D0 when deasserted. For 16-bit data transfers, ALE latches address bits A15–A0 when asserted, followed by data bits D15–D0 when deasserted.

**Table 5. Address/Data Mode Selection**

PP Data Mode	ALE	AD7–0 Function	AD15–8 Function
8-bit	Asserted	A15–8	A23–16
8-bit	Deasserted	D7–0	A7–0
16-bit	Asserted	A7–0	A15–8
16-bit	Deasserted	D7–0	D15–8

### BOOT MODES

**Table 6. Boot Mode Selection**

BOOTCFG1–0	Booting Mode
00	SPI Slave Boot
01	SPI Master Boot
10	Parallel Port Boot via EPROM

### CORE INSTRUCTION RATE TO CLKIN RATIO MODES

For details on processor timing, see [Timing Specifications](#) and [Figure 5 on Page 18](#).

**Table 7. Core Instruction Rate/CLKIN Ratio Selection**

CLKCFG1–0	Core to CLKIN Ratio
00	6:1
01	32:1
10	16:1

# ADSP-21366

## ADSP-21366 SPECIFICATIONS

### RECOMMENDED OPERATING CONDITIONS

Table 8.

Parameter <sup>1</sup>		K Grade		B Grade		W Grade		Unit
		Min	Max	Min	Max	Min	Max	
V <sub>DDINT</sub>	Internal (Core) Supply Voltage	1.14	1.26	1.14	1.26	0.95	1.05	V
A <sub>VDD</sub>	Analog (PLL) Supply Voltage	1.14	1.26	1.14	1.26	0.95	1.05	V
V <sub>DDEXT</sub>	External (I/O) Supply Voltage	3.13	3.47	3.13	3.47	3.13	3.47	V
V <sub>IH</sub> <sup>2</sup>	High Level Input Voltage @ V <sub>DDEXT</sub> = max	2.0	V <sub>DDEXT</sub> + 0.5	2.0	V <sub>DDEXT</sub> + 0.5	2.0	V <sub>DDEXT</sub> + 0.5	V
V <sub>IL</sub> <sup>2</sup>	Low Level Input Voltage @ V <sub>DDEXT</sub> = min	-0.5	+0.8	-0.5	+0.8	-0.5	+0.8	V
V <sub>IH_CLKIN</sub> <sup>3</sup>	High Level Input Voltage @ V <sub>DDEXT</sub> = max	1.74	V <sub>DDEXT</sub> + 0.5	1.74	V <sub>DDEXT</sub> + 0.5	1.74	V <sub>DDEXT</sub> + 0.5	V
V <sub>IL_CLKIN</sub>	Low Level Input Voltage @ V <sub>DDEXT</sub> = min	-0.5	+1.19	-0.5	+1.19	-0.5	+1.19	V
T <sub>AMB</sub> <sup>4,5</sup>	Ambient Operating Temperature	0	+70	-40	+85	-40	+105	°C

<sup>1</sup> Specifications subject to change without notice.

<sup>2</sup> Applies to input and bidirectional pins: AD15-0, FLAG3-0, DAI\_Px, SPICLK, MOSI, MISO,  $\overline{\text{SPIDS}}$ , BOOTCFGx, CLKCFGx,  $\overline{\text{RESET}}$ , TCK, TMS, TDI,  $\overline{\text{TRST}}$ .

<sup>3</sup> Applies to input pin CLKIN.

<sup>4</sup> See [Thermal Characteristics on Page 46](#) for information on thermal specifications.

<sup>5</sup> See Engineer-to-Engineer Note (No. EE-277) for further information.

### ELECTRICAL CHARACTERISTICS

Table 9.

Parameter <sup>1</sup>	Test Conditions	Min	Max	Unit
V <sub>OH</sub> <sup>2</sup>	High Level Output Voltage	@ V <sub>DDEXT</sub> = min, I <sub>OH</sub> = -1.0 mA <sup>3</sup>	2.4	V
V <sub>OL</sub> <sup>2</sup>	Low Level Output Voltage	@ V <sub>DDEXT</sub> = min, I <sub>OL</sub> = 1.0 mA <sup>3</sup>		V
I <sub>IH</sub> <sup>4,5</sup>	High Level Input Current	@ V <sub>DDEXT</sub> = max, V <sub>IN</sub> = V <sub>DDEXT</sub> max	10	μA
I <sub>IL</sub> <sup>4</sup>	Low Level Input Current	@ V <sub>DDEXT</sub> = max, V <sub>IN</sub> = 0 V	10	μA
I <sub>ILPU</sub> <sup>5</sup>	Low Level Input Current Pull-Up	@ V <sub>DDEXT</sub> = max, V <sub>IN</sub> = 0 V	200	μA
I <sub>OZH</sub> <sup>6,7</sup>	Three-State Leakage Current	@ V <sub>DDEXT</sub> = max, V <sub>IN</sub> = V <sub>DDEXT</sub> max	10	μA
I <sub>OZL</sub> <sup>6</sup>	Three-State Leakage Current	@ V <sub>DDEXT</sub> = max, V <sub>IN</sub> = 0 V	10	μA
I <sub>OZLPU</sub> <sup>7</sup>	Three-State Leakage Current Pull-Up	@ V <sub>DDEXT</sub> = max, V <sub>IN</sub> = 0 V	200	μA
I <sub>DD-INTYP</sub> <sup>8,9</sup>	Supply Current (Internal)	t <sub>CLK</sub> = min, V <sub>DDINT</sub> = nom	800	mA
A <sub>IDD</sub> <sup>10</sup>	Supply Current (Analog)	A <sub>VDD</sub> = max	10	mA
C <sub>IN</sub> <sup>11,12</sup>	Input Capacitance	f <sub>IN</sub> = 1 MHz, T <sub>CASE</sub> = 25°C, V <sub>IN</sub> = 1.2V	4.7	pF

<sup>1</sup> Specifications subject to change without notice.

<sup>2</sup> Applies to output and bidirectional pins: AD15-0,  $\overline{\text{RD}}$ ,  $\overline{\text{WR}}$ , ALE, FLAG3-0, DAI\_Px, SPICLK, MOSI, MISO,  $\overline{\text{EMU}}$ , TDO, CLKOUT, XTAL.

<sup>3</sup> See [Output Drive Currents on Page 45](#) for typical drive current capabilities.

<sup>4</sup> Applies to input pins:  $\overline{\text{SPIDS}}$ , BOOTCFGx, CLKCFGx, TCK,  $\overline{\text{RESET}}$ , CLKIN.

<sup>5</sup> Applies to input pins with 22.5 kΩ internal pull-ups: TRST, TMS, TDI.

<sup>6</sup> Applies to three-statable pins: FLAG3-0.

<sup>7</sup> Applies to three-statable pins with 22.5 kΩ pull-ups: AD15-0, DAI\_Px, SPICLK,  $\overline{\text{EMU}}$ ,  $\overline{\text{MISO}}$ ,  $\overline{\text{MOSI}}$ .

<sup>8</sup> Typical internal current data reflects nominal operating conditions.

<sup>9</sup> See Engineer-to-Engineer Note (No. EE-277) for further information.

<sup>10</sup> Characterized, but not tested.

<sup>11</sup> Applies to all signal pins.

<sup>12</sup> Guaranteed, but not tested.

## MAXIMUM POWER DISSIPATION

See Engineer-to-Engineer Note (EE-277) for detailed thermal and power information regarding maximum power dissipation. For information on package thermal specifications, see [Thermal Characteristics on Page 46](#).

## ABSOLUTE MAXIMUM RATINGS

Parameter	Rating
Internal (Core) Supply Voltage ( $V_{DDINT}$ ) <sup>1</sup>	-0.3 V to +1.5 V
Analog (PLL) Supply Voltage ( $A_{VDD}$ ) <sup>1</sup>	-0.3 V to +1.5 V
External (I/O) Supply Voltage ( $V_{DDEXT}$ ) <sup>1</sup>	-0.3 V to +4.6 V
Input Voltage -0.5 V to $V_{DDEXT}$ <sup>1</sup>	+0.5 V
Output Voltage Swing -0.5 V to $V_{DDEXT}$ <sup>1</sup>	+0.5 V
Load Capacitance <sup>1</sup>	200 pF
Storage Temperature Range <sup>1</sup>	-65°C to +150°C
Junction Temperature under Bias <sup>1</sup>	125°C

<sup>1</sup>Stresses greater than those listed above may cause permanent damage to the device. These are stress ratings only; functional operation of the device at these or any other conditions greater than those indicated in the operational sections of this specification is not implied. Exposure to absolute maximum rating conditions for extended periods may affect device reliability.

## ESD SENSITIVITY

### CAUTION

ESD (electrostatic discharge) sensitive device. Electrostatic charges as high as 4000 V readily accumulate on the human body and test equipment and can discharge without detection. Although the ADSP-21366 features proprietary ESD protection circuitry, permanent damage may occur on devices subjected to high energy electrostatic discharges. Therefore, proper ESD precautions are recommended to avoid performance degradation or loss of functionality.



# ADSP-21366

## TIMING SPECIFICATIONS

The ADSP-21366's internal clock (a multiple of CLKIN) provides the clock signal for timing internal memory, processor core, serial ports, and parallel port (as required for read/write strobes in asynchronous access mode). During reset, program the ratio between the processor's internal clock frequency and external (CLKIN) clock frequency with the CLKCFG1-0 pins (see Table 7 on Page 15). To determine switching frequencies for the serial ports, divide down the internal clock, using the programmable divider control of each port (DIVx for the serial ports).

The ADSP-21366's internal clock switches at higher frequencies than the system input clock (CLKIN). To generate the internal clock, the processor uses an internal phase-locked loop (PLL). This PLL-based clocking minimizes the skew between the system clock (CLKIN) signal and the processor's internal clock (the clock source for the parallel port logic and I/O pads).

Note the definitions of various clock periods that are a function of CLKIN and the appropriate ratio control shown in Table 10.

**Table 10. ADSP-21366 CLKOUT and CCLK Clock Generation Operation**

Timing Requirements	Description	Calculation
CLKIN	Input Clock	$1/t_{CK}$
CCLK	Core Clock	$1/t_{CCLK}$

Figure 5 shows core to CLKIN ratios of 6:1, 16:1 and 32:1 with external oscillator or crystal. Note that more ratios are possible and can be set through software using the power management control register (PMCTL). For more information, see the *ADSP-2136x SHARC Processor Programming Reference*.

Use the exact timing information given. Do not attempt to derive parameters from the addition or subtraction of others. While addition or subtraction would yield meaningful results for an individual device, the values given in this data sheet reflect statistical variations and worst cases. Consequently, it is not meaningful to add parameters to derive longer times. See Figure 38 on Page 45 under Test Conditions for voltage reference levels.

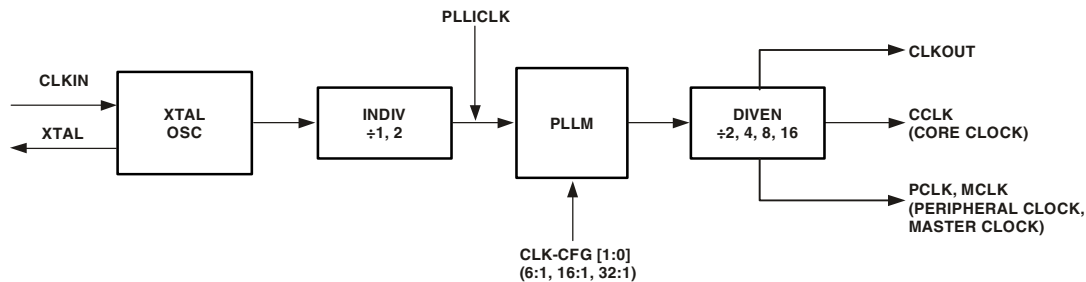

Figure 5. Core Clock and System Clock Relationship to CLKIN

**Table 11. Clock Periods**

Timing Requirements	Description <sup>1</sup>
$t_{CK}$	CLKIN Clock Period
$t_{CCLK}$	(Processor) Core Clock Period
$t_{PCLK}$	(Peripheral) Clock Period = $2 \times t_{CCLK}$
$t_{SCLK}$	Serial Port Clock Period = $(t_{PCLK}) \times SR$
$t_{SPICLK}$	SPI Clock Period = $(t_{PCLK}) \times SPIR$

<sup>1</sup> where:

SR = serial port-to-peripheral clock ratio (wide range, determined by SPORT CLKDIV)

SPIR = SPI-to-peripheral clock ratio (wide range, determined by SPIBAUD register)

DAL\_Px = serial port clock

SPICLK = SPI clock

*Switching Characteristics* specify how the processor changes its signals. Circuitry external to the processor must be designed for compatibility with these signal characteristics. Switching characteristics describe what the processor will do in a given circumstance. Use switching characteristics to ensure that any timing requirement of a device connected to the processor (such as memory) is satisfied.

*Timing Requirements* apply to signals that are controlled by circuitry external to the processor, such as the data input for a read operation. Timing requirements guarantee that the processor operates correctly with other devices.

**Power-Up Sequencing**

The timing requirements for processor startup are given in [Table 12](#).

**Table 12. Power Up Sequencing Timing Requirements (Processor Startup)**

Parameter		Min	Max	Unit
<i>Timing Requirements</i>				
$t_{RSTVDD}$	$\overline{RESET}$ Low Before $V_{DDINT}/V_{DDEXT}$ On	0		ns
$t_{VDDEVDD}$	$V_{DDINT}$ On Before $V_{DDEXT}$	-50	200	ms
$t_{CLKVDD}^1$	CLKIN Valid After $V_{DDINT}/V_{DDEXT}$ Valid	0	200	ms
$t_{CLKRST}$	CLKIN Valid Before $\overline{RESET}$ Deasserted	$10^2$		$\mu$ s
$t_{PLLST}$	PLL Control Setup Before $\overline{RESET}$ Deasserted	20		$\mu$ s
<i>Switching Characteristic</i>				
$t_{CORERST}$	Core Reset Deasserted After $\overline{RESET}$ Deasserted	$4096t_{CK} + 2 t_{CCLK}^{3,4}$		

<sup>1</sup> Valid  $V_{DDINT}/V_{DDEXT}$  assumes that the supplies are fully ramped to their 1.2 and 3.3 volt rails. Voltage ramp rates can vary from microseconds to hundreds of milliseconds depending on the design of the power supply subsystem.

<sup>2</sup> Assumes a stable CLKIN signal, after meeting worst-case start-up timing of crystal oscillators. Refer to your crystal oscillator manufacturer’s data sheet for start-up time. Assume a 25 ms maximum oscillator start-up time if using the XTAL pin and internal oscillator circuit in conjunction with an external crystal.

<sup>3</sup> Applies after the power-up sequence is complete. Subsequent resets require a minimum of 4 CLKIN cycles for  $\overline{RESET}$  to be held low in order to properly initialize and propagate default states at all I/O pins.

<sup>4</sup> The 4096 cycle count depends on  $t_{SRST}$  specification in [Table 14](#). If setup time is not met, 1 additional CLKIN cycle may be added to the core reset time, resulting in 4097 cycles maximum.

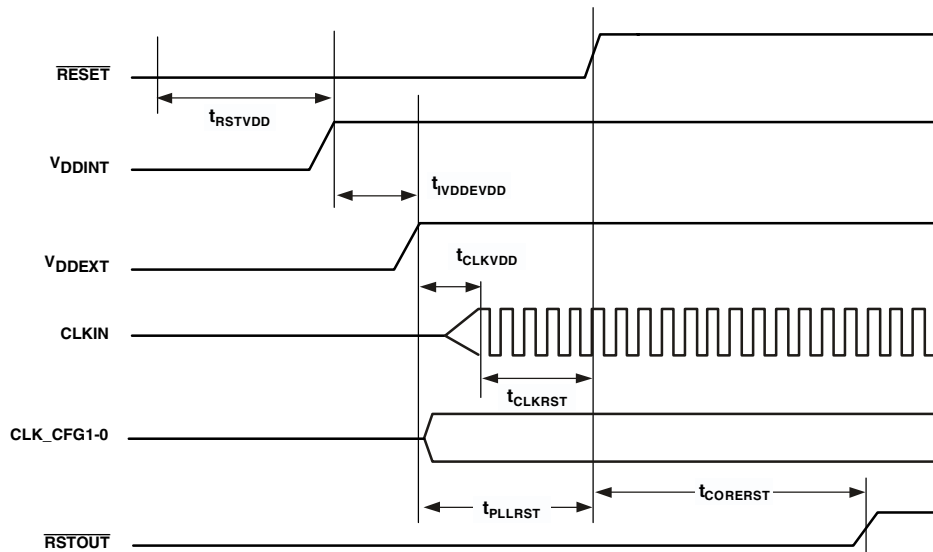

Figure 6. Power-Up Sequencing

# ADSP-21366

## Clock Input

Table 13. Clock Input

Parameter	333 MHz		Unit	
	Min	Max		
<i>Timing Requirements</i>				
$t_{CK}$	CLKIN Period	18 <sup>1</sup>	100	ns
$t_{CKL}$	CLKIN Width Low	7.5 <sup>1</sup>		ns
$t_{CKH}$	CLKIN Width High	7.5 <sup>1</sup>		ns
$t_{CKRF}$	CLKIN Rise/Fall (0.4 V–2.0 V)		3	ns
$t_{CCLK}$ <sup>2</sup>	CCLK Period	3.0 <sup>1</sup>	10	ns
$t_{CKJ}$ <sup>3,4</sup>	CLKIN Jitter Tolerance	-250	+250	ps

<sup>1</sup> Applies only for CLKCFG1-0 = 00 and default values for PLL control bits in PMCTL.

<sup>2</sup> Any changes to PLL control bits in the PMCTL register must meet core clock timing specification  $t_{CCLK}$ .

<sup>3</sup> Actual input jitter should be combined with ac specifications for accurate timing analysis.

<sup>4</sup> Jitter specification is maximum peak-to-peak time interval error (TIE) jitter.

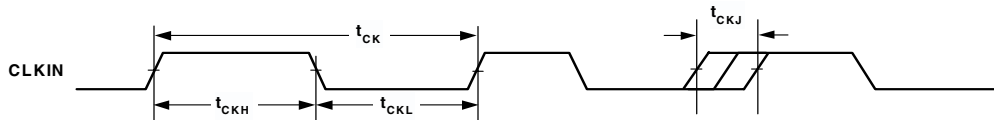
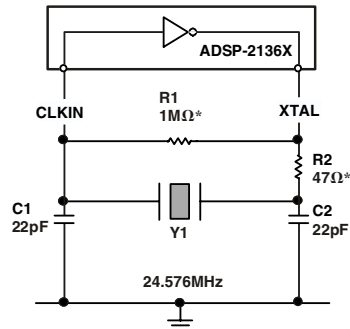

Figure 7. Clock Input

## Clock Signals

The ADSP-21366 can use an external clock or a crystal. See the CLKIN pin description in Table 3 on Page 12. The user application program can configure the ADSP-21366 to use its internal clock generator by connecting the necessary components to the CLKIN and XTAL pins. Figure 8 shows the component connections used for a fundamental frequency crystal operating in parallel mode.

Note that the clock rate is achieved using a 16.67 MHz crystal and a PLL multiplier ratio 16:1 (CCLK:CLKIN achieves a clock speed of 266.72 MHz). To achieve the full core clock rate, programs need to configure the multiplier bits in the PMCTL register.



R2 SHOULD BE CHOSEN TO LIMIT CRYSTAL DRIVE POWER. REFER TO CRYSTAL MANUFACTURER'S SPECIFICATIONS

\*TYPICAL VALUES

Figure 8. 333 MHz Operation (Fundamental Mode Crystal)



**Reset**

**Table 14. Reset**

Parameter	Min	Max	Unit
<i>Timing Requirements</i>			
$t_{WRST}^1$ $\overline{RESET}$ Pulse Width Low	$4t_{CK}$		ns
$t_{SRST}$ $\overline{RESET}$ Setup Before CLKIN Low	8		ns

<sup>1</sup> Applies after the power-up sequence is complete. At power-up, the processor's internal phase-locked loop requires no more than 100  $\mu$ s while  $\overline{RESET}$  is low, assuming stable VDD and CLKIN (not including start-up time of external clock oscillator).

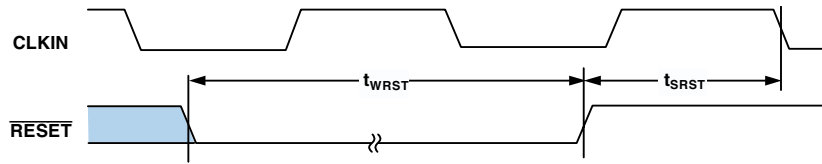

Figure 9. Reset

**Interrupts**

The following timing specification applies to the FLAG0, FLAG1, and FLAG2 pins when they are configured as  $\overline{IRQ0}$ ,  $\overline{IRQ1}$ , and  $\overline{IRQ2}$  interrupts.

**Table 15. Interrupts**

Parameter	Min	Max	Unit
<i>Timing Requirement</i>			
$t_{IPW}$ $\overline{IRQx}$ Pulse Width	$2 \times t_{PCLK} + 2$		ns

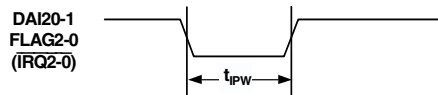

Figure 10. Interrupts

# ADSP-21366

## Core Timer

The following timing specification applies to FLAG3 when it is configured as the core timer (CTIMER).

Table 16. Core Timer

Parameter	Min	Max	Unit
<i>Switching Characteristic</i>			
$t_{WCTIM}$ CTIMER Pulse Width	$2 \times t_{PCLK} - 1$		ns

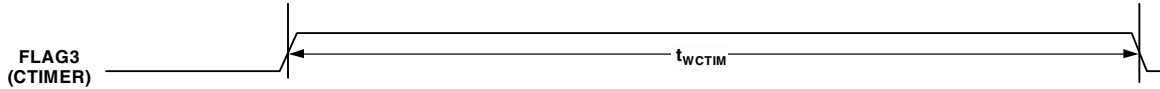

Figure 11. Core Timer

## Timer PWM\_OUT Cycle Timing

The following timing specification applies to Timer0, Timer1, and Timer2 in PWM\_OUT (pulse-width modulation) mode. Timer signals are routed to the DAI\_P20-1 pins through the SRU. Therefore, the timing specifications provided below are valid at the DAI\_P20-1 pins.

Table 17. Timer PWM\_OUT Timing

Parameter	Min	Max	Unit
<i>Switching Characteristic</i>			
$t_{PWMO}$ Timer Pulse Width Output	$2 t_{PCLK} - 1$	$2(2^{31} - 1) t_{PCLK}$	ns

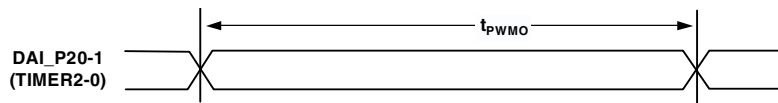

Figure 12. Timer PWM\_OUT Timing

**Timer WDT<sub>H</sub>\_CAP Timing**

The following timing specification applies to Timer0, Timer1, and Timer2 in WDT<sub>H</sub>\_CAP (pulse-width count and capture) mode. Timer signals are routed to the DAI\_P20-1 pins through the SRU. Therefore, the timing specification provided below are valid at the DAI\_P20-1 pins.

**Table 18. Timer Width Capture Timing**

Parameter	Min	Max	Unit
<i>Timing Requirement</i>			
t <sub>PWI</sub> Timer Pulse Width	2 t <sub>PCLK</sub>	2(2 <sup>31</sup> - 1) t <sub>PCLK</sub>	ns

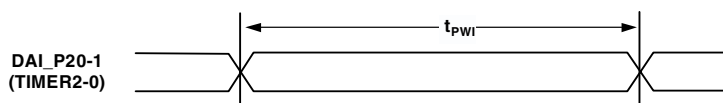

Figure 13. Timer Width Capture Timing

**DAI Pin to Pin Direct Routing**

For direct pin connections only (for example, DAI\_PB01\_I to DAI\_PB02\_O).

**Table 19. DAI Pin to Pin Routing**

Parameter	Min	Max	Unit
<i>Timing Requirement</i>			
t <sub>DPIO</sub> Delay DAI Pin Input Valid to DAI Output Valid	1.5	10	ns

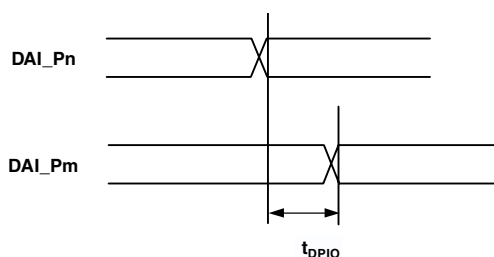

Figure 14. DAI Pin to Pin Direct Routing

# ADSP-21366

## Precision Clock Generator (Direct Pin Routing)

This timing is only valid when the SRU is configured such that the precision clock generator (PCG) takes its inputs directly from the DAI pins (via pin buffers) and sends its outputs directly to the DAI pins. For the other cases, where the PCG's

inputs and outputs are not directly routed to/from DAI pins (via pin buffers) there is no timing data available. All timing parameters and switching characteristics apply to external DAI pins (DAI\_P01 – DAI\_P20).

**Table 20. Precision Clock Generator (Direct Pin Routing)**

Parameter	K and B Grade		W Grade	Unit
	Min	Max	Max	
<i>Timing Requirements</i>				
$t_{PCGIP}$ Input Clock Period	20			ns
$t_{STRIG}$ PCG Trigger Setup Before Falling Edge of PCG Input Clock	4.5			ns
$t_{HTRIG}$ PCG Trigger Hold After Falling Edge of PCG Input Clock	3			ns
<i>Switching Characteristics</i>				
$t_{DPCGIO}$ PCG Output Clock and Frame Sync Active Edge Delay After PCG Input Clock	2.5	10	10	ns
$t_{DTRIGCLK}$ PCG Output Clock Delay After PCG Trigger	$2.5 + ((2.5 + D) \times t_{PCGIP})$	$10 + ((2.5 + D) \times t_{PCGIP})$	$12 + ((2.5 + D) \times t_{PCGIP})$	ns
$t_{DTRIGFS}$ PCG Frame Sync Delay After PCG Trigger	$2.5 + ((2.5 + D - PH) \times t_{PCGIP})$	$10 + ((2.5 + D - PH) \times t_{PCGIP})$	$12 + ((2.5 + D - PH) \times t_{PCGIP})$	ns
$t_{PCGOP}$ Output Clock Period	$2 \times t_{PCGIP}^1$			ns

D = FSxDIV, PH = FSxPHASE. For more information, see the ADSP-21366 SHARC Processor Hardware Reference, "Precision Clock Generators" chapter.

<sup>1</sup>In normal mode,  $t_{PCGOP}(\text{min}) = 2 \times t_{PCGIP}$ .

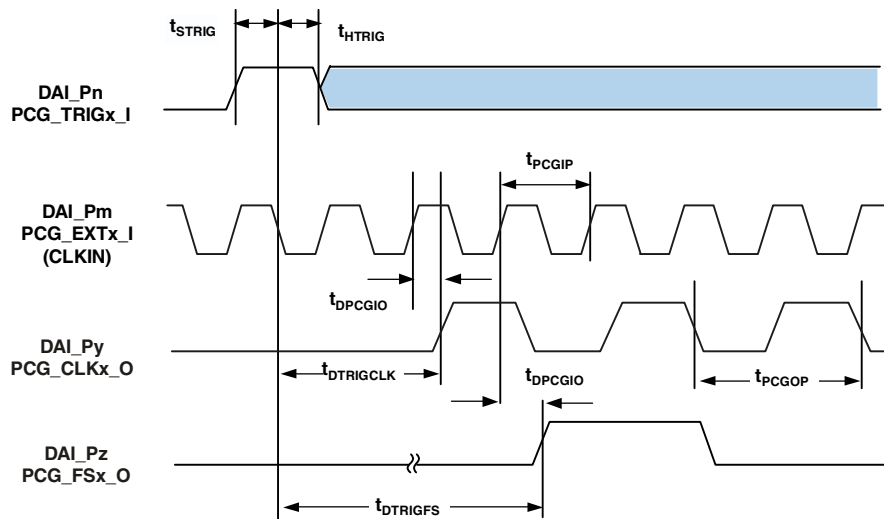

Figure 15. Precision Clock Generator (Direct Pin Routing)

**Flags**

The timing specifications provided below apply to the FLAG3-0 and DAI\_P20-1 pins, the parallel port, and the serial peripheral interface (SPI). See [Table 3, “Pin Descriptions,” on Page 12](#) for more information on flag use.

**Table 21. Flags**

Parameter	Min	Max	Unit
<i>Timing Requirement</i>			
$t_{FIPW}$ FLAG3-0 IN Pulse Width	$2 \times t_{PCLK} + 3$		ns
<i>Switching Characteristic</i>			
$t_{FOPW}$ FLAG3-0 OUT Pulse Width	$2 \times t_{PCLK} - 1$		ns

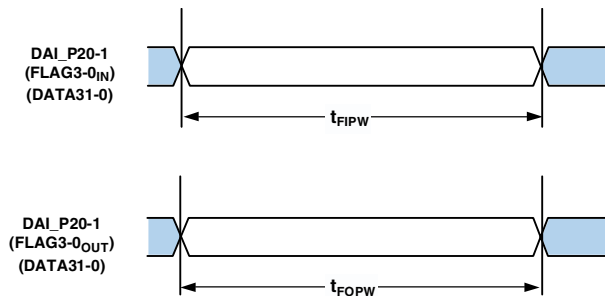

Figure 16. Flags

# ADSP-21366

## Memory Read—Parallel Port

Use these specifications for asynchronous interfacing to memories (and memory-mapped peripherals) when the ADSP-21366 is accessing external memory space.

**Table 22. 8-Bit Memory Read Cycle**

Parameter	K and B Grade		W Grade		Unit
	Min	Max	Min	Max	
<i>Timing Requirements</i>					
$t_{DRS}^1$	AD7–0 Data Setup Before $\overline{RD}$ High		3.3		ns
$t_{DRH}$	AD7–0 Data Hold After $\overline{RD}$ High		0		ns
$t_{DAD}^1$	AD15–8 Address to AD7–0 Data Valid			$D + t_{PCLK} - 5.0$	ns
<i>Switching Characteristics</i>					
$t_{ALEW}$	ALE Pulse Width		$2 \times t_{PCLK} - 2.0$		ns
$t_{ADAS}^2$	AD15–0 Address Setup Before ALE Deasserted		$t_{PCLK} - 2.5$		ns
$t_{RRH}$	Delay Between $\overline{RD}$ Rising Edge to Next Falling Edge		$H + t_{PCLK} - 1.4$		ns
$t_{ALERW}$	ALE Deasserted to Read Asserted		$2 \times t_{PCLK} - 3.8$		ns
$t_{RWALE}$	Read Deasserted to ALE Asserted		$F + H + 0.5$		ns
$t_{ADAH}^2$	AD15–0 Address Hold After ALE Deasserted		$t_{PCLK} - 2.3$		ns
$t_{ALEHZ}^2$	ALE Deasserted to AD7–0 Address in High Z		$t_{PCLK}$	$t_{PCLK} + 3.0$	ns
$t_{RW}$	$\overline{RD}$ Pulse Width		$D - 2.0$		ns
$t_{RDDR}$	AD7–0 ALE Address Drive After Read High		$F + H + t_{PCLK} - 2.3$		ns
$t_{ADRH}$	AD15–8 Address Hold After $\overline{RD}$ High		H		ns
$t_{DAWH}$	AD15–8 Address to $\overline{RD}$ High		$D + t_{PCLK} - 4.0$		ns

$D = (\text{data cycle duration} = \text{the value set by the PPDUR bits (5–1) in the PPCTL register}) \times t_{PCLK}$

$H = t_{PCLK}$  (if a hold cycle is specified, else  $H = 0$ )

$F = 7 \times t_{PCLK}$  (if FLASH\_MODE is set, else  $F = 0$ )

$t_{PCLK} = (\text{peripheral}) \text{ clock period} = 2 \times t_{CCLK}$

<sup>1</sup>The timing specified here is sufficient to satisfy either  $t_{DAD}$  or  $t_{DRS}$  as they are independent.

<sup>2</sup>On reset, ALE is an active high cycle. However, it can be configured by software to be active low.

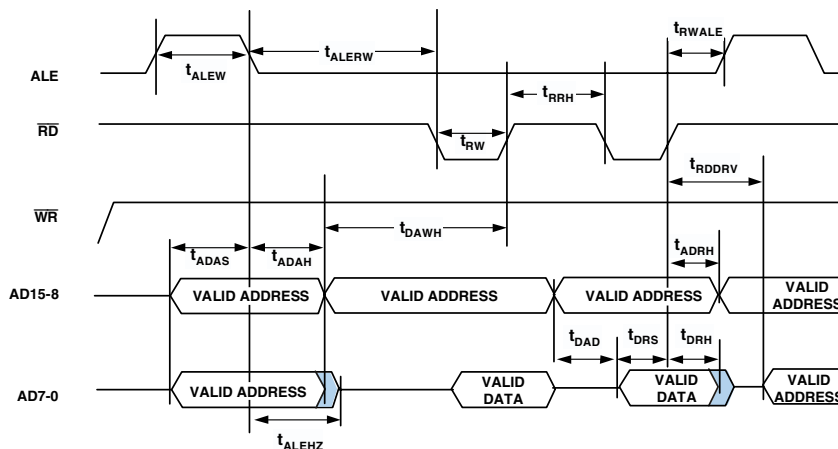

NOTE: MEMORY READS ALWAYS OCCUR IN GROUPS OF FOUR BETWEEN ALE CYCLES. THIS FIGURE ONLY SHOWS TWO MEMORY READS IN ORDER TO PROVIDE THE NECESSARY TIMING INFORMATION.

Figure 17. Read Cycle for 8-Bit Memory Timing



Table 23. 16-Bit Memory Read Cycle

Parameter		K and B Grade		W Grade		Unit
		Min	Max	Min	Max	
<i>Timing Requirements</i>						
t <sub>DRS</sub>	AD15-0 Data Setup Before $\overline{RD}$ High	3.3		4.5		ns
t <sub>DRH</sub>	AD15-0 Data Hold After $\overline{RD}$ High	0		0		ns
<i>Switching Characteristics</i>						
t <sub>ALEW</sub>	ALE Pulse Width	$2 \times t_{PCLK} - 2.0$		$2 \times t_{PCLK} - 2.0$		ns
t <sub>ADAS</sub> <sup>1</sup>	AD15-0 Address Setup Before ALE Deasserted	$t_{PCLK} - 2.5$		$t_{PCLK} - 2.5$		ns
t <sub>ALERW</sub>	ALE Deasserted to Read Asserted	$2 \times t_{PCLK} - 3.8$		$2 \times t_{PCLK} - 3.8$		ns
t <sub>RRH</sub> <sup>2</sup>	Delay Between $\overline{RD}$ Rising Edge to Next Falling Edge	$H + t_{PCLK} - 1.4$		$H + t_{PCLK} - 1.4$		ns
t <sub>RWALE</sub>	Read Deasserted to ALE Asserted	$F + H + 0.5$		$F + H + 0.5$		ns
t <sub>RDDR</sub>	ALE Address Drive After Read High	$F + H + t_{PCLK} - 2.3$		$F + H + t_{PCLK} - 2.3$		ns
t <sub>ADAH</sub> <sup>1</sup>	AD15-0 Address Hold After ALE Deasserted	$t_{PCLK} - 2.3$		$t_{PCLK} - 2.3$		ns
t <sub>ALEHZ</sub> <sup>1</sup>	ALE Deasserted to Address/Data15-0 in High Z	$t_{PCLK}$	$t_{PCLK} + 3.0$	$t_{PCLK}$	$t_{PCLK} + 3.8$	ns
t <sub>RW</sub>	$\overline{RD}$ Pulse Width	$D - 2.0$		$D - 2.0$		ns

D = (data cycle duration = the value set by the PPDUR bits (5-1) in the PPCTL register) × t<sub>PCLK</sub>

H = t<sub>PCLK</sub> (if a hold cycle is specified, else H = 0)

F = 7 × t<sub>PCLK</sub> (if FLASH\_MODE is set, else F = 0)

t<sub>PCLK</sub> = (peripheral) clock period = 2 × t<sub>CCLK</sub>

<sup>1</sup>On reset, ALE is an active high cycle. However, it can be configured by software to be active low.

<sup>2</sup>This parameter is only available when in EMPP = 0 mode.

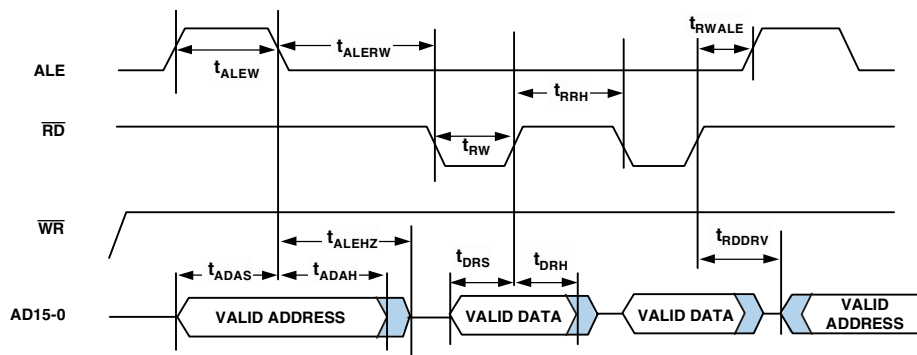

NOTE: FOR 16-BIT MEMORY READS, WHEN EMPP ≠ 0, ONLY ONE  $\overline{RD}$  PULSE OCCURS BETWEEN ALE CYCLES. WHEN EMPP = 0, MULTIPLE  $\overline{RD}$  PULSES OCCUR BETWEEN ALE CYCLES. FOR COMPLETE INFORMATION, SEE THE ADSP-2136X SHARC PROCESSOR HARDWARE REFERENCE.

Figure 18. Read Cycle for 16-Bit Memory Timing

# ADSP-21366

## Memory Write—Parallel Port

Use these specifications for asynchronous interfacing to memories (and memory-mapped peripherals) when the ADSP-21366 is accessing external memory space.

**Table 24. 8-Bit Memory Write Cycle**

Parameter	K and B Grade		W Grade		Unit
	Min	Max	Min	Max	
<i>Switching Characteristics:</i>					
$t_{ALEW}$	ALE Pulse Width		$2 \times t_{PCLK} - 2.0$		ns
$t_{ADAS}^1$	AD15–0 Address Setup Before ALE Deasserted		$t_{PCLK} - 2.8$		ns
$t_{ALERW}$	ALE Deasserted to Write Asserted		$2 \times t_{PCLK} - 3.8$		ns
$t_{RWALE}$	Write Deasserted to ALE Asserted		$H + 0.5$		ns
$t_{WRH}$	Delay Between $\overline{WR}$ Rising Edge to Next $\overline{WR}$ Falling Edge		$F + H + t_{PCLK} - 2.3$		ns
$t_{ADAH}^1$	AD15–0 Address Hold After ALE Deasserted		$t_{PCLK} - 0.5$		ns
$t_{WW}$	$\overline{WR}$ Pulse Width		$D - F - 2.0$		ns
$t_{ADWL}$	AD15–8 Address to $\overline{WR}$ Low		$t_{PCLK} - 2.8$		ns
$t_{ADWH}$	AD15–8 Address Hold After $\overline{WR}$ High		H		ns
$t_{DWS}$	AD7–0 Data Setup Before $\overline{WR}$ High		$D - F + t_{PCLK} - 4.0$		ns
$t_{DWH}$	AD7–0 Data Hold After $\overline{WR}$ High		H		ns
$t_{DAWH}$	AD15–8 Address to $\overline{WR}$ High		$D - F + t_{PCLK} - 4.0$		ns

D = (data cycle duration = the value set by the PPDUR bits (5–1) in the PPCTL register)  $\times$   $t_{PCLK}$ .

H =  $t_{PCLK}$  (if a hold cycle is specified, else H = 0)

F =  $7 \times t_{PCLK}$  (if FLASH\_MODE is set, else F = 0). If FLASH\_MODE is set, D must be  $\geq 9 \times t_{PCLK}$ .

$t_{PCLK}$  = (peripheral) clock period =  $2 \times t_{CCLK}$

<sup>1</sup>On reset, ALE is an active high cycle. However, it can be configured by software to be active low.

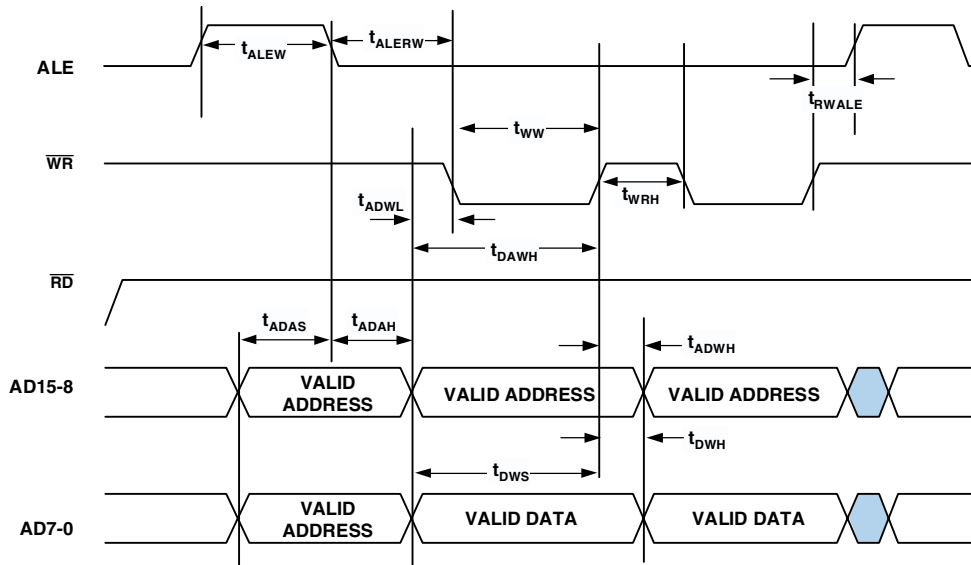

NOTE: MEMORY WRITES ALWAYS OCCUR IN GROUPS OF FOUR BETWEEN ALE CYCLES. THIS FIGURE ONLY SHOWS TWO MEMORY WRITES IN ORDER TO PROVIDE THE NECESSARY TIMING INFORMATION.

Figure 19. Write Cycle for 8-Bit Memory Timing

Table 25. 16-Bit Memory Write Cycle

Parameter		K and B Grade	W Grade	Unit
		Min	Min	
<i>Switching Characteristics</i>				
$t_{ALEW}$	ALE Pulse Width	$2 \times t_{PCLK} - 2.0$	$2 \times t_{PCLK} - 2.0$	ns
$t_{ADAS}^1$	AD15-0 Address Setup Before ALE Deasserted	$t_{PCLK} - 2.5$	$t_{PCLK} - 2.5$	ns
$t_{ALERW}$	ALE Deasserted to Write Asserted	$2 \times t_{PCLK} - 3.8$	$2 \times t_{PCLK} - 3.8$	ns
$t_{RWALE}$	Write Deasserted to ALE Asserted	H + 0.5	H + 0.5	ns
$t_{WRH}^2$	Delay Between $\overline{WR}$ Rising Edge to Next $\overline{WR}$ Falling Edge	F + H + $t_{PCLK} - 2.3$	F + H + $t_{PCLK} - 2.3$	ns
$t_{ADAH}^1$	AD15-0 Address Hold After ALE Deasserted	$t_{PCLK} - 2.3$	$t_{PCLK} - 2.3$	ns
$t_{WW}$	$\overline{WR}$ Pulse Width	D - F - 2.0	D - F - 2.0	ns
$t_{DWS}$	AD15-0 Data Setup Before $\overline{WR}$ High	D - F + $t_{PCLK} - 4.0$	D - F + $t_{PCLK} - 4.0$	ns
$t_{DWH}$	AD15-0 Data Hold After $\overline{WR}$ High	H	H	ns

D = (data cycle duration = the value set by the PPDUR bits (5-1) in the PPCTL register)  $\times t_{PCLK}$ .

H =  $t_{PCLK}$  (if a hold cycle is specified, else H = 0)

F =  $7 \times t_{PCLK}$  (if FLASH\_MODE is set, else F = 0). If FLASH\_MODE is set, D must be  $\geq 9 \times t_{PCLK}$ .

$t_{PCLK}$  = (peripheral) clock period =  $2 \times t_{CCLK}$

<sup>1</sup>On reset, ALE is an active high cycle. However, it can be configured by software to be active low.

<sup>2</sup>This parameter is only available when in EMPP = 0 mode.

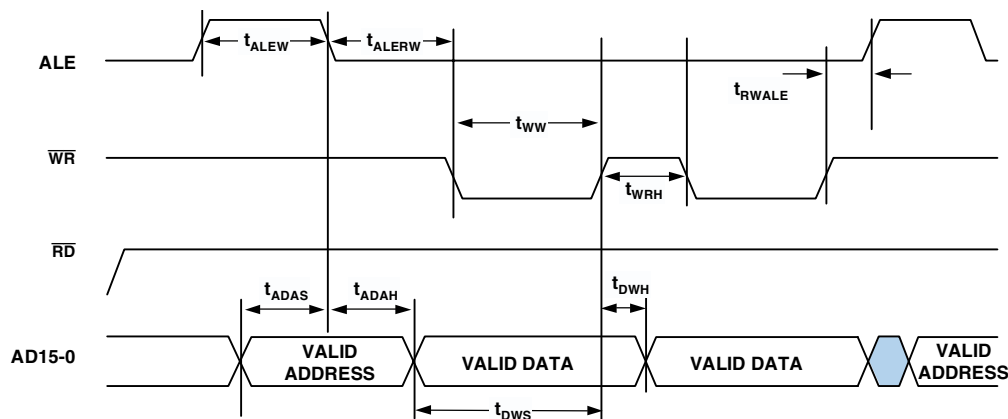

NOTE: FOR 16-BIT MEMORY WRITES, WHEN EMPP = 0, ONLY ONE  $\overline{WR}$  PULSE OCCURS BETWEEN ALE CYCLES. WHEN EMPP = 0, MULTIPLE  $\overline{WR}$  PULSES OCCUR BETWEEN ALE CYCLES. FOR COMPLETE INFORMATION, SEE THE ADSP-2136X SHARC PROCESSOR HARDWARE REFERENCE.

Figure 20. Write Cycle for 16-Bit Memory Timing

# ADSP-21366

## Serial Ports

To determine whether communication is possible between two devices at clock speed  $n$ , the following specifications must be confirmed: 1) frame sync delay and frame sync setup and hold, 2) data delay and data setup and hold, and 3) SCLK width.

Serial port signals (SCLK, FS, data channel A, data channel B) are routed to the DAI\_P20–1 pins using the SRU. Therefore, the timing specifications provided below are valid at the DAI\_P20–1 pins.

**Table 26. Serial Ports—External Clock**

Parameter	K and B Grade		W Grade	Unit	
	Min	Max	Max		
<i>Timing Requirements</i>					
$t_{SFSE}^1$	FS Setup Before SCLK (Externally Generated FS in Either Transmit or Receive Mode)			ns	
$t_{HFSE}^1$	FS Hold After SCLK (Externally Generated FS in Either Transmit or Receive Mode)			ns	
$t_{SDRE}^1$	Receive Data Setup Before Receive SCLK			ns	
$t_{HDRE}^1$	Receive Data Hold After SCLK			ns	
$t_{SCLKW}$	SCLK Width			ns	
$t_{SCLK}$	SCLK Period			ns	
<i>Switching Characteristics</i>					
$t_{DFSE}^2$	FS Delay After SCLK (Internally Generated FS in Either Transmit or Receive Mode)		9.5	11	ns
$t_{HOFSE}^2$	FS Hold After SCLK (Internally Generated FS in Either Transmit or Receive Mode)		2		ns
$t_{DDTE}^2$	Transmit Data Delay After Transmit SCLK		9.5	11	ns
$t_{HDTE}^2$	Transmit Data Hold After Transmit SCLK		2		ns

<sup>1</sup>Referenced to sample edge.

<sup>2</sup>Referenced to drive edge.

**Table 27. Serial Ports—Internal Clock**

Parameter	K and B Grade		W Grade	Unit	
	Min	Max	Max		
<i>Timing Requirements</i>					
$t_{SFSI}^1$	FS Setup Before SCLK (Externally Generated FS in Either Transmit or Receive Mode)			ns	
$t_{HFSI}^1$	FS Hold After SCLK (Externally Generated FS in Either Transmit or Receive Mode)			ns	
$t_{SDRI}^1$	Receive Data Setup Before SCLK			ns	
$t_{HDRI}^1$	Receive Data Hold After SCLK			ns	
<i>Switching Characteristics</i>					
$t_{DFSI}^2$	FS Delay After SCLK (Internally Generated FS in Transmit Mode)		3	3.5	ns
$t_{HOFSI}^2$	FS Hold After SCLK (Internally Generated FS in Transmit Mode)		-1.0		ns
$t_{DFSIR}^2$	FS Delay After SCLK (Internally Generated FS in Receive Mode)		8	9.5	ns
$t_{HOFIR}^2$	FS Hold After SCLK (Internally Generated FS in Receive Mode)		-1.0		ns
$t_{DDTI}^2$	Transmit Data Delay After SCLK		3	4.0	ns
$t_{HDTI}^2$	Transmit Data Hold After SCLK		-1.0		ns
$t_{SCLKIW}$	Transmit or Receive SCLK Width		$0.5t_{SCLK} - 2$	$0.5t_{SCLK} + 2$	ns

<sup>1</sup>Referenced to the sample edge.

<sup>2</sup>Referenced to drive edge.

Table 28. Serial Ports—Enable and Three-State

Parameter	K and B Grade		W Grade	Unit
	Min	Max	Max	
<i>Switching Characteristics</i>				
$t_{DDTEN}^1$ Data Enable from External Transmit SCLK	2			ns
$t_{DDTE}^1$ Data Disable from External Transmit SCLK		7	8.5	ns
$t_{DDTIN}^1$ Data Enable from Internal Transmit SCLK	-1			ns

<sup>1</sup>Referenced to drive edge.

Table 29. Serial Ports—External Late Frame Sync

Parameter	K and B Grade		W Grade	Unit
	Min	Max	Max	
<i>Switching Characteristics</i>				
$t_{DDTLFSE}^1$ Data Delay from Late External Transmit FS or External Receive FS with MCE = 1, MFD = 0		9	10.5	ns
$t_{DDTENFS}^1$ Data Enable for MCE = 1, MFD = 0	0.5			ns

<sup>1</sup>The  $t_{DDTLFSE}$  and  $t_{DDTENFS}$  parameters apply to left-justified sample pair as well as DSP serial mode, and MCE = 1, MFD = 0.

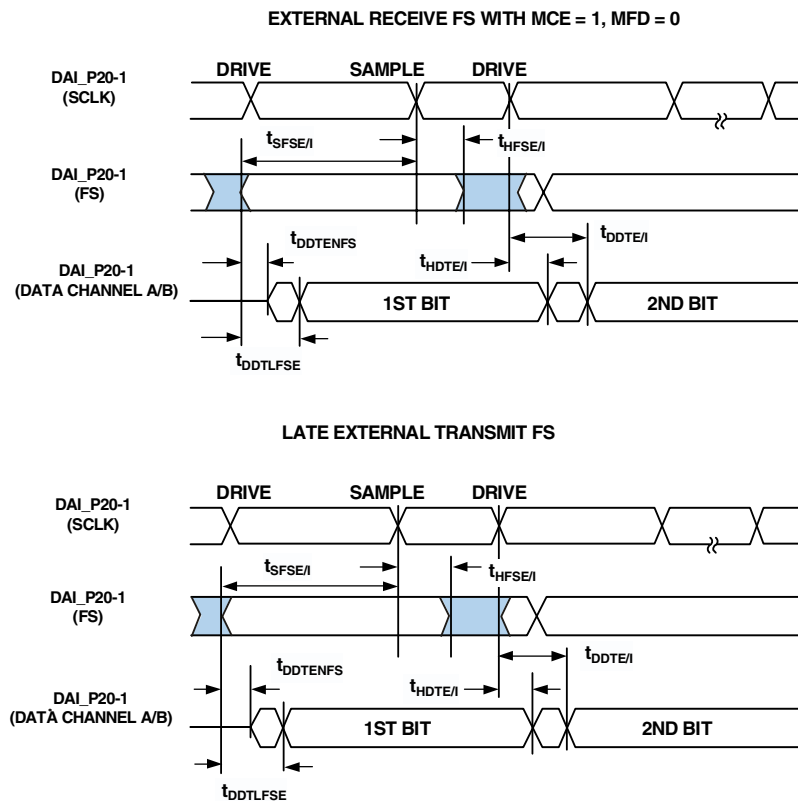

NOTE: SERIAL PORT SIGNALS (SCLK, FS, DATA CHANNEL A/B) ARE ROUTED TO THE DAI\_P20-1 PINS USING THE SRU. THE TIMING SPECIFICATIONS PROVIDED HERE ARE VALID AT THE DAI\_P20-1 PINS.

Figure 21. External Late Frame Sync<sup>1</sup>

<sup>1</sup>This figure reflects changes made to support left-justified sample pair mode.

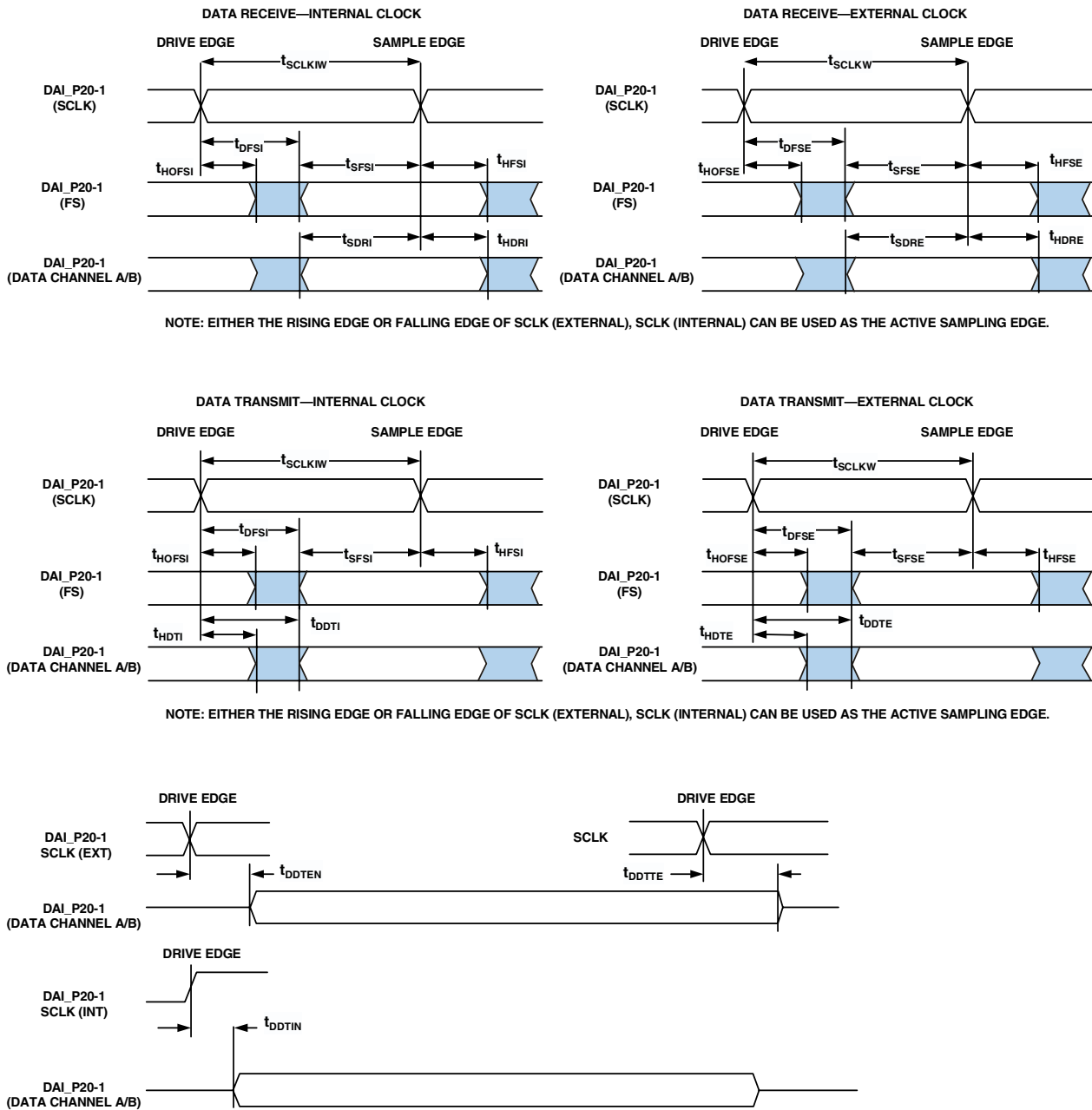

Figure 22. Serial Ports

**Input Data Port (IDP)**

The timing requirements for the IDP are given in Table 30. IDP signals (SCLK, FS, SDATA) are routed to the DAI\_P20-1 pins using the SRU. Therefore, the timing specifications provided below are valid at the DAI\_P20-1 pins.

**Table 30. IDP**

Parameter		Min	Max	Unit
<i>Timing Requirements</i>				
$t_{SISFS}^1$	FS Setup Before SCLK Rising Edge	3		ns
$t_{SIHFS}^1$	FS Hold After SCLK Rising Edge	3		ns
$t_{SISD}^1$	SData Setup Before SCLK Rising Edge	3		ns
$t_{SIHD}^1$	SData Hold After SCLK Rising Edge	3		ns
$t_{DPCLKW}$	Clock Width	9		ns
$t_{DPCLK}$	Clock Period	24		ns

<sup>1</sup> DATA, SCLK, FS can come from any of the DAI pins. SCLK and FS can also come via PCG or SPORTs. PCG's input can be either CLKIN or any of the DAI pins.

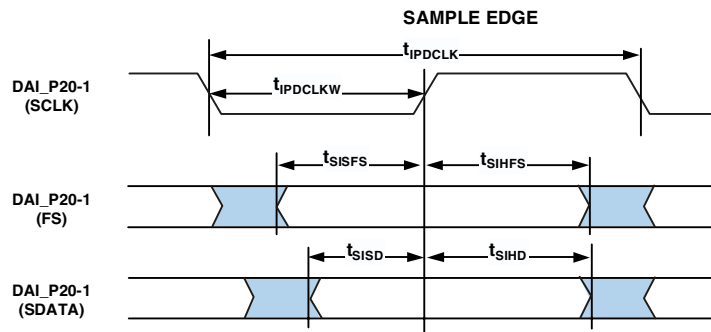

Figure 23. IDP Master Timing

# ADSP-21366

## Parallel Data Acquisition Port (PDAP)

The timing requirements for the PDAP are provided in Table 31. PDAP is the parallel mode operation of Channel 0 of the IDP. For details on the operation of the IDP, see the IDP chapter of the *ADSP-2136x SHARC Processor Hardware Reference for the ADSP-21362/3/4/5/6 Processors*. Note that the most

significant 16 bits of external PDAP data can be provided through either the parallel port AD15–0 or the DAI\_P20–5 pins. The remaining 4 bits can only be sourced through DAI\_P4–1. The timing below is valid at the DAI\_P20–1 pins or at the AD15–0 pins.

**Table 31. Parallel Data Acquisition Port (PDAP)**

Parameter		Min	Max	Unit
<i>Timing Requirements</i>				
$t_{SPCLKEN}^1$	PDAP_CLKEN Setup Before PDAP_CLK Sample Edge	2.5		ns
$t_{HPCLKEN}^1$	PDAP_CLKEN Hold After PDAP_CLK Sample Edge	2.5		ns
$t_{PDSD}^1$	PDAP_DAT Setup Before SCLK PDAP_CLK Sample Edge	3.0		ns
$t_{PDHD}^1$	PDAP_DAT Hold After SCLK PDAP_CLK Sample Edge	2.5		ns
$t_{PDCLKW}$	Clock Width	7.0		ns
$t_{PDCLK}$	Clock Period	24		ns
<i>Switching Characteristics</i>				
$t_{PDHLDD}$	Delay of PDAP Strobe After Last PDAP_CLK Capture Edge for a Word	$2 \times t_{PDCLK} - 1$		ns
$t_{PDSTRB}$	PDAP Strobe Pulse Width	$2 \times t_{PDCLK} - 1.5$		ns

<sup>1</sup> Source pins of DATA are ADDR7–0, DATA7–0, or DAI pins. Source pins for SCLK and FS are: 1) DAI pins, 2) CLKIN through PCG, or 3) DAI pins through PCG.

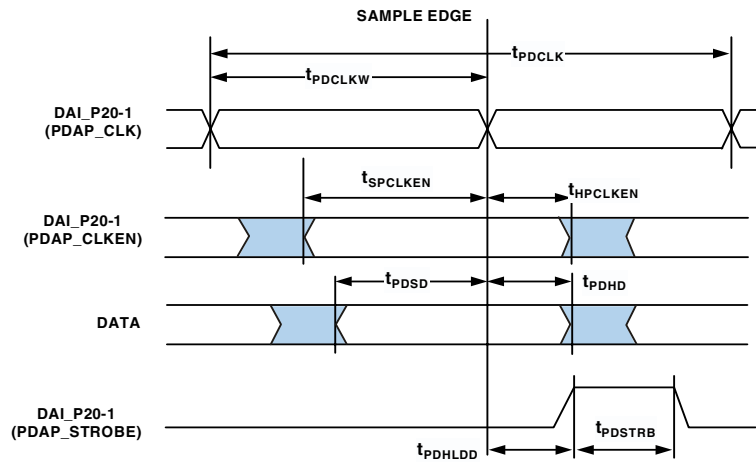

Figure 24. PDAP Timing



**Pulse-Width Modulation Generators**

**Table 32. PWM Timing**

Parameter	Min	Max	Unit
<i>Switching Characteristics</i>			
$t_{PWMW}$ PWM Output Pulse Width	$t_{PCLK} - 2$	$(2^{16} - 2) \times t_{PCLK} - 2$	ns
$t_{PWMP}$ PWM Output Period	$2 \times t_{PCLK} - 1.5$	$(2^{16} - 1) \times t_{PCLK}$	ns

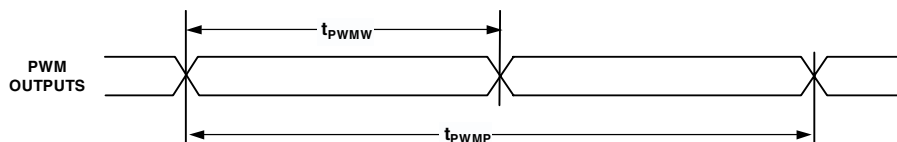

Figure 25. PWM Timing

**Sample Rate Converter—Serial Input Port**

The SRC input signals (SCLK, FS, and SDATA) are routed from the DAI\_P20-1 pins using the SRU. Therefore, the timing specifications provided in Table 33 are valid at the DAI\_P20-1 pins.

**Table 33. SRC, Serial Input Port**

Parameter	Min	Max	Unit
<i>Timing Requirements</i>			
$t_{SRCSFS}^1$ FS Setup Before SCLK Rising Edge	3		ns
$t_{SRCHFS}^1$ FS Hold After SCLK Rising Edge	3		ns
$t_{SRCS}^1$ SData Setup Before SCLK Rising Edge	3		ns
$t_{SRCHD}^1$ SData Hold After SCLK Rising Edge	3		ns
$t_{SRCLKW}$ Clock Width	36		ns
$t_{SRCLK}$ Clock Period	80		ns

<sup>1</sup> DATA, SCLK, FS can come from any of the DAI pins. SCLK and FS can also come via PCG or SPORTs. PCG's input can be either CLKIN or any of the DAI pins.

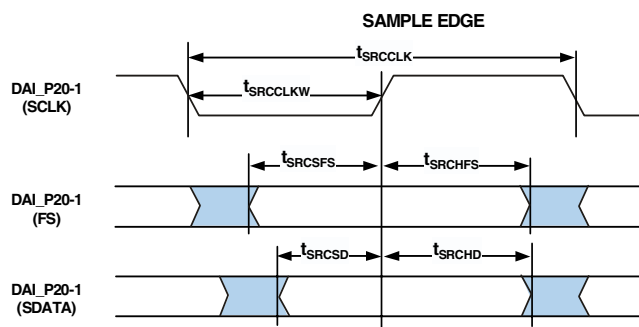

Figure 26. SRC Serial Input Port Timing

# ADSP-21366

## Sample Rate Converter—Serial Output Port

For the serial output port, the frame-sync is an input and should meet setup and hold times with regard to SCLK on the output port. The serial data output, SDATA, has a hold time and delay specification with regard to SCLK. Note that SCLK rising edge is the sampling edge and the falling edge is the drive edge.

**Table 34. SRC, Serial Output Port**

Parameter	K and B Grade		W Grade	Unit
	Min	Max	Max	
<i>Timing Requirements</i>				
$t_{SRCSFS}^1$ FS Setup Before SCLK Rising Edge	3			ns
$t_{SRCHFS}^1$ FS Hold After SCLK Rising Edge	3			ns
<i>Switching Characteristics</i>				
$t_{SRCTDD}^1$ Transmit Data Delay After SCLK Falling Edge		10.5	12.5	ns
$t_{SRCTDH}^1$ Transmit Data Hold After SCLK Falling Edge	2			ns

<sup>1</sup> DATA, SCLK, FS can come from any of the DAI pins. SCLK and FS can also come via PCG or SPORTs. PCG's input can be either CLKIN or any of the DAI pins.

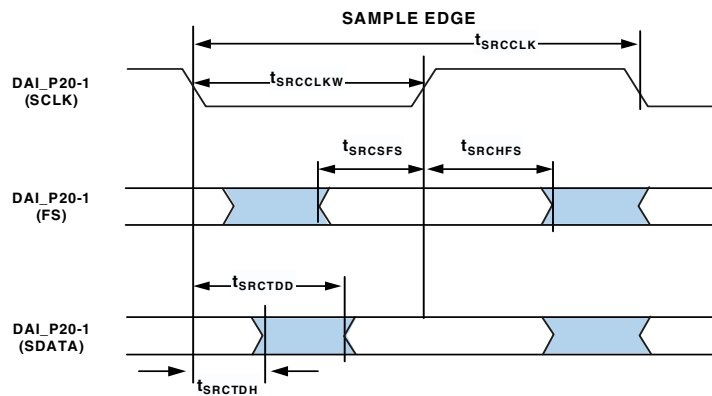

Figure 27. SRC Serial Output Port Timing

**SPDIF Transmitter**

Serial data input to the SPDIF transmitter can be formatted as left-justified, I<sup>2</sup>S, or right-justified with word widths of 16, 18, 20, or 24 bits. The following sections provide timing for the transmitter.

**SPDIF Transmitter—Serial Input Waveforms**

Figure 28 shows the right-justified mode. LRCLK is HI for the left channel and LO for the right channel. Data is valid on the rising edge of SCLK. The MSB is delayed 12-bit clock periods (in 20-bit output mode) or 16-bit clock periods (in 16-bit output

mode) from an LRCLK transition, so that when there are 64 SCLK periods per LRCLK period, the LSB of the data will be right-justified to the next LRCLK transition.

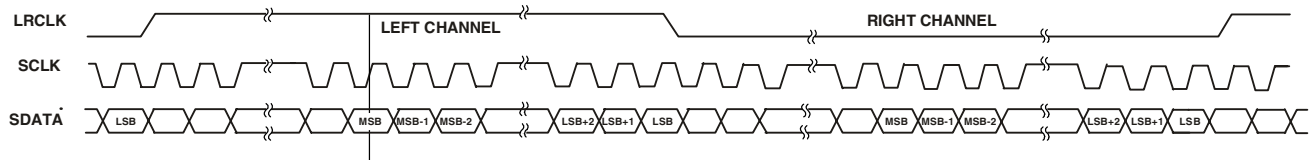

Figure 28. Right-Justified Mode

Figure 29 shows the default I<sup>2</sup>S-justified mode. LRCLK is LO for the left channel and HI for the right channel. Data is valid on the rising edge of SCLK. The MSB is left-justified to an LRCLK transition but with a single SCLK period delay.

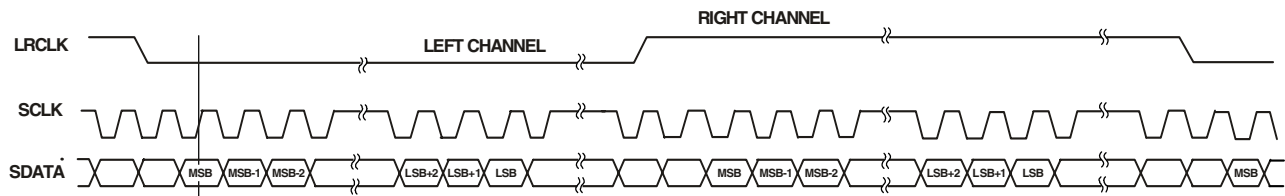

Figure 29. I<sup>2</sup>S-Justified Mode

Figure 30 shows the left-justified mode. LRCLK is HI for the left channel and LO for the right channel. Data is valid on the rising edge of SCLK. The MSB is left-justified to an LRCLK transition with no MSB delay.

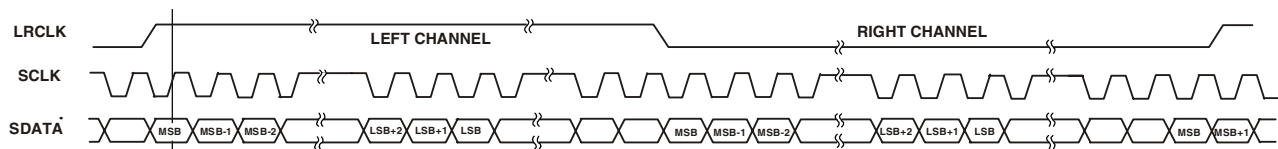

Figure 30. Left-Justified Mode

# ADSP-21366

## SPDIF Transmitter Input Data Timing

The timing requirements for the input port are given in Table 35. Input signals (SCLK, FS, SDATA) are routed to the DAI\_P20-1 pins using the SRU. Therefore, the timing specifications provided below are valid at the DAI\_P20-1 pins.

**Table 35. SPDIF Transmitter Input Data Timing**

Parameter		K and B Grade	W Grade		Unit
		Min	Min	Max	
<i>Timing Requirements</i>					
$t_{SISFS}^1$	FS Setup Before SCLK Rising Edge	3	3		ns
$t_{SIHFS}^1$	FS Hold After SCLK Rising Edge	3	3		ns
$t_{SISD}^1$	SData Setup Before SCLK Rising Edge	3	3		ns
$t_{SIHD}^1$	SData Hold After SCLK Rising Edge	3	3		ns
$t_{SISCLKW}$	Clock Width	36	36		ns
$t_{SISCLK}$	Clock Period	80	80		ns
$t_{SITXCLKW}$	Transmit Clock Width	9	9.5		ns
$t_{SITXCLK}$	Transmit Clock Period	20	20		ns

<sup>1</sup> DATA, SCLK, FS can come from any of the DAI pins. SCLK and FS can also come via PCG or SPORTs. PCG's input can be either CLKIN or any of the DAI pins.

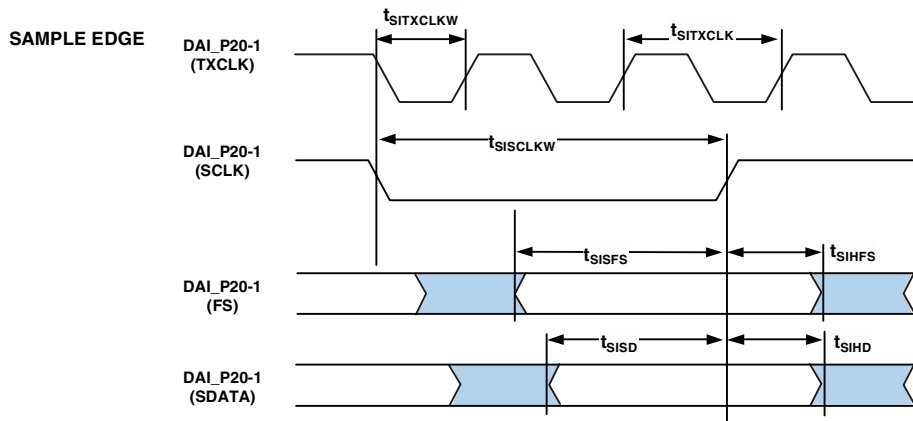

Figure 31. SPDIF Transmitter Input Timing

## Oversampling Clock (TXCLK) Switching Characteristics

SPDIF Transmitter has an over sampling clock. This TXCLK input is divided down to generate the Biphase Clock.

**Table 36. Oversampling Clock (TXCLK) Switching Characteristics**

Parameter	Min	Max	Unit
TXCLK Frequency for TXCLK = 768 × FS		147.5	MHz
TXCLK Frequency for TXCLK = 512 × FS		98.4	MHz
TXCLK Frequency for TXCLK = 384 × FS		73.8	MHz
TXCLK Frequency for TXCLK = 256 × FS		49.2	MHz
Frame Rate		192.0	kHz

**SPDIF Receiver**

The following section describes timing as it relates to the SPDIF receiver.

**Internal Digital PLL Mode**

In the internal digital phase-locked loop mode the internal PLL (digital PLL) generates the  $512 \times F_s$  clock.

**Table 37. SPDIF Receiver Output Timing (Internal Digital PLL Mode)**

Parameter		Min	Max	Unit
<i>Switching Characteristics</i>				
$t_{DFSI}$	LRCLK Delay After SCLK		5	ns
$t_{HOFSI}$	LRCLK Hold After SCLK	-2		ns
$t_{DDTI}$	Transmit Data Delay After SCLK		5	ns
$t_{HDTI}$	Transmit Data Hold After SCLK	-2		ns
$t_{SCLKIW}^1$	Transmit SCLK Width	38		ns
$t_{CCLK}$	Core Clock Period		5	ns

<sup>1</sup>SCLK frequency is  $64 \times F_S$  where  $F_S$  = the frequency of LRCLK.

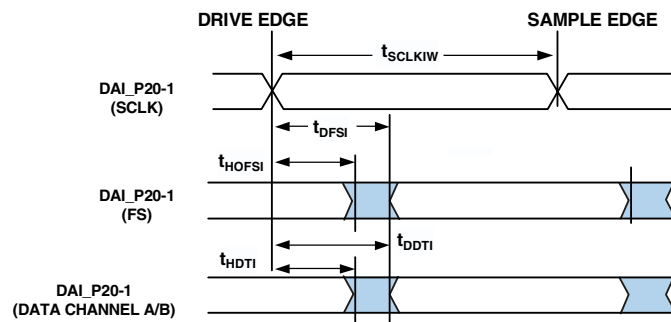

Figure 32. SPDIF Receiver Internal Digital PLL Mode Timing

# ADSP-21366

## SPI Interface—Master

The ADSP-21366 contains two SPI ports. The primary has dedicated pins and the secondary is available through the DAI. The timing provided in [Table 38](#) and [Table 39](#) applies to both.

**Table 38. SPI Interface Protocol—Master Switching and Timing Specifications**

Parameter	K and B Grade		W Grade		Unit
	Min	Max	Min	Max	
<i>Timing Requirements</i>					
t <sub>SSPIDM</sub>	Data Input Valid to SPICLK Edge (Data Input Setup Time)	5.2	6.2		ns
t <sub>SSPIDM</sub>	Data Input Valid to SPICLK Edge (Data Input Setup Time) (SPI2)	8.2	9.5		ns
t <sub>HSPIDM</sub>	SPICLK Last Sampling Edge to Data Input Not Valid	2	2		ns
<i>Switching Characteristics</i>					
t <sub>SPICLKM</sub>	Serial Clock Cycle	8 × t <sub>PCLK</sub> – 2	8 × t <sub>PCLK</sub> – 2		ns
t <sub>SPICHM</sub>	Serial Clock High Period	4 × t <sub>PCLK</sub> – 2	4 × t <sub>PCLK</sub> – 2		ns
t <sub>SPICLM</sub>	Serial Clock Low Period	4 × t <sub>PCLK</sub> – 2	4 × t <sub>PCLK</sub> – 2		ns
t <sub>DDSPIDM</sub>	SPICLK Edge to Data Out Valid (Data Out Delay Time)			3.0	ns
t <sub>DDSPIDM</sub>	SPICLK Edge to Data Out Valid (Data Out Delay Time) (SPI2)			8.0	ns
t <sub>HDSPIDM</sub>	SPICLK Edge to Data Out Not Valid (Data Out Hold Time)	2	2		ns
t <sub>SDSCIM</sub>	FLAG3–0IN (SPI Device Select) Low to First SPICLK Edge	4 × t <sub>PCLK</sub> – 2.5	4 × t <sub>PCLK</sub> – 3.0		ns
t <sub>SDSCIM</sub>	FLAG3–0IN (SPI Device Select) Low to First SPICLK Edge (SPI2)	4 × t <sub>PCLK</sub> – 2.5	4 × t <sub>PCLK</sub> – 3.0		ns
t <sub>HDSM</sub>	Last SPICLK Edge to FLAG3–0IN High	4 × t <sub>PCLK</sub> – 2	4 × t <sub>PCLK</sub> – 2		ns
t <sub>SPITDM</sub>	Sequential Transfer Delay	4 × t <sub>PCLK</sub> – 1	4 × t <sub>PCLK</sub> – 1		ns

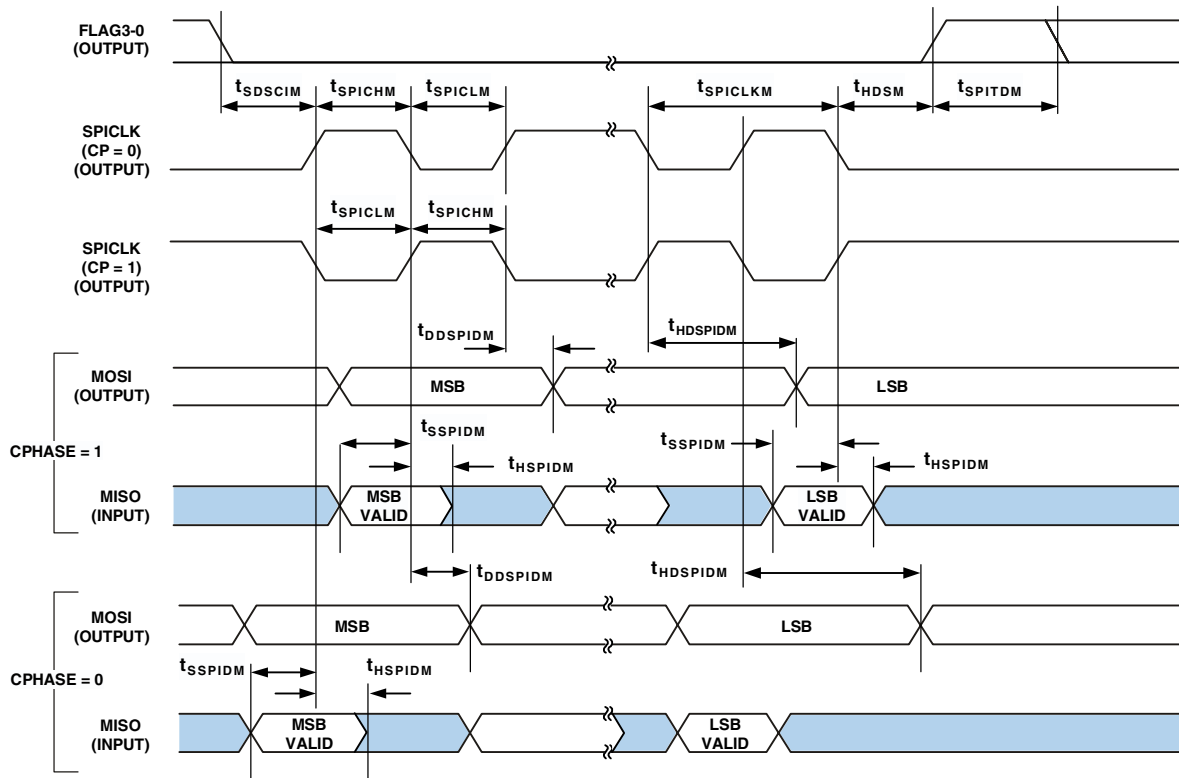

Figure 33. SPI Master Timing

# ADSP-21366

## SPI Interface—Slave

Table 39. SPI Interface Protocol—Slave Switching and Timing Specifications

Parameter		K and B Grade		W Grade	Unit
		Min	Max	Max	
<i>Timing Requirements</i>					
t <sub>SPICLK</sub>	Serial Clock Cycle	4 × t <sub>PCLK</sub> – 2			ns
t <sub>SPICHS</sub>	Serial Clock High Period	2 × t <sub>PCLK</sub> – 2			ns
t <sub>SPICLS</sub>	Serial Clock Low Period	2 × t <sub>PCLK</sub> – 2			ns
t <sub>SDSCO</sub>	$\overline{\text{SPIDS}}$ Assertion to First SPICLK Edge				ns
	CPHASE = 0	2 × t <sub>PCLK</sub>			
	CPHASE = 1	2 × t <sub>PCLK</sub>			
t <sub>HDS</sub>	Last SPICLK Edge to $\overline{\text{SPIDS}}$ Not Asserted, CPHASE = 0	2 × t <sub>PCLK</sub>			ns
t <sub>SSPIDS</sub>	Data Input Valid to SPICLK Edge (Data Input Setup Time)	2			ns
t <sub>HSPIDS</sub>	SPICLK Last Sampling Edge to Data Input Not Valid	2			ns
t <sub>SDPPW</sub>	$\overline{\text{SPIDS}}$ Deassertion Pulse Width (CPHASE = 0)	2 × t <sub>PCLK</sub>			ns
<i>Switching Characteristics</i>					
t <sub>DSOE</sub>	$\overline{\text{SPIDS}}$ Assertion to Data Out Active	0	5	5	ns
t <sub>DSOE</sub> <sup>1</sup>	$\overline{\text{SPIDS}}$ Assertion to Data Out Active (SPI2)	0	8	9	ns
t <sub>DSDHI</sub>	$\overline{\text{SPIDS}}$ Deassertion to Data High Impedance	0	5	5.5	ns
t <sub>DSDHI</sub> <sup>1</sup>	$\overline{\text{SPIDS}}$ Deassertion to Data High Impedance (SPI2)	0	8.6	10	ns
t <sub>DDSPIDS</sub>	SPICLK Edge to Data Out Valid (Data Out Delay Time)			9.5	11.0
t <sub>HDSPIDS</sub>	SPICLK Edge to Data Out Not Valid (Data Out Hold Time)	2 × t <sub>PCLK</sub>			ns
t <sub>DSOV</sub>	$\overline{\text{SPIDS}}$ Assertion to Data Out Valid (CPHASE = 0)			5 × t <sub>PCLK</sub>	5 × t <sub>PCLK</sub>

<sup>1</sup>The timing for these parameters applies when the SPI is routed through the signal routing unit. For more information, see the ADSP-2136x SHARC Processor Hardware Reference for the ADSP-21362/3/4/5/6 Processors, “Serial Peripheral Interface Port” chapter.



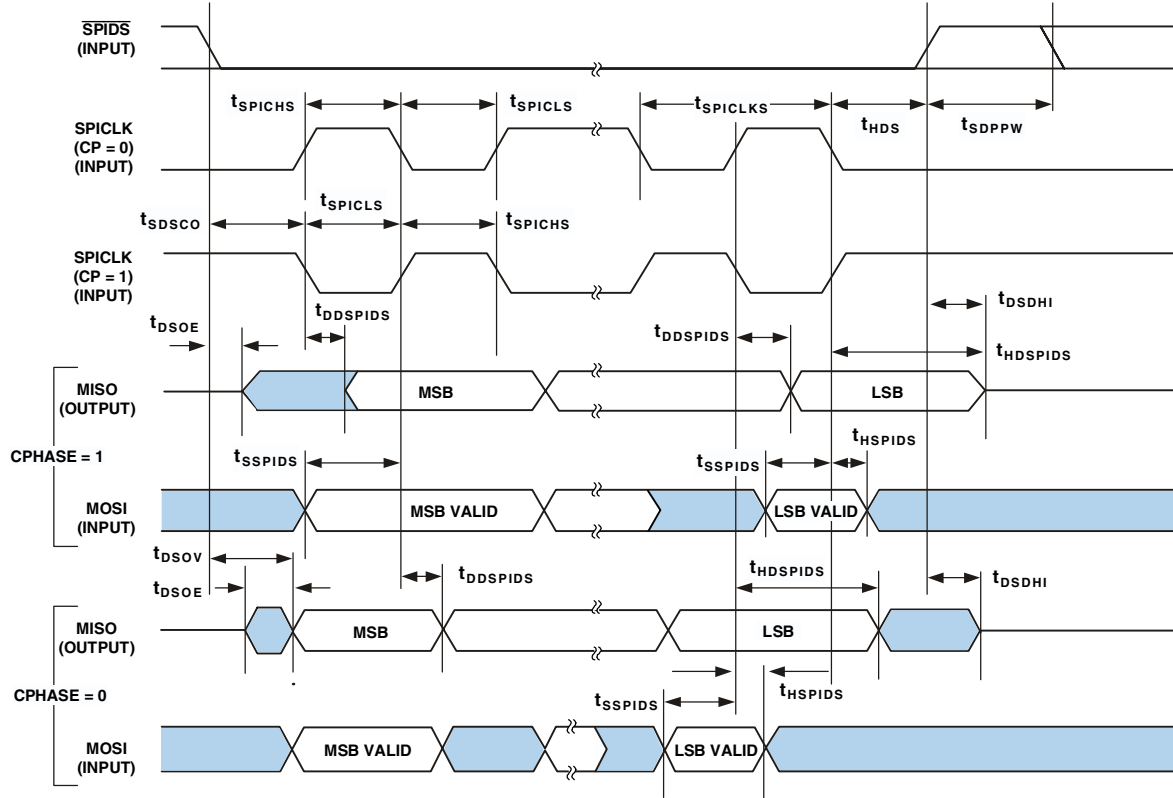

Figure 34. SPI Slave Timing

# ADSP-21366

## JTAG Test Access Port and Emulation

Table 40. JTAG Test Access Port and Emulation

Parameter	Min	Max	Unit
<i>Timing Requirements</i>			
$t_{TCK}$ TCK Period	$t_{CK}$		ns
$t_{STAP}$ TDI, TMS Setup Before TCK High	5		ns
$t_{HTAP}$ TDI, TMS Hold After TCK High	6		ns
$t_{SSYS}^1$ System Inputs Setup Before TCK High	7		ns
$t_{HSYS}^1$ System Inputs Hold After TCK High	18		ns
$t_{TRSTW}$ $\overline{TRST}$ Pulse Width	$4t_{CK}$		ns
<i>Switching Characteristics</i>			
$t_{DTDO}$ TDO Delay from TCK Low		7	ns
$t_{DSYS}^2$ System Outputs Delay After TCK Low		$t_{CK} \div 2 + 7$	ns

<sup>1</sup>System Inputs = AD15-0,  $\overline{SPIDS}$ , CLKCFG1-0,  $\overline{RESET}$ , BOOTCFG1-0, MISO, MOSI, SPICLK, DAI\_Px, FLAG3-0.

<sup>2</sup>System Outputs = MISO, MOSI, SPICLK, DAI\_Px, AD15-0,  $\overline{RD}$ ,  $\overline{WR}$ , FLAG3-0, CLKOUT,  $\overline{EMU}$ , ALE.

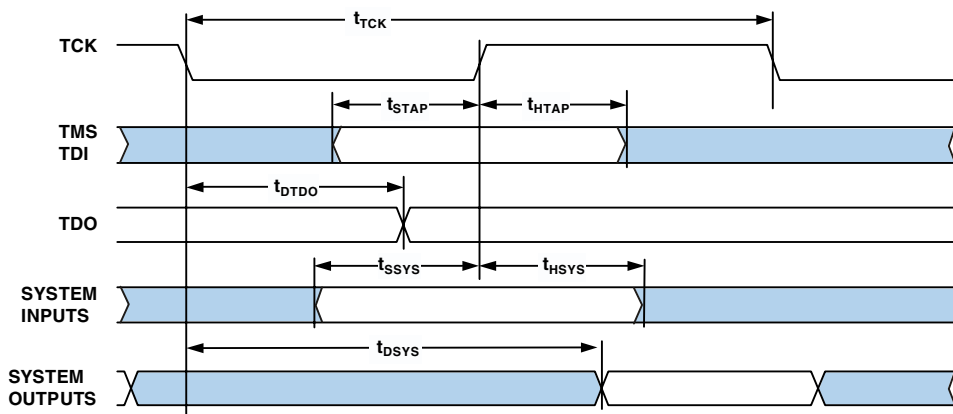

Figure 35. IEEE 1149.1 JTAG Test Access Port

**OUTPUT DRIVE CURRENTS**

Figure 36 shows typical I-V characteristics for the output drivers of the ADSP-21366. The curves represent the current drive capability of the output drivers as a function of output voltage.

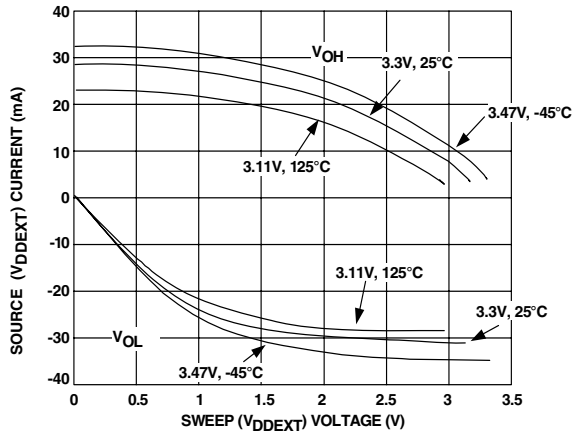

Figure 36. ADSP-21366 Typical Drive

**TEST CONDITIONS**

The ac signal specifications (timing parameters) appear in Table 14 on Page 21 through Table 40 on Page 44. These include output disable time, output enable time, and capacitive loading. The timing specifications for the SHARC apply for the voltage reference levels in Figure 37.

Timing is measured on signals when they cross the 1.5 V level as described in Figure 38. All delays (in nanoseconds) are measured between the point that the first signal reaches 1.5 V and the point that the second signal reaches 1.5 V.

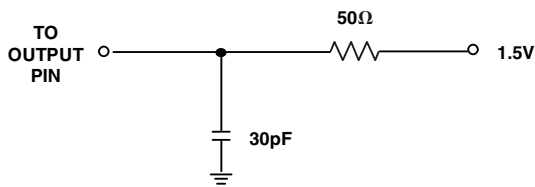

Figure 37. Equivalent Device Loading for AC Measurements (Includes All Fixtures)



Figure 38. Voltage Reference Levels for AC Measurements

**CAPACITIVE LOADING**

Output delays and holds are based on standard capacitive loads: 30 pF on all pins (see Figure 37). Figure 41 shows graphically how output delays and holds vary with load capacitance. The graphs of Figure 39, Figure 40, and Figure 41 may not be linear outside the ranges shown for Typical Output Delay vs. Load Capacitance and Typical Output Rise Time (20%–80%, V = Min) vs. Load Capacitance.

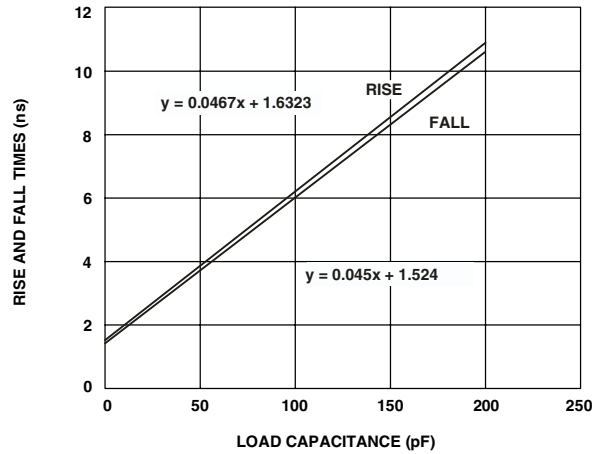

Figure 39. Typical Output Rise/Fall Time (20%–80%, VDDEXT = Max)

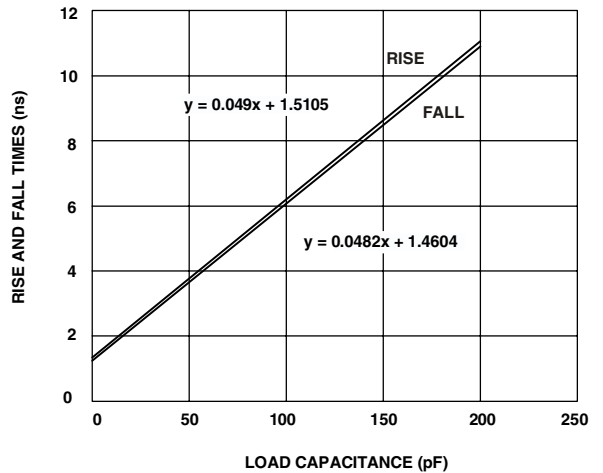

Figure 40. Typical Output Rise/Fall Time (20%–80%, VDDEXT = Min)

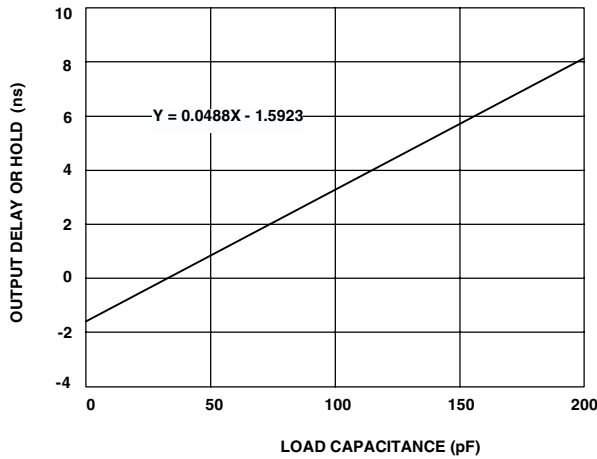

Figure 41. Typical Output Delay or Hold vs. Load Capacitance (at Ambient Temperature)

## THERMAL CHARACTERISTICS

The ADSP-21366 processor is rated for performance over the temperature range specified in [Recommended Operating Conditions on Page 16](#).

Table 41 through Table 44 airflow measurements comply with JEDEC standards JESD51-2 and JESD51-6 and the junction-to-board measurement complies with JESD51-8. Test board and thermal via design comply with JEDEC standards JESD51-9 (BGA). The junction-to-case measurement complies with MIL-STD-883. All measurements use a 2S2P JEDEC test board.

Industrial applications using the BGA package require thermal vias, to an embedded ground plane, in the PCB. Refer to JEDEC standard JESD51-9 for printed circuit board thermal ball land and thermal via design information.

To determine the junction temperature of the device while on the application PCB, use:

$$T_J = T_T + (\Psi_{JT} \times P_D)$$

where:

$T_J$  = junction temperature (°C)

$T_T$  = case temperature (°C) measured at the top center of the package

$\Psi_{JT}$  = junction-to-top (of package) characterization parameter is the typical value from [Table 41](#) and [Table 43](#).

$P_D$  = power dissipation (see EE Note No. EE-277 for more information).

Values of  $\theta_{JA}$  are provided for package comparison and PCB design considerations.

Values of  $\theta_{JC}$  are provided for package comparison and PCB design considerations when an external heat sink is required. Note that the thermal characteristics values provided in [Table 41](#) through [Table 44](#) are modeled values.

Table 41. Thermal Characteristics for BGA (No thermal vias in PCB)

Parameter	Condition	Typical	Unit
$\theta_{JA}$	Airflow = 0 m/s	25.40	°C/W
$\theta_{JMA}$	Airflow = 1 m/s	21.90	°C/W
$\theta_{JMA}$	Airflow = 2 m/s	20.90	°C/W
$\theta_{JC}$		5.07	°C/W
$\Psi_{JT}$	Airflow = 0 m/s	0.140	°C/W
$\Psi_{JMT}$	Airflow = 1 m/s	0.330	°C/W
$\Psi_{JMT}$	Airflow = 2 m/s	0.410	°C/W

Table 42. Thermal Characteristics for BGA (Thermal vias in PCB)

Parameter	Condition	Typical	Unit
$\theta_{JA}$	Airflow = 0 m/s	23.40	°C/W
$\theta_{JMA}$	Airflow = 1 m/s	20.00	°C/W
$\theta_{JMA}$	Airflow = 2 m/s	19.20	°C/W
$\theta_{JC}$		5.00	°C/W
$\Psi_{JT}$	Airflow = 0 m/s	0.130	°C/W
$\Psi_{JMT}$	Airflow = 1 m/s	0.300	°C/W
$\Psi_{JMT}$	Airflow = 2 m/s	0.360	°C/W

Table 43. Thermal Characteristics for LQFP (with heat slug not soldered to PCB)

Parameter	Condition	Typical	Unit
$\theta_{JA}$	Airflow = 0 m/s	26.08	°C/W
$\theta_{JMA}$	Airflow = 1 m/s	24.59	°C/W
$\theta_{JMA}$	Airflow = 2 m/s	23.77	°C/W
$\theta_{JC}$		6.83	°C/W
$\Psi_{JT}$	Airflow = 0 m/s	0.236	°C/W
$\Psi_{JMT}$	Airflow = 1 m/s	0.427	°C/W
$\Psi_{JMT}$	Airflow = 2 m/s	0.441	°C/W

Table 44. Thermal Characteristics for LQFP (with heat slug soldered to PCB)

Parameter	Condition	Typical	Unit
$\theta_{JA}$	Airflow = 0 m/s	16.50	°C/W
$\theta_{JMA}$	Airflow = 1 m/s	15.14	°C/W
$\theta_{JMA}$	Airflow = 2 m/s	14.35	°C/W
$\theta_{JC}$		6.83	°C/W
$\Psi_{JT}$	Airflow = 0 m/s	0.129	°C/W
$\Psi_{JMT}$	Airflow = 1 m/s	0.255	°C/W
$\Psi_{JMT}$	Airflow = 2 m/s	0.261	°C/W

## 136-BALL BGA PIN CONFIGURATIONS

The following table shows the ADSP-21366's pin names and their default function after reset (in parentheses).

**Table 45. BGA Pin Assignments**

Ball Name	Ball No.	Ball Name	Ball No.	Pin Name	Ball No.	Pin Name	Ball No.
CLKCFG0	A01	CLKCFG1	B01	BOOTCFG1	C01	V <sub>DDINT</sub>	D01
XTAL	A02	GND	B02	BOOTCFG0	C02	GND	D02
TMS	A03	V <sub>DDEXT</sub>	B03	GND	C03	GND	D04
TCK	A04	CLKIN	B04	GND	C12	GND	D05
TDI	A05	TRST	B05	GND	C13	GND	D06
CLKOUT	A06	A <sub>VSS</sub>	B06	V <sub>DDINT</sub>	C14	GND	D09
TDO	A07	A <sub>VDD</sub>	B07			GND	D10
EMU	A08	V <sub>DDEXT</sub>	B08			GND	D11
MOSI	A09	SPICLK	B09			GND	D13
MISO	A10	RESE $\bar{T}$	B10			V <sub>DDINT</sub>	D14
SPIDS	A11	V <sub>DDINT</sub>	B11				
V <sub>DDINT</sub>	A12	GND	B12				
GND	A13	GND	B13				
GND	A14	GND	B14				
V <sub>DDINT</sub>	E01	FLAG1	F01	AD7	G01	AD6	H01
GND	E02	FLAG0	F02	V <sub>DDINT</sub>	G02	V <sub>DDEXT</sub>	H02
GND	E04	GND	F04	V <sub>DDEXT</sub>	G13	DAI_P18 (SD5B)	H13
GND	E05	GND	F05	DAI_P19 (SCLK45)	G14	DAI_P17 (SD5A)	H14
GND	E06	GND	F06				
GND	E09	GND	F09				
GND	E10	GND	F10				
GND	E11	GND	F11				
GND	E13	FLAG2	F13				
FLAG3	E14	DAI_P20 (SFS45)	F14				

# ADSP-21366

Table 45. BGA Pin Assignments (Continued)

Ball Name	Ball No.	Ball Name	Ball No.	Pin Name	Ball No.	Pin Name	Ball No.
AD5	J01	AD3	K01	AD2	L01	AD0	M01
AD4	J02	V <sub>DDINT</sub>	K02	AD1	L02	$\overline{WR}$	M02
GND	J04	GND	K04	GND	L04	GND	M03
GND	J05	GND	K05	GND	L05	GND	M12
GND	J06	GND	K06	GND	L06	DAI_P12 (SD3B)	M13
GND	J09	GND	K09	GND	L09	DAI_P13 (SCLK23)	M14
GND	J10	GND	K10	GND	L10		
GND	J11	GND	K11	GND	L11		
V <sub>DDINT</sub>	J13	GND	K13	GND	L13		
DAI_P16 (SD4B)	J14	DAI_P15 (SD4A)	K14	DAI_P14 (SFS23)	L14		
AD15	N01	AD14	P01				
ALE	N02	AD13	P02				
$\overline{RD}$	N03	AD12	P03				
V <sub>DDINT</sub>	N04	AD11	P04				
V <sub>DDEXT</sub>	N05	AD10	P05				
AD8	N06	AD9	P06				
V <sub>DDINT</sub>	N07	DAI_P1 (SD0A)	P07				
DAI_P2 (SD0B)	N08	DAI_P3 (SCLK0)	P08				
V <sub>DDEXT</sub>	N09	DAI_P5 (SD1A)	P09				
DAI_P4 (SFS0)	N10	DAI_P6 (SD1B)	P10				
V <sub>DDINT</sub>	N11	DAI_P7 (SCLK1)	P11				
V <sub>DDINT</sub>	N12	DAI_P8 (SFS1)	P12				
GND	N13	DAI_P9 (SD2A)	P13				
DAI_P10 (SD2B)	N14	DAI_P11 (SD3A)	P14				

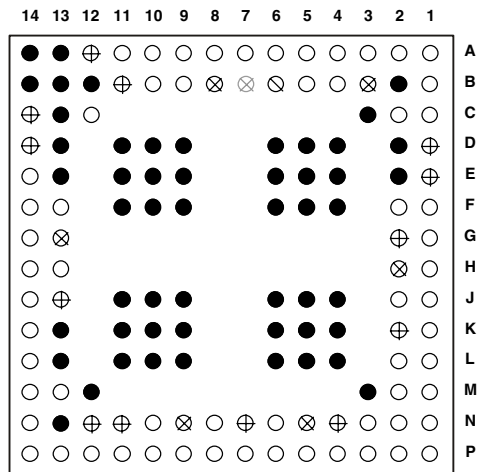

KEY

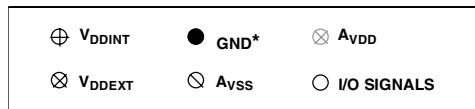

\*USE THE CENTER BLOCK OF GROUND PINS TO PROVIDE THERMAL PATHWAYS TO YOUR PRINTED CIRCUIT BOARD'S GROUND PLANE.

Figure 42. BGA Pin Assignments (Bottom View, Summary)

# ADSP-21366

## 144-LEAD LQFP PIN CONFIGURATIONS

The following table shows the ADSP-21366's pin names and their default function after reset (in parentheses).

Table 46. LQFP Pin Assignments

Pin Name	Pin No.	Pin Name	Pin No.	Pin Name	Pin No.	Pin Name	Pin No.
V <sub>DDINT</sub>	1	V <sub>DDINT</sub>	37	V <sub>DDEXT</sub>	73	GND	109
CLKCFG0	2	GND	38	GND	74	V <sub>DDINT</sub>	110
CLKCFG1	3	$\overline{\text{RD}}$	39	V <sub>DDINT</sub>	75	GND	111
BOOTCFG0	4	ALE	40	GND	76	V <sub>DDINT</sub>	112
BOOTCFG1	5	AD15	41	DAI_P10 (SD2B)	77	GND	113
GND	6	AD14	42	DAI_P11 (SD3A)	78	V <sub>DDINT</sub>	114
V <sub>DDEXT</sub>	7	AD13	43	DAI_P12 (SD3B)	79	GND	115
GND	8	GND	44	DAI_P13 (SCLK23)	80	V <sub>DDEXT</sub>	116
V <sub>DDINT</sub>	9	V <sub>DDEXT</sub>	45	DAI_P14 (SFS23)	81	GND	117
GND	10	AD12	46	DAI_P15 (SD4A)	82	V <sub>DDINT</sub>	118
V <sub>DDINT</sub>	11	V <sub>DDINT</sub>	47	V <sub>DDINT</sub>	83	GND	119
GND	12	GND	48	GND	84	V <sub>DDINT</sub>	120
V <sub>DDINT</sub>	13	AD11	49	GND	85	$\overline{\text{RESET}}$	121
GND	14	AD10	50	DAI_P16 (SD4B)	86	$\overline{\text{SPIDS}}$	122
FLAG0	15	AD9	51	DAI_P17 (SD5A)	87	GND	123
FLAG1	16	AD8	52	DAI_P18 (SD5B)	88	V <sub>DDINT</sub>	124
AD7	17	DAI_P1 (SD0A)	53	DAI_P19 (SCLK45)	89	SPICLK	125
GND	18	V <sub>DDINT</sub>	54	V <sub>DDINT</sub>	90	MISO	126
V <sub>DDINT</sub>	19	GND	55	GND	91	MOSI	127
GND	20	DAI_P2 (SD0B)	56	GND	92	GND	128
V <sub>DDEXT</sub>	21	DAI_P3 (SCLK0)	57	V <sub>DDEXT</sub>	93	V <sub>DDINT</sub>	129
GND	22	GND	58	DAI_P20 (SFS45)	94	V <sub>DDEXT</sub>	130
V <sub>DDINT</sub>	23	V <sub>DDEXT</sub>	59	GND	95	A <sub>VDD</sub>	131
AD6	24	V <sub>DDINT</sub>	60	V <sub>DDINT</sub>	96	A <sub>VSS</sub>	132
AD5	25	GND	61	FLAG2	97	GND	133
AD4	26	DAI_P4 (SFS0)	62	FLAG3	98	CLKOUT	134
V <sub>DDINT</sub>	27	DAI_P5 (SD1A)	63	V <sub>DDINT</sub>	99	$\overline{\text{EMU}}$	135
GND	28	DAI_P6 (SD1B)	64	GND	100	TDO	136
AD3	29	DAI_P7 (SCLK1)	65	V <sub>DDINT</sub>	101	TDI	137
AD2	30	V <sub>DDINT</sub>	66	GND	102	$\overline{\text{TRST}}$	138
V <sub>DDEXT</sub>	31	GND	67	V <sub>DDINT</sub>	103	TCK	139
GND	32	V <sub>DDINT</sub>	68	GND	104	TMS	140
AD1	33	GND	69	V <sub>DDINT</sub>	105	GND	141
AD0	34	DAI_P8 (SFS1)	70	GND	106	CLKIN	142
$\overline{\text{WR}}$	35	DAI_P9 (SD2A)	71	V <sub>DDINT</sub>	107	XTAL	143
V <sub>DDINT</sub>	36	V <sub>DDINT</sub>	72	V <sub>DDINT</sub>	108	V <sub>DDEXT</sub>	144



### OUTLINE DIMENSIONS

The ADSP-21366 is available in a 136-ball BGA package and a 144-lead integrated heat sink LQFP package.

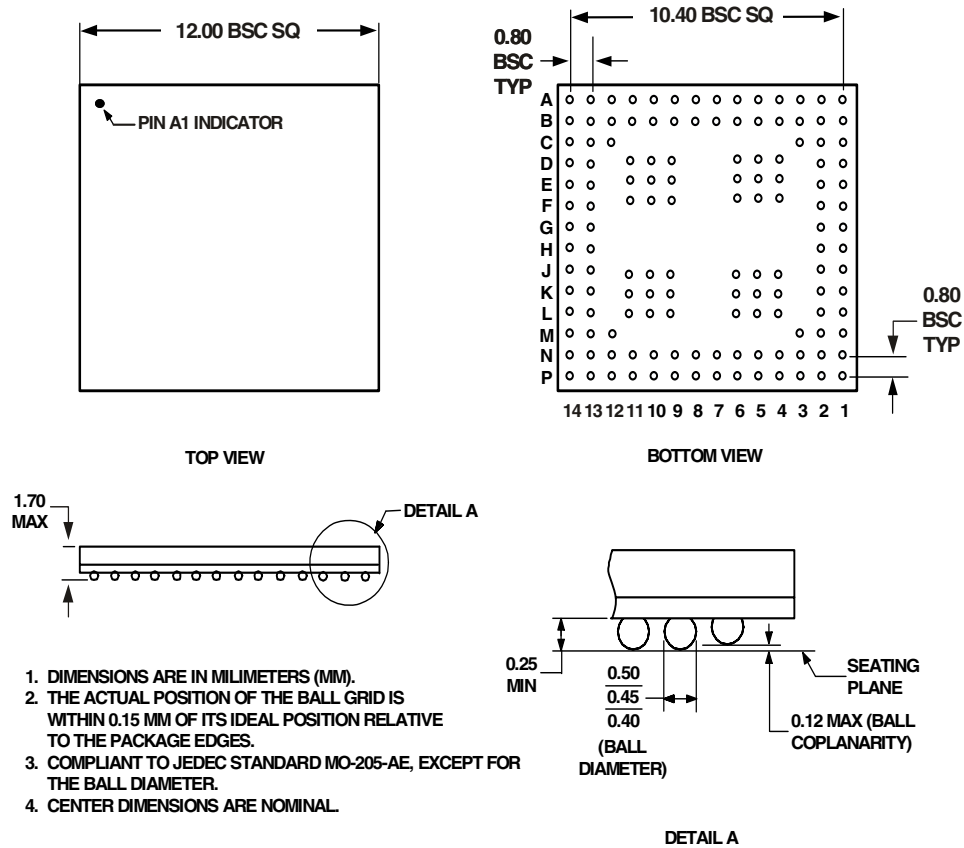

Figure 43. 136-Lead Chip Scale Package Ball Grid Array [CSP\_BGA](BC-136-2)

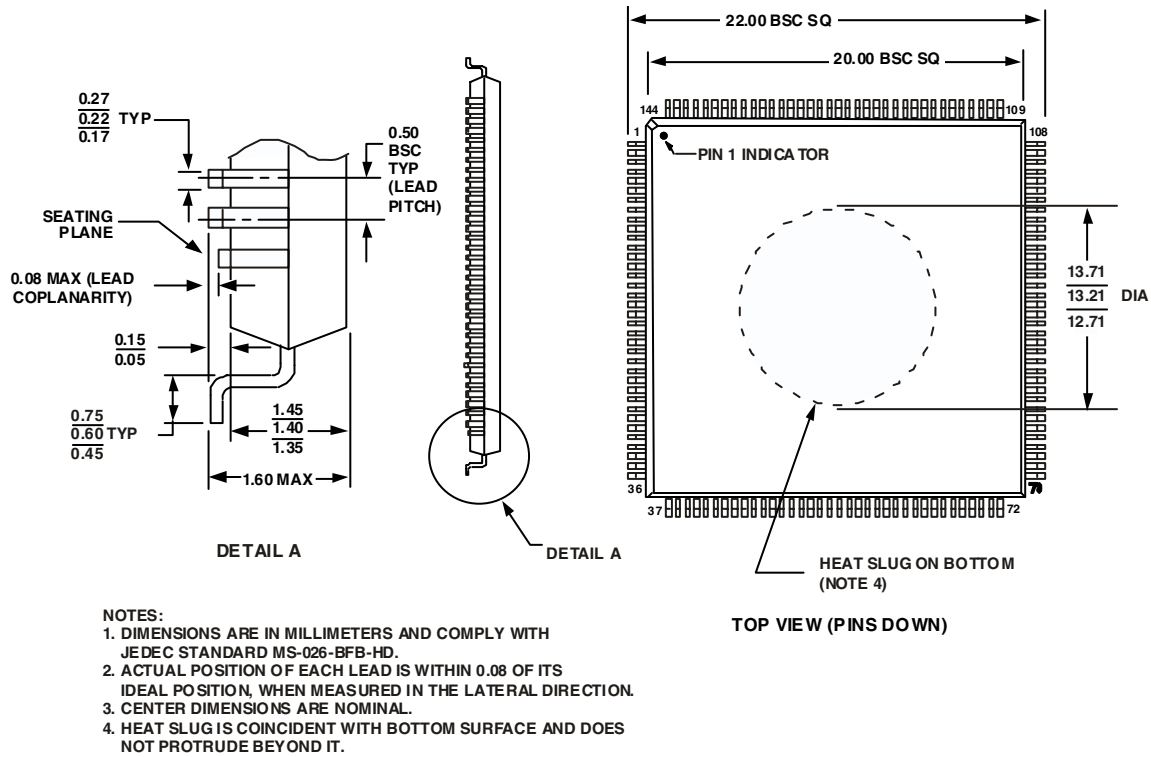

Figure 44. 144-Lead Low Profile Quad Flat Package, with Integrated Heatsink [LQFP\_INT\_HS] (SQ-144-3)

## SURFACE MOUNT DESIGN

The following table is provided as an aide to PCB design. The numbers listed in the table are for reference purposes and should not supersede the PCB design rules. Please reference IPC-7351, *Surface Mount Design and Land Pattern Standard*, for PCB design recommendations.

Package	Ball Attach Type	Solder Mask Opening	Ball Pad Size
136-Lead Ball Grid Array BGA (BC-136-2)	Solder Mask Defined (SMD)	0.40	0.53

## ORDERING GUIDE

Analog Devices offers a wide variety of audio algorithms and combinations to run on the ADSP-21366 processor. These products are sold as part of a chipset, bundled with necessary application software under special part numbers. For a complete list, visit our website at [www.analog.com/SHARC](http://www.analog.com/SHARC).

These products also may contain 3rd party IPs that may require users to have authorization from the respective IP holders to receive them. Royalty for use of the 3rd party IPs may also be payable by users.

Model	Temperature Range <sup>1</sup>	Instruction Rate	On-Chip SRAM	ROM	Operating Voltage Internal/External	Package Description	Package Option
ADSP-21366KBC-1AA	0 to 70°C	333 MHz	3M Bit	4M Bit	1.2 V/3.3 V	136-ball CSP-BGA	BC-136-2
ADSP-21366KBCZ-1AA <sup>2</sup>	0 to 70°C	333 MHz	3M Bit	4M Bit	1.2 V/3.3 V	136-ball CSP-BGA	BC-136-2
ADSP-21366KSQZ-1AA <sup>2</sup>	0 to 70°C	333 MHz	3M Bit	4M Bit	1.2 V/3.3 V	144-lead LQFP_INT_HS	SQ-144-3
ADSP-21366BBC-1AA	-40 to +85°C	333 MHz	3M Bit	4M Bit	1.2 V/3.3 V	136-ball CSP-BGA	BC-136-2
ADSP-21366BBCZ-1AA <sup>2</sup>	-40 to +85°C	333 MHz	3M Bit	4M Bit	1.2 V/3.3 V	136-ball CSP-BGA	BC-136-2
ADSP-21366BSQZ-1AA <sup>2</sup>	-40 to +85°C	333 MHz	3M Bit	4M Bit	1.2 V/3.3 V	144-lead LQFP_INT_HS	SQ-144-3
ADSP-21366WSQZ-2AA <sup>2</sup>	-40 to +105°C	200 MHz	3M Bit	4M Bit	1.0 V/3.3 V	144-lead LQFP_INT_HS	SQ-144-3

<sup>1</sup>Referenced temperature is ambient temperature.

<sup>2</sup>Z = Pb-free package.





