

16-bit Microcontroller

CMOS

F²MC-16LX MB90340E Series

MB90341E(S)/341CE(S)/342E(S)/342CE(S)/F342E(S)/F342CE(S)/F343E(S)/F343CE(S)/F345E(S)/
MB90F345CE(S)/346E(S)/346CE(S)/F346E(S)/F346CE(S)/347E(S)/347CE(S)/F347E(S)/F347CE(S)/
MB90348E(S)/348CE(S)/349E(S)/349CE(S)/F349E(S)/F349CE(S)/V340E-101/V340E-102

■ DESCRIPTION

The MB90340E series with up to 2 FULL-CAN* interfaces is especially designed for automotive and other industrial applications. Its main feature are the on-board CAN Interfaces, which conform to V2.0 Part A and Part B, while supporting a very flexible message buffer scheme and so offering more functions than a normal full CAN approach.

The power to the MCU core (3 V) is supplied by a built-in regulator circuit, giving these microcontrollers superior performance in terms of power consumption and tolerance to EMI.

* : Controller Area Network (CAN) - License of Robert Bosch GmbH

Note : F²MC is the abbreviation of FUJITSU Flexible Microcontroller.

Be sure to refer to the "Check Sheet" for the latest cautions on development.

"Check Sheet" is seen at the following support page
URL : <http://edevice.fujitsu.com/micom/en-support/>

"Check Sheet" lists the minimal requirement items to be checked to prevent problems beforehand in system development.

MB90340E Series

■ FEATURES

• CPU

- Instruction system best suited to controller
 - Wide choice of data types (bit, byte, word, and long word)
 - Wide choice of addressing modes (23 types)
 - Enhanced functionality with signed multiply and divide instructions and the RETI instruction
 - Enhanced high-precision computing with 32-bit accumulator
- Instruction system compatible with high-level language (C language) and multitask
 - Employing system stack pointer
 - Various enhanced pointer indirect instructions
 - Barrel shift instructions
- Increased processing speed
 - 4-byte instruction queue

• Serial interface

- UART (LIN/SCI) : up to 4 channels
 - Equipped with full-duplex double buffer
 - Clock-asynchronous or clock-synchronous serial transmission is available
- I²C interface* : up to 2 channels (only for devices with a C suffix in the part number)
 - Up to 400 kbps transfer rate

• Interrupt controller

- Powerful 8-level, 34-condition interrupt feature
- Up to 16 external interrupts are supported
- Automatic data transfer function independent of CPU
 - Expanded intelligent I/O service function (EI²OS) : up to 16 channels

• I/O ports

- General-purpose input/output port (CMOS output)
 - 80 ports (for devices without an S suffix in the part number - i.e. devices that support the sub clock)
 - 82 ports (for devices with an S suffix in the part number - i.e. devices that do not support the sub clock)

• 8/10-bit A/D converter

- 16 channels (only for devices without a C suffix in the part number)
- 24 channels (only for devices with a C suffix in the part number)
- Resolution is selectable between 8-bit and 10-bit.
- Activation by external trigger input is allowed.
- Conversion time : 3 μs (at 24 MHz machine clock, including sampling time)

• Program patch function

- Detects address matches against 6 address pointers

• Timer

- Time-base timer, watch timer, watchdog timer : 1 channel
- 8/16-bit PPG timer : 8-bit × 16 channels, or 16-bit × 8 channels
- 16-bit reload timer : 4 channels
- 16-bit input/output timer
 - 16-bit free-run timer : 2 channels
(FRT0 : ICU 0/1/2/3, OCU 0/1/2/3, FRT1 : ICU 4/5/6/7, OCU 4/5/6/7)
 - 16-bit input capture: (ICU): 8 channels
 - 16-bit output compare: (OCU): 8 channels

(Continued)

(Continued)

- **Full-CAN controller**

- Up to 2 channels
- Compliant with Ver2.0A and Ver2.0B CAN specifications
- 16 built-in message buffers
- CAN wake-up function

- **Low power consumption (standby) mode**

- Sleep mode (a mode that halts CPU operating clock)
- Timebase timer mode (a mode where only the oscillation clock, sub clock, timebase timer and watch timer operate)
- Watch mode (a mode that operates sub clock and clock timer only)
- Stop mode (a mode that stops oscillation clock and sub clock)
- CPU intermittent operation mode

- **Clock modulation circuit**

- **Technology**

- CMOS technology

* : I²C license :

Purchase of Fujitsu I²C components conveys a license under the Philips I²C Patent Rights to use, these components in an I²C system provided that the system conforms to the I²C Standard Specification as defined by Philips.

MB90340E Series

■ PRODUCT LINEUP

| | | | |
|----------------------------------|---|--|--|
| Part Number | MB90V340E-101, MB90V340E-102 | MB90F342E(S), MB90F342CE(S), MB90F343E(S), MB90F343CE(S), MB90F345E(S), MB90F345CE(S), MB90F346E(S), MB90F346CE(S), MB90F347E(S), MB90F347CE(S), MB90F349E(S), MB90F349CE(S) | MB90341E(S), MB90341CE(S), MB90342E(S), MB90342CE(S), MB90346E(S), MB90346CE(S), MB90347E(S), MB90347CE(S), MB90348E(S), MB90348CE(S), MB90349E(S), MB90349CE(S) |
| Parameter | | | |
| Type | Evaluation products | Flash memory products | MASK ROM products |
| CPU | F ² MC-16LX CPU | | |
| System clock | On-chip PLL clock multiplier (×1, ×2, ×3, ×4, ×6, 1/2 when PLL stops) Minimum instruction execution time : 42 ns (4 MHz osc. PLL × 6) | | |
| ROM | External | 512 Kbytes : MB90F345E(S), MB90F345CE(S) 384 Kbytes : MB90F343E(S), MB90F343CE(S) 256 Kbytes : MB90F342E(S), MB90F342CE(S), MB90F349E(S), MB90F349CE(S) 128 Kbytes : MB90F347E(S), MB90F347CE(S) 64 Kbytes : MB90F346E(S), MB90F346CE(S) | 256 Kbytes : MB90342E(S), MB90342CE(S), MB90349E(S), MB90349CE(S) 128 Kbytes : MB90341E(S), MB90341CE(S), MB90347E(S), MB90347CE(S), MB90348E(S), MB90348CE(S) 64 Kbytes : MB90346E(S), MB90346CE(S) |
| RAM | 30 Kbytes | 20 Kbytes : MB90F343E(S), MB90F343CE(S), MB90F345E(S), MB90F345CE(S) 16 Kbytes : MB90F342E(S), MB90F342CE(S), MB90F349E(S), MB90F349CE(S) 6 Kbytes : MB90F347E(S), MB90F347CE(S) 2 Kbytes : MB90F346E(S), MB90F346CE(S) | 16 Kbytes : MB90341E(S), MB90341CE(S), MB90342E(S), MB90342CE(S), MB90348E(S), MB90348CE(S), MB90349E(S), MB90349CE(S) 6 Kbytes : MB90347E(S), MB90347CE(S) 2 Kbytes : MB90346E(S), MB90346CE(S) |
| Emulator-specific power supply*1 | Yes | — | |
| Technology | 0.35 μm CMOS with regulator for built-in power supply | 0.35 μm CMOS with built-in power supply regulator + Flash memory with Charge pump for programming voltage | |
| Operating voltage range | 5 V ± 10% | 3.5 V to 5.5 V : When normal operating (not using A/D converter) 4.0 V to 5.5 V : When using the A/D converter/Flash programming 4.5 V to 5.5 V : When using the external bus | |
| Temperature range | — | -40 °C to +105 °C | |
| Package | PGA-299 | QFP-100, LQFP-100 | |
| UART | 5 channels | 4 channels | |
| | Wide range of baud rate settings using a dedicated reload timer Special synchronous options for adapting to different synchronous serial protocols LIN functionality working either as master or slave LIN device | | |
| I ² C (400 kbps) | 2 channels | Devices with a C suffix in the part number : 2 channels Devices without a C suffix in the part number : — | |

(Continued)

MB90340E Series

| Part Number | MB90V340E-101, MB90V340E-102 | MB90F342E(S), MB90F342CE(S), MB90F343E(S), MB90F343CE(S), MB90F345E(S), MB90F345CE(S), MB90F346E(S), MB90F346CE(S), MB90F347E(S), MB90F347CE(S), MB90F349E(S), MB90F349CE(S) | MB90341E(S), MB90341CE(S), MB90342E(S), MB90342CE(S), MB90346E(S), MB90346CE(S), MB90347E(S), MB90347CE(S), MB90348E(S), MB90348CE(S), MB90349E(S), MB90349CE(S) |
|---------------------------------------|---|---|---|
| A/D Converter | 24 input channels | Devices with a C suffix in the part number : 24 channels Devices without a C suffix in the part number : 16 channels | |
| | 10-bit or 8-bit resolution Conversion time : Min 3 μ s include sample time (per one channel) | | |
| 16-bit Reload Timer (4 channels) | Operation clock frequency : $f_{sys}/2^1$, $f_{sys}/2^3$, $f_{sys}/2^5$ (f_{sys} = Machine clock frequency) Supports External Event Count function | | |
| 16-bit I/O Timer (2 channels) | Generates an interrupt signal on overflow Supports Timer Clear when the output compare finds a match Operation clock freq. : f_{sys} , $f_{sys}/2^1$, $f_{sys}/2^2$, $f_{sys}/2^3$, $f_{sys}/2^4$, $f_{sys}/2^5$, $f_{sys}/2^6$, $f_{sys}/2^7$ (f_{sys} = Machine clock freq.) I/O Timer 0 (clock input FRCK0) corresponds to ICU 0/1/2/3, OCU 0/1/2/3 I/O Timer 1 (clock input FRCK1) corresponds to ICU 4/5/6/7, OCU 4/5/6/7 | | |
| 16-bit Output Compare (8 channels) | Generates an interrupt signal when one of the 16-bit I/O timer matches the output compare register A pair of compare registers can be used to generate an output signal. | | |
| 16-bit Input Capture (8 channels) | Rising edge, falling edge or rising & falling edge sensitive Signals an interrupt upon external event | | |
| 8/16-bit Programmable Pulse Generator | 8 channels (16-bit) /16 channels (8-bit) Sixteen 8-bit reload counters Sixteen 8-bit reload registers for L pulse width Sixteen 8-bit reload registers for H pulse width | | |
| | Supports 8-bit and 16-bit operation modes A pair of 8-bit reload counters can be configured as one 16-bit reload counter or as 8-bit prescaler plus 8-bit reload counter Operating clock freq. : f_{sys} , $f_{sys}/2^1$, $f_{sys}/2^2$, $f_{sys}/2^3$, $f_{sys}/2^4$ or 128 μ s@ f_{osc} = 4 MHz (f_{sys} = Machine clock frequency, f_{osc} = Oscillation clock frequency) | | |
| CAN Interface | 3 channels | 2 channels : MB90F342E(S), MB90F342CE(S), MB90F343E(S), MB90F343CE(S), MB90F345E(S), MB90F345CE(S) 1 channel : MB90F346E(S), MB90F346CE(S), MB90F347E(S), MB90F347CE(S), MB90F349E(S), MB90F349CE(S) | 2 channels : MB90341E(S), MB90341CE(S), MB90342E(S), MB90342CE(S) 1 channel : MB90346E(S), MB90346CE(S), MB90347E(S), MB90347CE(S), MB90348E(S), MB90348CE(S), MB90349E(S), MB90349CE(S) |
| | Conforms to CAN Specification Version 2.0 Part A and B Automatic re-transmission in case of error Automatic transmission in response to Remote Frames Prioritized 16 message buffers for data and ID's Supports multiple messages Flexible configuration of acceptance filtering : Full bit compare/Full bit mask/Two partial bit masks Supports up to 1 Mbps | | |

(Continued)

MB90340E Series

(Continued)

| Part Number | MB90V340E-101, MB90V340E-102 | MB90F342E(S), MB90F342CE(S), MB90F343E(S), MB90F343CE(S), MB90F345E(S), MB90F345CE(S), MB90F346E(S), MB90F346CE(S), MB90F347E(S), MB90F347CE(S), MB90F349E(S), MB90F349CE(S) | MB90341E(S), MB90341CE(S), MB90342E(S), MB90342CE(S), MB90346E(S), MB90346CE(S), MB90347E(S), MB90347CE(S), MB90348E(S), MB90348CE(S), MB90349E(S), MB90349CE(S) |
|-------------------------------------|--|---|---|
| Parameter | | | |
| External Interrupt (16 channels) | Can be used rising edge, falling edge, starting up by H/L level input, external interrupt, expanded intelligent I/O services (EI ² OS) and DMA | | |
| D/A Converter | 2 channels | — | |
| Sub clock (maximum 100 kHz) | Only for MB90V340E-102 | Devices with sub clock : devices without an S suffix in the part number Devices without sub clock : devices with an S suffix in the part number | |
| I/O Ports | Virtually all external pins can be used as general purpose I/O port All ports are push-pull outputs Bit-wise settable as input/output or peripheral signal Can be configured 8 as CMOS schmitt trigger/ automotive inputs (in blocks of 8 pins) TTL input level settable for external bus (32-pin only for external bus) | | |
| Flash Memory | — | Supports automatic programming, Embedded Algorithm ^{TM*2} Write/Erase/Erase-Suspend/Resume commands A flag indicating completion of the algorithm Number of erase cycles : 10000 cycles Data retention time : 20 years Boot block configuration Erase can be performed on each block Block protection with external programming voltage Flash Security Feature for protecting the content of the Flash (except for MB90F346E(S) and MB90F346CE (S)) | |

*1 : It is setting of Jumper switch (TOOL VCC) when Emulator (MB2147-01) is used.
Please refer to the Emulator hardware manual for details.

*2 : Embedded Algorithm is a trade mark of Advanced Micro Devices Inc.

PIN ASSIGNMENTS

- MB90341E(S), MB90342E(S), MB90F342E(S), MB90F343E(S), MB90F345E(S), MB90346E(S), MB90F346E(S), MB90347E(S), MB90F347E(S), MB90348E(S), MB90349E(S), MB90F349E(S)

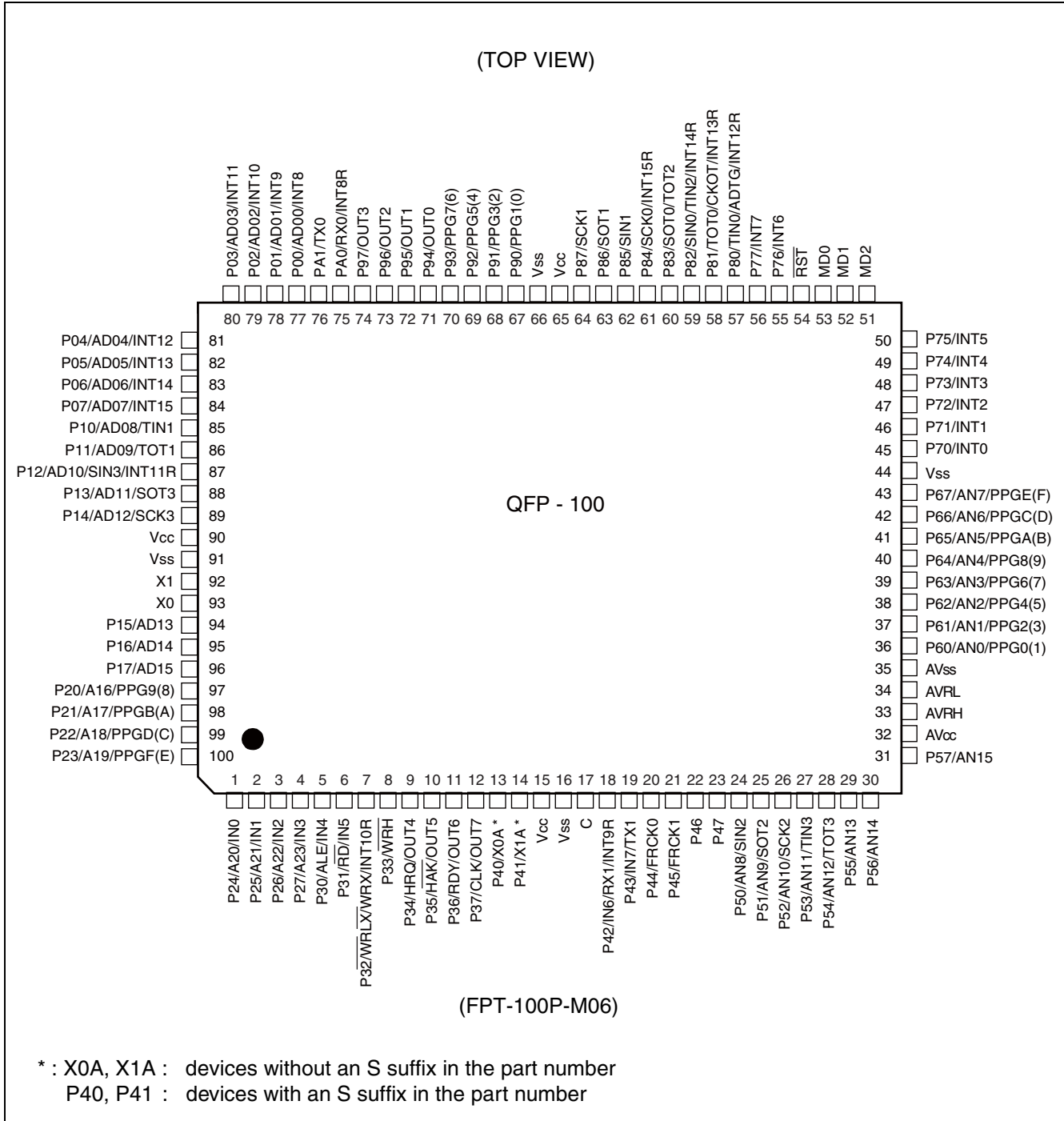

(Continued)

MB90340E Series

(Continued)

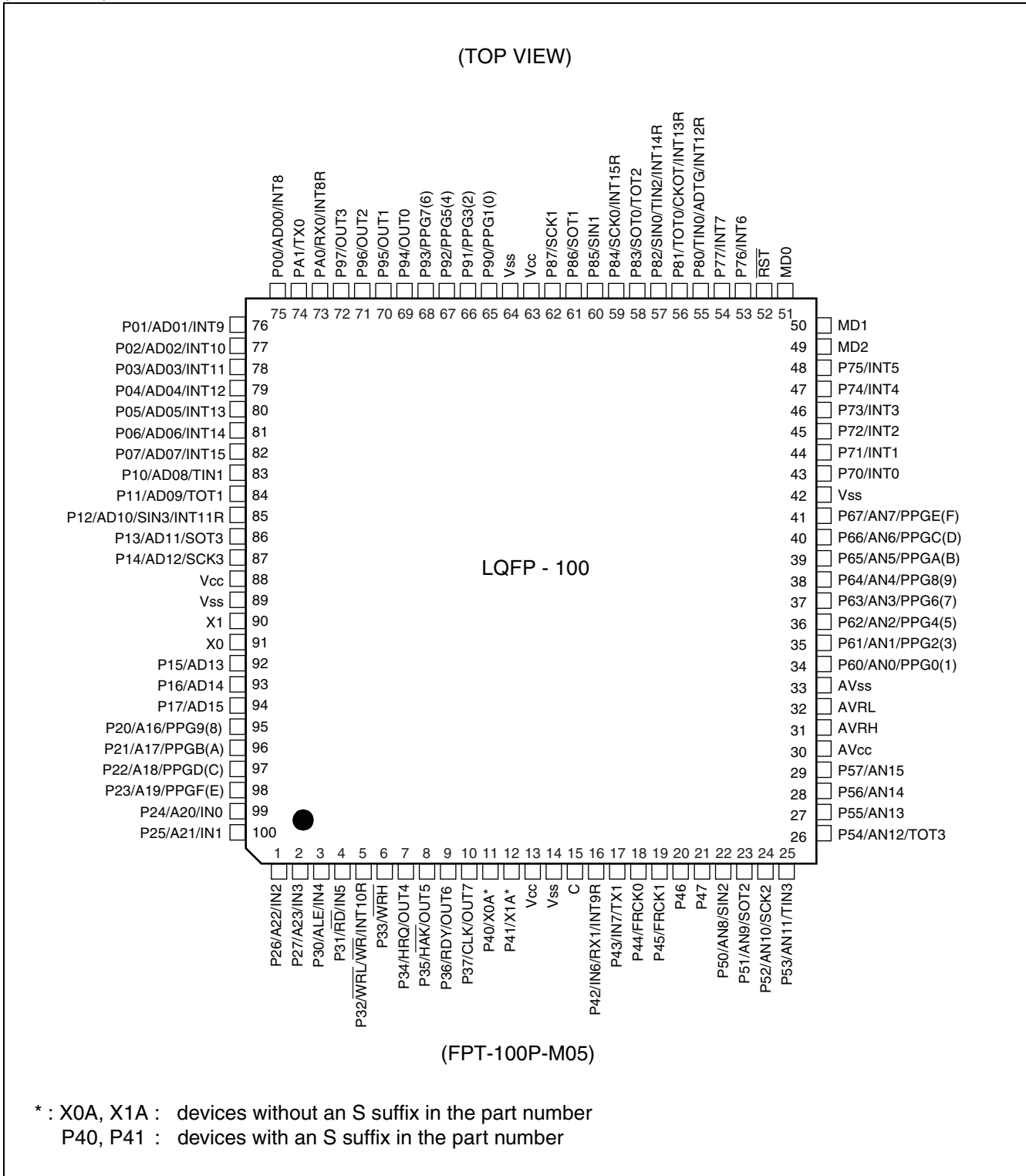

MB90340E Series

- MB90341CE(S), MB90342CE(S), MB90F342CE(S), MB90F343CE(S), MB90F345CE(S), MB90346CE(S), MB90F346CE(S), MB90347CE(S), MB90F347CE(S), MB90348CE(S), MB90349CE(S), MB90F349CE(S)

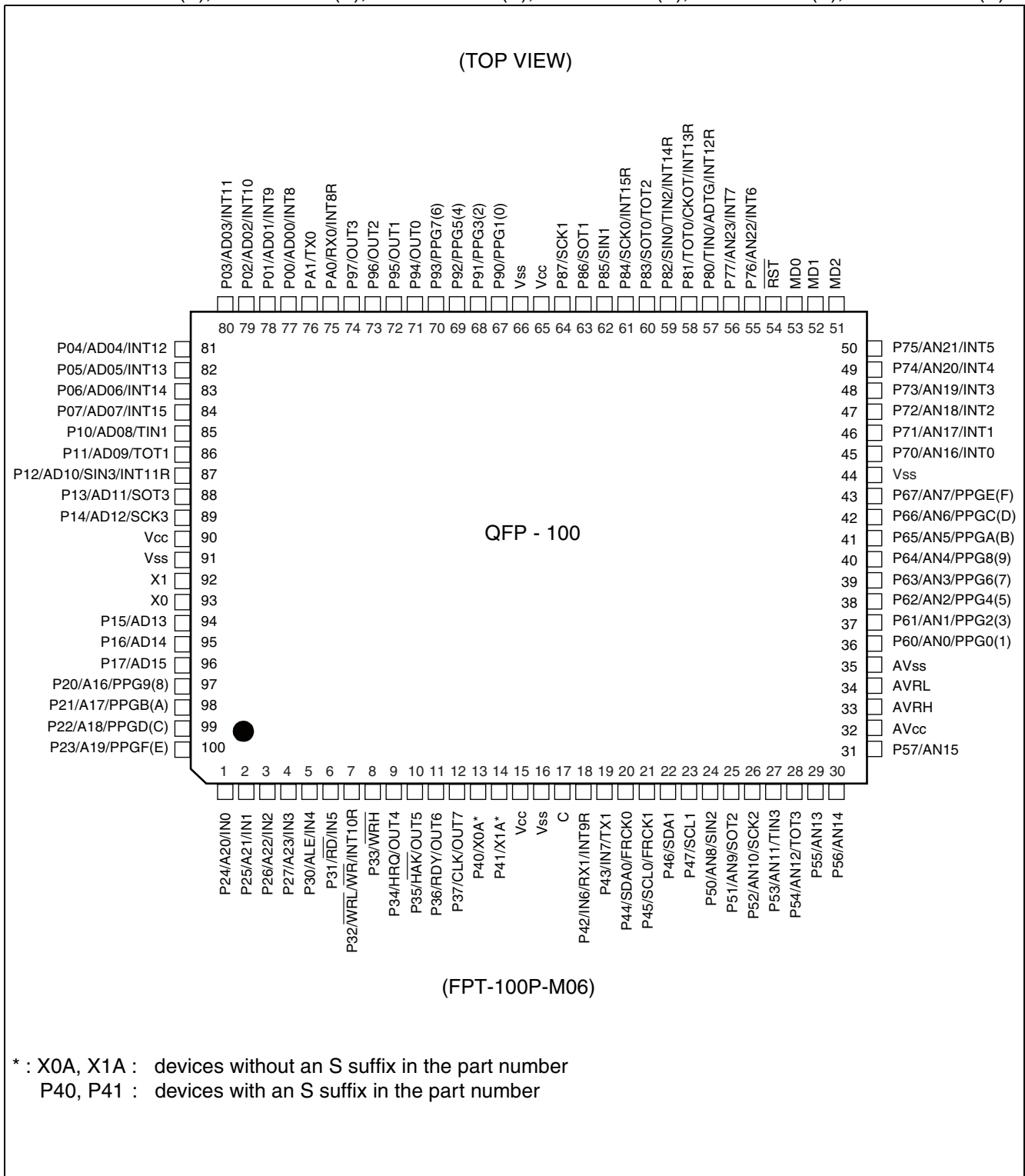

(Continued)

MB90340E Series

(Continued)

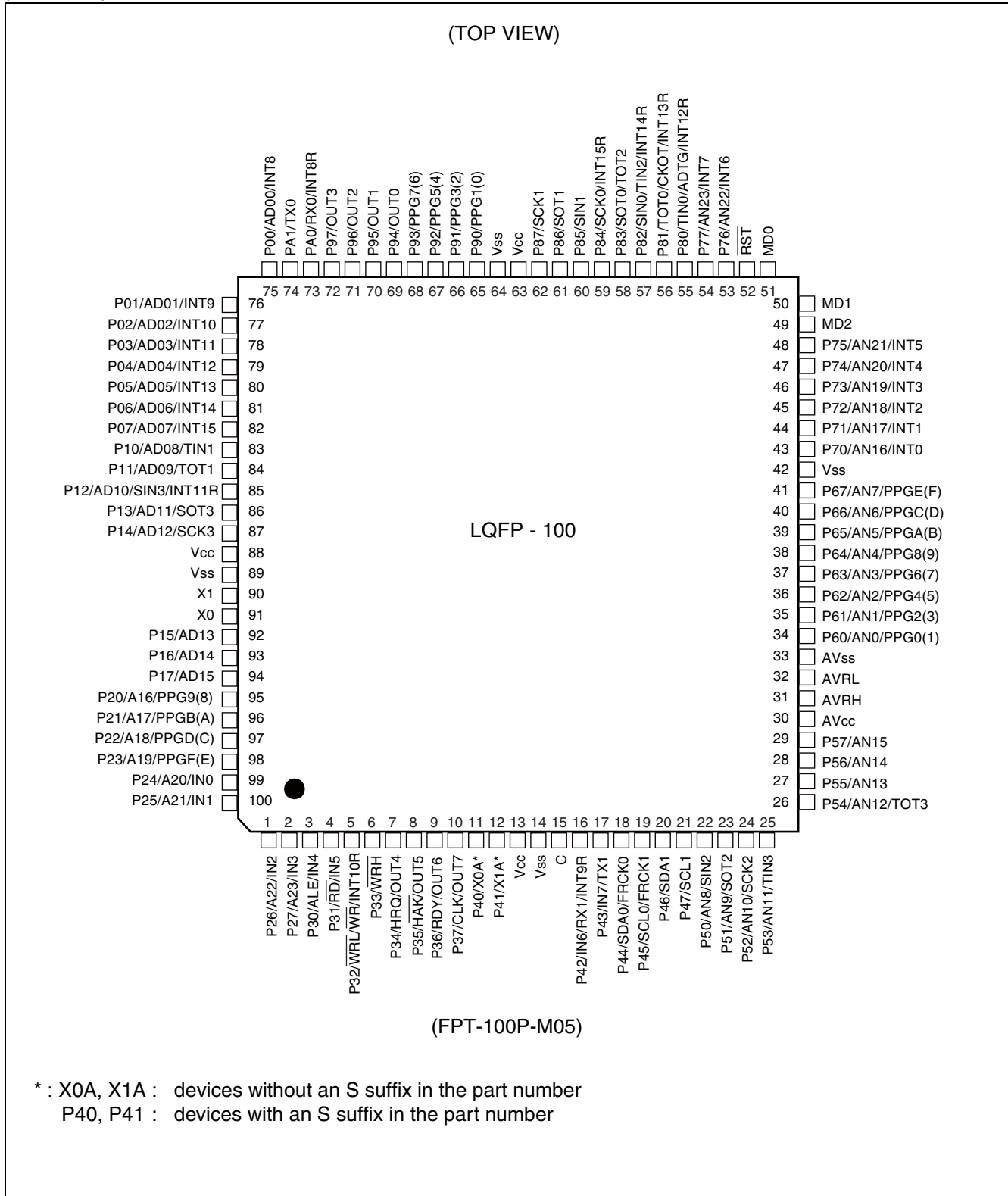

■ PIN DESCRIPTION

| Pin No. | | Pin name | I/O Circuit type*3 | Function |
|----------|-----------|----------------------------------|--------------------|--|
| QFP100*1 | LQFP100*2 | | | |
| 1 to 4 | 99 to 2 | P24 to P27 | G | General purpose I/O pins. The register can be set to select whether to use a pull-up resistor. In external bus mode, the pin is enabled as a general-purpose I/O port when the corresponding bit in the external address output control register (HACR) is 1. |
| | | A20 to A23 | | Output pins of the external address bus. When the corresponding bit in the external address output control register (HACR) is 0, the pins are enabled as high address output pins (A20 to A23). |
| | | IN0 to IN3 | | Trigger input pins for input captures. |
| 5 | 3 | P30 | G | General purpose I/O pin. The register can be set to select whether to use a pull-up resistor. This function is enabled in single-chip mode. |
| | | ALE | | Address latch enable output pin. This function is enabled when the external bus is enabled. |
| | | IN4 | | Trigger input pin for input capture. |
| 6 | 4 | P31 | G | General purpose I/O pin. The register can be set to select whether to use a pull-up resistor. This function is enabled in single-chip mode. |
| | | \overline{RD} | | External read strobe output pin. This function is enabled when the external bus is enabled. |
| | | IN5 | | Trigger input pin for input capture. |
| 7 | 5 | P32 | G | General purpose I/O pin. The register can be set to select whether to use a pull-up resistor. This function is enabled either in single-chip mode or when the $\overline{WR}/\overline{WRL}$ pin output is disabled. |
| | | $\overline{WR} / \overline{WRL}$ | | Write strobe output pin for the external data bus. This function is enabled when both the external bus and the $\overline{WR}/\overline{WRL}$ pin output are enabled. \overline{WRL} is used to write-strobe 8 lower bits of the data bus in 16-bit access while \overline{WR} is used to write-strobe 8 bits of the data bus in 8-bit access. |
| | | INT10R | | External interrupt request input pin. |
| 8 | 6 | P33 | G | General purpose I/O pin. The register can be set to select whether to use a pull-up resistor. This function is enabled either in single-chip mode or when the \overline{WRH} pin output is disabled. |
| | | \overline{WRH} | | Write strobe output pin for the upper 8 bits of the external data bus. This function is enabled when the external bus is enabled, when the external bus 16-bit mode is selected, and when the \overline{WRH} output pin is enabled. |

(Continued)

MB90340E Series

| Pin No. | | Pin name | I/O Circuit type*3 | Function |
|----------|-----------|-------------------------|--------------------------|--|
| QFP100*1 | LQFP100*2 | | | |
| 9 | 7 | P34 | G | General purpose I/O pin. The register can be set to select whether to use a pull-up resistor. This function is enabled either in single-chip mode or when the hold function is disabled. |
| | | HRQ | | Hold request input pin. This function is enabled when both the external bus and the hold function are enabled. |
| | | OUT4 | | Waveform output pin for output compare. |
| 10 | 8 | P35 | G | General purpose I/O pin. The register can be set to select whether to use a pull-up resistor. This function is enabled either in single-chip mode or when the hold function is disabled. |
| | | $\overline{\text{HAK}}$ | | Hold acknowledge output pin. This function is enabled when both the external bus and the hold function are enabled. |
| | | OUT5 | | Waveform output pin for output compare. |
| 11 | 9 | P36 | G | General purpose I/O pin. The register can be set to select whether to use a pull-up resistor. This function is enabled either in single-chip mode or when the external ready function is disabled. |
| | | RDY | | External ready input pin. This function is enabled when both the external bus and the external ready function are enabled. |
| | | OUT6 | | Waveform output pin for output compare. |
| 12 | 10 | P37 | G | General purpose I/O pin. The register can be set to select whether to use a pull-up resistor. This function is enabled either in single-chip mode or when the clock output is disabled. |
| | | CLK | | Clock output pin. This function is enabled when both the external bus and clock output are enabled. |
| | | OUT7 | | Waveform output pin for output compare OCU7 |
| 13, 14 | 11, 12 | P40, P41 | F | General purpose I/O pins. (devices with an S suffix in the part number and or MB90V340E-101) |
| | | X0A, X1A | B | Oscillation pins for sub clock (devices without an S suffix in the part number and or MB90V340E-102) |
| 15 | 13 | V _{CC} | — | Power (3.5 V to 5.5 V) input pin |
| 16 | 14 | V _{SS} | — | GND pin |
| 17 | 15 | C | K | This is the power supply stabilization capacitor This pin should be connected to a ceramic capacitor with a capacitance greater than or equal to 0.1 μF . |
| 18 | 16 | P42 | F | General purpose I/O pin. |
| | | IN6 | | Trigger input pin for input capture. |
| | | RX1 | | RX input pin for CAN1 Interface (MB90341E/342E/F342E/F343E/F345E only) |
| | | INT9R | | External interrupt request input pin |

(Continued)

MB90340E Series

| Pin No. | | Pin name | I/O Circuit type*3 | Function |
|----------|-----------|------------------|--------------------------|--|
| QFP100*1 | LQFP100*2 | | | |
| 19 | 17 | P43 | F | General purpose I/O pin. |
| | | IN7 | | Trigger input pin for input capture. |
| | | TX1 | | TX Output pin for CAN1 (MB90341E/342E/F342E/F343E/F345E only) |
| 20 | 18 | P44 | H | General purpose I/O pin. |
| | | SDA0 | | Serial data I/O pin for I ² C (devices with a C suffix in the part number) |
| | | FRCK0 | | Input pin for the 16-bit I/O Timer 0 |
| 21 | 19 | P45 | H | General purpose I/O pin. |
| | | SCL0 | | Serial clock I/O pin for I ² C (devices with a C suffix in the part number) |
| | | FRCK1 | | Input pin for the 16-bit I/O Timer |
| 22 | 20 | P46 | H | General purpose I/O pin. |
| | | SDA1 | | Serial data I/O pin for I ² C (devices with a C suffix in the part number) |
| 23 | 21 | P47 | H | General purpose I/O pin. |
| | | SCL1 | | Serial clock I/O pin for I ² C (devices with a C suffix in the part number) |
| 24 | 22 | P50 | O | General purpose I/O pin. |
| | | AN8 | | Analog input pin for the A/D converter |
| | | SIN2 | | Serial data input pin for UART2 |
| 25 | 23 | P51 | I | General purpose I/O pin. |
| | | AN9 | | Analog input pin for the A/D converter |
| | | SOT2 | | Serial data output pin for UART2 |
| 26 | 24 | P52 | I | General purpose I/O pin. |
| | | AN10 | | Analog input pin for the A/D converter |
| | | SCK2 | | Clock I/O pin for UART2 |
| 27 | 25 | P53 | I | General purpose I/O pin. |
| | | AN11 | | Analog input pin for the A/D converter |
| | | TIN3 | | Event input pin for the reload timer |
| 28 | 26 | P54 | I | General purpose I/O pin. |
| | | AN12 | | Analog input pin for the A/D converter |
| | | TOT3 | | Output pin for the reload timer |
| 29 | 27 | P55 | I | General purpose I/O pin. |
| | | AN13 | | Analog input pin for the A/D converter |
| 30, 31 | 28, 29 | P56, P57 | J | General purpose I/O pins. |
| | | AN14, AN15 | | Analog input pins for the A/D converter |
| 32 | 30 | AV _{cc} | K | Analog power input pin for the A/D Converter |

(Continued)

MB90340E Series

| Pin No. | | Pin name | I/O Circuit type*3 | Function |
|----------|-----------|---------------------------|--------------------|---|
| QFP100*1 | LQFP100*2 | | | |
| 33 | 31 | AVRH | L | Reference voltage input pin for the A/D Converter. This power supply must be turned on or off while a voltage higher than or equal to AVRH is applied to AV _{CC} . |
| 34 | 32 | AVRL | K | Lower reference voltage input pin for the A/D Converter |
| 35 | 33 | AV _{SS} | K | Analog GND pin for the A/D Converter |
| 36 to 43 | 34 to 41 | P60 to P67 | I | General purpose I/O pins. |
| | | AN0 to AN7 | | Analog input pins for the A/D converter |
| | | PPG0, 2, 4, 6, 8, A, C, E | | Output pins for PPGs |
| 44 | 42 | V _{SS} | — | GND pin |
| 45 to 50 | 43 to 48 | P70 to P75 | I | General purpose I/O pins. |
| | | AN16 to AN21 | | Analog input pins for the A/D converter (devices with a C suffix in the part number) |
| | | INT0 to INT5 | | External interrupt request input pins |
| 51 | 49 | MD2 | D | Input pin for specifying the operating mode. |
| 52, 53 | 50, 51 | MD1, MD0 | C | Input pins for specifying the operating mode. |
| 54 | 52 | $\overline{\text{RST}}$ | E | Reset input pin |
| 55, 56 | 53, 54 | P76, P77 | I | General purpose I/O pins. |
| | | AN22, AN23 | | Analog input pins for the A/D converter (devices with a C suffix in the part number) |
| | | INT6, INT7 | | External interrupt request input pins |
| 57 | 55 | P80 | F | General purpose I/O pin. |
| | | TIN0 | | Event input pin for the reload timer |
| | | ADTG | | Trigger input pin for the A/D converter |
| | | INT12R | | External interrupt request input pin |
| 58 | 56 | P81 | F | General purpose I/O pin. |
| | | TOT0 | | Output pin for the reload timer |
| | | CKOT | | Output pin for the clock monitor |
| | | INT13R | | External interrupt request input pin |
| 59 | 57 | P82 | M | General purpose I/O pin. |
| | | SIN0 | | Serial data input pin for UART0 |
| | | TIN2 | | Event input pin for the reload timer |
| | | INT14R | | External interrupt request input pin |
| 60 | 58 | P83 | F | General purpose I/O pin. |
| | | SOT0 | | Serial data output pin for UART0 |
| | | TOT2 | | Output pin for the reload timer |

(Continued)

MB90340E Series

| Pin No. | | Pin name | I/O Circuit type*3 | Function |
|----------|-----------|-----------------|--------------------|--|
| QFP100*1 | LQFP100*2 | | | |
| 61 | 59 | P84 | F | General purpose I/O pin. |
| | | SCK0 | | Clock I/O pin for UART0 |
| | | INT15R | | External interrupt request input pin |
| 62 | 60 | P85 | M | General purpose I/O pin. |
| | | SIN1 | | Serial data input pin for UART1 |
| 63 | 61 | P86 | F | General purpose I/O pin. |
| | | SOT1 | | Serial data output pin for UART1 |
| 64 | 62 | P87 | F | General purpose I/O pin. |
| | | SCK1 | | Clock I/O pin for UART1 |
| 65 | 63 | V _{CC} | — | Power (3.5 V to 5.5 V) input pin |
| 66 | 64 | V _{SS} | — | GND pin |
| 67 to 70 | 65 to 68 | P90 to P93 | F | General purpose I/O pins |
| | | PPG1, 3, 5, 7 | | Output pins for PPGs |
| 71 to 74 | 69 to 72 | P94 to P97 | F | General purpose I/O pins |
| | | OUT0 to OUT3 | | Waveform output pins for output compares. This function is enabled when the OCU enables waveform output. |
| 75 | 73 | PA0 | F | General purpose I/O pin. |
| | | RX0 | | RX input pin for CAN0 Interface |
| | | INT8R | | External interrupt request input pin |
| 76 | 74 | PA1 | F | General purpose I/O pin. |
| | | TX0 | | TX Output pin for CAN0 |
| 77 to 84 | 75 to 82 | P00 to P07 | G | General purpose I/O pins. The register can be set to select whether to use a pull-up resistor. This function is enabled in single-chip mode. |
| | | AD00 to AD07 | | I/O pins for 8 lower bits of the external address/data bus. This function is enabled when the external bus is enabled. |
| | | INT8 to INT15 | | External interrupt request input pins. |
| 85 | 83 | P10 | G | General purpose I/O pin. The register can be set to select whether to use a pull-up resistor. This function is enabled in single-chip mode. |
| | | AD08 | | I/O pin for the external address/data bus. This function is enabled when the external bus is enabled. |
| | | TIN1 | | Event input pin for the reload timer |

(Continued)

MB90340E Series

| Pin No. | | Pin name | I/O Circuit type*3 | Function |
|----------|-----------|-----------------|--------------------|---|
| QFP100*1 | LQFP100*2 | | | |
| 86 | 84 | P11 | G | General purpose I/O pin. The register can be set to select whether to use a pull-up resistor. This function is enabled in single-chip mode. |
| | | AD09 | | I/O pin for the external address/data bus. This function is enabled when the external bus is enabled. |
| | | TOT1 | | Output pin for the reload timer |
| 87 | 85 | P12 | N | General purpose I/O pin. The register can be set to select whether to use a pull-up resistor. This function is enabled in single-chip mode. |
| | | AD10 | | I/O pin for the external address/data bus. This function is enabled when the external bus is enabled. |
| | | SIN3 | | Serial data input pin for UART3 |
| | | INT11R | | External interrupt request input pin |
| 88 | 86 | P13 | G | General purpose I/O pin. The register can be set to select whether to use a pull-up resistor. This function is enabled in single-chip mode. |
| | | AD11 | | I/O pin for the external address/data bus. This function is enabled when the external bus is enabled. |
| | | SOT3 | | Serial data output pin for UART3 |
| 89 | 87 | P14 | G | General purpose I/O pin. The register can be set to select whether to use a pull-up resistor. This function is enabled in single-chip mode. |
| | | AD12 | | I/O pin for the external address/data bus. This function is enabled when the external bus is enabled. |
| | | SCK3 | | Clock I/O pin for UART3 |
| 90 | 88 | V _{CC} | — | Power (3.5 V to 5.5 V) input pin |
| 91 | 89 | V _{SS} | — | GND pin |
| 92 | 90 | X1 | A | Main clock output pin |
| 93 | 91 | X0 | | Main clock input pin |
| 94 | 92 | P15 | G | General purpose I/O pin. The register can be set to select whether to use a pull-up resistor. This function is enabled in single-chip mode. |
| | | AD13 | | I/O pin for the external address/data bus. This function is enabled when the external bus is enabled. |
| 95 | 93 | P16 | G | General purpose I/O pin. The register can be set to select whether to use a pull-up resistor. This function is enabled in single-chip mode. |
| | | AD14 | | I/O pin for the external address/data bus. This function is enabled when the external bus is enabled. |

(Continued)

MB90340E Series

(Continued)

| Pin No. | | Pin name | I/O Circuit type*3 | Function |
|-----------|-----------|-------------------------|--------------------|---|
| QFP100*1 | LQFP100*2 | | | |
| 96 | 94 | P17 | G | General purpose I/O pin. The register can be set to select whether to use a pull-up resistor. This function is enabled in single-chip mode. |
| | | AD15 | | I/O pin for the external address/data bus. This function is enabled when the external bus is enabled. |
| 97 to 100 | 95 to 98 | P20 to P23 | G | General purpose I/O pins. The register can be set to select whether to use a pull-up resistor. In external bus mode, the pin is enabled as a general-purpose I/O port when the corresponding bit in the external address output control register (HACR) is 1. |
| | | A16 to A19 | | Output pins of the external address bus. When the corresponding bit in the external address output control register (HACR) is 0, the pins are enabled as high address output pins (A16 to A19). |
| | | PPG9,PPGB, PPGD,PPGF | | Output pins for PPGs |

*1 : FPT-100P-M06

*2 : FPT-100P-M05

*3 : For I/O circuit type, refer to “■ I/O CIRCUIT TYPE”.

MB90340E Series

■ I/O CIRCUIT TYPE

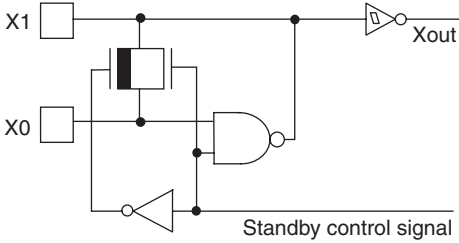
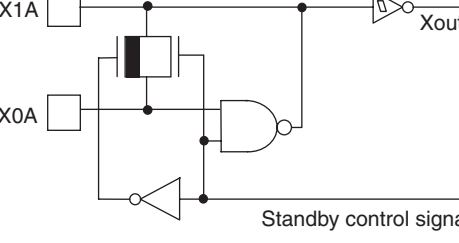
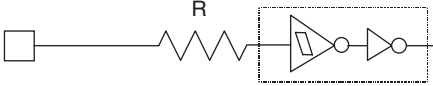
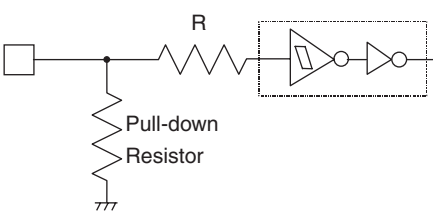
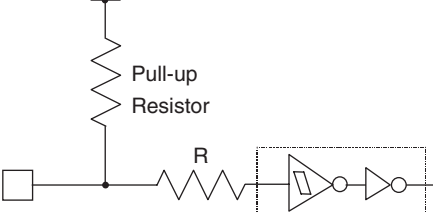
| Type | Circuit | Remarks |
|------|---|--|
| A |  | <p>Oscillation circuit High-speed oscillation feedback resistor = approx. 1 MΩ</p> |
| B |  | <p>Oscillation circuit Low-speed oscillation feedback resistor = approx. 10 MΩ</p> |
| C |  | <ul style="list-style-type: none"> • MASK ROM and evaluation products: CMOS hysteresis input pin • Flash memory products: CMOS input pin |
| D |  | <p>MASK ROM and evaluation products:</p> <ul style="list-style-type: none"> • CMOS hysteresis input pin • Pull-down resistor value: approx. 50 kΩ <p>Flash memory products:</p> <ul style="list-style-type: none"> • CMOS input pin • No pull-down |
| E |  | <p>CMOS hysteresis input pin Pull-up resistor value: approx. 50 kΩ</p> |

(Continued)

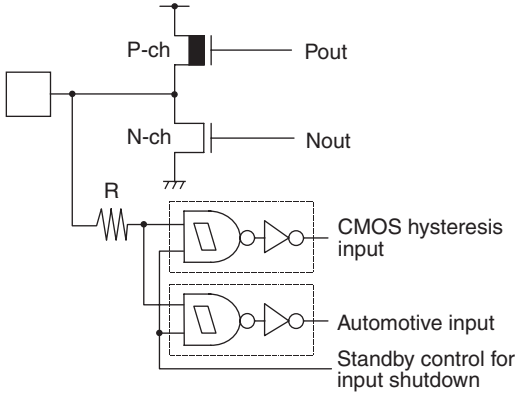
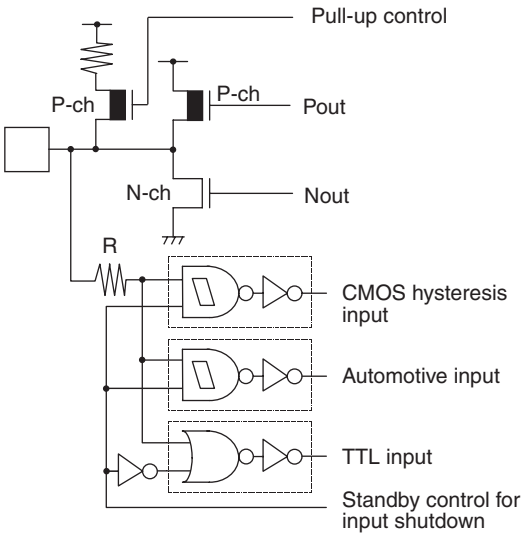
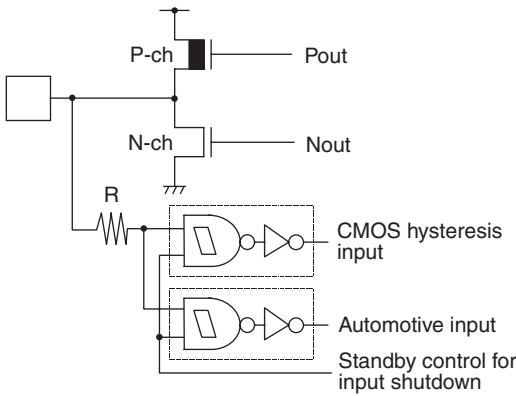
| Type | Circuit | Remarks |
|------|---|--|
| F |  <p>The diagram for Type F shows a CMOS output stage with a P-channel MOSFET (P-ch) and an N-channel MOSFET (N-ch). The P-ch MOSFET is connected to the output terminal Pout, and the N-ch MOSFET is connected to the output terminal Nout. A pull-up resistor R is connected between the input and the P-ch MOSFET gate. The input is also connected to three logic blocks: a CMOS hysteresis input (represented by a NAND gate with a feedback loop), an Automotive input (represented by a NAND gate), and a Standby control for input shutdown (represented by a NAND gate).</p> | <ul style="list-style-type: none"> • CMOS level output ($I_{OL} = 4 \text{ mA}$, $I_{OH} = -4 \text{ mA}$) • CMOS hysteresis input (with function to disconnect input during standby) • Automotive input (with function to disconnect input during standby) |
| G |  <p>The diagram for Type G shows a CMOS output stage with a P-channel MOSFET (P-ch) and an N-channel MOSFET (N-ch). The P-ch MOSFET is connected to the output terminal Pout, and the N-ch MOSFET is connected to the output terminal Nout. A pull-up resistor R is connected between the input and the P-ch MOSFET gate. A pull-up control resistor is connected between the input and the P-ch MOSFET source. The input is also connected to four logic blocks: a CMOS hysteresis input (represented by a NAND gate with a feedback loop), an Automotive input (represented by a NAND gate), a TTL input (represented by an AND gate), and a Standby control for input shutdown (represented by a NAND gate).</p> | <ul style="list-style-type: none"> • CMOS level output ($I_{OL} = 4 \text{ mA}$, $I_{OH} = -4 \text{ mA}$) • CMOS hysteresis input (with function to disconnect input during standby) • Automotive input (with function to disconnect input during standby) • TTL input (with function to disconnect input during standby) • Programmable pull-up resistor: $50 \text{ k}\Omega$ approx. |
| H |  <p>The diagram for Type H shows a CMOS output stage with a P-channel MOSFET (P-ch) and an N-channel MOSFET (N-ch). The P-ch MOSFET is connected to the output terminal Pout, and the N-ch MOSFET is connected to the output terminal Nout. A pull-up resistor R is connected between the input and the P-ch MOSFET gate. The input is also connected to three logic blocks: a CMOS hysteresis input (represented by a NAND gate with a feedback loop), an Automotive input (represented by a NAND gate), and a Standby control for input shutdown (represented by a NAND gate).</p> | <ul style="list-style-type: none"> • CMOS level output ($I_{OL} = 3 \text{ mA}$, $I_{OH} = -3 \text{ mA}$) • CMOS hysteresis input (with function to disconnect input during standby) • Automotive input (with function to disconnect input during standby) |

(Continued)

MB90340E Series

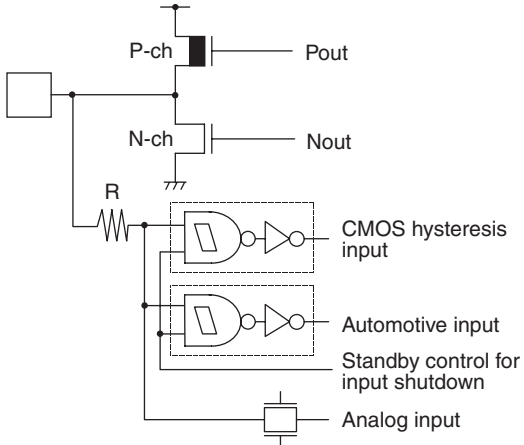
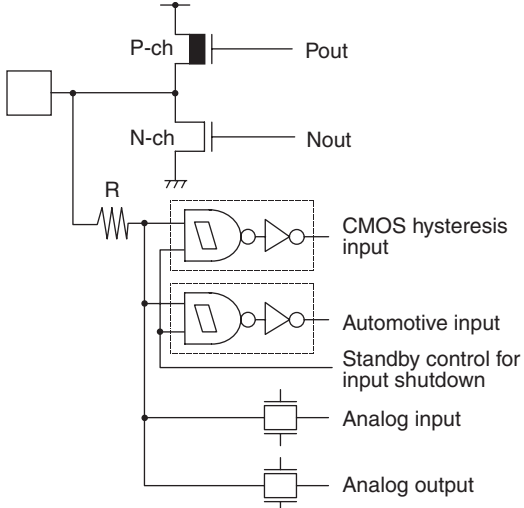
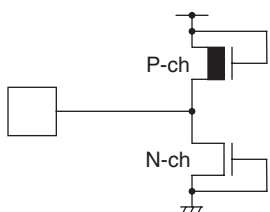
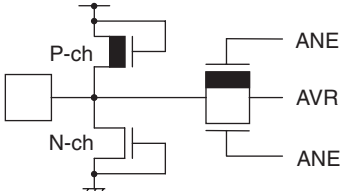
| Type | Circuit | Remarks |
|------|---|---|
| I |  | <ul style="list-style-type: none"> • CMOS level output ($I_{OL} = 4 \text{ mA}$, $I_{OH} = -4 \text{ mA}$) • CMOS hysteresis input (with function to disconnect input during standby) • Automotive input (with function to disconnect input during standby) • A/D converter analog input |
| J |  | <ul style="list-style-type: none"> • CMOS level output ($I_{OL} = 4 \text{ mA}$, $I_{OH} = -4 \text{ mA}$) • D/A analog output • CMOS hysteresis input (with function to disconnect input during standby) • Automotive input (with function to disconnect input during standby) • A/D converter analog input |
| K |  | <p>Power supply input protection circuit</p> |
| L |  | <ul style="list-style-type: none"> • A/D converter reference voltage power supply input pin, with the protection circuit • Flash memory devices do not have a protection circuit against V_{CC} for pin AVRH |

(Continued)

(Continued)

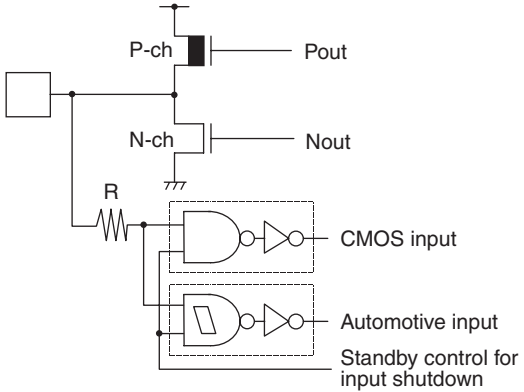
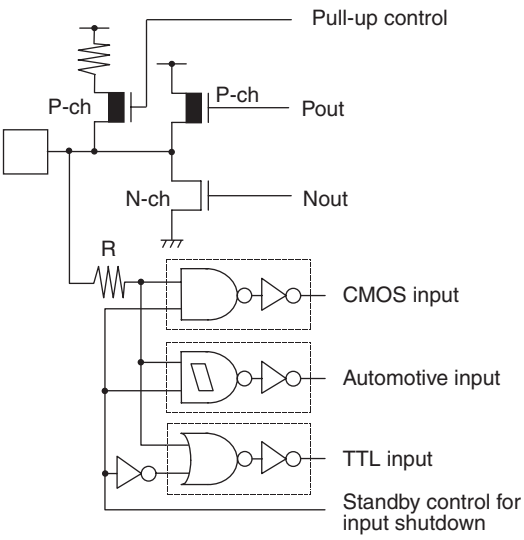
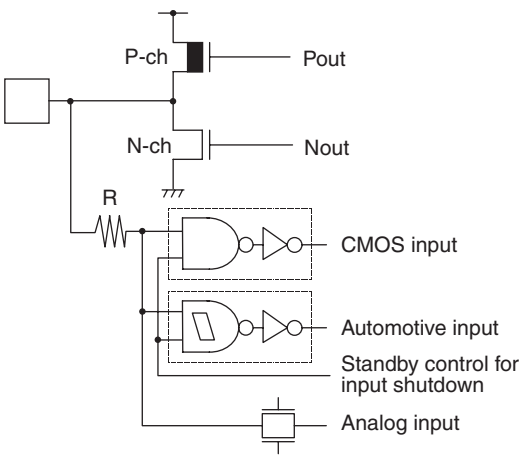
| Type | Circuit | Remarks |
|------|---|--|
| M |  | <ul style="list-style-type: none"> • CMOS level output ($I_{OL} = 4 \text{ mA}$, $I_{OH} = -4 \text{ mA}$) • CMOS input (with function to disconnect input during standby) • Automotive input (with function to disconnect input during standby) |
| N |  | <ul style="list-style-type: none"> • CMOS level output ($I_{OL} = 4 \text{ mA}$, $I_{OH} = -4 \text{ mA}$) • CMOS input (with function to disconnect input during standby) • Automotive input (with function to disconnect input during standby) • TTL input (with function to disconnect input during standby) <p>Programmable pull-up resistor: 50 kΩ approx</p> |
| O |  | <ul style="list-style-type: none"> • CMOS level output ($I_{OL} = 4 \text{ mA}$, $I_{OH} = -4 \text{ mA}$) • CMOS input (with function to disconnect input during standby) • Automotive input (with function to disconnect input during standby) • A/D converter analog input |

MB90340E Series

■ HANDLING DEVICES

1. Preventing latch-up

CMOS IC may suffer latch-up under the following conditions:

- A voltage higher than V_{CC} or lower than V_{SS} is applied to an input or output pin.
- A voltage higher than the rated voltage is applied between V_{CC} and V_{SS} pins.
- The AV_{CC} power supply is applied before the V_{CC} voltage.

Latch-up may increase the power supply current drastically, causing thermal damage to the device.

For the same reason, also be careful not to let the analog power-supply voltage (AV_{CC} , AV_{RH}) exceed the digital power-supply voltage.

2. Handling unused pins

Leaving unused input terminals open may lead to permanent damage due to malfunction and latch-up; pull up or pull down the terminals through the resistors of 2 k Ω or more.

3. Power supply pins (V_{CC}/V_{SS})

- If there are multiple V_{CC} and V_{SS} pins, from the point of view of device design, pins to be of the same potential are connected inside of the device to prevent malfunction such as latch-up.

To reduce unnecessary radiation, prevent malfunctioning of the strobe signal due to the rise of ground level, and observe the standard for total output current, be sure to connect the V_{CC} and V_{SS} pins to the power supply and ground externally.

Connect V_{CC} and V_{SS} pins to the device from the current supply source at a possibly low impedance.

- As a measure against power supply noise, it is recommended to connect a capacitor of about 0.1 μF as a bypass capacitor between V_{CC} and V_{SS} pins in the vicinity of V_{CC} and V_{SS} pins of the device.

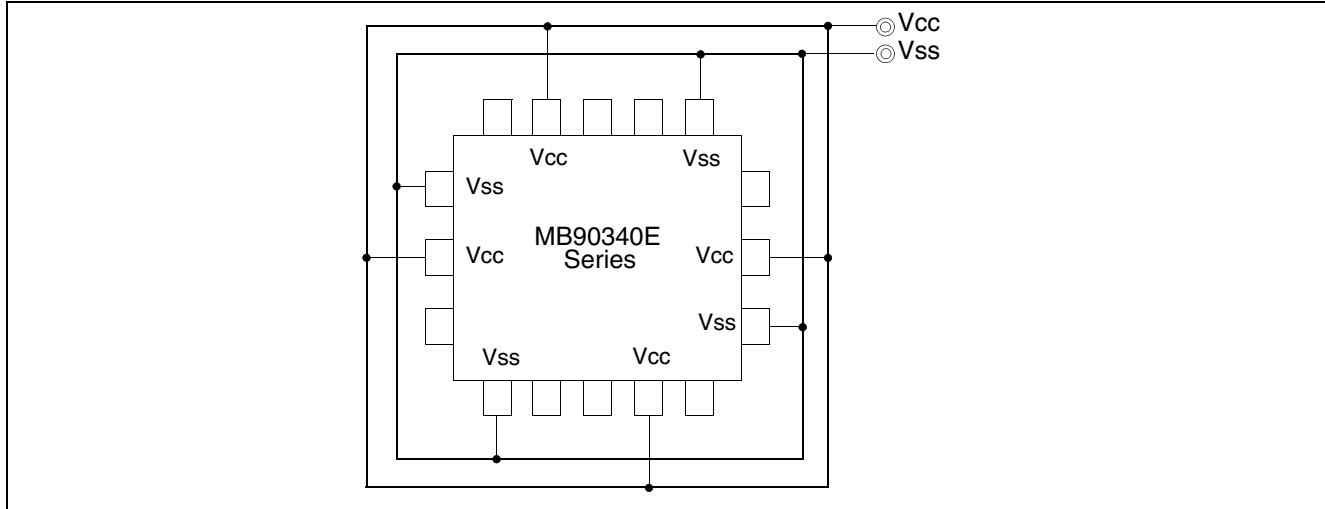

4. Mode Pins (MD0 to MD2)

Connect the mode pins directly to V_{CC} or V_{SS} pins. To prevent the device unintentionally entering test mode due to noise, lay out the printed circuit board so as to minimize the distance from the mode pins to V_{CC} or V_{SS} pins and to provide a low-impedance connection.

5. Sequence for Turning On the Power Supply to the A/D Converter and Analog Inputs

Make sure to turn on the A/D converter power supply (AV_{CC} , AV_{RH} , AV_{RL}) and analog inputs (AN0 to AN23) after turning-on the digital power supply (V_{CC}).

Turn-off the digital power after turning off the A/D converter supply and analog inputs. In this case, make sure that the voltage does not exceed AV_{RH} or AV_{CC} (turning on/off the analog and digital power supplies simultaneously is acceptable).

6. Connection of Unused A/D Converter Pins when the A/D Converter is Used

Connect unused pins of A/D converter to $AV_{CC} = V_{CC}$, $AV_{SS} = AV_{RH} = AV_{RL} = V_{SS}$.

7. Crystal Oscillator Circuit

The X0, X1 pins and X0A, X1A pins may be possible causes of abnormal operation. Make sure to provide bypass capacitors via the shortest distance from X0, X1 pins and X0A, X1A pins, crystal oscillator (or ceramic oscillator) and ground lines, and make sure, to the utmost effort, that the oscillation circuit lines do not cross the lines of other circuits. It is highly recommended to provide a printed circuit board art work surrounding X0, X1 pins and X0A, X1A pins with a ground area for stabilizing the operation.

For each of the mass-production products, request an oscillator evaluation from the manufacturer of the oscillator you are using.

8. Pull-up/down resistors

The MB90340E Series does not support internal pull-up/down resistors (except for the pull-up resistors built into ports 0 to 3). Use external components where needed.

9. Using external clock

To use an external clock, drive the X0 pin and leave the X1 pin open.

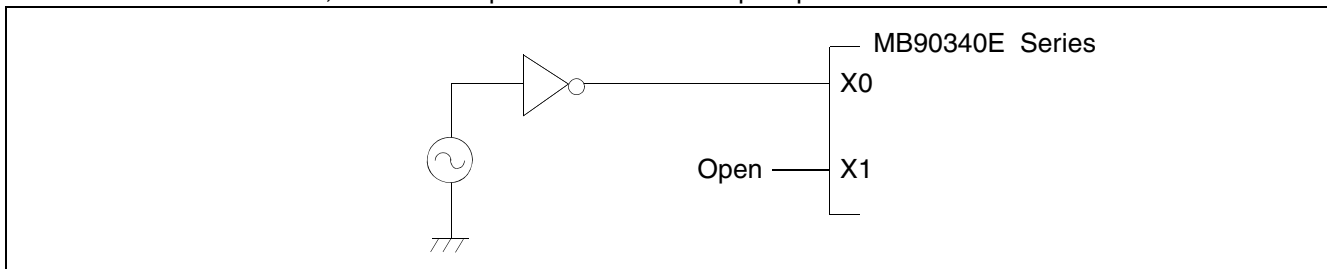

10. Precautions when not using a sub clock signal

If you do not connect pins X0A and X1A to an oscillator, use pull-down handling on the X0A pin, and leave the X1A pin open.

11. Notes on operation in PLL clock mode

If PLL clock mode is selected, the microcontroller attempt to be working with the self-oscillating circuit even when there is no external oscillator or the external clock input is stopped. Performance of this operation, however, cannot be guaranteed.

12. Notes on Power-On

To prevent the internal regulator circuit from malfunctioning, set the voltage rise time during power-on to 50 μ s or more (0.2 V to 2.7 V)

MB90340E Series

13. Stabilization of power supply voltage

A sudden change in the supply voltage may cause the device to malfunction even within the V_{CC} supply voltage operating range. Therefore, the V_{CC} supply voltage should be stabilized. For reference, the supply voltage should be controlled so that V_{CC} ripple variations (peak- to-peak values) at commercial frequencies (50 MHz/60 MHz) fall below 10% of the standard V_{CC} supply voltage and the coefficient of fluctuation does not exceed 0.1 V/ms at instantaneous power switching.

14. Port 0 to Port 3 Output During Power-on (External-bus Mode)

As shown below, when the power is turned on in External-Bus mode, there is a possibility that output signal of Port 0 to Port 3 might be unstable irrespective of the reset input.

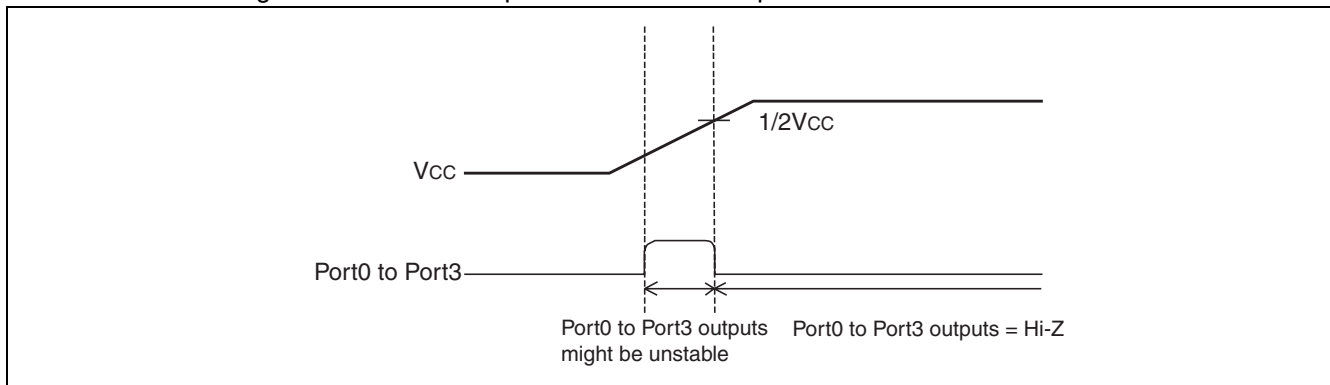

15. Notes on Using the CAN Function

To use the CAN function, please set the DIRECT bit of the CAN Direct Mode Register (CDMR) to 1.

16. Flash Security Function (except for MB90F346E)

A security bit is located in the area of the flash memory.

If protection code 01_H is written in the security bit, the flash memory is in the protected state by security.

Therefore please do not write 01_H in this address if you do not use the security function.

Refer to following table for the address of the security bit.

| | Flash memory size | Address of the security bit |
|------------------------|-------------------------------|-----------------------------|
| MB90F347E | Embedded 1 Mbit Flash Memory | FE0001 _H |
| MB90F342E MB90F349E | Embedded 2 Mbits Flash Memory | FC0001 _H |
| MB90F343E | Embedded 3 Mbits Flash Memory | F90001 _H |
| MB90F345E | Embedded 4 Mbits Flash Memory | F80001 _H |

■ BLOCK DIAGRAMS

MB90341E(S), MB90341CE(S), MB90342E(S), MB90342CE(S), MB90F342E(S), MB90F342CE(S), MB90F343E(S), MB90F343CE(S), MB90F345E(S), MB90F345CE(S), MB90346E(S), MB90346CE(S), MB90F346E(S), MB90F346CE(S), MB90347E(S), MB90347CE(S), MB90F347E(S), MB90F347CE(S), MB90348E(S), MB90348CE(S), MB90349E(S), MB90349CE(S), MB90F349E(S), MB90F349CE(S)

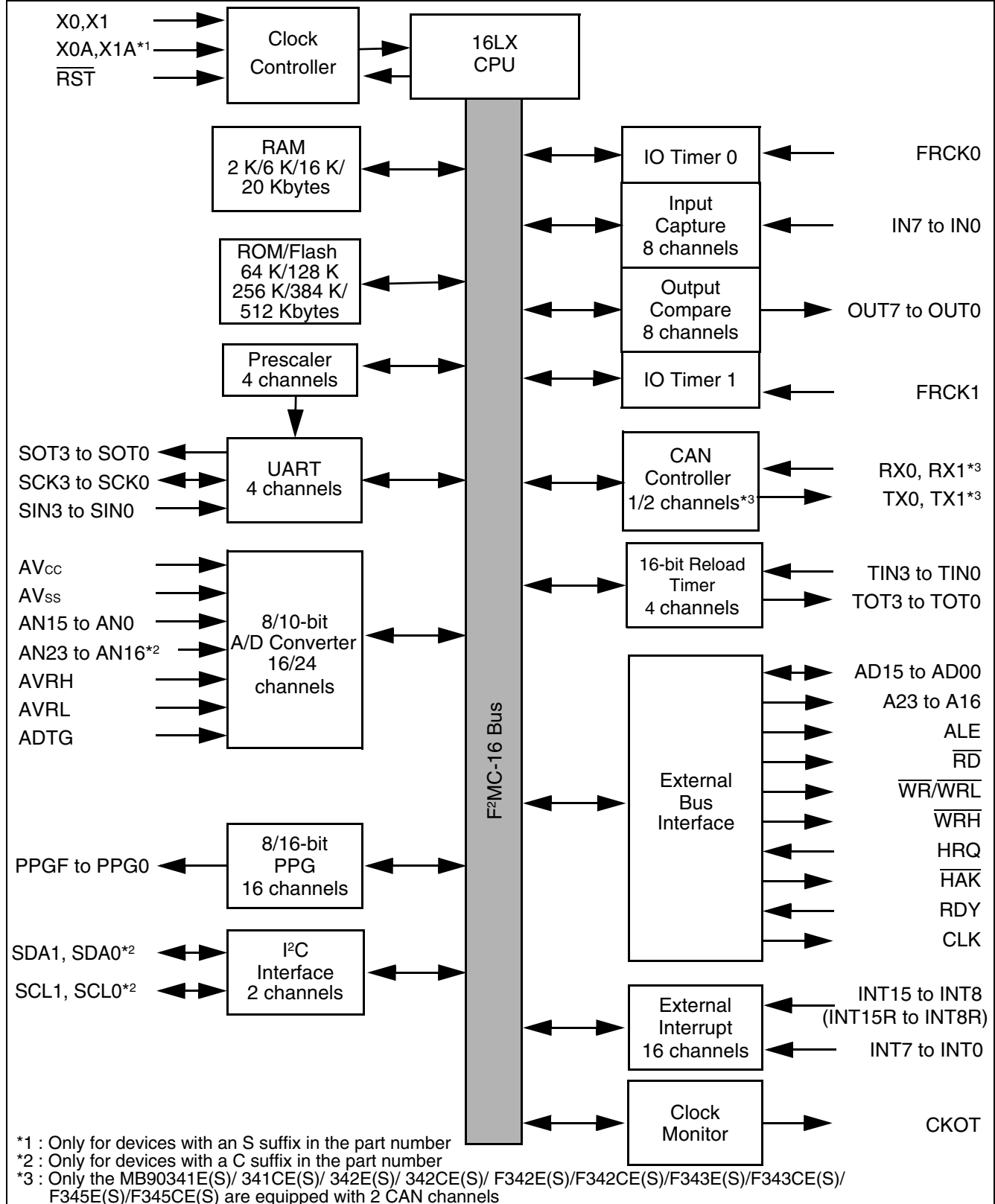

MB90340E Series

MEMORY MAP

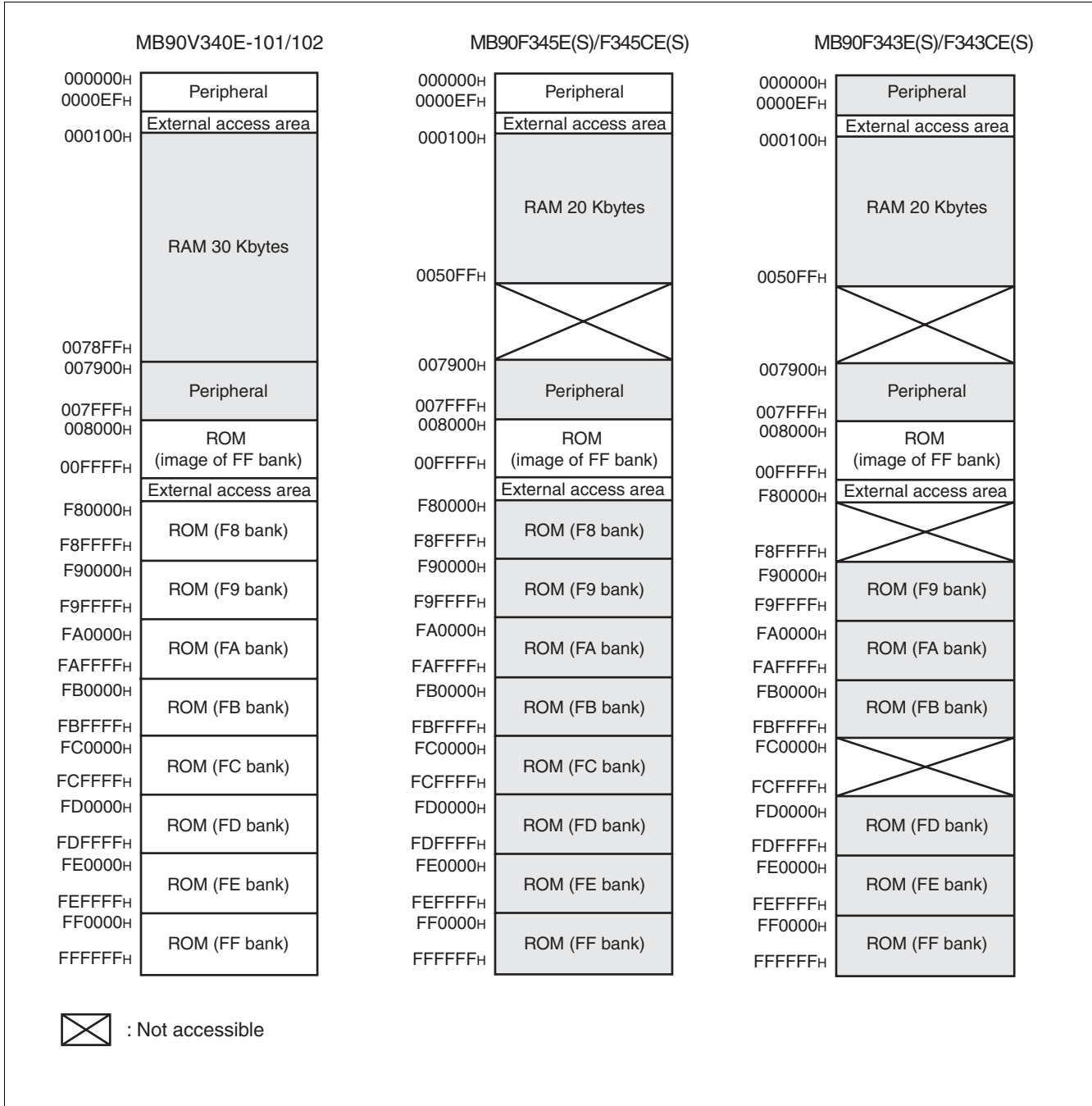

MB90340E Series

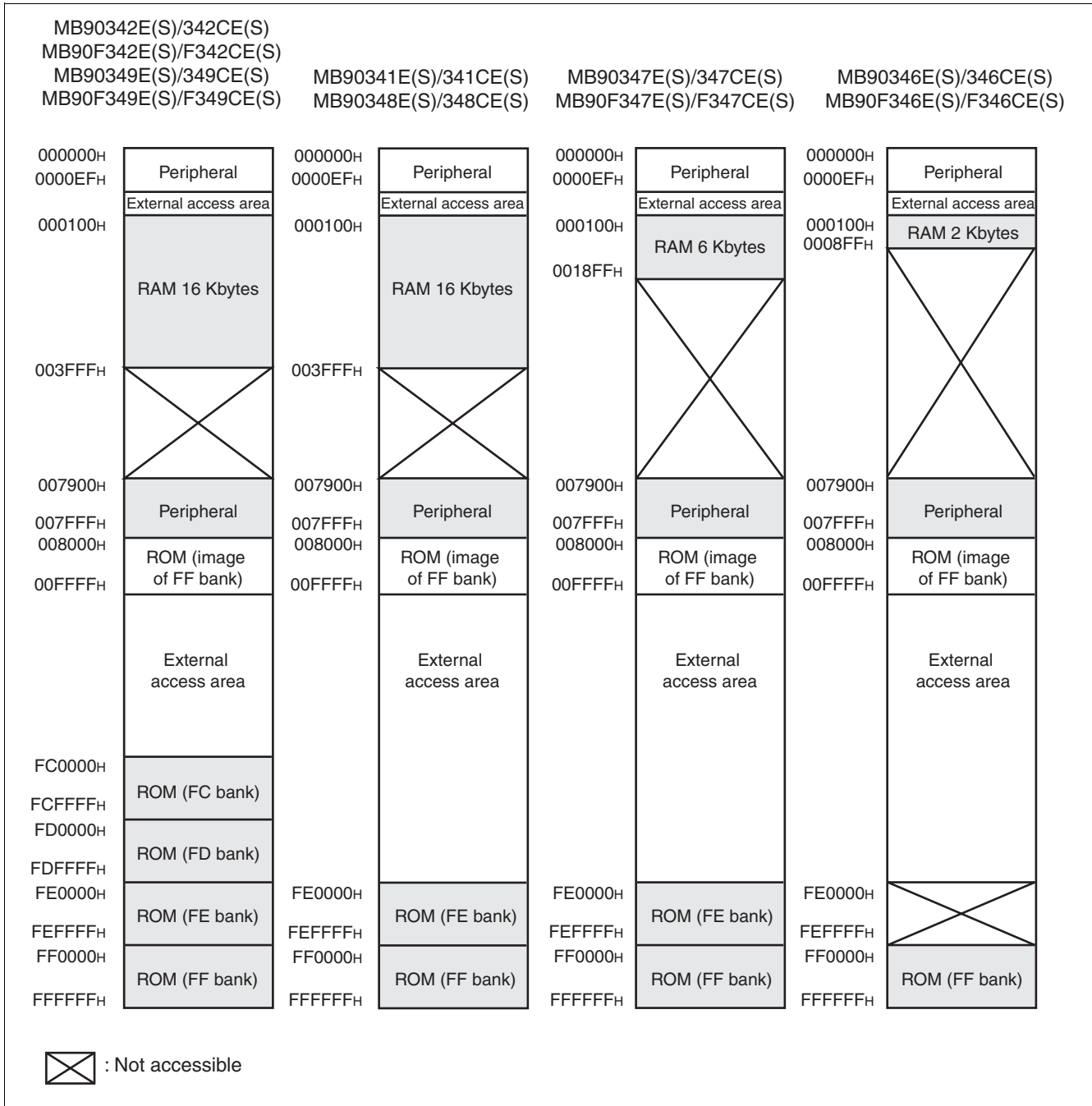

Note: An image of the data in the FF bank of ROM is visible in the upper part of bank 00, which makes it possible for the C compiler to use the small memory model. The lower 16 bits of addresses in the FF bank are the same as the lower 16 bits of addresses in the 00 bank so that tables stored in the ROM can be accessed without using the far specifier in the pointer declaration.

For example, when the address 00C000H is accessed, the data at FFC000H in ROM is actually accessed. The ROM area in bank FF exceeds 32 Kbytes, and its entire image cannot be shown in bank 00.

As a result, the image between FF8000H and FFFFFFFH is visible in bank 00, while the image between FF0000H and FF7FFFH is visible only in bank FF.

MB90340E Series

■ I/O MAP

| Address | Register | Abbreviation | Access | Resource name | Initial value |
|---------|-------------------------------------|--------------|--------|---------------|-----------------------|
| 00000H | Port 0 Data Register | PDR0 | R/W | Port 0 | XXXXXXXX _B |
| 00001H | Port 1 Data Register | PDR1 | R/W | Port 1 | XXXXXXXX _B |
| 00002H | Port 2 Data Register | PDR2 | R/W | Port 2 | XXXXXXXX _B |
| 00003H | Port 3 Data Register | PDR3 | R/W | Port 3 | XXXXXXXX _B |
| 00004H | Port 4 Data Register | PDR4 | R/W | Port 4 | XXXXXXXX _B |
| 00005H | Port 5 Data Register | PDR5 | R/W | Port 5 | XXXXXXXX _B |
| 00006H | Port 6 Data Register | PDR6 | R/W | Port 6 | XXXXXXXX _B |
| 00007H | Port 7 Data Register | PDR7 | R/W | Port 7 | XXXXXXXX _B |
| 00008H | Port 8 Data Register | PDR8 | R/W | Port 8 | XXXXXXXX _B |
| 00009H | Port 9 Data Register | PDR9 | R/W | Port 9 | XXXXXXXX _B |
| 0000AH | Port A Data Register | PDRA | R/W | Port A | XXXXXXXX _B |
| 0000BH | Port 5 Analog Input Enable Register | ADER5 | R/W | Port 5, A/D | 1111111 _B |
| 0000CH | Port 6 Analog Input Enable Register | ADER6 | R/W | Port 6, A/D | 1111111 _B |
| 0000DH | Port 7 Analog Input Enable Register | ADER7 | R/W | Port 7, A/D | 1111111 _B |
| 0000EH | Input Level Select Register 0 | ILSR0 | R/W | Ports | XXXXXXXX _B |
| 0000FH | Input Level Select Register 1 | ILSR1 | R/W | Ports | XXXX0XXX _B |
| 00010H | Port 0 Direction Register | DDR0 | R/W | Port 0 | 0000000 _B |
| 00011H | Port 1 Direction Register | DDR1 | R/W | Port 1 | 0000000 _B |
| 00012H | Port 2 Direction Register | DDR2 | R/W | Port 2 | 0000000 _B |
| 00013H | Port 3 Direction Register | DDR3 | R/W | Port 3 | 0000000 _B |
| 00014H | Port 4 Direction Register | DDR4 | R/W | Port 4 | 0000000 _B |
| 00015H | Port 5 Direction Register | DDR5 | R/W | Port 5 | 0000000 _B |
| 00016H | Port 6 Direction Register | DDR6 | R/W | Port 6 | 0000000 _B |
| 00017H | Port 7 Direction Register | DDR7 | R/W | Port 7 | 0000000 _B |
| 00018H | Port 8 Direction Register | DDR8 | R/W | Port 8 | 0000000 _B |
| 00019H | Port 9 Direction Register | DDR9 | R/W | Port 9 | 0000000 _B |
| 0001AH | Port A Direction Register | DDRA | R/W | Port A | 0000100 _B |
| 0001BH | Reserved | | | | |
| 0001CH | Port 0 Pull-up Control Register | PUCR0 | R/W | Port 0 | 0000000 _B |
| 0001DH | Port 1 Pull-up Control Register | PUCR1 | R/W | Port 1 | 0000000 _B |
| 0001EH | Port 2 Pull-up Control Register | PUCR2 | R/W | Port 2 | 0000000 _B |
| 0001FH | Port 3 Pull-up Control Register | PUCR3 | W, R/W | Port 3 | 0000000 _B |

(Continued)

MB90340E Series

| Address | Register | Abbreviation | Access | Resource name | Initial value |
|---------|---|--------------|-------------|---------------------------|-----------------------|
| 000020H | Serial Mode Register 0 | SMR0 | W,R/W | UART0 | 00000000 _B |
| 000021H | Serial Control Register 0 | SCR0 | W,R/W | | 00000000 _B |
| 000022H | Reception/Transmission Data Register 0 | RDR0/TDR0 | R/W | | 00000000 _B |
| 000023H | Serial Status Register 0 | SSR0 | R,R/W | | 00001000 _B |
| 000024H | Extended Communication Control Register 0 | ECCR0 | R,W, R/W | | 000000XX _B |
| 000025H | Extended Status/Control Register 0 | ESCR0 | R/W | | 00000100 _B |
| 000026H | Baud Rate Generator Register 00 | BGR00 | R/W | | 00000000 _B |
| 000027H | Baud Rate Generator Register 01 | BGR01 | R/W | | 00000000 _B |
| 000028H | Serial Mode Register 1 | SMR1 | W,R/W | UART1 | 00000000 _B |
| 000029H | Serial Control Register 1 | SCR1 | W,R/W | | 00000000 _B |
| 00002AH | Reception/Transmission Data Register 1 | RDR1/TDR1 | R/W | | 00000000 _B |
| 00002BH | Serial Status Register 1 | SSR1 | R,R/W | | 00001000 _B |
| 00002CH | Extended Communication Control Register 1 | ECCR1 | R,W, R/W | | 000000XX _B |
| 00002DH | Extended Status/Control Register 1 | ESCR1 | R/W | | 00000100 _B |
| 00002EH | Baud Rate Generator Register 10 | BGR10 | R/W | | 00000000 _B |
| 00002FH | Baud Rate Generator Register 11 | BGR11 | R/W | | 00000000 _B |
| 000030H | PPG 0 Operation Mode Control Register | PPGC0 | W,R/W | 16-bit PPG 0/1 | 0X000XX1 _B |
| 000031H | PPG 1 Operation Mode Control Register | PPGC1 | W,R/W | | 0X000001 _B |
| 000032H | PPG 0/PPG 1 Count Clock Select Register | PPG01 | R/W | | 000000X0 _B |
| 000033H | Reserved | | | | |
| 000034H | PPG 2 Operation Mode Control Register | PPGC2 | W,R/W | 16-bit PPG 2/3 | 0X000XX1 _B |
| 000035H | PPG 3 Operation Mode Control Register | PPGC3 | W,R/W | | 0X000001 _B |
| 000036H | PPG 2/PPG 3 Count Clock Select Register | PPG23 | R/W | | 000000X0 _B |
| 000037H | Reserved | | | | |
| 000038H | PPG 4 Operation Mode Control Register | PPGC4 | W,R/W | 16-bit PPG 4/5 | 0X000XX1 _B |
| 000039H | PPG 5 Operation Mode Control Register | PPGC5 | W,R/W | | 0X000001 _B |
| 00003AH | PPG 4/PPG 5 Clock Select Register | PPG45 | R/W | | 000000X0 _B |
| 00003BH | Address Detect Control Register 1 | PACSR1 | R/W | Address Match Detection 1 | 00000000 _B |
| 00003CH | PPG 6 Operation Mode Control Register | PPGC6 | W,R/W | 16-bit PPG 6/7 | 0X000XX1 _B |
| 00003DH | PPG 7 Operation Mode Control Register | PPGC7 | W,R/W | | 0X000001 _B |
| 00003EH | PPG 6/PPG 7 Count Clock Control Register | PPG67 | R/W | | 000000X0 _B |
| 00003FH | Reserved | | | | |

(Continued)

MB90340E Series

| Address | Register | Abbreviation | Access | Resource name | Initial value |
|---------------------|--|--------------|--------|--------------------|-----------------------|
| 000040 _H | PPG 8 Operation Mode Control Register | PPGC8 | W,R/W | 16-bit PPG 8/9 | 0X000XX1 _B |
| 000041 _H | PPG 9 Operation Mode Control Register | PPGC9 | W,R/W | | 0X000001 _B |
| 000042 _H | PPG 8/PPG 9 Count Clock Control Register | PPG89 | R/W | | 000000X0 _B |
| 000043 _H | Reserved | | | | |
| 000044 _H | PPG A Operation Mode Control Register | PPGCA | W,R/W | 16-bit PPG A/B | 0X000XX1 _B |
| 000045 _H | PPG B Operation Mode Control Register | PPGCB | W,R/W | | 0X000001 _B |
| 000046 _H | PPG A/PPG B Count Clock Select Register | PPGAB | R/W | | 000000X0 _B |
| 000047 _H | Reserved | | | | |
| 000048 _H | PPG C Operation Mode Control Register | PPGCC | W,R/W | 16-bit PPG C/D | 0X000XX1 _B |
| 000049 _H | PPG D Operation Mode Control Register | PPGCD | W,R/W | | 0X000001 _B |
| 00004A _H | PPG C/PPG D Count Clock Select Register | PPGCD | R/W | | 000000X0 _B |
| 00004B _H | Reserved | | | | |
| 00004C _H | PPG E Operation Mode Control Register | PPGCE | W,R/W | 16-bit PPG E/F | 0X000XX1 _B |
| 00004D _H | PPG F Operation Mode Control Register | PPGCF | W,R/W | | 0X000001 _B |
| 00004E _H | PPG E/PPG F Count Clock Select Register | PPGEF | R/W | | 000000X0 _B |
| 00004F _H | Reserved | | | | |
| 000050 _H | Input Capture Control Status 0/1 | ICS01 | R/W | Input Capture 0/1 | 00000000 _B |
| 000051 _H | Input Capture Edge 0/1 | ICE01 | R/W, R | | XXX0X0XX _B |
| 000052 _H | Input Capture Control Status 2/3 | ICS23 | R/W | Input Capture 2/3 | 00000000 _B |
| 000053 _H | Input Capture Edge 2/3 | ICE23 | R | | XXXXXXXX _B |
| 000054 _H | Input Capture Control Status 4/5 | ICS45 | R/W | Input Capture 4/5 | 00000000 _B |
| 000055 _H | Input Capture Edge 4/5 | ICE45 | R | | XXXXXXXX _B |
| 000056 _H | Input Capture Control Status 6/7 | ICS67 | R/W | Input Capture 6/7 | 00000000 _B |
| 000057 _H | Input Capture Edge 6/7 | ICE67 | R/W, R | | XXX000XX _B |
| 000058 _H | Output Compare Control Status 0 | OCS0 | R/W | Output Compare 0/1 | 0000XX00 _B |
| 000059 _H | Output Compare Control Status 1 | OCS1 | R/W | | 0XX00000 _B |
| 00005A _H | Output Compare Control Status 2 | OCS2 | R/W | Output Compare 2/3 | 0000XX00 _B |
| 00005B _H | Output Compare Control Status 3 | OCS3 | R/W | | 0XX00000 _B |
| 00005C _H | Output Compare Control Status 4 | OCS4 | R/W | Output Compare 4/5 | 0000XX00 _B |
| 00005D _H | Output Compare Control Status 5 | OCS5 | R/W | | 0XX00000 _B |
| 00005E _H | Output Compare Control Status 6 | OCS6 | R/W | Output Compare 6/7 | 0000XX00 _B |
| 00005F _H | Output Compare Control Status 7 | OCS7 | R/W | | 0XX00000 _B |

(Continued)

MB90340E Series

| Address | Register | Abbreviation | Access | Resource name | Initial value |
|--|---|--------------|--------|------------------------------|-------------------------|
| 000060 _H | Timer Control Status 0 | TMCSR0 | R/W | 16-bit Reload Timer 0 | 00000000 _B |
| 000061 _H | Timer Control Status 0 | TMCSR0 | R/W | | XXXX0000 _B |
| 000062 _H | Timer Control Status 1 | TMCSR1 | R/W | 16-bit Reload Timer 1 | 00000000 _B |
| 000063 _H | Timer Control Status 1 | TMCSR1 | R/W | | XXXX0000 _B |
| 000064 _H | Timer Control Status 2 | TMCSR2 | R/W | 16-bit Reload Timer 2 | 00000000 _B |
| 000065 _H | Timer Control Status 2 | TMCSR2 | R/W | | XXXX0000 _B |
| 000066 _H | Timer Control Status 3 | TMCSR3 | R/W | 16-bit Reload Timer 3 | 00000000 _B |
| 000067 _H | Timer Control Status 3 | TMCSR3 | R/W | | XXXX0000 _B |
| 000068 _H | A/D Control Status 0 | ADCS0 | R/W | A/D Converter | 000XXXX0 _B |
| 000069 _H | A/D Control Status 1 | ADCS1 | R/W | | 0000000X _B |
| 00006A _H | A/D Data 0 | ADCR0 | R | | 00000000 _B |
| 00006B _H | A/D Data 1 | ADCR1 | R | | XXXXXXXX00 _B |
| 00006C _H | ADC Setting 0 | ADSR0 | R/W | | 00000000 _B |
| 00006D _H | ADC Setting 1 | ADSR1 | R/W | | 00000000 _B |
| 00006E _H | Reserved | | | | |
| 00006F _H | ROM Mirror Function Select | ROMM | W | ROM Mirror | XXXXXXXX1 _B |
| 000070 _H to 00008F _H | Reserved for CAN Controller 0/1. Refer to "■ CAN CONTROLLERS" | | | | |
| 000090 _H to 00009A _H | Reserved | | | | |
| 00009B _H | DMA Descriptor Channel Specified Register | DCSR | R/W | DMA | 00000000 _B |
| 00009C _H | DMA Status L Register | DSRL | R/W | | 00000000 _B |
| 00009D _H | DMA Status H Register | DSRH | R/W | | 00000000 _B |
| 00009E _H | Address Detect Control Register 0 | PACSR0 | R/W | Address Match Detection 0 | 00000000 _B |
| 00009F _H | Delayed Interrupt Trigger/Release Register | DIRR | R/W | Delayed Interrupt | XXXXXXXX0 _B |
| 0000A0 _H | Low-power Mode Control Register | LPMCR | W,R/W | Low Power Control Circuit | 00011000 _B |
| 0000A1 _H | Clock Selection Register | CKSCR | R,R/W | Low Power Control Circuit | 11111100 _B |
| 0000A2 _H , 0000A3 _H | Reserved | | | | |
| 0000A4 _H | DMA Stop Status Register | DSSR | R/W | DMA | 00000000 _B |

(Continued)

MB90340E Series

| Address | Register | Abbreviation | Access | Resource name | Initial value |
|---------------------|---|--------------|--------|------------------------|------------------------|
| 0000A5 _H | Automatic Ready Function Select Register | ARSR | W | External Memory Access | 0011XX00 _B |
| 0000A6 _H | External Address Output Control Register | HACR | W | | 00000000 _B |
| 0000A7 _H | Bus Control Signal Selection Register | ECSR | W | | 0000000X _B |
| 0000A8 _H | Watchdog Control Register | WDTC | R,W | Watchdog Timer | XXXXXX111 _B |
| 0000A9 _H | Time Base Timer Control Register | TBTC | W,R/W | Time Base Timer | 1XX00100 _B |
| 0000AA _H | Watch Timer Control Register | WTC | R,R/W | Watch Timer | 1X001000 _B |
| 0000AB _H | Reserved | | | | |
| 0000AC _H | DMA Enable L Register | DERL | R/W | DMA | 00000000 _B |
| 0000AD _H | DMA Enable H Register | DERH | R/W | | 00000000 _B |
| 0000AE _H | Flash Control Status Register (Flash memory devices only. Otherwise reserved) | FMCS | R,R/W | Flash Memory | 000X0000 _B |
| 0000AF _H | Reserved | | | | |
| 0000B0 _H | Interrupt Control Register 00 | ICR00 | W,R/W | Interrupt Control | 00000111 _B |
| 0000B1 _H | Interrupt Control Register 01 | ICR01 | W,R/W | | 00000111 _B |
| 0000B2 _H | Interrupt Control Register 02 | ICR02 | W,R/W | | 00000111 _B |
| 0000B3 _H | Interrupt Control Register 03 | ICR03 | W,R/W | | 00000111 _B |
| 0000B4 _H | Interrupt Control Register 04 | ICR04 | W,R/W | | 00000111 _B |
| 0000B5 _H | Interrupt Control Register 05 | ICR05 | W,R/W | | 00000111 _B |
| 0000B6 _H | Interrupt Control Register 06 | ICR06 | W,R/W | | 00000111 _B |
| 0000B7 _H | Interrupt Control Register 07 | ICR07 | W,R/W | | 00000111 _B |
| 0000B8 _H | Interrupt Control Register 08 | ICR08 | W,R/W | | 00000111 _B |
| 0000B9 _H | Interrupt Control Register 09 | ICR09 | W,R/W | | 00000111 _B |
| 0000BA _H | Interrupt Control Register 10 | ICR10 | W,R/W | | 00000111 _B |
| 0000BB _H | Interrupt Control Register 11 | ICR11 | W,R/W | | 00000111 _B |
| 0000BC _H | Interrupt Control Register 12 | ICR12 | W,R/W | | 00000111 _B |
| 0000BD _H | Interrupt Control Register 13 | ICR13 | W,R/W | | 00000111 _B |
| 0000BE _H | Interrupt Control Register 14 | ICR14 | W,R/W | | 00000111 _B |
| 0000BF _H | Interrupt Control Register 15 | ICR15 | W,R/W | | 00000111 _B |
| 0000C0 _H | D/A Converter Data 0 | DAT0 | R/W | D/A Converter | XXXXXXXX _B |
| 0000C1 _H | D/A Converter Data 1 | DAT1 | R/W | | XXXXXXXX _B |
| 0000C2 _H | D/A Control 0 | DACR0 | R/W | | XXXXXXXX0 _B |
| 0000C3 _H | D/A Control 1 | DACR1 | R/W | | XXXXXXXX0 _B |

(Continued)

MB90340E Series

| Address | Register | Abbreviation | Access | Resource name | Initial value |
|--|---|--------------|-------------|----------------------|-----------------------|
| 0000C4 _H , 0000C5 _H | Reserved | | | | |
| 0000C6 _H | External Interrupt Enable 0 | ENIR0 | R/W | External Interrupt 0 | 00000000 _B |
| 0000C7 _H | External Interrupt Source 0 | EIRR0 | R/W | | XXXXXXXX _B |
| 0000C8 _H | External Interrupt Level Setting 0 | ELVR0 | R/W | | 00000000 _B |
| 0000C9 _H | External Interrupt Level Setting 0 | ELVR0 | R/W | | 00000000 _B |
| 0000CA _H | External Interrupt Enable 1 | ENIR1 | R/W | External Interrupt 1 | 00000000 _B |
| 0000CB _H | External Interrupt Source 1 | EIRR1 | R/W | | XXXXXXXX _B |
| 0000CC _H | External Interrupt Level Setting 1 | ELVR1 | R/W | | 00000000 _B |
| 0000CD _H | External Interrupt Level Setting 1 | ELVR1 | R/W | | 00000000 _B |
| 0000CE _H | External Interrupt Source Select | EISSR | R/W | | 00000000 _B |
| 0000CF _H | PLL/Sub clock Control Register | PSCCR | W | PLL | XXXX0000 _B |
| 0000D0 _H | DMA Buffer Address Pointer L Register | BAPL | R/W | DMA | XXXXXXXX _B |
| 0000D1 _H | DMA Buffer Address Pointer M Register | BAPM | R/W | | XXXXXXXX _B |
| 0000D2 _H | DMA Buffer Address Pointer H Register | BAPH | R/W | | XXXXXXXX _B |
| 0000D3 _H | DMA Control Register | DMACS | R/W | | XXXXXXXX _B |
| 0000D4 _H | I/O Register Address Pointer L Register | IOAL | R/W | | XXXXXXXX _B |
| 0000D5 _H | I/O Register Address Pointer H Register | IOAH | R/W | | XXXXXXXX _B |
| 0000D6 _H | Data Counter L Register | DCTL | R/W | | XXXXXXXX _B |
| 0000D7 _H | Data Counter H Register | DCTH | R/W | | XXXXXXXX _B |
| 0000D8 _H | Serial Mode Register 2 | SMR2 | W,R/W | UART2 | 00000000 _B |
| 0000D9 _H | Serial Control Register 2 | SCR2 | W,R/W | | 00000000 _B |
| 0000DA _H | Reception/Transmission Data Register 2 | RDR2/TDR2 | R/W | | 00000000 _B |
| 0000DB _H | Serial Status Register 2 | SSR2 | R,R/W | | 00001000 _B |
| 0000DC _H | Extended Communication Control Register 2 | ECCR2 | R,W, R/W | | 000000XX _B |
| 0000DD _H | Extended Status Control Register 2 | ESCR2 | R/W | | 00000100 _B |
| 0000DE _H | Baud Rate Generator Register 20 | BGR20 | R/W | | 00000000 _B |
| 0000DF _H | Baud Rate Generator Register 21 | BGR21 | R/W | | 00000000 _B |
| 0000E0 _H to 0000EF _H | Reserved for CAN Controller 2. Refer to “■ CAN CONTROLLERS” | | | | |
| 0000F0 _H to 0000FF _H | External | | | | |

(Continued)

MB90340E Series

| Address | Register | Abbreviation | Access | Resource name | Initial value |
|---------------------|--------------------|--------------|--------|-------------------|-----------------------|
| 007900 _H | Reload Register L0 | PRLLO | R/W | 16-bit PPG 0/1 | XXXXXXXX _B |
| 007901 _H | Reload Register H0 | PRLH0 | R/W | | XXXXXXXX _B |
| 007902 _H | Reload Register L1 | PRLLO1 | R/W | | XXXXXXXX _B |
| 007903 _H | Reload Register H1 | PRLH1 | R/W | | XXXXXXXX _B |
| 007904 _H | Reload Register L2 | PRLLO2 | R/W | 16-bit PPG 2/3 | XXXXXXXX _B |
| 007905 _H | Reload Register H2 | PRLH2 | R/W | | XXXXXXXX _B |
| 007906 _H | Reload Register L3 | PRLLO3 | R/W | | XXXXXXXX _B |
| 007907 _H | Reload Register H3 | PRLH3 | R/W | | XXXXXXXX _B |
| 007908 _H | Reload Register L4 | PRLLO4 | R/W | 16-bit PPG 4/5 | XXXXXXXX _B |
| 007909 _H | Reload Register H4 | PRLH4 | R/W | | XXXXXXXX _B |
| 00790A _H | Reload Register L5 | PRLLO5 | R/W | | XXXXXXXX _B |
| 00790B _H | Reload Register H5 | PRLH5 | R/W | | XXXXXXXX _B |
| 00790C _H | Reload Register L6 | PRLLO6 | R/W | 16-bit PPG 6/7 | XXXXXXXX _B |
| 00790D _H | Reload Register H6 | PRLH6 | R/W | | XXXXXXXX _B |
| 00790E _H | Reload Register L7 | PRLLO7 | R/W | | XXXXXXXX _B |
| 00790F _H | Reload Register H7 | PRLH7 | R/W | | XXXXXXXX _B |
| 007910 _H | Reload Register L8 | PRLLO8 | R/W | 16-bit PPG 8/9 | XXXXXXXX _B |
| 007911 _H | Reload Register H8 | PRLH8 | R/W | | XXXXXXXX _B |
| 007912 _H | Reload Register L9 | PRLLO9 | R/W | | XXXXXXXX _B |
| 007913 _H | Reload Register H9 | PRLH9 | R/W | | XXXXXXXX _B |
| 007914 _H | Reload Register LA | PRLLOA | R/W | 16-bit PPG A/B | XXXXXXXX _B |
| 007915 _H | Reload Register HA | PRLHA | R/W | | XXXXXXXX _B |
| 007916 _H | Reload Register LB | PRLLOB | R/W | | XXXXXXXX _B |
| 007917 _H | Reload Register HB | PRLHB | R/W | | XXXXXXXX _B |
| 007918 _H | Reload Register LC | PRLLOC | R/W | 16-bit PPG C/D | XXXXXXXX _B |
| 007919 _H | Reload Register HC | PRLHC | R/W | | XXXXXXXX _B |
| 00791A _H | Reload Register LD | PRLLOD | R/W | | XXXXXXXX _B |
| 00791B _H | Reload Register HD | PRLHD | R/W | | XXXXXXXX _B |
| 00791C _H | Reload Register LE | PRLLOE | R/W | 16-bit PPG E/F | XXXXXXXX _B |
| 00791D _H | Reload Register HE | PRLHE | R/W | | XXXXXXXX _B |
| 00791E _H | Reload Register LF | PRLLOF | R/W | | XXXXXXXX _B |
| 00791F _H | Reload Register HF | PRLHF | R/W | | XXXXXXXX _B |
| 007920 _H | Input Capture 0 | IPCP0 | R | Input Capture 0/1 | XXXXXXXX _B |
| 007921 _H | Input Capture 0 | IPCP0 | R | | XXXXXXXX _B |
| 007922 _H | Input Capture 1 | IPCP1 | R | | XXXXXXXX _B |
| 007923 _H | Input Capture 1 | IPCP1 | R | | XXXXXXXX _B |

(Continued)

MB90340E Series

| Address | Register | Abbreviation | Access | Resource name | Initial value |
|---------------------|------------------------|--------------|--------|--------------------|------------------------|
| 007924 _H | Input Capture 2 | IPCP2 | R | Input Capture 2/3 | XXXXXXXX _B |
| 007925 _H | Input Capture 2 | IPCP2 | R | | XXXXXXXX _B |
| 007926 _H | Input Capture 3 | IPCP3 | R | | XXXXXXXX _B |
| 007927 _H | Input Capture 3 | IPCP3 | R | | XXXXXXXX _B |
| 007928 _H | Input Capture 4 | IPCP4 | R | Input Capture 4/5 | XXXXXXXX _B |
| 007929 _H | Input Capture 4 | IPCP4 | R | | XXXXXXXX _B |
| 00792A _H | Input Capture 5 | IPCP5 | R | | XXXXXXXX _B |
| 00792B _H | Input Capture 5 | IPCP5 | R | | XXXXXXXX _B |
| 00792C _H | Input Capture 6 | IPCP6 | R | Input Capture 6/7 | XXXXXXXX _B |
| 00792D _H | Input Capture 6 | IPCP6 | R | | XXXXXXXX _B |
| 00792E _H | Input Capture 7 | IPCP7 | R | | XXXXXXXX _B |
| 00792F _H | Input Capture 7 | IPCP7 | R | | XXXXXXXX _B |
| 007930 _H | Output Compare 0 | OCCP0 | R/W | Output Compare 0/1 | XXXXXXXX _B |
| 007931 _H | Output Compare 0 | OCCP0 | R/W | | XXXXXXXX _B |
| 007932 _H | Output Compare 1 | OCCP1 | R/W | | XXXXXXXX _B |
| 007933 _H | Output Compare 1 | OCCP1 | R/W | | XXXXXXXX _B |
| 007934 _H | Output Compare 2 | OCCP2 | R/W | Output Compare 2/3 | XXXXXXXX _B |
| 007935 _H | Output Compare 2 | OCCP2 | R/W | | XXXXXXXX _B |
| 007936 _H | Output Compare 3 | OCCP3 | R/W | | XXXXXXXX _B |
| 007937 _H | Output Compare 3 | OCCP3 | R/W | | XXXXXXXX _B |
| 007938 _H | Output Compare 4 | OCCP4 | R/W | Output Compare 4/5 | XXXXXXXX _B |
| 007939 _H | Output Compare 4 | OCCP4 | R/W | | XXXXXXXX _B |
| 00793A _H | Output Compare 5 | OCCP5 | R/W | | XXXXXXXX _B |
| 00793B _H | Output Compare 5 | OCCP5 | R/W | | XXXXXXXX _B |
| 00793C _H | Output Compare 6 | OCCP6 | R/W | Output Compare 6/7 | XXXXXXXX _B |
| 00793D _H | Output Compare 6 | OCCP6 | R/W | | XXXXXXXX _B |
| 00793E _H | Output Compare 7 | OCCP7 | R/W | | XXXXXXXX _B |
| 00793F _H | Output Compare 7 | OCCP7 | R/W | | XXXXXXXX _B |
| 007940 _H | Timer Data 0 | TCDT0 | R/W | I/O Timer 0 | 0000000 _B |
| 007941 _H | Timer Data 0 | TCDT0 | R/W | | 0000000 _B |
| 007942 _H | Timer Control Status 0 | TCCSL0 | R/W | | 0000000 _B |
| 007943 _H | Timer Control Status 0 | TCCSH0 | R/W | | 0XXXXXXXX _B |
| 007944 _H | Timer Data 1 | TCDT1 | R/W | I/O Timer 1 | 0000000 _B |
| 007945 _H | Timer Data 1 | TCDT1 | R/W | | 0000000 _B |
| 007946 _H | Timer Control Status 1 | TCCSL1 | R/W | | 0000000 _B |
| 007947 _H | Timer Control Status 1 | TCCSH1 | R/W | | 0XXXXXXXX _B |

(Continued)

MB90340E Series

| Address | Register | Abbreviation | Access | Resource name | Initial value | |
|--|---|-----------------|-------------|--------------------------|------------------------|-----------------------|
| 007948 _H | Timer 0/Reload 0 | TMR0/ TMRLR0 | R/W | 16-bit Reload Timer 0 | XXXXXXXX _B | |
| 007949 _H | | | R/W | | XXXXXXXX _B | |
| 00794A _H | Timer 1/Reload 1 | TMR1/ TMRLR1 | R/W | 16-bit Reload Timer 1 | XXXXXXXX _B | |
| 00794B _H | | | R/W | | XXXXXXXX _B | |
| 00794C _H | Timer 2/Reload 2 | TMR2/ TMRLR2 | R/W | 16-bit Reload Timer 2 | XXXXXXXX _B | |
| 00794D _H | | | R/W | | XXXXXXXX _B | |
| 00794E _H | Timer 3/Reload 3 | TMR3/ TMRLR3 | R/W | 16-bit Reload Timer 3 | XXXXXXXX _B | |
| 00794F _H | | | R/W | | XXXXXXXX _B | |
| 007950 _H | Serial Mode Register 3 | SMR3 | W,R/W | UART3 | 00000000 _B | |
| 007951 _H | Serial Control Register 3 | SCR3 | W,R/W | | 00000000 _B | |
| 007952 _H | Reception/Transmission Data Register 3 | RDR3/TDR3 | R/W | | 00000000 _B | |
| 007953 _H | Serial Status Register 3 | SSR3 | R,R/W | | 00001000 _B | |
| 007954 _H | Extended Communication Control Register 3 | ECCR3 | R,W, R/W | | 000000XX _B | |
| 007955 _H | Extended Status Control Register | ESCR3 | R/W | | 00000100 _B | |
| 007956 _H | Baud Rate Generator Register 30 | BGR30 | R/W | | 00000000 _B | |
| 007957 _H | Baud Rate Generator Register 31 | BGR31 | R/W | | 00000000 _B | |
| 007958 _H | Serial Mode Register 4 | SMR4 | W,R/W | | UART4 | 00000000 _B |
| 007959 _H | Serial Control Register 4 | SCR4 | W,R/W | | | 00000000 _B |
| 00795A _H | Reception/Transmission Data Register 4 | RDR4/TDR4 | R/W | 00000000 _B | | |
| 00795B _H | Serial Status Register 4 | SSR4 | R,R/W | 00001000 _B | | |
| 00795C _H | Extended Communication Control Register 4 | ECCR4 | R,W, R/W | 000000XX _B | | |
| 00795D _H | Extended Status Control Register | ESCR4 | R/W | 00000100 _B | | |
| 00795E _H | Baud Rate Generator Register 40 | BGR40 | R/W | 00000000 _B | | |
| 00795F _H | Baud Rate Generator Register 41 | BGR41 | R/W | 00000000 _B | | |
| 007960 _H to 00796B _H | Reserved | | | | | |
| 00796C _H | Clock Output Enable Register | CLKR | R/W | Clock Monitor | XXXX0000 _B | |
| 00796D _H | Reserved | | | | | |
| 00796E _H | CAN Direct Mode Register | CDMR | R/W | CAN Clock sync | XXXXXXXX0 _B | |
| 00796F _H | CAN Switch Register | CANSWR | R/W | CAN 0/1 | XXXXXXXX0 _B | |

(Continued)

MB90340E Series

| Address | Register | Abbreviation | Access | Resource name | Initial value |
|--|---|--------------|--------|------------------------------|-----------------------|
| 007970 _H | I ² C Bus Status Register 0 | IBSR0 | R | I ² C Interface 0 | 00000000 _B |
| 007971 _H | I ² C Bus Control Register 0 | IBCR0 | W,R/W | | 00000000 _B |
| 007972 _H | I ² C 10-bit Slave Address Register 0 | ITBAL0 | R/W | | 00000000 _B |
| 007973 _H | | ITBAH0 | R/W | | 00000000 _B |
| 007974 _H | I ² C 10-bit Slave Address Mask Register 0 | ITMKL0 | R/W | | 11111111 _B |
| 007975 _H | | ITMKH0 | R/W | | 00111111 _B |
| 007976 _H | I ² C 7-bit Slave Address Register 0 | ISBA0 | R/W | | 00000000 _B |
| 007977 _H | I ² C 7-bit Slave Address Mask Register 0 | ISMK0 | R/W | | 01111111 _B |
| 007978 _H | I ² C Data Register 0 | IDAR0 | R/W | | 00000000 _B |
| 007979 _H , 00797A _H | Reserved | | | | |
| 00797B _H | I ² C Clock Control Register 0 | ICCR0 | R/W | I ² C Interface 0 | 00011111 _B |
| 00797C _H to 00797F _H | Reserved | | | | |
| 007980 _H | I ² C Bus Status Register 1 | IBSR1 | R | I ² C Interface 1 | 00000000 _B |
| 007981 _H | I ² C Bus Control Register 1 | IBCR1 | W,R/W | | 00000000 _B |
| 007982 _H | I ² C 10-bit Slave Address Register 1 | ITBAL1 | R/W | | 00000000 _B |
| 007983 _H | | ITBAH1 | R/W | | 00000000 _B |
| 007984 _H | I ² C 10-bit Slave Address Mask Register 1 | ITMKL1 | R/W | | 11111111 _B |
| 007985 _H | | ITMKH1 | R/W | | 00111111 _B |
| 007986 _H | I ² C 7-bit Slave Address Register 1 | ISBA1 | R/W | | 00000000 _B |
| 007987 _H | I ² C 7-bit Slave Address Mask Register 1 | ISMK1 | R/W | | 01111111 _B |
| 007988 _H | I ² C Data Register 1 | IDAR1 | R/W | | 00000000 _B |
| 007989 _H , 00798A _H | Reserved | | | | |
| 00798B _H | I ² C Clock Control Register 1 | ICCR1 | R/W | I ² C Interface 1 | 00011111 _B |
| 00798C _H to 0079C1 _H | Reserved | | | | |
| 0079C2 _H | Clock Modulator Control Register | CMCR | R, R/W | Clock Modulator | 0001X000 _B |
| 0079C3 _H to 0079DF _H | Reserved | | | | |

(Continued)

MB90340E Series

(Continued)

| Address | Register | Abbreviation | Access | Resource name | Initial value |
|--|---|--------------|--------|---------------------------|-----------------------|
| 0079E0 _H | Detect Address Setting 0 | PADR0 | R/W | Address Match Detection 0 | XXXXXXXX _B |
| 0079E1 _H | Detect Address Setting 0 | PADR0 | R/W | | XXXXXXXX _B |
| 0079E2 _H | Detect Address Setting 0 | PADR0 | R/W | | XXXXXXXX _B |
| 0079E3 _H | Detect Address Setting 1 | PADR1 | R/W | | XXXXXXXX _B |
| 0079E4 _H | Detect Address Setting 1 | PADR1 | R/W | | XXXXXXXX _B |
| 0079E5 _H | Detect Address Setting 1 | PADR1 | R/W | | XXXXXXXX _B |
| 0079E6 _H | Detect Address Setting 2 | PADR2 | R/W | | XXXXXXXX _B |
| 0079E7 _H | Detect Address Setting 2 | PADR2 | R/W | | XXXXXXXX _B |
| 0079E8 _H | Detect Address Setting 2 | PADR2 | R/W | | XXXXXXXX _B |
| 0079E9 _H to 0079EF _H | Reserved | | | | |
| 0079F0 _H | Detect Address Setting 3 | PADR3 | R/W | Address Match Detection 1 | XXXXXXXX _B |
| 0079F1 _H | Detect Address Setting 3 | PADR3 | R/W | | XXXXXXXX _B |
| 0079F2 _H | Detect Address Setting 3 | PADR3 | R/W | | XXXXXXXX _B |
| 0079F3 _H | Detect Address Setting 4 | PADR4 | R/W | | XXXXXXXX _B |
| 0079F4 _H | Detect Address Setting 4 | PADR4 | R/W | | XXXXXXXX _B |
| 0079F5 _H | Detect Address Setting 4 | PADR4 | R/W | | XXXXXXXX _B |
| 0079F6 _H | Detect Address Setting 5 | PADR5 | R/W | | XXXXXXXX _B |
| 0079F7 _H | Detect Address Setting 5 | PADR5 | R/W | | XXXXXXXX _B |
| 0079F8 _H | Detect Address Setting 5 | PADR5 | R/W | | XXXXXXXX _B |
| 0079F9 _H to 0079FF _H | Reserved | | | | |
| 007A00 _H to 007AFF _H | Reserved for CAN Controller 0. Refer to “■ CAN CONTROLLERS” | | | | |
| 007B00 _H to 007BFF _H | Reserved for CAN Controller 0. Refer to “■ CAN CONTROLLERS” | | | | |
| 007C00 _H to 007CFF _H | Reserved for CAN Controller 1. Refer to “■ CAN CONTROLLERS” | | | | |
| 007D00 _H to 007DFF _H | Reserved for CAN Controller 1. Refer to “■ CAN CONTROLLERS” | | | | |
| 007E00 _H to 007FFF _H | Reserved | | | | |

Notes : • Initial value of “X” represents unknown value.

- Any write access to reserved addresses in I/O map should not be performed. A read access to reserved addresses results in reading “X”.

■ CAN CONTROLLERS

The CAN controller has the following features:

- Conforms to CAN Specification Version 2.0 Part A and B
 - Supports transmission/reception in standard frame and extended frame formats
- Supports transmission of data frames by receiving remote frames
- 16 transmission/reception message buffers
 - 29-bit ID and 8-byte data
 - Multi-level message buffer configuration
- Provides full-bit comparison, full-bit mask, acceptance register 0/acceptance register 1 for each message buffer as ID acceptance mask
 - Two acceptance mask registers in either standard frame format or extended frame formats
- Bit rate programmable from 10 kbps to 2 Mbps (when input clock is at 16 MHz)

List of Control Registers (1)

| Address | | Register | Abbreviation | Access | Initial Value |
|---------------------|---------------------|-------------------------------------|--------------|--------|--|
| CAN0 | CAN1 | | | | |
| 000070 _H | 000080 _H | Message Buffer Valid Register | BVALR | R/W | 00000000 _B 00000000 _B |
| 000071 _H | 000081 _H | | | | |
| 000072 _H | 000082 _H | Transmit Request Register | TREQR | R/W | 00000000 _B 00000000 _B |
| 000073 _H | 000083 _H | | | | |
| 000074 _H | 000084 _H | Transmit Cancel Register | TCANR | W | 00000000 _B 00000000 _B |
| 000075 _H | 000085 _H | | | | |
| 000076 _H | 000086 _H | Transmission Complete Register | TCR | R/W | 00000000 _B 00000000 _B |
| 000077 _H | 000087 _H | | | | |
| 000078 _H | 000088 _H | Receive Complete Register | RCR | R/W | 00000000 _B 00000000 _B |
| 000079 _H | 000089 _H | | | | |
| 00007A _H | 00008A _H | Remote Request Receiving Register | RRTRR | R/W | 00000000 _B 00000000 _B |
| 00007B _H | 00008B _H | | | | |
| 00007C _H | 00008C _H | Receive Overrun Register | ROVRR | R/W | 00000000 _B 00000000 _B |
| 00007D _H | 00008D _H | | | | |
| 00007E _H | 00008E _H | Reception Interrupt Enable Register | RIER | R/W | 00000000 _B 00000000 _B |
| 00007F _H | 00008F _H | | | | |

MB90340E Series

List of Control Registers (2)

| Address | | Register | Abbreviation | Access | Initial Value |
|---------|---------|---------------------------------------|--------------|------------------|--------------------------|
| CAN0 | CAN1 | | | | |
| 007B00H | 007D00H | Control Status Register | CSR | R/W, W R/W, R | 0XXXX0X1B 00XXX000B |
| 007B01H | 007D01H | | | | |
| 007B02H | 007D02H | Last Event Indicator Register | LEIR | R/W | 000X0000B XXXXXXXXXB |
| 007B03H | 007D03H | | | | |
| 007B04H | 007D04H | Receive And Transmit Error Counter | RTEC | R | 00000000B 00000000B |
| 007B05H | 007D05H | | | | |
| 007B06H | 007D06H | Bit Timing Register | BTR | R/W | 11111111B X1111111B |
| 007B07H | 007D07H | | | | |
| 007B08H | 007D08H | IDE Register | IDER | R/W | XXXXXXXXXB XXXXXXXXXB |
| 007B09H | 007D09H | | | | |
| 007B0AH | 007D0AH | Transmit RTR Register | TRTRR | R/W | 00000000B 00000000B |
| 007B0BH | 007D0BH | | | | |
| 007B0CH | 007D0CH | Remote Frame Receive Waiting Register | RFWTR | R/W | XXXXXXXXXB XXXXXXXXXB |
| 007B0DH | 007D0DH | | | | |
| 007B0EH | 007D0EH | Transmit Interrupt Enable Register | TIER | R/W | 00000000B 00000000B |
| 007B0FH | 007D0FH | | | | |
| 007B10H | 007D10H | Acceptance Mask Select Register | AMSR | R/W | XXXXXXXXXB XXXXXXXXXB |
| 007B11H | 007D11H | | | | |
| 007B12H | 007D12H | | | | XXXXXXXXXB XXXXXXXXXB |
| 007B13H | 007D13H | | | | |
| 007B14H | 007D14H | Acceptance Mask Register 0 | AMR0 | R/W | XXXXXXXXXB XXXXXXXXXB |
| 007B15H | 007D15H | | | | |
| 007B16H | 007D16H | | | | XXXXXXXXXB XXXXXXXXXB |
| 007B17H | 007D17H | | | | |
| 007B18H | 007D18H | Acceptance Mask Register 1 | AMR1 | R/W | XXXXXXXXXB XXXXXXXXXB |
| 007B19H | 007D19H | | | | |
| 007B1AH | 007D1AH | | | | XXXXXXXXXB XXXXXXXXXB |
| 007B1BH | 007D1BH | | | | |

List of Message Buffers (ID Registers) (1)

| Address | | Register | Abbreviation | Access | Initial Value |
|--|--|-------------------------|--------------|--------|--|
| CAN0 | CAN1 | | | | |
| 007A00 _H to 007A1F _H | 007C00 _H to 007C1F _H | General- Purpose RAM | — | R/W | XXXXXXXX _B to XXXXXXXX _B |
| 007A20 _H | 007C20 _H | ID Register 0 | IDR0 | R/W | XXXXXXXX _B XXXXXXXX _B |
| 007A21 _H | 007C21 _H | | | | XXXXXXXX _B XXXXXXXX _B |
| 007A22 _H | 007C22 _H | | | | XXXXXXXX _B XXXXXXXX _B |
| 007A23 _H | 007C23 _H | ID Register 1 | IDR1 | R/W | XXXXXXXX _B XXXXXXXX _B |
| 007A24 _H | 007C24 _H | | | | XXXXXXXX _B XXXXXXXX _B |
| 007A25 _H | 007C25 _H | | | | XXXXXXXX _B XXXXXXXX _B |
| 007A26 _H | 007C26 _H | | | | XXXXXXXX _B XXXXXXXX _B |
| 007A27 _H | 007C27 _H | ID Register 2 | IDR2 | R/W | XXXXXXXX _B XXXXXXXX _B |
| 007A28 _H | 007C28 _H | | | | XXXXXXXX _B XXXXXXXX _B |
| 007A29 _H | 007C29 _H | | | | XXXXXXXX _B XXXXXXXX _B |
| 007A2A _H | 007C2A _H | | | | XXXXXXXX _B XXXXXXXX _B |
| 007A2B _H | 007C2B _H | ID Register 3 | IDR3 | R/W | XXXXXXXX _B XXXXXXXX _B |
| 007A2C _H | 007C2C _H | | | | XXXXXXXX _B XXXXXXXX _B |
| 007A2D _H | 007C2D _H | | | | XXXXXXXX _B XXXXXXXX _B |
| 007A2E _H | 007C2E _H | | | | XXXXXXXX _B XXXXXXXX _B |
| 007A2F _H | 007C2F _H | ID Register 4 | IDR4 | R/W | XXXXXXXX _B XXXXXXXX _B |
| 007A30 _H | 007C30 _H | | | | XXXXXXXX _B XXXXXXXX _B |
| 007A31 _H | 007C31 _H | | | | XXXXXXXX _B XXXXXXXX _B |
| 007A32 _H | 007C32 _H | | | | XXXXXXXX _B XXXXXXXX _B |
| 007A33 _H | 007C33 _H | ID Register 5 | IDR5 | R/W | XXXXXXXX _B XXXXXXXX _B |
| 007A34 _H | 007C34 _H | | | | XXXXXXXX _B XXXXXXXX _B |
| 007A35 _H | 007C35 _H | | | | XXXXXXXX _B XXXXXXXX _B |
| 007A36 _H | 007C36 _H | | | | XXXXXXXX _B XXXXXXXX _B |
| 007A37 _H | 007C37 _H | ID Register 6 | IDR6 | R/W | XXXXXXXX _B XXXXXXXX _B |
| 007A38 _H | 007C38 _H | | | | XXXXXXXX _B XXXXXXXX _B |
| 007A39 _H | 007C39 _H | | | | XXXXXXXX _B XXXXXXXX _B |
| 007A3A _H | 007C3A _H | | | | XXXXXXXX _B XXXXXXXX _B |
| 007A3B _H | 007C3B _H | ID Register 7 | IDR7 | R/W | XXXXXXXX _B XXXXXXXX _B |
| 007A3C _H | 007C3C _H | | | | XXXXXXXX _B XXXXXXXX _B |
| 007A3D _H | 007C3D _H | | | | XXXXXXXX _B XXXXXXXX _B |
| 007A3E _H | 007C3E _H | | | | XXXXXXXX _B XXXXXXXX _B |
| 007A3F _H | 007C3F _H | | | | XXXXXXXX _B XXXXXXXX _B |

MB90340E Series

List of Message Buffers (ID Registers) (2)

| Address | | Register | Abbreviation | Access | Initial Value |
|---------|---------|----------------|--------------|--------|---------------|
| CAN0 | CAN1 | | | | |
| 007A40H | 007C40H | ID Register 8 | IDR8 | R/W | XXXXXXXXXB |
| 007A41H | 007C41H | | | | XXXXXXXXXB |
| 007A42H | 007C42H | | | | XXXXXXXXXB |
| 007A43H | 007C43H | | | | XXXXXXXXXB |
| 007A44H | 007C44H | ID Register 9 | IDR9 | R/W | XXXXXXXXXB |
| 007A45H | 007C45H | | | | XXXXXXXXXB |
| 007A46H | 007C46H | | | | XXXXXXXXXB |
| 007A47H | 007C47H | | | | XXXXXXXXXB |
| 007A48H | 007C48H | ID Register 10 | IDR10 | R/W | XXXXXXXXXB |
| 007A49H | 007C49H | | | | XXXXXXXXXB |
| 007A4AH | 007C4AH | | | | XXXXXXXXXB |
| 007A4BH | 007C4BH | | | | XXXXXXXXXB |
| 007A4CH | 007C4CH | ID Register 11 | IDR11 | R/W | XXXXXXXXXB |
| 007A4DH | 007C4DH | | | | XXXXXXXXXB |
| 007A4EH | 007C4EH | | | | XXXXXXXXXB |
| 007A4FH | 007C4FH | | | | XXXXXXXXXB |
| 007A50H | 007C50H | ID Register 12 | IDR12 | R/W | XXXXXXXXXB |
| 007A51H | 007C51H | | | | XXXXXXXXXB |
| 007A52H | 007C52H | | | | XXXXXXXXXB |
| 007A53H | 007C53H | | | | XXXXXXXXXB |
| 007A54H | 007C54H | ID Register 13 | IDR13 | R/W | XXXXXXXXXB |
| 007A55H | 007C55H | | | | XXXXXXXXXB |
| 007A56H | 007C56H | | | | XXXXXXXXXB |
| 007A57H | 007C57H | | | | XXXXXXXXXB |
| 007A58H | 007C58H | ID Register 14 | IDR14 | R/W | XXXXXXXXXB |
| 007A59H | 007C59H | | | | XXXXXXXXXB |
| 007A5AH | 007C5AH | | | | XXXXXXXXXB |
| 007A5BH | 007C5BH | | | | XXXXXXXXXB |
| 007A5CH | 007C5CH | ID Register 15 | IDR15 | R/W | XXXXXXXXXB |
| 007A5DH | 007C5DH | | | | XXXXXXXXXB |
| 007A5EH | 007C5EH | | | | XXXXXXXXXB |
| 007A5FH | 007C5FH | | | | XXXXXXXXXB |

List of Message Buffers (DLC Registers and Data Registers) (1)

| Address | | Register | Abbreviation | Access | Initial Value |
|---------|---------|-----------------|--------------|--------|---------------|
| CAN0 | CAN1 | | | | |
| 007A60H | 007C60H | DLC Register 0 | DLCR0 | R/W | XXXXXXXXXB |
| 007A61H | 007C61H | | | | |
| 007A62H | 007C62H | DLC Register 1 | DLCR1 | R/W | XXXXXXXXXB |
| 007A63H | 007C63H | | | | |
| 007A64H | 007C64H | DLC Register 2 | DLCR2 | R/W | XXXXXXXXXB |
| 007A65H | 007C65H | | | | |
| 007A66H | 007C66H | DLC Register 3 | DLCR3 | R/W | XXXXXXXXXB |
| 007A67H | 007C67H | | | | |
| 007A68H | 007C68H | DLC Register 4 | DLCR4 | R/W | XXXXXXXXXB |
| 007A69H | 007C69H | | | | |
| 007A6AH | 007C6AH | DLC Register 5 | DLCR5 | R/W | XXXXXXXXXB |
| 007A6BH | 007C6BH | | | | |
| 007A6CH | 007C6CH | DLC Register 6 | DLCR6 | R/W | XXXXXXXXXB |
| 007A6DH | 007C6DH | | | | |
| 007A6EH | 007C6EH | DLC Register 7 | DLCR7 | R/W | XXXXXXXXXB |
| 007A6FH | 007C6FH | | | | |
| 007A70H | 007C70H | DLC Register 8 | DLCR8 | R/W | XXXXXXXXXB |
| 007A71H | 007C71H | | | | |
| 007A72H | 007C72H | DLC Register 9 | DLCR9 | R/W | XXXXXXXXXB |
| 007A73H | 007C73H | | | | |
| 007A74H | 007C74H | DLC Register 10 | DLCR10 | R/W | XXXXXXXXXB |
| 007A75H | 007C75H | | | | |
| 007A76H | 007C76H | DLC Register 11 | DLCR11 | R/W | XXXXXXXXXB |
| 007A77H | 007C77H | | | | |
| 007A78H | 007C78H | DLC Register 12 | DLCR12 | R/W | XXXXXXXXXB |
| 007A79H | 007C79H | | | | |
| 007A7AH | 007C7AH | DLC Register 13 | DLCR13 | R/W | XXXXXXXXXB |
| 007A7BH | 007C7BH | | | | |
| 007A7CH | 007C7CH | DLC Register 14 | DLCR14 | R/W | XXXXXXXXXB |
| 007A7DH | 007C7DH | | | | |
| 007A7EH | 007C7EH | DLC Register 15 | DLCR15 | R/W | XXXXXXXXXB |
| 007A7FH | 007C7FH | | | | |

MB90340E Series

List of Message Buffers (DLC Registers and Data Registers) (2)

| Address | | Register | Abbreviation | Access | Initial Value |
|--------------------------|--------------------------|-------------------------------|--------------|--------|--|
| CAN0 | CAN1 | | | | |
| 007A80H to 007A87H | 007C80H to 007C87H | Data Register 0 (8 bytes) | DTR0 | R/W | XXXXXXXX _B to XXXXXXXX _B |
| 007A88H to 007A8FH | 007C88H to 007C8FH | Data Register 1 (8 bytes) | DTR1 | R/W | XXXXXXXX _B to XXXXXXXX _B |
| 007A90H to 007A97H | 007C90H to 007C97H | Data Register 2 (8 bytes) | DTR2 | R/W | XXXXXXXX _B to XXXXXXXX _B |
| 007A98H to 007A9FH | 007C98H to 007C9FH | Data Register 3 (8 bytes) | DTR3 | R/W | XXXXXXXX _B to XXXXXXXX _B |
| 007AA0H to 007AA7H | 007CA0H to 007CA7H | Data Register 4 (8 bytes) | DTR4 | R/W | XXXXXXXX _B to XXXXXXXX _B |
| 007AA8H to 007AAFH | 007CA8H to 007CAFH | Data Register 5 (8 bytes) | DTR5 | R/W | XXXXXXXX _B to XXXXXXXX _B |
| 007AB0H to 007AB7H | 007CB0H to 007CB7H | Data Register 6 (8 bytes) | DTR6 | R/W | XXXXXXXX _B to XXXXXXXX _B |
| 007AB8H to 007ABFH | 007CB8H to 007CBFH | Data Register 7 (8 bytes) | DTR7 | R/W | XXXXXXXX _B to XXXXXXXX _B |
| 007AC0H to 007AC7H | 007CC0H to 007CC7H | Data Register 8 (8 bytes) | DTR8 | R/W | XXXXXXXX _B to XXXXXXXX _B |
| 007AC8H to 007ACFH | 007CC8H to 007CCFH | Data Register 9 (8 bytes) | DTR9 | R/W | XXXXXXXX _B to XXXXXXXX _B |
| 007AD0H to 007AD7H | 007CD0H to 007CD7H | Data Register 10 (8 bytes) | DTR10 | R/W | XXXXXXXX _B to XXXXXXXX _B |
| 007AD8H to 007ADFH | 007CD8H to 007CDFH | Data Register 11 (8 bytes) | DTR11 | R/W | XXXXXXXX _B to XXXXXXXX _B |
| 007AE0H to 007AE7H | 007CE0H to 007CE7H | Data Register 12 (8 bytes) | DTR12 | R/W | XXXXXXXX _B to XXXXXXXX _B |
| 007AE8H to 007AEFH | 007CE8H to 007CEFH | Data Register 13 (8 bytes) | DTR13 | R/W | XXXXXXXX _B to XXXXXXXX _B |

MB90340E Series

List of Message Buffers (DLC Registers and Data Registers) (3)

| Address | | Register | Abbreviation | Access | Initial Value |
|--|--|-------------------------------|--------------|--------|--|
| CAN0 | CAN1 | | | | |
| 007AF0 _H to 007AF7 _H | 007CF0 _H to 007CF7 _H | Data Register 14 (8 bytes) | DTR14 | R/W | XXXXXXXX _B to XXXXXXXX _B |
| 007AF8 _H to 007AFF _H | 007CF8 _H to 007CFF _H | Data Register 15 (8 bytes) | DTR15 | R/W | XXXXXXXX _B to XXXXXXXX _B |

MB90340E Series

■ INTERRUPT FACTORS, INTERRUPT VECTORS, INTERRUPT CONTROL REGISTER

| Interrupt cause | EI ² OS Support | DMA channel number | Interrupt vector | | Interrupt control register | |
|---------------------------------------|----------------------------|--------------------|------------------|---------------------|----------------------------|---------------------|
| | | | Number | Address | Number | Address |
| Reset | N | — | #08 | FFFFDC _H | — | — |
| INT9 instruction | N | — | #09 | FFFFD8 _H | — | — |
| Exception | N | — | #10 | FFFFD4 _H | — | — |
| CAN 0 RX | N | — | #11 | FFFFD0 _H | ICR00 | 0000B0 _H |
| CAN 0 TX/NS | N | — | #12 | FFFFCC _H | | |
| CAN 1 RX / Input Capture 6 | Y1 | — | #13 | FFFFC8 _H | ICR01 | 0000B1 _H |
| CAN 1 TX/NS / Input Capture 7 | Y1 | — | #14 | FFFFC4 _H | | |
| CAN 2 RX / I ² C0 | N | — | #15 | FFFFC0 _H | ICR02 | 0000B2 _H |
| CAN 2 TX/NS | N | — | #16 | FFFFBC _H | | |
| 16-bit Reload Timer 0 | Y1 | 0 | #17 | FFFFB8 _H | ICR03 | 0000B3 _H |
| 16-bit Reload Timer 1 | Y1 | 1 | #18 | FFFFB4 _H | | |
| 16-bit Reload Timer 2 | Y1 | 2 | #19 | FFFFB0 _H | ICR04 | 0000B4 _H |
| 16-bit Reload Timer 3 | Y1 | — | #20 | FFFFAC _H | | |
| PPG 0/1/4/5 | N | — | #21 | FFFFA8 _H | ICR05 | 0000B5 _H |
| PPG 2/3/6/7 | N | — | #22 | FFFFA4 _H | | |
| PPG 8/9/C/D | N | — | #23 | FFFFA0 _H | ICR06 | 0000B6 _H |
| PPG A/B/E/F | N | — | #24 | FFFF9C _H | | |
| Time Base Timer | N | — | #25 | FFFF98 _H | ICR07 | 0000B7 _H |
| External Interrupt 0 to 3, 8 to 11 | Y1 | 3 | #26 | FFFF94 _H | | |
| Watch Timer | N | — | #27 | FFFF90 _H | ICR08 | 0000B8 _H |
| External Interrupt 4 to 7, 12 to 15 | Y1 | 4 | #28 | FFFF8C _H | | |
| A/D Converter | Y1 | 5 | #29 | FFFF88 _H | ICR09 | 0000B9 _H |
| I/O Timer 0 / I/O Timer 1 | N | — | #30 | FFFF84 _H | | |
| Input Capture 4/5 / I ² C1 | Y1 | 6 | #31 | FFFF80 _H | ICR10 | 0000BA _H |
| Output Compare 0/1/4/5 | Y1 | 7 | #32 | FFFF7C _H | | |
| Input Capture 0 to 3 | Y1 | 8 | #33 | FFFF78 _H | ICR11 | 0000BB _H |
| Output Compare 2/3/6/7 | Y1 | 9 | #34 | FFFF74 _H | | |
| UART 0 RX | Y2 | 10 | #35 | FFFF70 _H | ICR12 | 0000BC _H |
| UART 0 TX | Y1 | 11 | #36 | FFFF6C _H | | |
| UART 1 RX / UART 3 RX | Y2 | 12 | #37 | FFFF68 _H | ICR13 | 0000BD _H |
| UART 1 TX / UART 3 TX | Y1 | 13 | #38 | FFFF64 _H | | |

(Continued)

(Continued)

| Interrupt cause | EI ² OS Support | DMA channel number | Interrupt vector | | Interrupt control register | |
|-----------------------|----------------------------|--------------------|------------------|---------|----------------------------|---------|
| | | | Number | Address | Number | Address |
| UART 2 RX / UART 4 RX | Y2 | 14 | #39 | FFFF60H | ICR14 | 0000BEH |
| UART 2 TX / UART 4 TX | Y1 | 15 | #40 | FFFF5CH | | |
| Flash Memory | N | — | #41 | FFFF58H | ICR15 | 0000BFH |
| Delayed Interrupt | N | — | #42 | FFFF54H | | |

Y1 : Usable

Y2 : Usable, with EI²OS stop function

N : Unusable

- Notes :
- The peripheral resources sharing the ICR register have the same interrupt level.
 - When two peripheral resources share the ICR register, only one can use Extended Intelligent I/O Service at a time.
 - When either of the two peripheral resources sharing the ICR register specifies Extended Intelligent I/O Service, the other one cannot use interrupts.

MB90340E Series

■ ELECTRICAL CHARACTERISTICS

1. Absolute Maximum Ratings

| Parameter | Symbol | Rating | | Unit | Remarks |
|--|----------------------|----------------|----------------|------|---|
| | | Min | Max | | |
| Power supply voltage*1 | V_{CC} | $V_{SS} - 0.3$ | $V_{SS} + 6.0$ | V | |
| | AV_{CC} | $V_{SS} - 0.3$ | $V_{SS} + 6.0$ | V | $V_{CC} = AV_{CC}$ *2 |
| | AVRH, AVRL | $V_{SS} - 0.3$ | $V_{SS} + 6.0$ | V | $AV_{CC} \geq AVRH$, $AV_{CC} \geq AVRL$, $AVRH \geq AVRL$ |
| Input voltage*1 | V_I | $V_{SS} - 0.3$ | $V_{SS} + 6.0$ | V | *3 |
| Output voltage*1 | V_O | $V_{SS} - 0.3$ | $V_{SS} + 6.0$ | V | *3 |
| Maximum Clamp Current | I_{CLAMP} | -4.0 | +4.0 | mA | *5 |
| Total Maximum Clamp Current | $\Sigma I_{CLAMP} $ | — | 40 | mA | *5 |
| “L” level maximum output current | I_{OL} | — | 15 | mA | *4 |
| “L” level average output current | I_{OLAV} | — | 4 | mA | *4 |
| “L” level maximum overall output current | ΣI_{OL} | — | 100 | mA | *4 |
| “L” level average overall output current | ΣI_{OLAV} | — | 50 | mA | *4 |
| “H” level maximum output current | I_{OH} | — | -15 | mA | *4 |
| “H” level average output current | I_{OHAV} | — | -4 | mA | *4 |
| “H” level maximum overall output current | ΣI_{OH} | — | -100 | mA | *4 |
| “H” level average overall output current | ΣI_{OHAV} | — | -50 | mA | *4 |
| Power consumption | P_D | — | 340 | mW | MB90F347E |
| Operating temperature | T_A | -40 | +105 | °C | |
| Storage temperature | T_{STG} | -55 | +150 | °C | |

*1: This parameter is based on $V_{SS} = AV_{SS} = 0$ V

*2: Set AV_{CC} and V_{CC} to the same voltage. Make sure that AV_{CC} does not exceed V_{CC} and that the voltage at the analog inputs does not exceed AV_{CC} when the power is switched on.

*3: V_I and V_O should not exceed $V_{CC} + 0.3$ V. V_I should not exceed the specified ratings. However if the maximum current to/from an input is limited by some means with external components, the I_{CLAMP} rating supersedes the V_I rating.

*4: Applicable to pins: P00 to P07, P10 to P17, P20 to P27, P30 to P37, P40 to P47, P50 to P57, P60 to P67, P70 to P77, P80 to P87, P90 to P97, PA0, PA1

*5: • Applicable to pins: P00 to P07, P10 to P17, P20 to P27, P30 to P37, P40 to P47, P50 to P57 (Evaluation device : P50 to P55) , P60 to P67, P70 to P77, P80 to P87, P90 to P97, PA0 to PA1

- Use within recommended operating conditions.
- Use with DC voltage (current)
- The +B signal should always be applied by using a limiting resistance placed between the +B signal and the microcontroller.
- The value of the limiting resistance should be set so that when the +B signal is applied, the input current to the microcontroller pin does not exceed the rated value, either instantaneously or for prolonged periods.
- Note that when the microcontroller drive current is low, such as in the power saving modes, the +B input potential may pass through the protective diode and increase the potential at the V_{CC} pin, and this may affect other devices.

(Continued)

(Continued)

- Note that if a +B signal is input when the microcontroller power supply is off (not fixed at 0 V) , the power supply is provided from the pins, so that incomplete operation may result.
- Note that if the +B input is applied during power-on, the power supply is provided from the pins and the resulting supply voltage may not be sufficient to operate the power-on reset.
- Care must be taken not to leave the +B input pin open.
- Sample recommended circuits:

- Input/output equivalent circuits

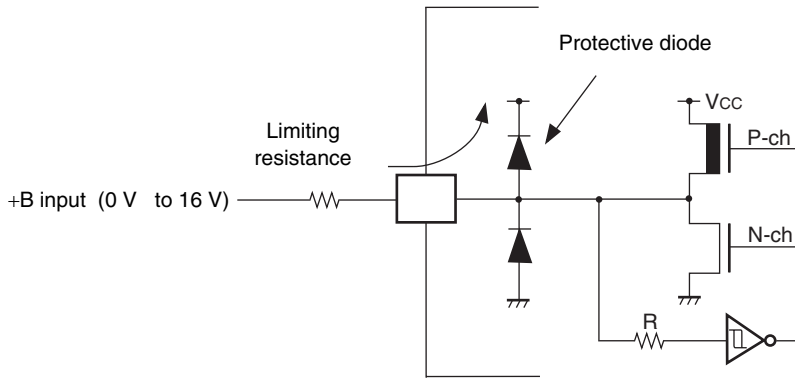

WARNING: Semiconductor devices can be permanently damaged by application of stress (voltage, current, temperature, etc.) in excess of absolute maximum ratings. Do not exceed these ratings.

MB90340E Series

2. Recommended Operating Conditions

($V_{SS} = AV_{SS} = 0\text{ V}$)

| Parameter | Symbol | Value | | | Unit | Remarks |
|-----------------------|-------------------|-------|-----|------|--------------------|---|
| | | Min | Typ | Max | | |
| Power supply voltage | V_{CC}, AV_{CC} | 4.0 | 5.0 | 5.5 | V | Under normal operation |
| | | 3.5 | 5.0 | 5.5 | V | Under normal operation, when not using the A/D converter and not Flash programming. |
| | | 4.5 | 5.0 | 5.5 | V | When External bus is used. |
| | | 3.0 | — | 5.5 | V | Maintains RAM data in stop mode |
| Smoothing capacitor | C_S | 0.1 | — | 1.0 | μF | Use a ceramic capacitor or capacitor of better AC characteristics. Capacitor at the V_{CC} should be greater than this capacitor. |
| Operating temperature | T_A | -40 | — | +105 | $^{\circ}\text{C}$ | |

C Pin Connection Diagram

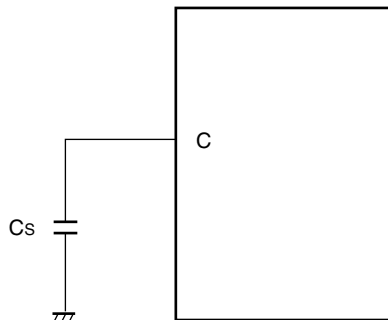

WARNING: The recommended operating conditions are required in order to ensure the normal operation of the semiconductor device. All of the device's electrical characteristics are warranted when the device is operated within these ranges.

Always use semiconductor devices within their recommended operating condition ranges. Operation outside these ranges may adversely affect reliability and could result in device failure.

No warranty is made with respect to uses, operating conditions, or combinations not represented on the data sheet. Users considering application outside the listed conditions are advised to contact their representatives beforehand.

MB90340E Series

3. DC Characteristics

($T_A = -40\text{ }^\circ\text{C}$ to $+105\text{ }^\circ\text{C}$, $V_{CC} = 5.0\text{ V} \pm 10\%$, $f_{CP} \leq 24\text{ MHz}$, $V_{SS} = AV_{SS} = 0\text{ V}$)

| Parameter | Symbol | Pin | Condition | Value | | | Unit | Remarks |
|---|-----------|----------------------------------|--|----------------|-----|----------------|------|--|
| | | | | Min | Typ | Max | | |
| Input H voltage (At $V_{CC} = 5\text{ V} \pm 10\%$) | V_{IHS} | — | — | $0.8 V_{CC}$ | — | $V_{CC} + 0.3$ | V | Port inputs if CMOS hysteresis input levels are selected (except P12, P44, P45, P46, P47, P50, P82, P83) |
| | V_{IHA} | — | — | $0.8 V_{CC}$ | — | $V_{CC} + 0.3$ | V | Port inputs if Automotive input levels are selected |
| | V_{IHT} | — | — | 2.0 | — | $V_{CC} + 0.3$ | V | Port inputs if TTL input levels are selected |
| | V_{IHS} | — | — | $0.7 V_{CC}$ | — | $V_{CC} + 0.3$ | V | P12, P50, P82, P85 inputs if CMOS input levels are selected |
| | V_{IHI} | — | — | $0.7 V_{CC}$ | — | $V_{CC} + 0.3$ | V | P44, P45, P46, P47 inputs if CMOS hysteresis input levels are selected |
| | V_{IHR} | — | — | $0.8 V_{CC}$ | — | $V_{CC} + 0.3$ | V | \overline{RST} input pin (CMOS hysteresis) |
| | V_{IHM} | — | — | $V_{CC} - 0.3$ | — | $V_{CC} + 0.3$ | V | MD input pin |
| Input L voltage (At $V_{CC} = 5\text{ V} \pm 10\%$) | V_{ILS} | — | — | $V_{SS} - 0.3$ | — | $0.2 V_{CC}$ | V | Port inputs if CMOS hysteresis input levels are selected (except P12, P44, P45, P46, P47, P50, P82, P83) |
| | V_{ILA} | — | — | $V_{SS} - 0.3$ | — | $0.5 V_{CC}$ | V | Port inputs if Automotive input levels are selected |
| | V_{ILT} | — | — | $V_{SS} - 0.3$ | — | 0.8 | V | Port inputs if TTL input levels are selected |
| | V_{ILS} | — | — | $V_{SS} - 0.3$ | — | $0.3 V_{CC}$ | V | P12, P50, P82, P85 inputs if CMOS input levels are selected |
| | V_{ILI} | — | — | $V_{SS} - 0.3$ | — | $0.3 V_{CC}$ | V | P44, P45, P46, P47 inputs if CMOS hysteresis input levels are selected |
| | V_{ILR} | — | — | $V_{SS} - 0.3$ | — | $0.2 V_{CC}$ | V | \overline{RST} input pin (CMOS hysteresis) |
| | V_{ILM} | — | — | $V_{SS} - 0.3$ | — | $V_{SS} + 0.3$ | V | MD input pin |
| Output H voltage | V_{OH} | Normal outputs | $V_{CC} = 4.5\text{ V}$, $I_{OH} = -4.0\text{ mA}$ | $V_{CC} - 0.5$ | — | — | V | |
| Output H voltage | V_{OHI} | I ² C current outputs | $V_{CC} = 4.5\text{ V}$, $I_{OH} = -3.0\text{ mA}$ | $V_{CC} - 0.5$ | — | — | V | |
| Output L voltage | V_{OL} | Normal outputs | $V_{CC} = 4.5\text{ V}$, $I_{OL} = 4.0\text{ mA}$ | — | — | 0.4 | V | |
| Output L voltage | V_{OLI} | I ² C current outputs | $V_{CC} = 4.5\text{ V}$, $I_{OL} = 3.0\text{ mA}$ | — | — | 0.4 | V | |

(Continued)

MB90340E Series

(Continued)

($T_A = -40\text{ }^\circ\text{C}$ to $+105\text{ }^\circ\text{C}$, $V_{CC} = 5.0\text{ V} \pm 10\%$, $f_{CP} \leq 24\text{ MHz}$, $V_{SS} = AV_{SS} = 0\text{ V}$)

| Parameter | Symbol | Pin | Condition | Value | | | Unit | Remarks |
|-----------------------|---------------|--|---|-------|-----|-------------|------------------|-----------------------------|
| | | | | Min | Typ | Max | | |
| Input leak current | I_{IL} | — | $V_{CC} = 5.5\text{ V}$, $V_{SS} < V_I < V_{CC}$ | -1 | — | +1 | μA | |
| Pull-up resistance | R_{UP} | P00 to P07, P10 to P17, P20 to P27, P30 to P37, RST | — | 25 | 50 | 100 | $\text{k}\Omega$ | |
| Pull-down resistance | R_{DOWN} | MD2 | — | 25 | 50 | 100 | $\text{k}\Omega$ | Except Flash memory devices |
| Power supply current* | I_{CC} | V_{CC} | $V_{CC} = 5.0\text{ V}$, Internal frequency : 24 MHz, At normal operation. | — | 55 | 70 | mA | |
| | | | $V_{CC} = 5.0\text{ V}$, Internal frequency : 24 MHz, At writing Flash memory. | — | 70 | 85 | mA | Flash memory devices |
| | | | $V_{CC} = 5.0\text{ V}$, Internal frequency : 24 MHz, At erasing Flash memory. | — | 75 | 90 | mA | Flash memory devices |
| | I_{CCS} | | $V_{CC} = 5.0\text{ V}$, Internal frequency : 24 MHz, In Sleep mode. | — | 25 | 35 | mA | |
| | I_{CTS} | | $V_{CC} = 5.0\text{ V}$, Internal frequency : 2 MHz, In Main Timer mode | — | 0.3 | 0.8 | mA | |
| | $I_{CTSPLL6}$ | | $V_{CC} = 5.0\text{ V}$, Internal frequency : 24 MHz, In PLL Timer mode, external frequency = 4 MHz | — | 4 | 7 | mA | |
| | I_{CCL} | | $V_{CC} = 5.0\text{ V}$ Internal frequency : 8 kHz, In sub operation $T_A = +25\text{ }^\circ\text{C}$ | — | 70 | 140 | μA | |
| | I_{CCLS} | | $V_{CC} = 5.0\text{ V}$ Internal frequency : 8 kHz, In sub sleep $T_A = +25\text{ }^\circ\text{C}$ | — | 20 | 50 | μA | |
| | I_{CCT} | | $V_{CC} = 5.0\text{ V}$ Internal frequency : 8 kHz, In watch mode $T_A = +25\text{ }^\circ\text{C}$ | — | 10 | 35 | μA | |
| | I_{CCH} | | $V_{CC} = 5.0\text{ V}$, In Stop mode, $T_A = +25\text{ }^\circ\text{C}$ | — | 7 | 25 | μA | |
| Input capacitance | C_{IN} | Other than C, AV_{CC} , AV_{SS} , $AVRH$, $AVRL$, V_{CC} , V_{SS} | — | 5 | 15 | pF | | |

* : The power supply current is measured with an external clock.

4. AC Characteristics

(1) Clock Timing

($T_A = -40\text{ }^\circ\text{C}$ to $+105\text{ }^\circ\text{C}$, $V_{CC} = 5.0\text{ V} \pm 10\%$, $f_{CP} \leq 24\text{ MHz}$, $V_{SS} = AV_{SS} = 0\text{ V}$)

| Parameter | Symbol | Pin | Value | | | Unit | Remarks |
|---|--------------------|----------|-------|--------|-----|---------------|-----------------------------------|
| | | | Min | Typ | Max | | |
| Clock frequency | f_c | X0, X1 | 3 | — | 16 | MHz | When using an oscillation circuit |
| | | X0, X1 | 3 | — | 24 | MHz | When using an external clock* |
| | f_{CL} | X0A, X1A | — | 32.768 | 100 | kHz | |
| Clock cycle time | t_{CYL} | X0, X1 | 62.5 | — | 333 | ns | When using an oscillation circuit |
| | | X0, X1 | 41.67 | — | 333 | ns | When using an external clock |
| | t_{CYLL} | X0A, X1A | 10 | 30.5 | — | μs | |
| Input clock pulse width | P_{WH}, P_{WL} | X0 | 10 | — | — | ns | Duty ratio is about 30% to 70%. |
| | P_{WHL}, P_{WLL} | X0A | 5 | 15.2 | — | μs | |
| Input clock rise and fall time | t_{CR}, t_{CF} | X0 | — | — | 5 | ns | When using external clock |
| Internal operating clock frequency (machine clock) | f_{CP} | — | 1.5 | — | 24 | MHz | When using main clock |
| | f_{CPL} | — | — | 8.192 | 50 | kHz | When using sub clock |
| Internal operating clock cycle time (machine clock) | t_{CP} | — | 41.67 | — | 666 | ns | When using main clock |
| | t_{CPL} | — | 20 | 122.1 | — | μs | When using sub clock |

* : When selecting the PLL clock, the range of clock frequency is limited. Use this product within the range as mentioned in "Relation between the external clock frequency and machine clock frequency".

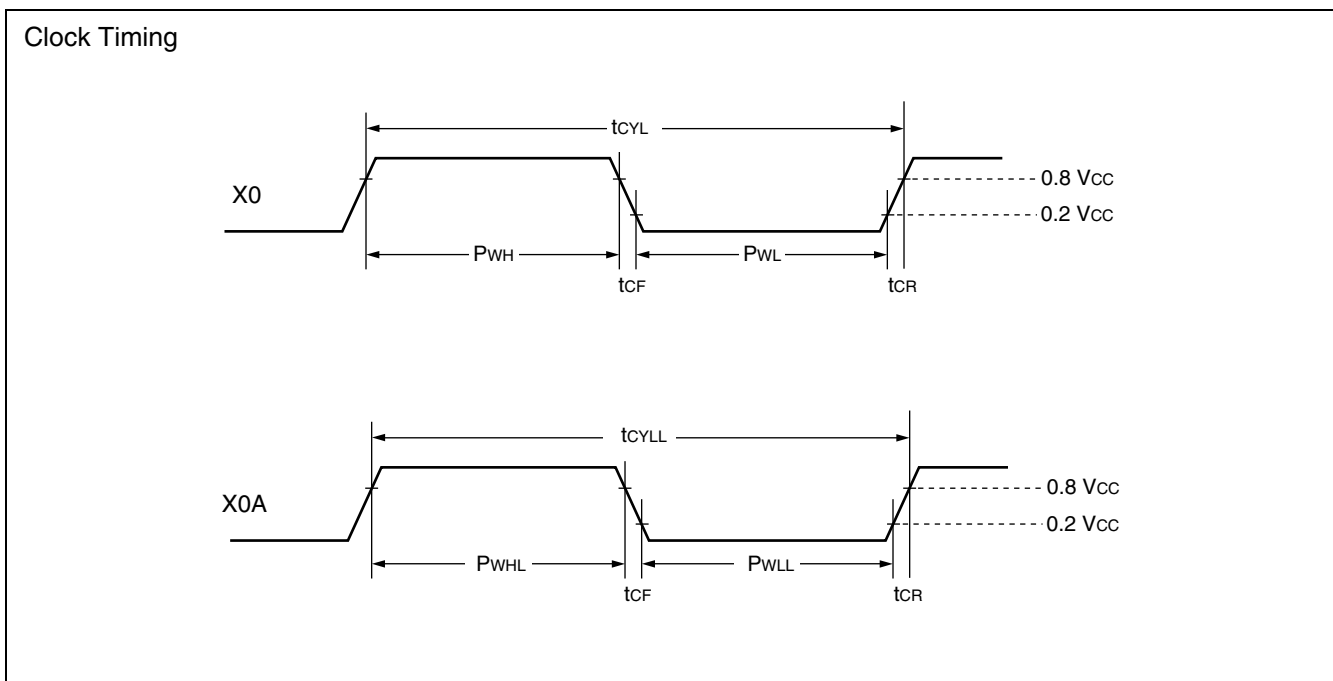

MB90340E Series

Guaranteed PLL operation range

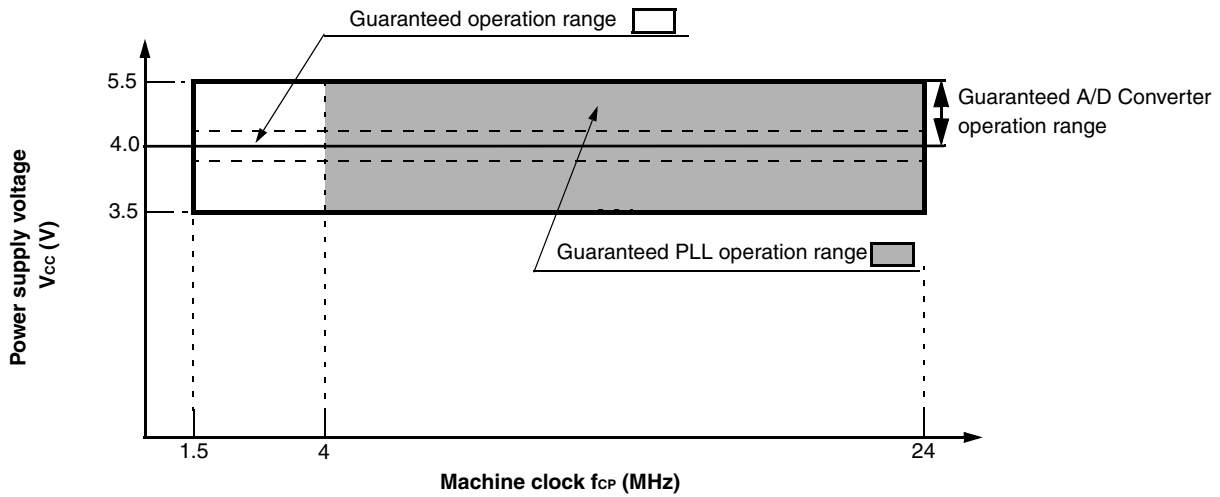

Guaranteed operation range of MB90340E series

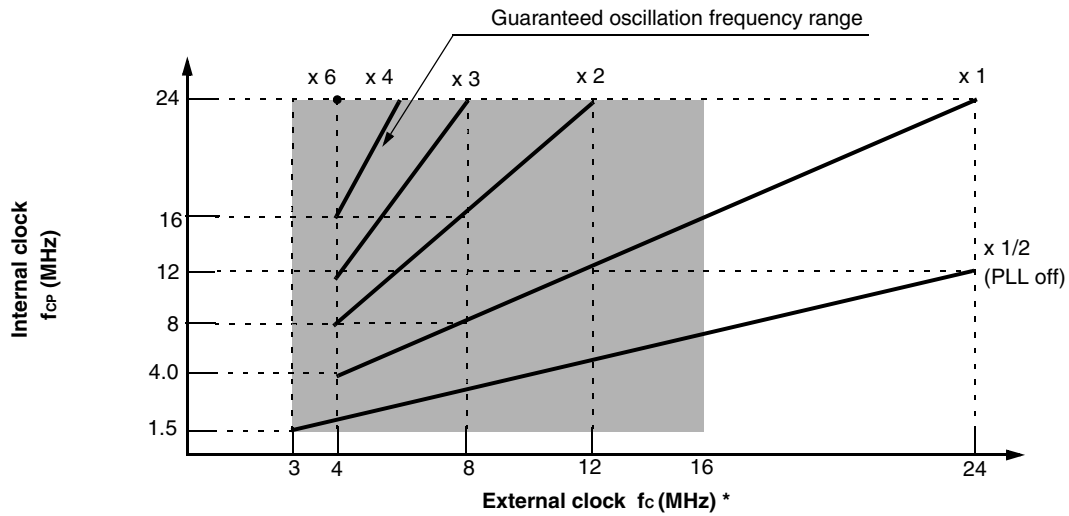

* : When using a crystal oscillator or ceramic oscillator, the maximum oscillation clock frequency is 16 MHz

(2) Reset Standby Input

($T_A = -40\text{ }^\circ\text{C}$ to $+105\text{ }^\circ\text{C}$, $V_{CC} = 5.0\text{ V} \pm 10\%$, $f_{CP} \leq 24\text{ MHz}$, $V_{SS} = AV_{SS} = 0.0\text{ V}$)

| Parameter | Symbol | Pin | Value | | Unit | Remarks |
|------------------|------------|------------------|--|-----|---------------|---|
| | | | Min | Max | | |
| Reset input time | t_{RSTL} | \overline{RST} | 500 | — | ns | Under normal operation |
| | | | Oscillation time of oscillator* + 100 μs | | ns | In Stop mode, Sub Clock mode, Sub Sleep mode and Watch mode |
| | | | 100 | — | μs | In Time Timer mode |

* : The oscillation time of the oscillator is the time it takes for the amplitude of the oscillations to reach 90%. For crystal oscillators, this time is between several ms and several tens of ms, for ceramic oscillators the time is between several hundred μs and several ms, and for an external clock, the time is 0 ms.

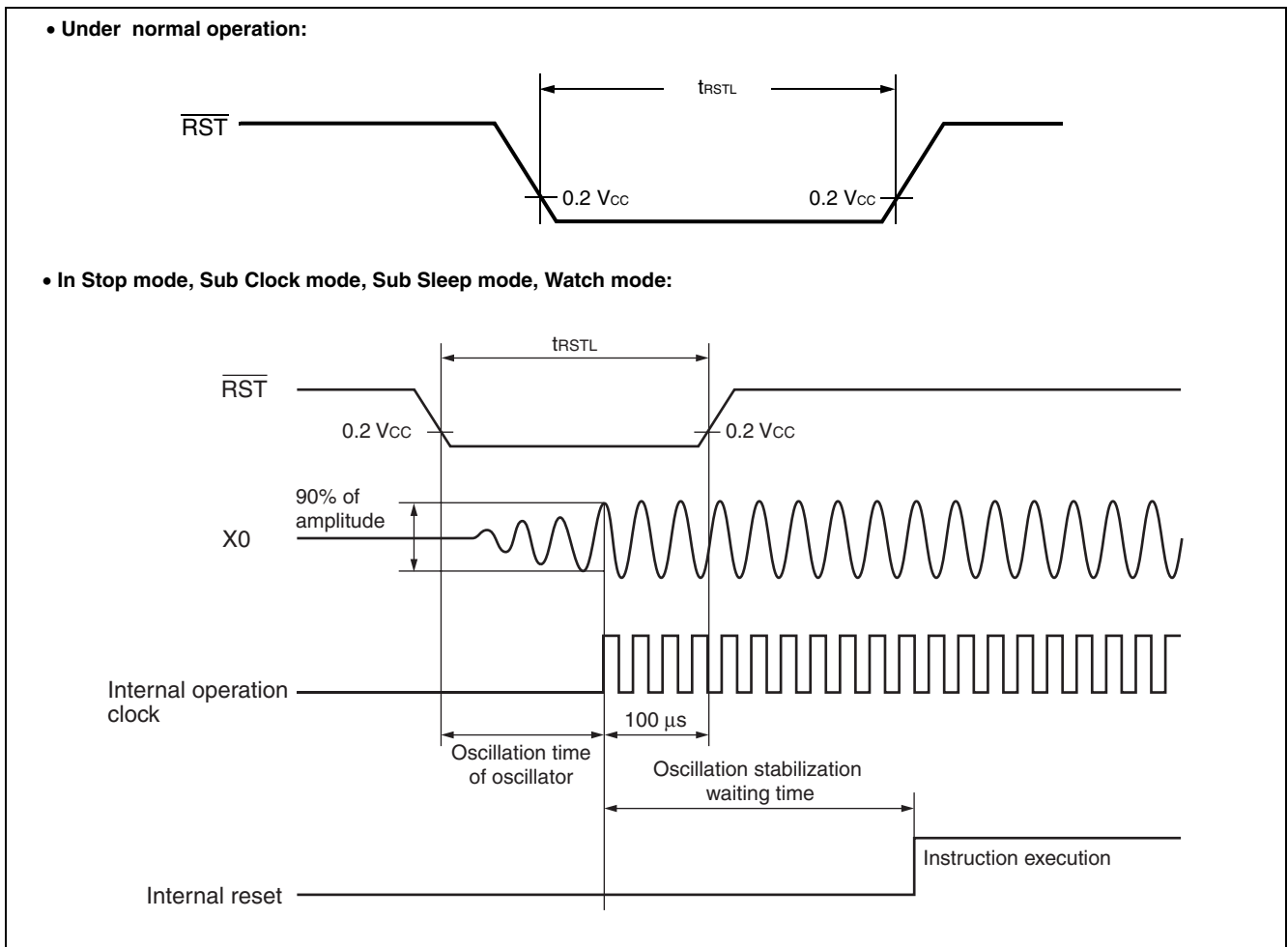

MB90340E Series

(3) Power On Reset

($T_A = -40\text{ }^\circ\text{C}$ to $+105\text{ }^\circ\text{C}$, $V_{CC} = 5.0\text{ V} \pm 10\%$, $f_{CP} \leq 24\text{ MHz}$, $V_{SS} = AV_{SS} = 0.0\text{ V}$)

| Parameter | Symbol | Pin | Condition | Value | | Unit | Remarks |
|--------------------|-----------|----------|-----------|-------|-----|------|-----------------------------|
| | | | | Min | Max | | |
| Power on rise time | t_R | V_{CC} | — | 0.05 | 30 | ms | |
| Power off time | t_{OFF} | V_{CC} | — | 1 | — | ms | Due to repetitive operation |

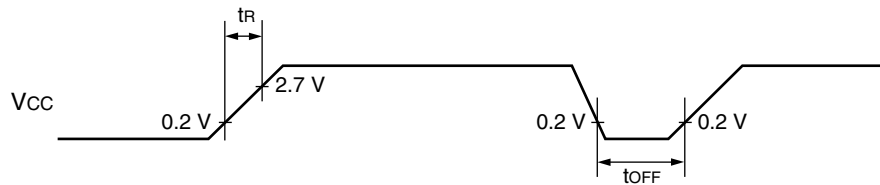

If you change the power supply voltage too rapidly, a power on reset may occur. We recommend that you startup smoothly by restraining voltages when changing the power supply voltage during operation, as shown in the figure below. Perform while not using the PLL clock. However, if voltage drops are within 1 V/s, you can operate while using the PLL clock.

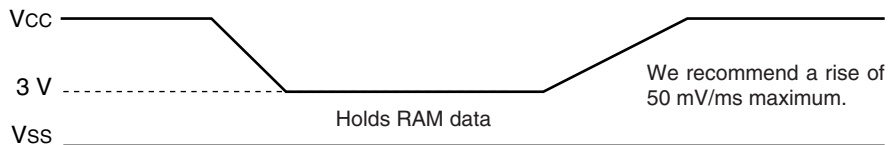

(4) Clock Output Timing

($T_A = -40\text{ }^\circ\text{C}$ to $+105\text{ }^\circ\text{C}$, $V_{CC} = 5.0\text{ V} \pm 10\%$, $V_{SS} = 0.0\text{ V}$, $f_{CP} \leq 24\text{ MHz}$)

| Parameter | Symbol | Pin | Condition | Value | | Unit | Remarks |
|---|------------|-----|-----------|-------|-----|------|--------------------------|
| | | | | Min | Max | | |
| Cycle time | t_{CYC} | CLK | — | 62.5 | — | ns | $f_{CP} = 16\text{ MHz}$ |
| | | | | 41.76 | — | ns | $f_{CP} = 24\text{ MHz}$ |
| CLK $\uparrow \rightarrow$ CLK \downarrow | t_{CHCL} | CLK | — | 20 | — | ns | $f_{CP} = 16\text{ MHz}$ |
| | | | | 13 | — | ns | $f_{CP} = 24\text{ MHz}$ |

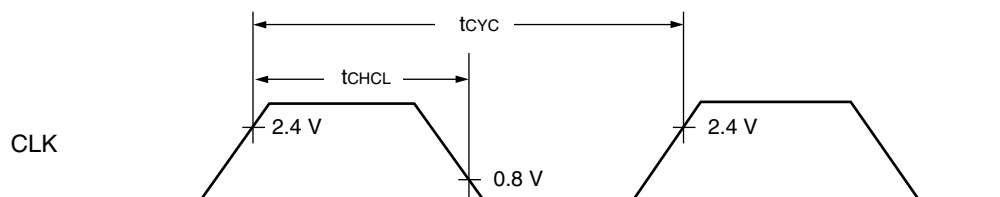

(5) Bus Timing (Read)

($T_A = -40\text{ }^\circ\text{C}$ to $+105\text{ }^\circ\text{C}$, $V_{CC} = 5.0\text{ V} \pm 10\%$, $V_{SS} = 0.0\text{ V}$, $f_{CP} \leq 24\text{ MHz}$)

| Parameter | Symbol | Pin | Condition | Value | | Unit |
|--|------------|---|-----------|-------------------|-------------------|------|
| | | | | Min | Max | |
| ALE pulse width | t_{LHLL} | ALE | — | $t_{CP}/2 - 10$ | — | ns |
| Valid address → ALE ↓ time | t_{AVLL} | ALE, A23 to A16, AD15 to AD00 | | $t_{CP}/2 - 20$ | — | ns |
| ALE ↓ → Address valid time | t_{LLAX} | ALE, AD15 to AD00 | | $t_{CP}/2 - 15$ | — | ns |
| Valid address → \overline{RD} ↓ time | t_{AVRL} | A23 to A16, AD15 to AD00, \overline{RD} | | $t_{CP} - 15$ | — | ns |
| Valid address → Valid data input | t_{AVDV} | A23 to A16, AD15 to AD00 | | — | $5 t_{CP}/2 - 60$ | ns |
| \overline{RD} pulse width | t_{RLRH} | \overline{RD} | | $3 t_{CP}/2 - 20$ | — | ns |
| \overline{RD} ↓ → Valid data input | t_{RLDV} | \overline{RD} , AD15 to AD00 | | — | $3 t_{CP}/2 - 50$ | ns |
| \overline{RD} ↑ → Data hold time | t_{RHDX} | \overline{RD} , AD15 to AD00 | | 0 | — | ns |
| \overline{RD} ↓ → ALE ↑ time | t_{RHLH} | \overline{RD} , ALE | | $t_{CP}/2 - 15$ | — | ns |
| \overline{RD} ↑ → Address valid time | t_{RHAX} | \overline{RD} , A23 to A16 | | $t_{CP}/2 - 10$ | — | ns |
| Valid address → CLK ↑ time | t_{AVCH} | A23 to A16, AD15 to AD00, CLK | | $t_{CP}/2 - 16$ | — | ns |
| \overline{RD} ↓ → CLK ↑ time | t_{RLCH} | \overline{RD} , CLK | | $t_{CP}/2 - 15$ | — | ns |
| ALE ↓ → \overline{RD} ↓ time | t_{LLRL} | ALE, \overline{RD} | | $t_{CP}/2 - 15$ | — | ns |

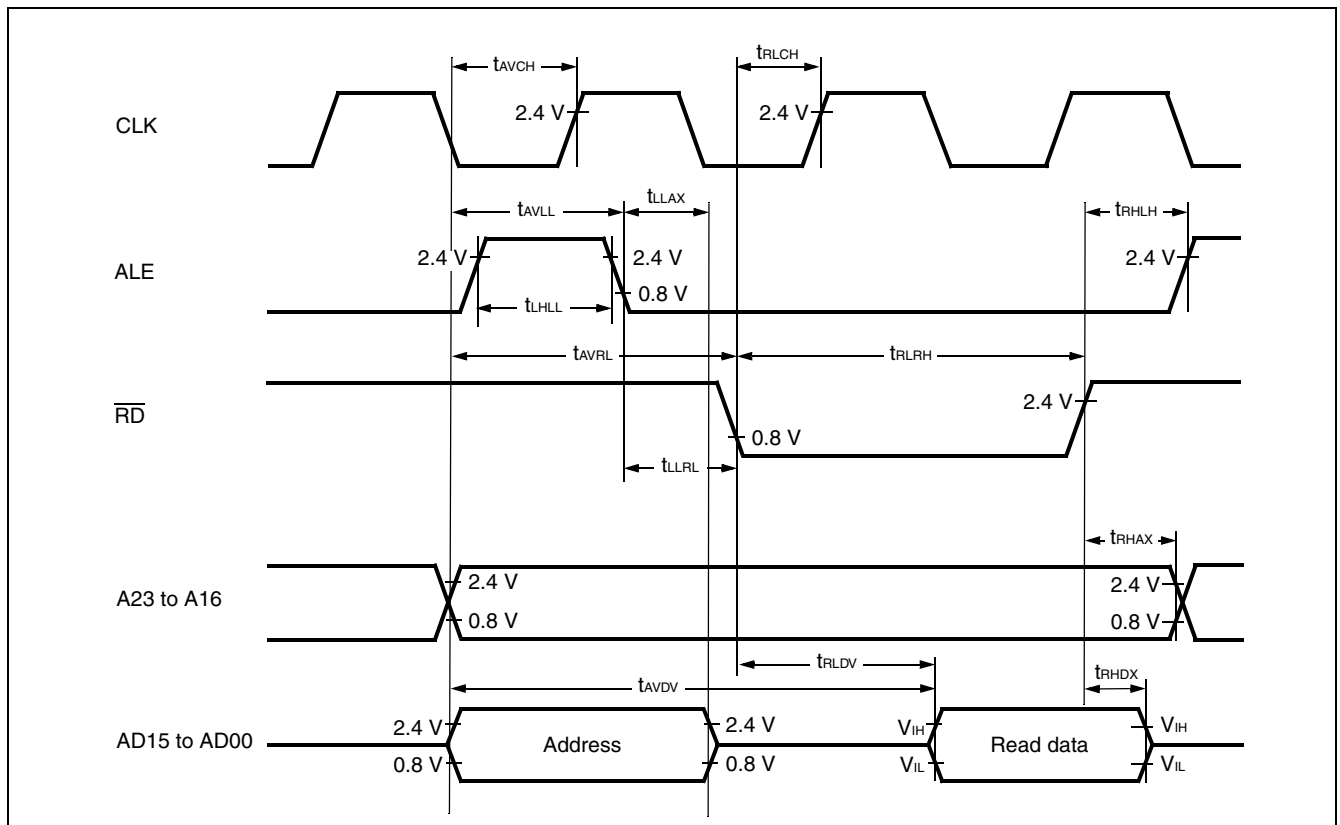

MB90340E Series

(6) Bus Timing (Write)

($T_A = -40\text{ }^\circ\text{C}$ to $+105\text{ }^\circ\text{C}$, $V_{CC} = 5.0\text{ V} \pm 10\%$, $V_{SS} = 0.0\text{ V}$, $f_{CP} \leq 24\text{ MHz}$)

| Parameter | Symbol | Pin | Condition | Value | | Unit |
|---|------------|---|-----------|---------------------|-----|------|
| | | | | Min | Max | |
| Valid address $\rightarrow \overline{WR} \downarrow$ time | t_{AVWL} | A23 to A16, AD15 to AD00, \overline{WR} | — | $t_{CP} - 15$ | — | ns |
| \overline{WR} pulse width | t_{WLWH} | \overline{WR} | | $3 t_{CP} / 2 - 20$ | — | ns |
| Valid data output $\rightarrow \overline{WR} \uparrow$ time | t_{DVWH} | AD15 to AD00, \overline{WR} | | $3 t_{CP} / 2 - 20$ | — | ns |
| $\overline{WR} \uparrow \rightarrow$ Data hold time | t_{WHDX} | AD15 to AD00, \overline{WR} | | 15 | — | ns |
| $\overline{WR} \uparrow \rightarrow$ Address valid time | t_{WHAX} | A23 to A16, \overline{WR} | | $t_{CP} / 2 - 10$ | — | ns |
| $\overline{WR} \uparrow \rightarrow$ ALE \uparrow time | t_{WHLH} | \overline{WR} , ALE | | $t_{CP} / 2 - 15$ | — | ns |
| $\overline{WR} \downarrow \rightarrow$ CLK \uparrow time | t_{WLCH} | \overline{WR} , CLK | | $t_{CP} / 2 - 15$ | — | ns |

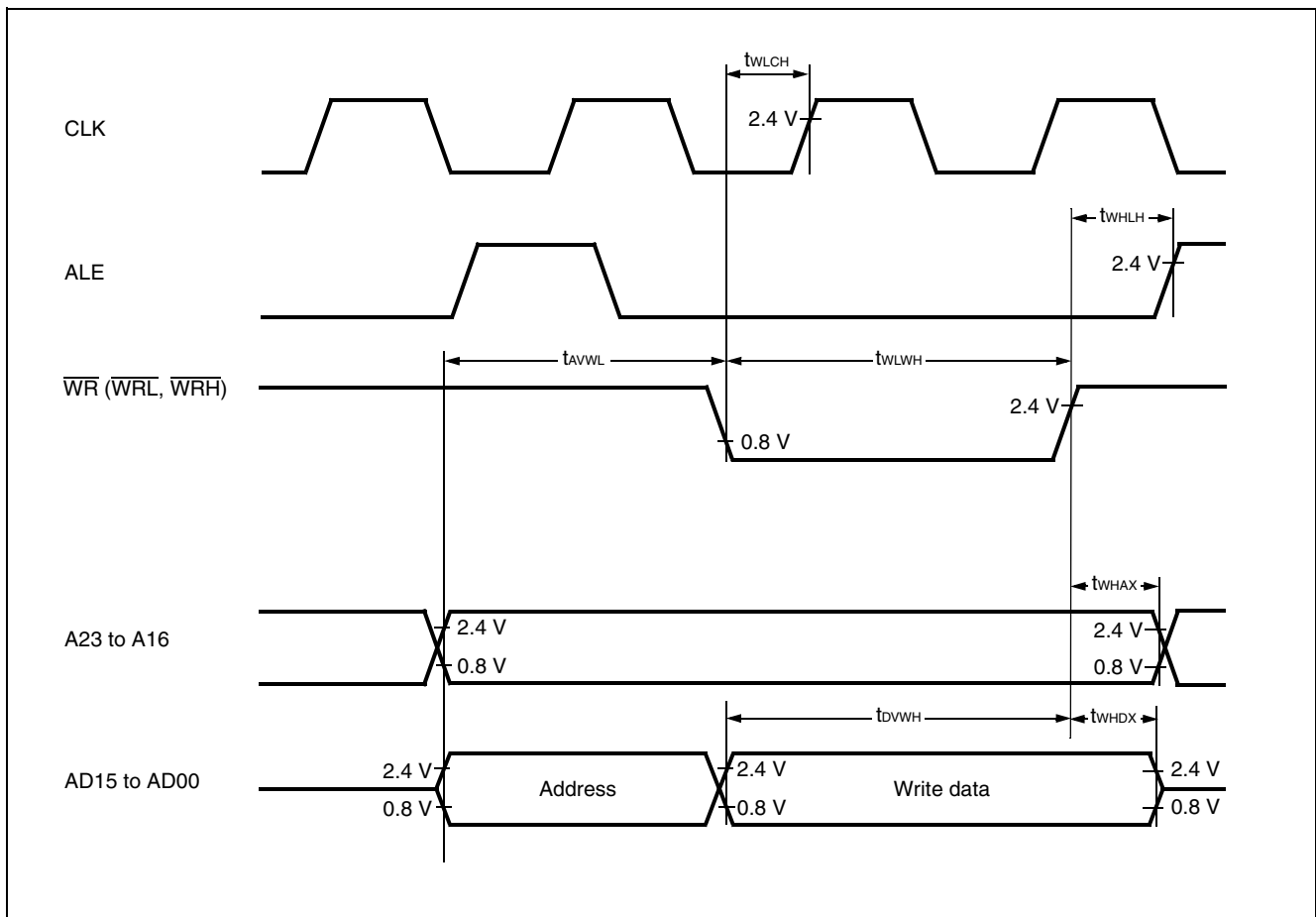

(7) Ready Input Timing

($T_A = -40\text{ }^\circ\text{C}$ to $+105\text{ }^\circ\text{C}$, $V_{CC} = 5.0\text{ V} \pm 10\%$, $V_{SS} = 0.0\text{ V}$, $f_{CP} \leq 24\text{ MHz}$)

| Parameter | Symbol | Pin | Test Condition | Rated Value | | Unit | Remarks |
|----------------|------------|-----|----------------|-------------|-----|------|--------------------------|
| | | | | Min | Max | | |
| RDY setup time | t_{RYHS} | RDY | — | 45 | — | ns | $f_{CP} = 16\text{ MHz}$ |
| | | | | 32 | — | ns | $f_{CP} = 24\text{ MHz}$ |
| RDY hold time | t_{RYHH} | RDY | | 0 | — | ns | |

Note : If the RDY setup time is insufficient, use the auto-ready function.

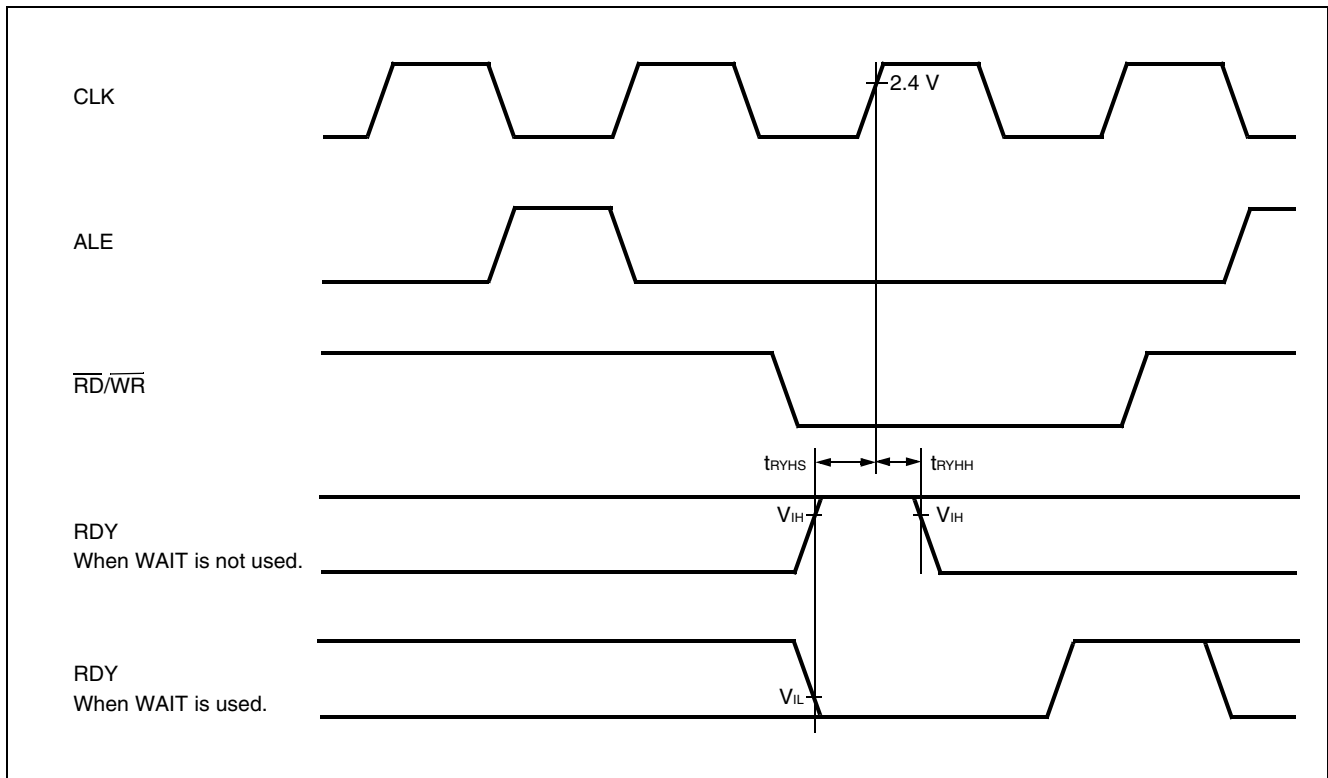

MB90340E Series

(8) Hold Timing

($T_A = -40\text{ }^\circ\text{C}$ to $+105\text{ }^\circ\text{C}$, $V_{CC} = 5.0\text{ V} \pm 10\%$, $V_{SS} = 0.0\text{ V}$, $f_{CP} \leq 24\text{ MHz}$)

| Parameter | Symbol | Pin | Condition | Value | | Unit |
|--|------------|-------------------------|-----------|----------|------------|------|
| | | | | Min | Max | |
| Pin floating $\rightarrow \overline{\text{HAK}} \downarrow$ time | t_{XHAL} | $\overline{\text{HAK}}$ | — | 30 | t_{CP} | ns |
| $\overline{\text{HAK}} \uparrow$ time \rightarrow Pin valid time | t_{HAHV} | $\overline{\text{HAK}}$ | | t_{CP} | $2 t_{CP}$ | ns |

Note : There is more than 1 cycle from when HRQ reads in until the $\overline{\text{HAK}}$ is changed.

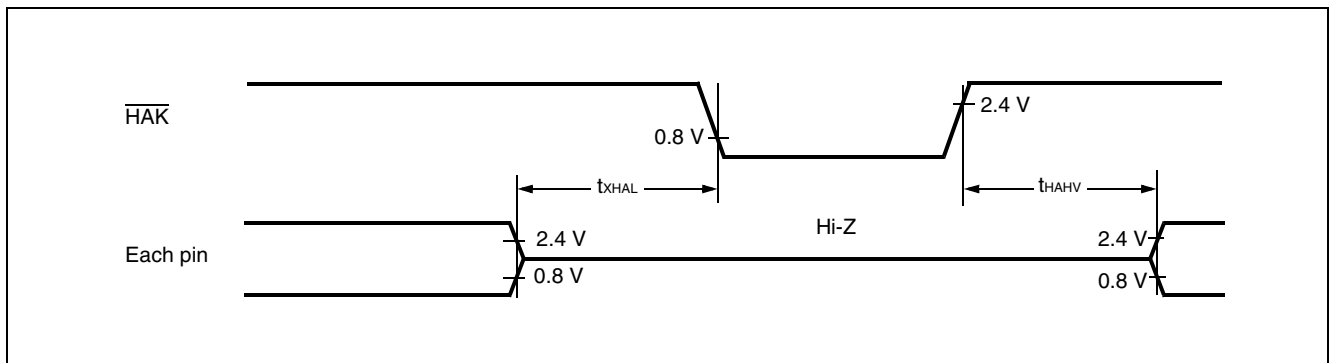

(9) UART0/1/2/3/4

($T_A = -40\text{ }^\circ\text{C}$ to $+105\text{ }^\circ\text{C}$, $V_{CC} = 5.0\text{ V} \pm 10\%$, $V_{SS} = 0.0\text{ V}$, $f_{CP} \leq 24\text{ MHz}$)

| Parameter | Symbol | Pin | Condition | Value | | Unit |
|------------------------------|------------|----------------------------|--|------------|------|------|
| | | | | Min | Max | |
| Serial clock cycle time | t_{SCYC} | SCK0 to SCK4 | Internal clock operation output pins are $C_L = 80\text{ pF} + 1\text{ TTL}$ | $8 t_{CP}$ | — | ns |
| SCK ↓ → SOT delay time | t_{SLOV} | SCK0 to SCK4, SOT0 to SOT4 | | - 80 | + 80 | ns |
| Valid SIN → SCK ↑ | t_{VSH} | SCK0 to SCK4, SIN0 to SIN4 | | 100 | — | ns |
| SCK ↑ → Valid SIN hold time | t_{SHIX} | SCK0 to SCK4, SIN0 to SIN4 | | 60 | — | ns |
| Serial clock "H" pulse width | t_{SHSL} | SCK0 to SCK4 | External clock operation output pins are $C_L = 80\text{ pF} + 1\text{ TTL}$ | $4 t_{CP}$ | — | ns |
| Serial clock "L" pulse width | t_{SLSH} | SCK0 to SCK4 | | $4 t_{CP}$ | — | ns |
| SCK ↓ → SOT delay time | t_{SLOV} | SCK0 to SCK4, SOT0 to SOT4 | | — | 150 | ns |
| Valid SIN → SCK ↑ | t_{VSH} | SCK0 to SCK4, SIN0 to SIN4 | | 60 | — | ns |
| SCK ↑ → Valid SIN hold time | t_{SHIX} | SCK0 to SCK4, SIN0 to SIN4 | 60 | — | ns | |

- Notes :
- AC characteristic CLK synchronized mode.
 - CL is the value of the load capacitance applied to the pins during testing.

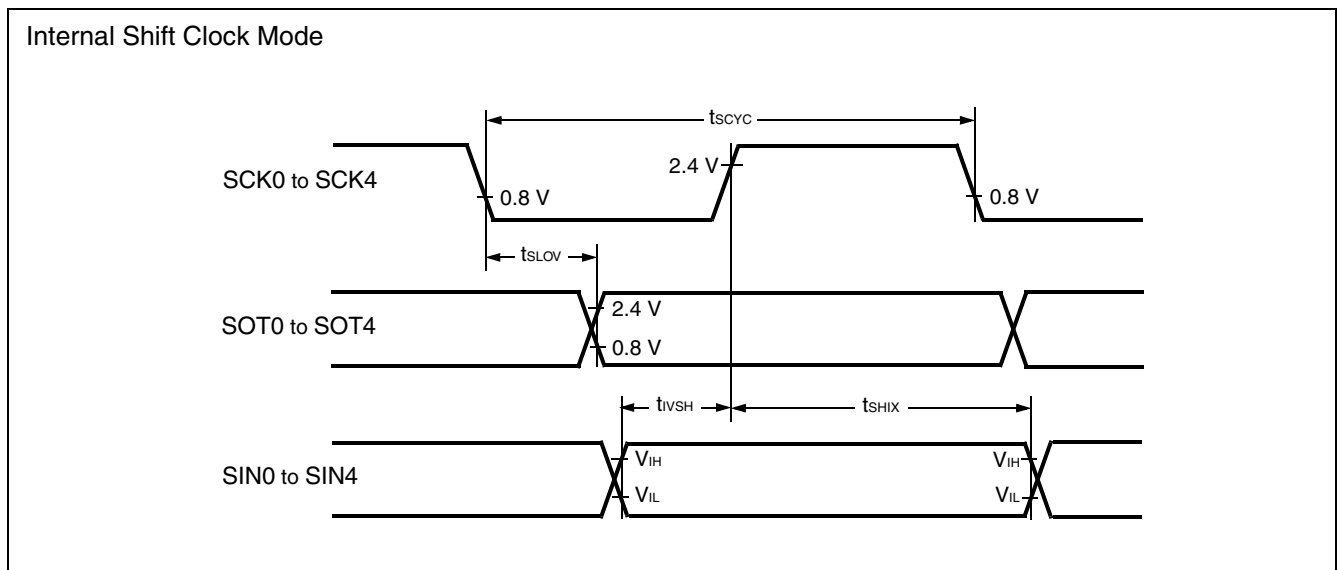

MB90340E Series

External Shift Clock Mode

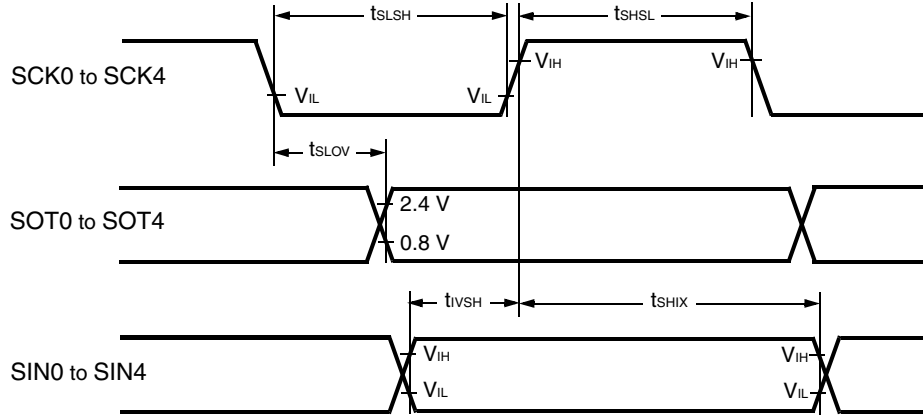

(10) Trigger Input Timing

($T_A = -40\text{ }^\circ\text{C}$ to $+105\text{ }^\circ\text{C}$, $V_{CC} = 5.0\text{ V} \pm 10\%$, $f_{CP} \leq 24\text{ MHz}$, $V_{SS} = 0.0\text{ V}$)

| Parameter | Symbol | Pin | Condition | Value | | Unit |
|-------------------|--------------------------|--|-----------|------------|-----|------|
| | | | | Min | Max | |
| Input pulse width | t_{TRGH} t_{TRGL} | INT0 to INT15, INT0R to INT15R, ADTG | — | $5 t_{CP}$ | — | ns |



(11) Timer Related Resource Input Timing

($T_A = -40\text{ }^\circ\text{C}$ to $+105\text{ }^\circ\text{C}$, $V_{CC} = 5.0\text{ V} \pm 10\%$, $f_{CP} \leq 24\text{ MHz}$, $V_{SS} = 0\text{ V}$)

| Parameter | Symbol | Pin | Condition | Value | | Unit |
|-------------------|------------|-----------------------------|-----------|------------|-----|------|
| | | | | Min | Max | |
| Input pulse width | t_{TIWH} | TIN0 to TIN3, IN0 to IN7 | — | 4 t_{CP} | — | ns |
| | t_{TIWL} | | | | | |

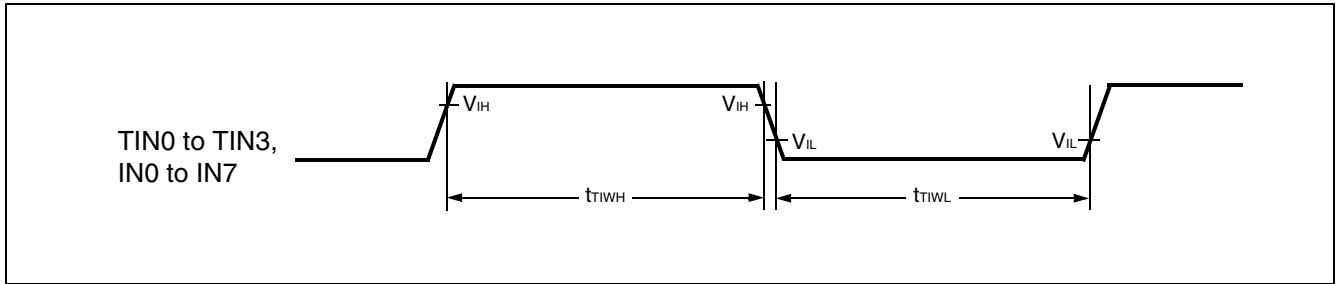

(12) Timer Related Resource Output Timing

($T_A = -40\text{ }^\circ\text{C}$ to $+105\text{ }^\circ\text{C}$, $V_{CC} = 5.0\text{ V} \pm 10\%$, $f_{CP} \leq 24\text{ MHz}$, $V_{SS} = 0.0\text{ V}$)

| Parameter | Symbol | Pin | Condition | Value | | Unit |
|--|----------|-------------------------------|-----------|-------|-----|------|
| | | | | Min | Max | |
| CLK \uparrow \rightarrow T_{OUT} change time | t_{TO} | TOT0 to TOT3, PPG0 to PPGF | — | 30 | — | ns |

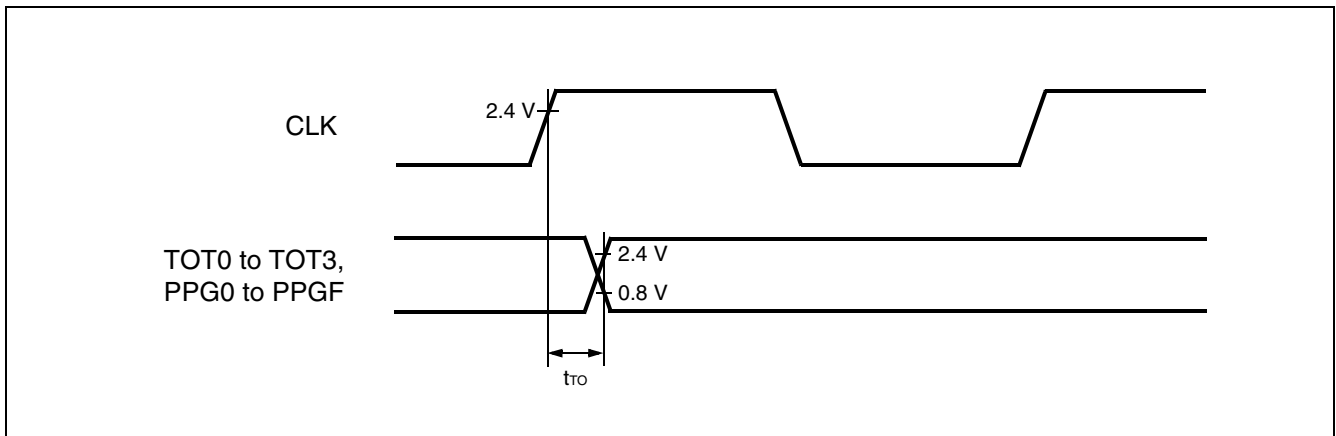

MB90340E Series

(13) I²C Timing

(T_A = -40°C to +105°C, V_{CC} = 5.0 V ± 10%, V_{SS} = 0.0 V)

| Parameter | Symbol | Condition | Standard-mode | | Fast-mode* ¹ | | Unit |
|---|--------------------|--|---------------|--------------------|-------------------------|-------------------|------|
| | | | Min | Max | Min | Max | |
| SCL clock frequency | f _{SCL} | R = 1.7 kΩ, C = 50 pF* ² | 0 | 100 | 0 | 400 | kHz |
| Hold time (repeated) START condition SDA ↓ → SCL ↓ | t _{HDSTA} | | 4.0 | — | 0.6 | — | μs |
| “L” width of the SCL clock | t _{LOW} | | 4.7 | — | 1.3 | — | μs |
| “H” width of the SCL clock | t _{HIGH} | | 4.0 | — | 0.6 | — | μs |
| Set-up time (repeated) START condition SCL ↑ → SDA ↓ | t _{SUSTA} | | 4.7 | — | 0.6 | — | μs |
| Data hold time SCL ↓ → SDA ↓ ↑ | t _{HDDAT} | | 0 | 3.45* ³ | 0 | 0.9* ⁴ | μs |
| Data set-up time SDA ↓ ↑ → SCL ↑ | t _{SUDAT} | | 250 | — | 100 | — | ns |
| Set-up time for STOP condition SCL ↑ → SDA ↑ | t _{SUSTO} | | 4.0 | — | 0.6 | — | μs |
| Bus free time between a STOP and START condition | t _{BUS} | 4.7 | — | 1.3 | — | μs | |

*1: For use at over 100 kHz, set the machine clock to at least 6 MHz.

*2: R,C: Pull-up resistor and load capacitor of the SCL and SDA lines.

*3: The maximum t_{HDDAT} meets the requirement that it does not extend the “L” width (t_{LOW}) of the SCL signal.

*4: A Fast-mode I²C-bus device can be used in a Standard-mode I²C-bus system, but the requirement t_{SUDAT} ≥ 250 ns must then be met.

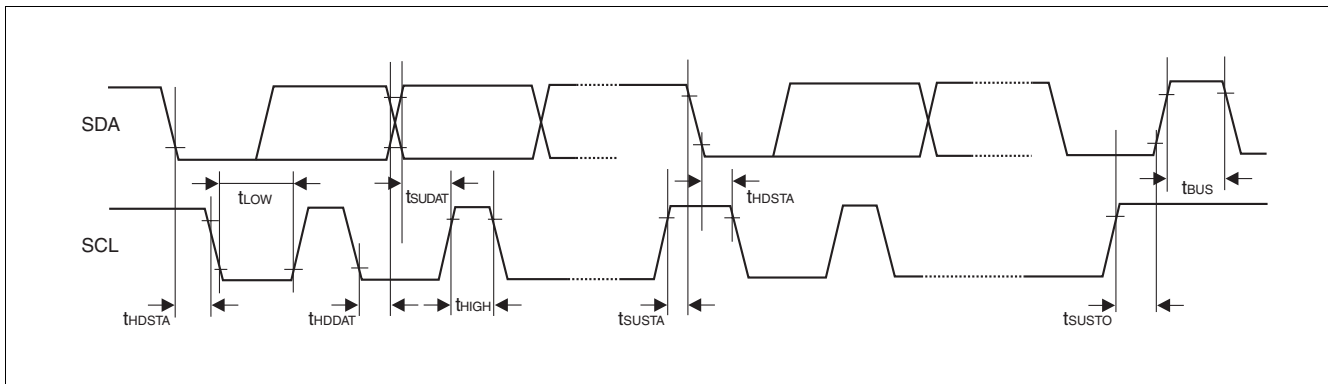

5. A/D Converter

($T_A = -40\text{ }^\circ\text{C}$ to $+105\text{ }^\circ\text{C}$, $3.0\text{ V} \leq AVRH - AVRL$, $V_{CC} = AV_{CC} = 5.0\text{ V} \pm 10\%$, $f_{CP} \leq 24\text{ MHz}$, $V_{SS} = AV_{SS} = 0\text{ V}$)

| Parameter | Symbol | Pin | Value | | | Unit | Remarks |
|---------------------------------|-----------|-------------|--------------|--------------|--------------|---------------|---|
| | | | Min | Typ | Max | | |
| Resolution | — | — | — | — | 10 | bit | |
| Total error | — | — | — | — | ± 3.0 | LSB | |
| Nonlinearity error | — | — | — | — | ± 2.5 | LSB | |
| Differential nonlinearity error | — | — | — | — | ± 1.9 | LSB | |
| Zero reading voltage | V_{OT} | AN0 to AN23 | $AVRL - 1.5$ | $AVRL + 0.5$ | $AVRL + 2.5$ | LSB | |
| Full scale reading voltage | V_{FST} | AN0 to AN23 | $AVRH - 3.5$ | $AVRH - 1.5$ | $AVRH + 0.5$ | LSB | |
| Compare time | — | — | 1.0 | — | 16500 | μs | $4.5\text{ V} \leq AV_{CC} \leq 5.5\text{ V}$ |
| | | | 2.0 | | | | $4.0\text{ V} \leq AV_{CC} < 4.5\text{ V}$ |
| Sampling time | — | — | 0.5 | — | ∞ | μs | $4.5\text{ V} \leq AV_{CC} \leq 5.5\text{ V}$ |
| | | | 1.2 | | | | $4.0\text{ V} \leq AV_{CC} < 4.5\text{ V}$ |
| Analog port input current | I_{AIN} | AN0 to AN23 | -0.3 | — | +0.3 | μA | |
| Analog input voltage range | V_{AIN} | AN0 to AN23 | AVRL | — | AVRH | V | |
| Reference voltage range | — | AVRH | $AVRL + 2.7$ | — | AV_{CC} | V | |
| | — | AVRL | 0 | — | $AVRH - 2.7$ | V | |
| Power supply current | I_A | AV_{CC} | — | 3.5 | 7.5 | mA | |
| | I_{AH} | AV_{CC} | — | — | 5 | μA | * |
| Reference voltage current | I_R | AVRH | — | 600 | 900 | μA | |
| | I_{RH} | AVRH | — | — | 5 | μA | * |
| Offset between input channels | — | AN0 to AN23 | — | — | 4 | LSB | |

*: If the A/D convertor is not operating, a current when CPU is stopped is applicable ($V_{CC} = AV_{CC} = AVRH = 5.0\text{ V}$).

Note: The accuracy gets worse as $|AVRH - AVRL|$ becomes smaller.

MB90340E Series

6. Definition of A/D Converter Terms

- Resolution : Analog variation that is recognized by the A/D converter.
- Non linearity error : The deviation between the actual conversion characteristics and a line that joins the zero-transition line ("00 0000 0000" ← → "00 0000 0001") to the full-scale transition line ("11 1111 1110" ← → "11 1111 1111") .
- Differential linearity error : Deviation of input voltage, which is required for changing output code by 1 LSB, from an ideal value.
- Total error : Difference between the actual value and the ideal value. The total error includes zero transition error, full-scale transition error, and linear error.

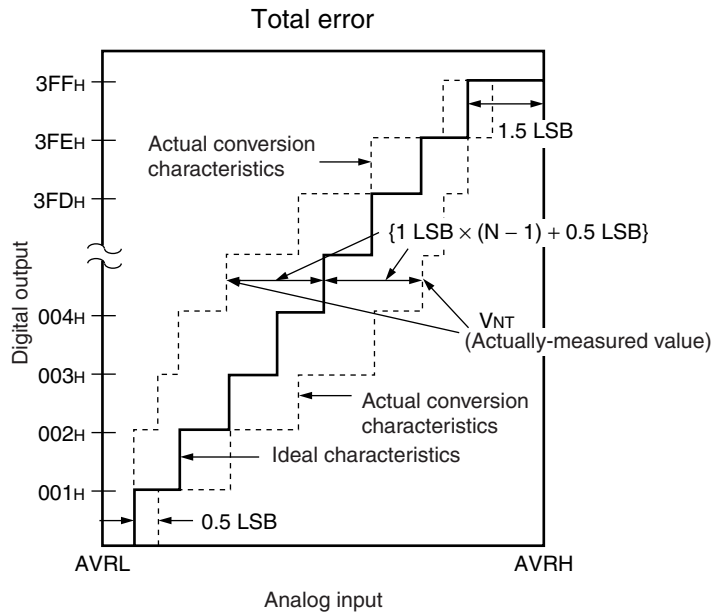

$$\text{Total error of digital output "N"} = \frac{V_{NT} - \{1 \text{ LSB} \times (N - 1) + 0.5 \text{ LSB}\}}{1 \text{ LSB}} \text{ [LSB]}$$

$$1 \text{ LSB (Ideal value)} = \frac{AVRH - AVRL}{1024} \text{ [V]}$$

N : Value of the digital output from the A/D converter

V_{OT} (Ideal value) = AVRL + 0.5 LSB [V]

V_{FST} (Ideal value) = AVRH - 1.5 LSB [V]

V_{NT} : A voltage at which the digital output transitions from (N - 1)_H to N_H.

(Continued)

(Continued)

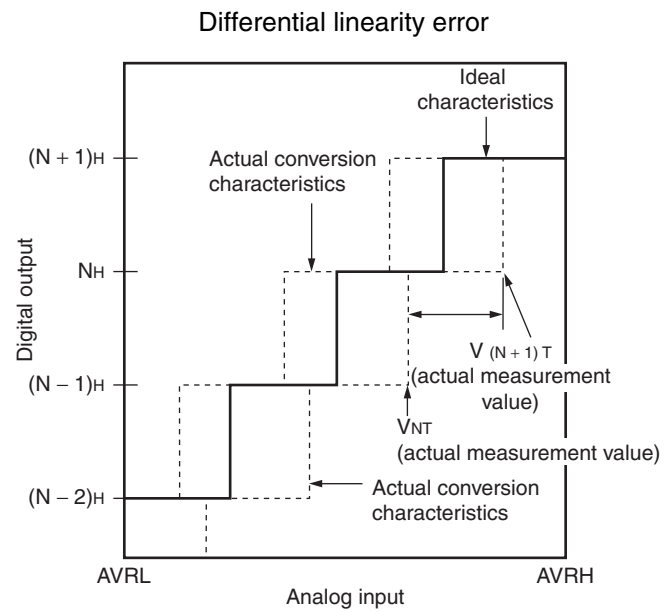
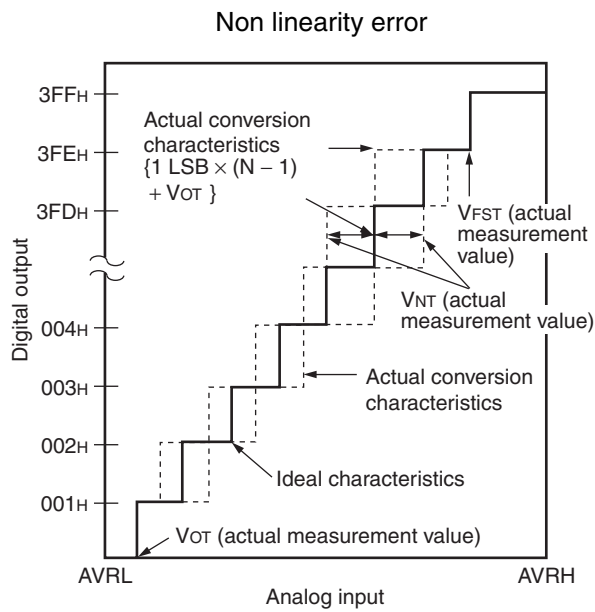

$$\text{Non linearity error of digital output } N = \frac{V_{NT} - \{1 \text{ LSB} \times (N - 1) + V_{OT}\}}{1 \text{ LSB}} \text{ [LSB]}$$

$$\text{Differential linearity error of digital output } N = \frac{V_{(N+1)T} - V_{NT}}{1 \text{ LSB}} - 1 \text{ LSB [LSB]}$$

$$1 \text{ LSB} = \frac{V_{FST} - V_{OT}}{1022} \text{ [V]}$$

N : Value of the digital output from the A/D converter

V_{OT} : Voltage at which digital output transits from "000_H" to "001_H."

V_{FST} : Voltage at which digital output transits from "3FE_H" to "3FF_H."

MB90340E Series

7. Notes on A/D Converter Section

Use the device with external circuits of the following output impedance for analog inputs :

Recommended output impedance of external circuits are : Approx. 1.5 k Ω or lower ($4.0\text{ V} \leq AV_{CC} \leq 5.5\text{ V}$,
sampling period = 0.5 μs)

If an external capacitor is used, in consideration of the capacitive voltage dividing effect between the external capacitor and the internal on-chip capacitor, it is recommended that the capacitance of the external capacitor be several thousand times greater than the capacitance of the internal capacitor.

If the output impedance of the external circuit is too high, a sampling period for an analog voltage may be insufficient.

• Analog input circuit model

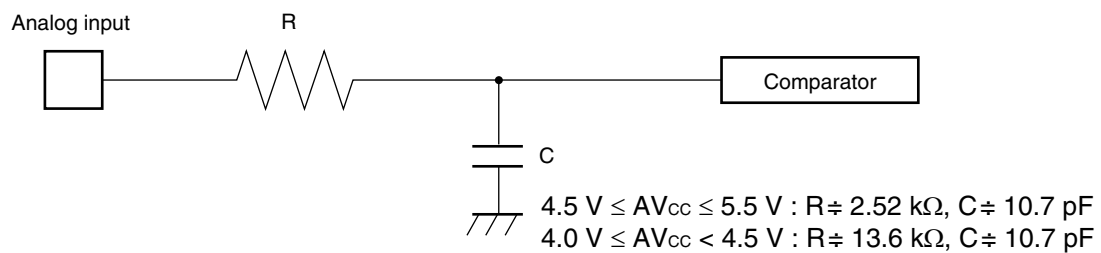

Note : Use the values in the figure only as a guideline.

8. Flash Memory Program/Erase Characteristics

| Parameter | Conditions | Value | | | Unit | Remarks |
|--------------------------------------|--|-------|-----|------|-------|---|
| | | Min | Typ | Max | | |
| Sector erase time | T _A = +25 °C V _{CC} = 5.0 V | — | 1 | 15 | s | Excludes programming prior to erasure |
| Chip erase time | | — | 9 | — | s | Excludes programming prior to erasure |
| Word (16-bit width) programming time | | — | 16 | 3600 | μs | Except for the over head time of the system |
| Program/Erase cycle | — | 10000 | — | — | cycle | |
| Flash Data Retention Time | Average T _A = +85 °C | 20 | — | — | year | * |

* : This value was converted from the results of evaluating the reliability of the technology (using Arrhenius equation to translate high temperature measurements into normalized value at +85 °C) .

MB90340E Series

EXAMPLE CHARACTERISTICS

- MB90F346E, MB90F346ES, MB90F346CE, MB90F346CES

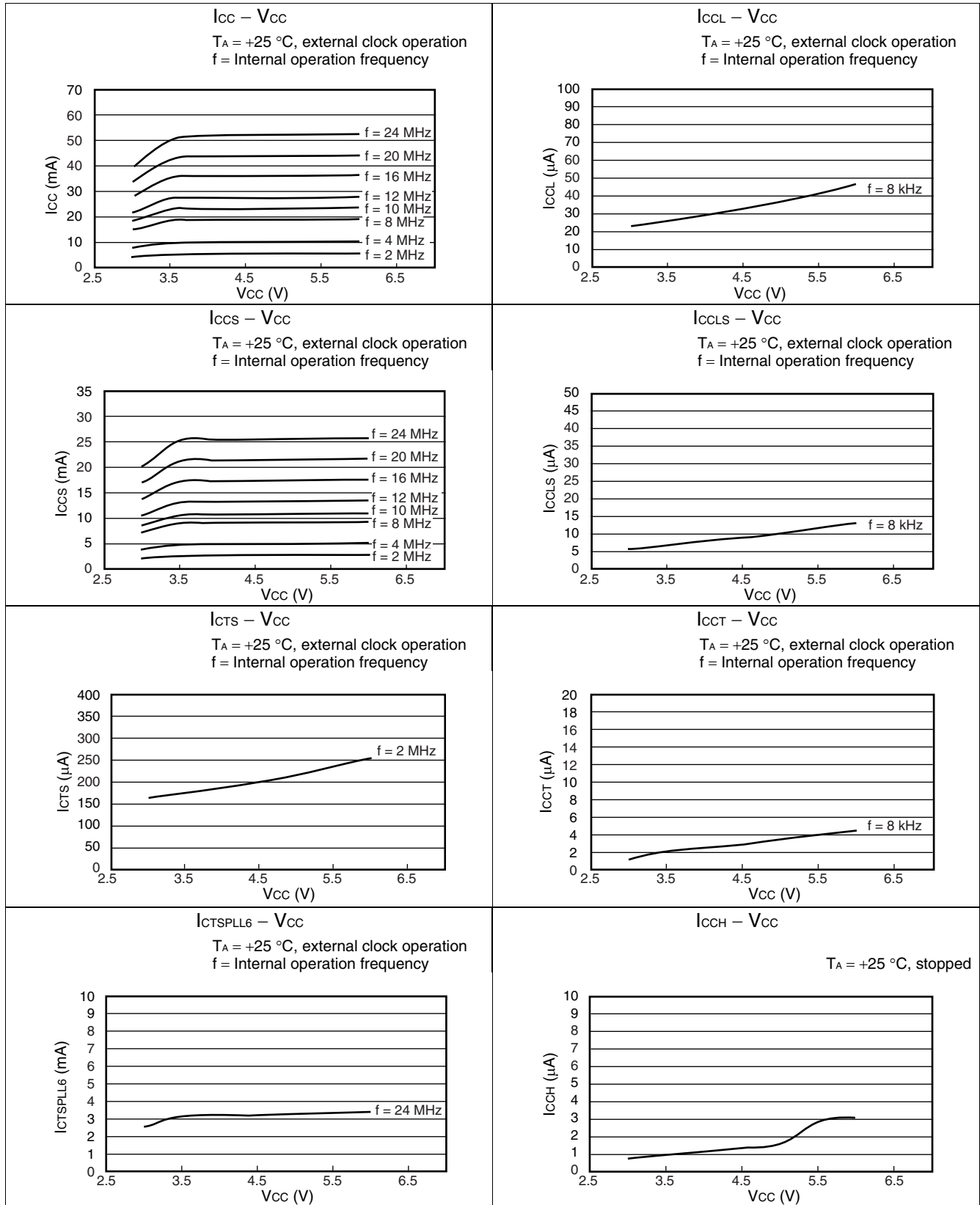

MB90340E Series

- MB90F347E, MB90F347ES, MB90F347CE, MB90F347CES

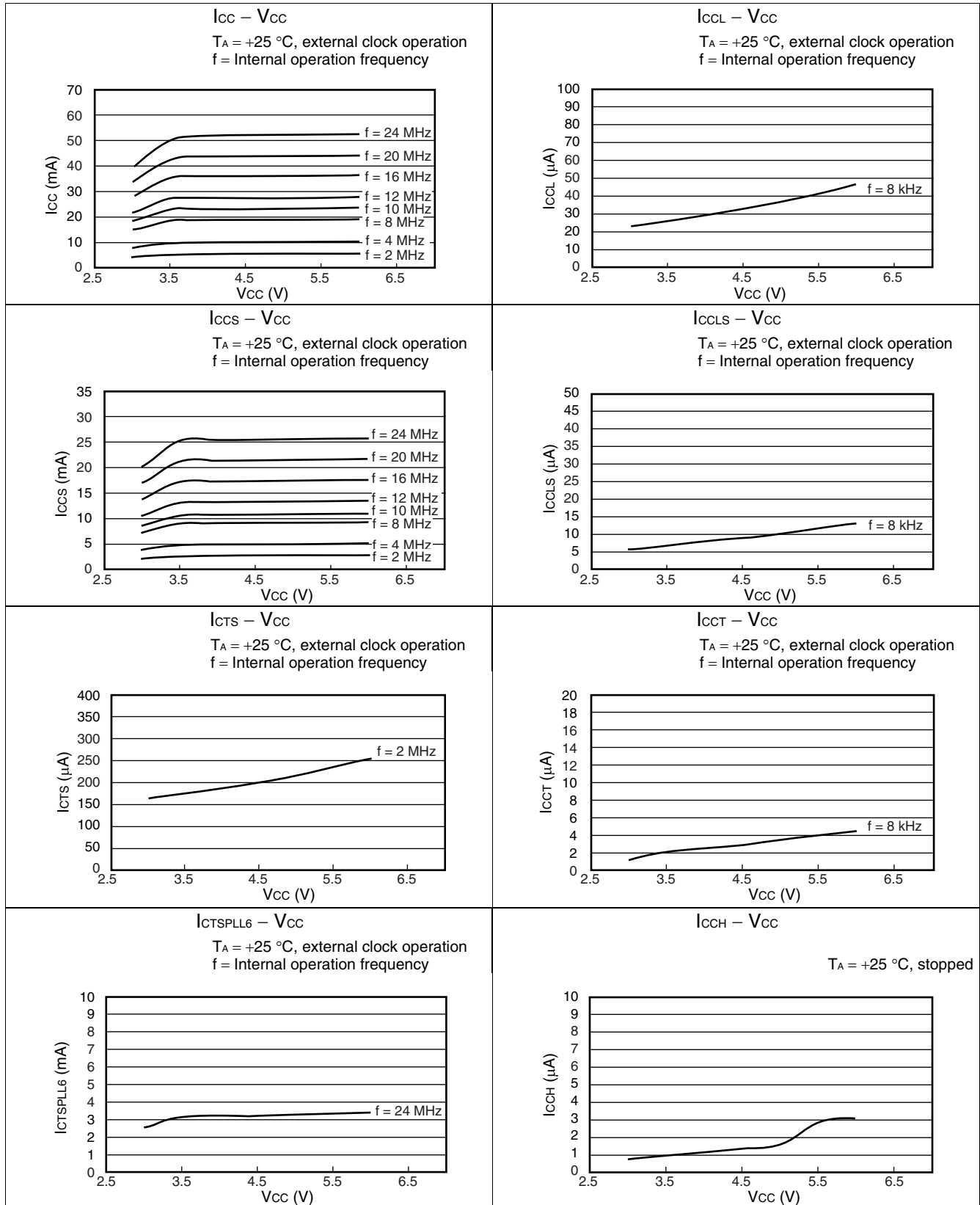

MB90340E Series

- MB90F349E, MB90F349ES, MB90F349CE, MB90F349CES

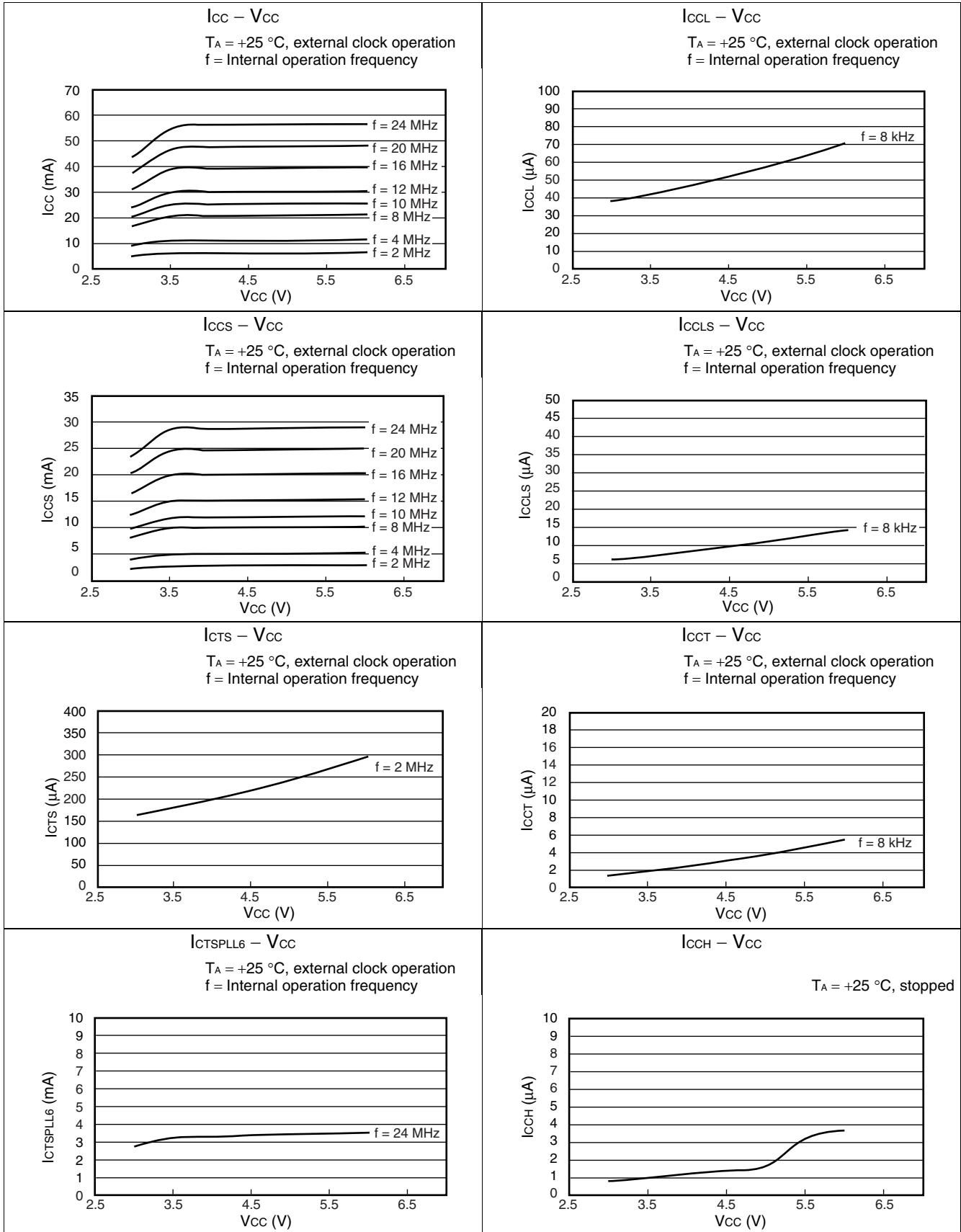

MB90340E Series

- MB90F342E, MB90F342ES, MB90F342CE, MB90F342CES

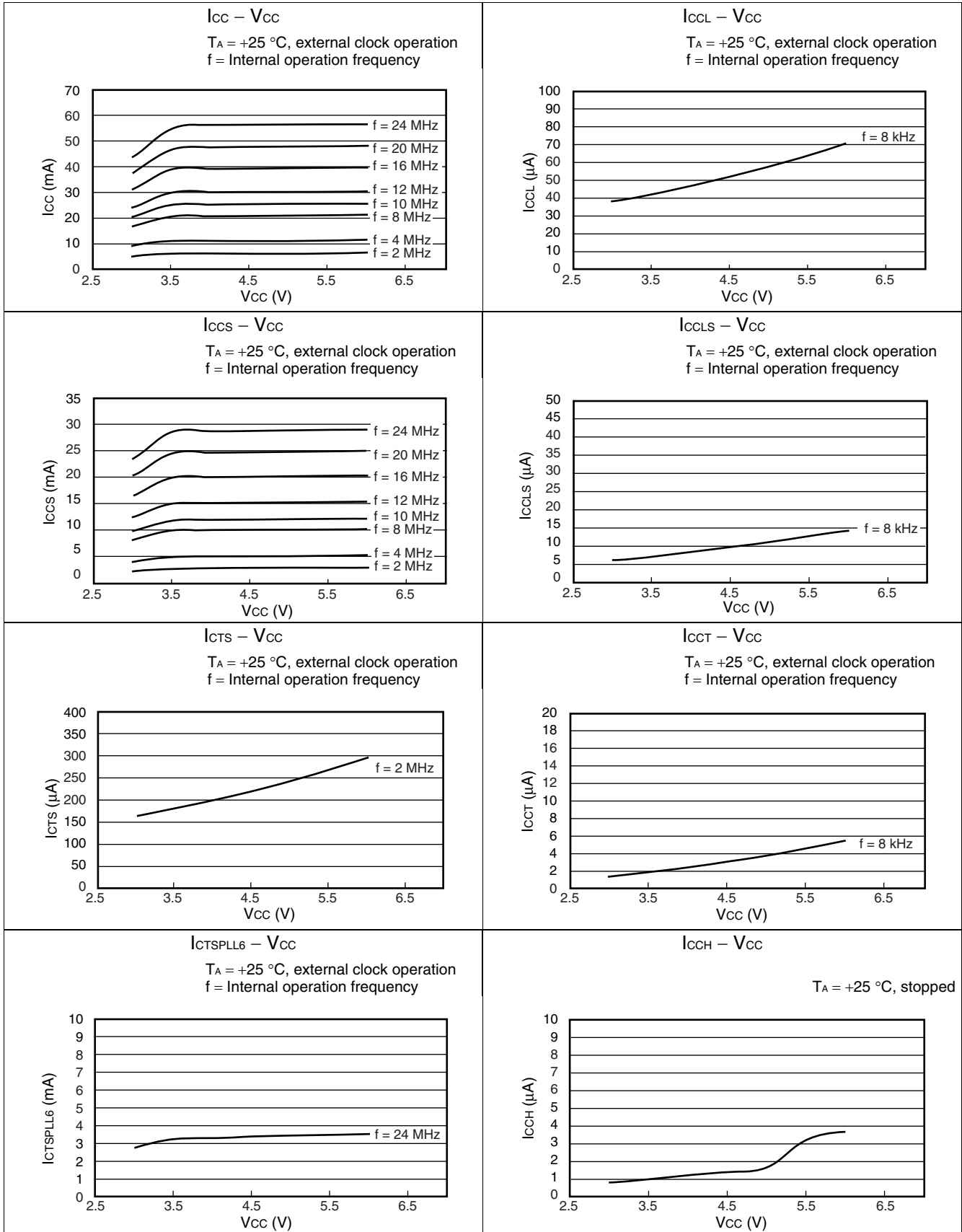

MB90340E Series

- MB90F345E, MB90F345ES, MB90F345CE, MB90F345CES

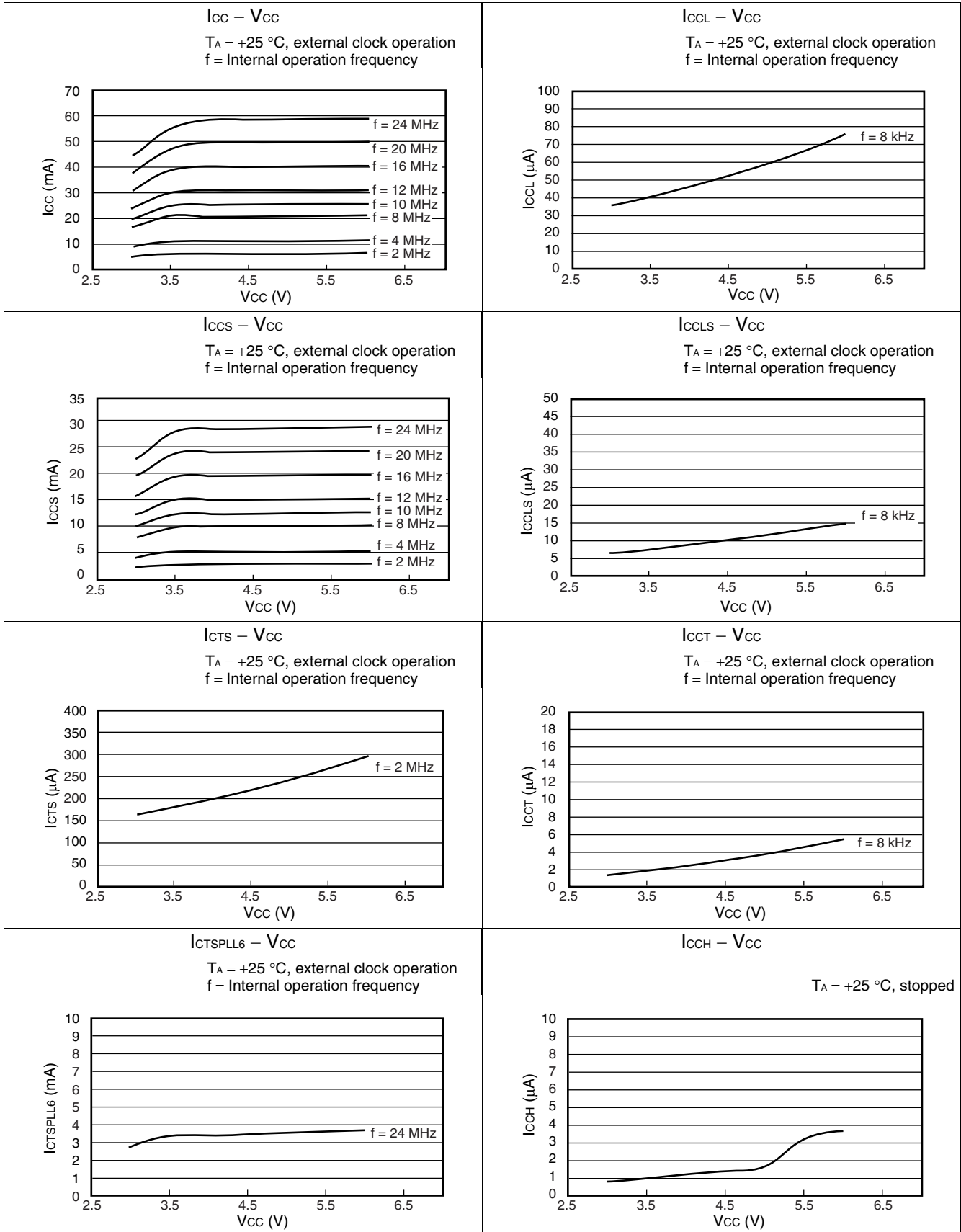

MB90340E Series

- MB90346E, MB90346ES, MB90346CE, MB90346CES

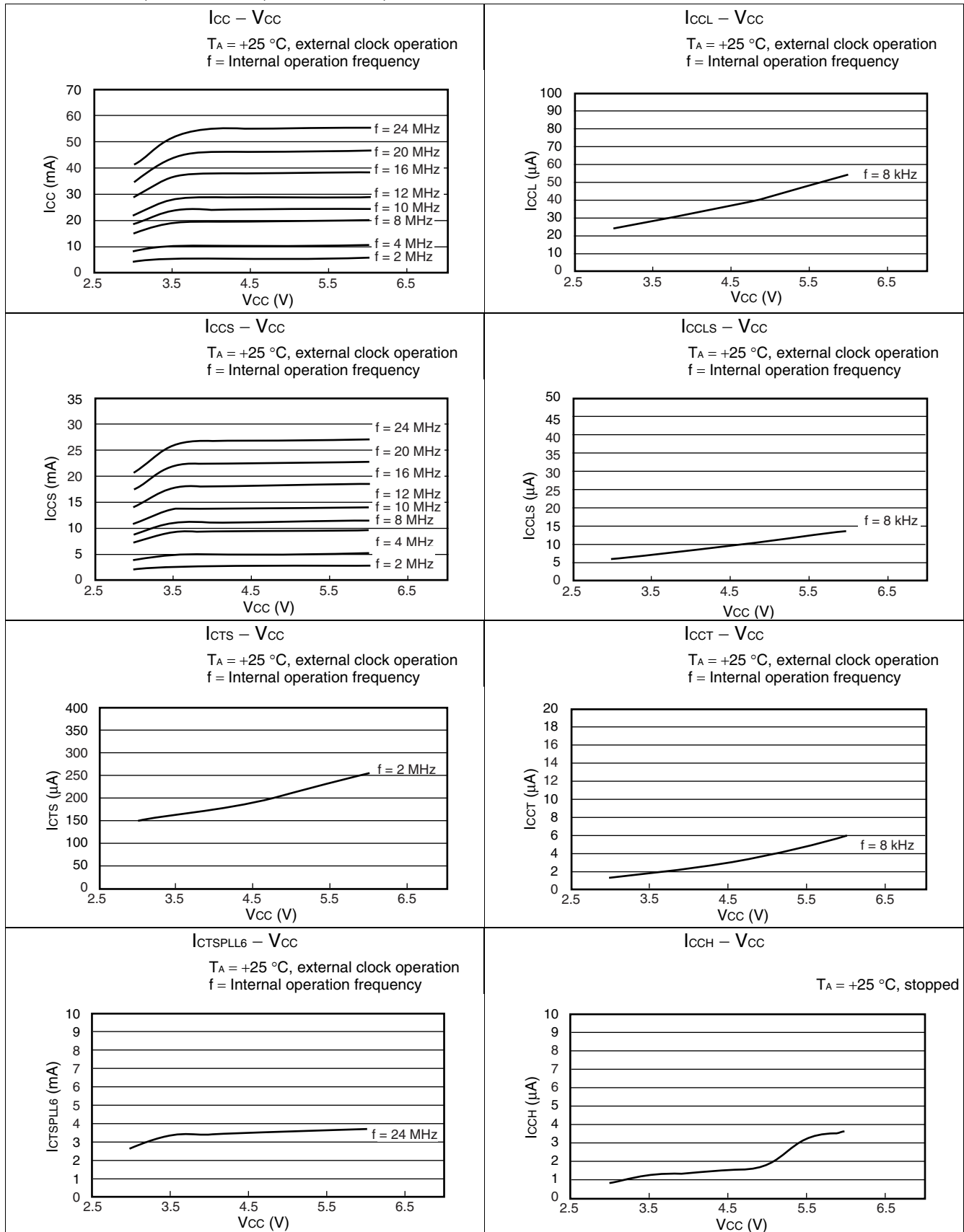

MB90340E Series

- MB90347E, MB90347ES, MB90347CE, MB90347CES

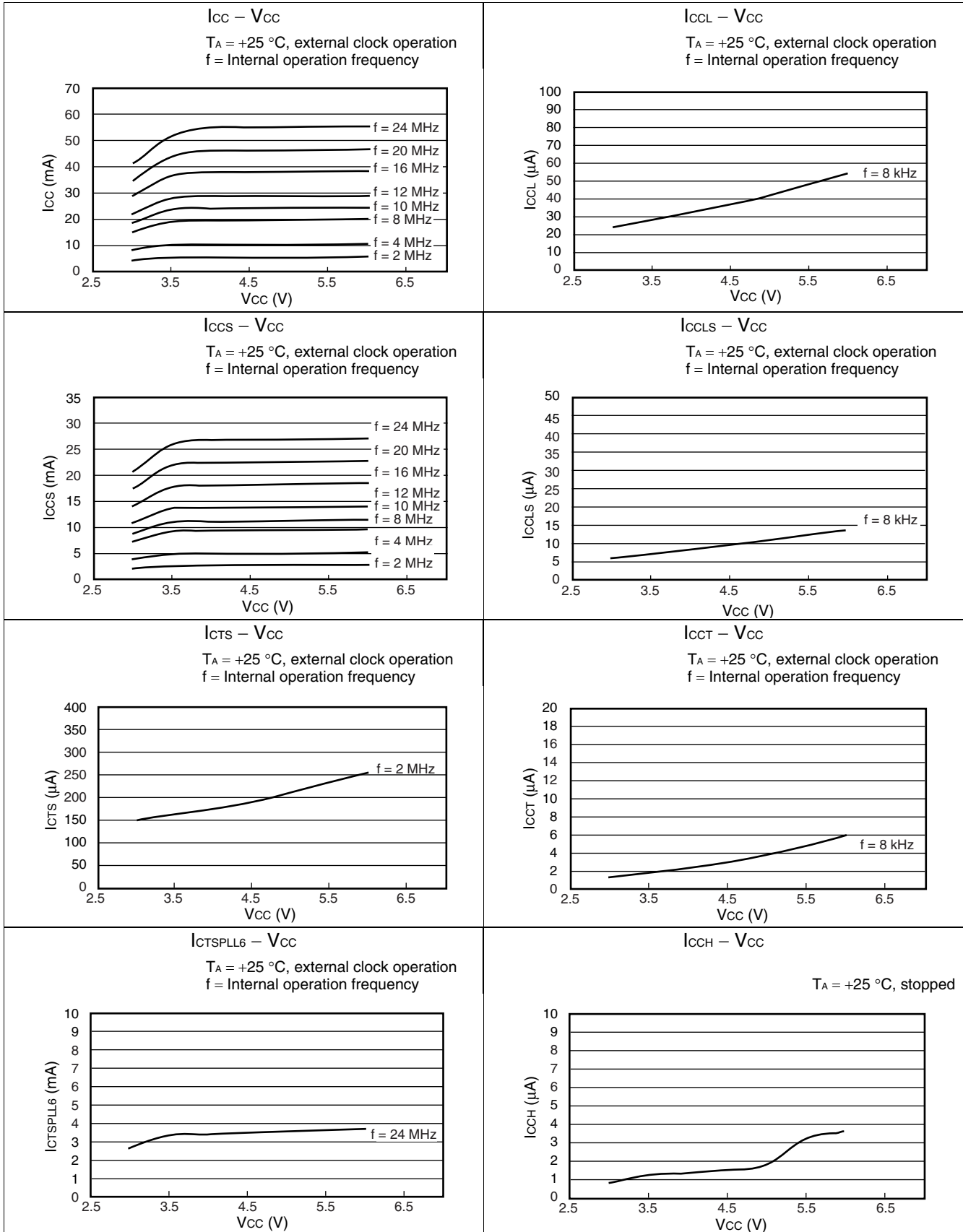

MB90340E Series

I/O characteristics

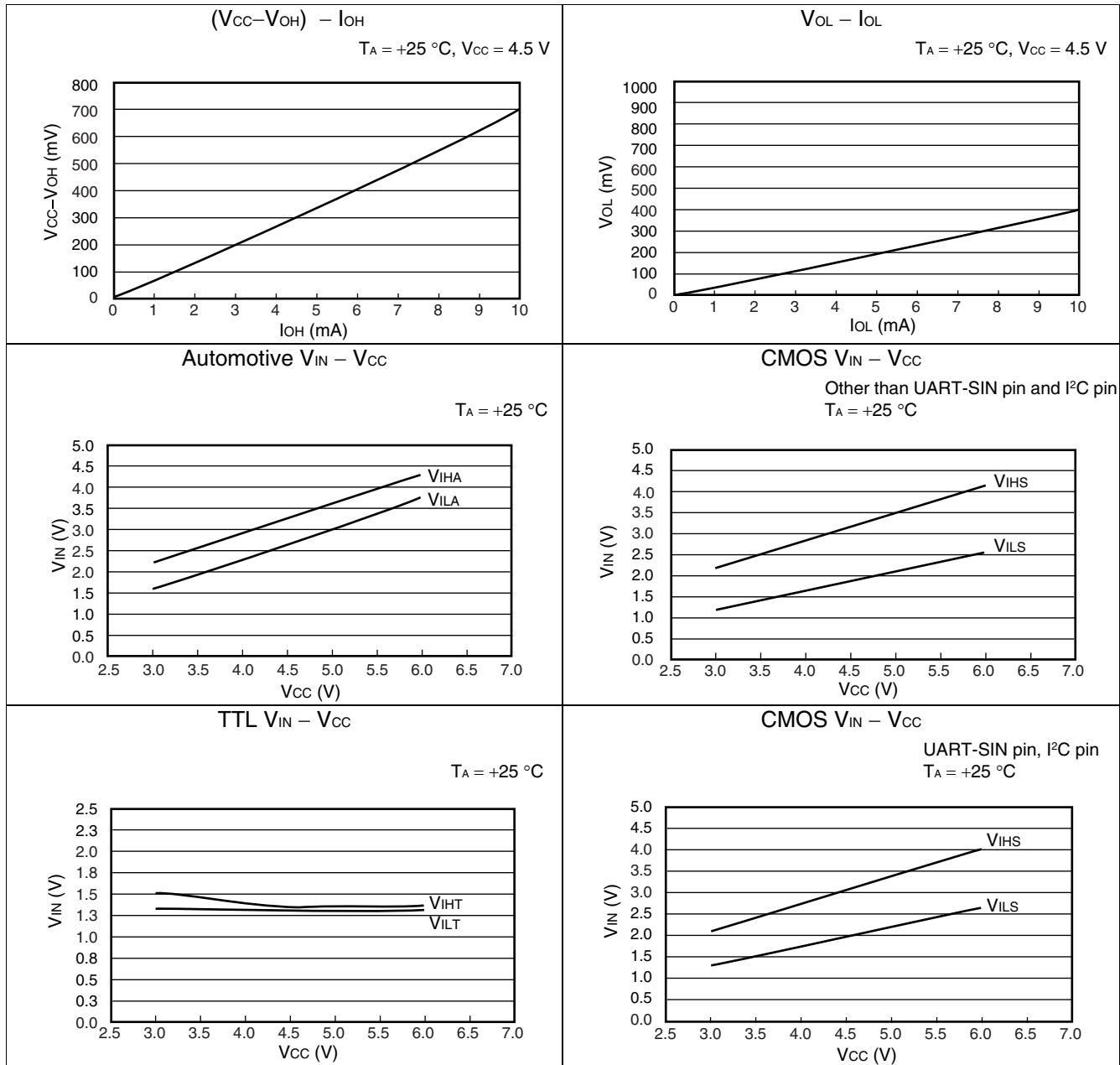

MB90340E Series

■ ORDERING INFORMATION

| Part number | Package | Remarks | |
|----------------|--|---------|--|
| MB90F342EPF | 100-pin plastic QFP (FPT-100P-M06) | | |
| MB90F342ESPF | | | |
| MB90F342CEPF | | | |
| MB90F342CESPF | | | |
| MB90F342EPFV | 100-pin plastic LQFP (FPT-100P-M05) | | |
| MB90F342ESPFV | | | |
| MB90F342CEPFV | | | |
| MB90F342CESPFV | | | |
| MB90F343EPF | 100-pin plastic QFP (FPT-100P-M06) | | |
| MB90F343ESPF | | | |
| MB90F343CEPF | | | |
| MB90F343CESPF | | | |
| MB90F343EPFV | 100-pin plastic LQFP (FPT-100P-M05) | | |
| MB90F343ESPFV | | | |
| MB90F343CEPFV | | | |
| MB90F343CESPFV | | | |
| MB90F345EPF | 100-pin plastic QFP (FPT-100P-M06) | | |
| MB90F345ESPF | | | |
| MB90F345CEPF | | | |
| MB90F345CESPF | | | |
| MB90F345EPFV | 100-pin plastic LQFP (FPT-100P-M05) | | |
| MB90F345ESPFV | | | |
| MB90F345CEPFV | | | |
| MB90F345CESPFV | | | |
| MB90F346EPF | 100-pin plastic QFP (FPT-100P-M06) | | |
| MB90F346ESPF | | | |
| MB90F346CEPF | | | |
| MB90F346CESPF | | | |
| MB90F346EPFV | 100-pin plastic LQFP (FPT-100P-M05) | | |
| MB90F346ESPFV | | | |
| MB90F346CEPFV | | | |
| MB90F346CESPFV | | | |

(Continued)

MB90340E Series

| Part number | Package | Remarks |
|----------------|--|---------|
| MB90F347EPF | 100-pin plastic QFP (FPT-100P-M06) | |
| MB90F347ESPF | | |
| MB90F347CEPF | | |
| MB90F347CESPF | | |
| MB90F347EPFV | 100-pin plastic LQFP (FPT-100P-M05) | |
| MB90F347ESPFV | | |
| MB90F347CEPFV | | |
| MB90F347CESPFV | | |
| MB90F349EPF | 100-pin plastic QFP (FPT-100P-M06) | |
| MB90F349ESPF | | |
| MB90F349CEPF | | |
| MB90F349CESPF | | |
| MB90F349EPFV | 100-pin plastic LQFP (FPT-100P-M05) | |
| MB90F349ESPFV | | |
| MB90F349CEPFV | | |
| MB90F349CESPFV | | |
| MB90341EPF | 100-pin plastic QFP (FPT-100P-M06) | |
| MB90341ESPF | | |
| MB90341CEPF | | |
| MB90341CESPF | | |
| MB90341EPFV | 100-pin plastic LQFP (FPT-100P-M05) | |
| MB90341ESPFV | | |
| MB90341CEPFV | | |
| MB90341CESPFV | | |
| MB90342EPF | 100-pin plastic QFP (FPT-100P-M06) | |
| MB90342ESPF | | |
| MB90342CEPF | | |
| MB90342CESPF | | |
| MB90342EPFV | 100-pin plastic LQFP (FPT-100P-M05) | |
| MB90342ESPFV | | |
| MB90342CEPFV | | |
| MB90342CESPFV | | |

(Continued)

MB90340E Series

(Continued)

| Part number | Package | Remarks |
|---------------|--|----------------|
| MB90346EPF | 100-pin plastic QFP (FPT-100P-M06) | |
| MB90346ESPF | | |
| MB90346CEPF | | |
| MB90346CESPF | | |
| MB90346EPFV | 100-pin plastic LQFP (FPT-100P-M05) | |
| MB90346ESPFV | | |
| MB90346CEPFV | | |
| MB90346CESPFV | | |
| MB90347EPF | 100-pin plastic QFP (FPT-100P-M06) | |
| MB90347ESPF | | |
| MB90347CEPF | | |
| MB90347CESPF | | |
| MB90347EPFV | 100-pin plastic LQFP (FPT-100P-M05) | |
| MB90347ESPFV | | |
| MB90347CEPFV | | |
| MB90347CESPFV | | |
| MB90348EPF | 100-pin plastic QFP (FPT-100P-M06) | |
| MB90348ESPF | | |
| MB90348CEPF | | |
| MB90348CESPF | | |
| MB90348EPFV | 100-pin plastic LQFP (FPT-100P-M05) | |
| MB90348ESPFV | | |
| MB90348CEPFV | | |
| MB90348CESPFV | | |
| MB90349EPF | 100-pin plastic QFP (FPT-100P-M06) | |
| MB90349ESPF | | |
| MB90349CEPF | | |
| MB90349CESPF | | |
| MB90349EPFV | 100-pin plastic LQFP (FPT-100P-M05) | |
| MB90349ESPFV | | |
| MB90349CEPFV | | |
| MB90349CESPFV | | |
| MB90V340E-101 | 299-pin ceramic PGA (PGA-299C-A01) | For evaluation |
| MB90V340E-102 | | |

■ PACKAGE DIMENSIONS

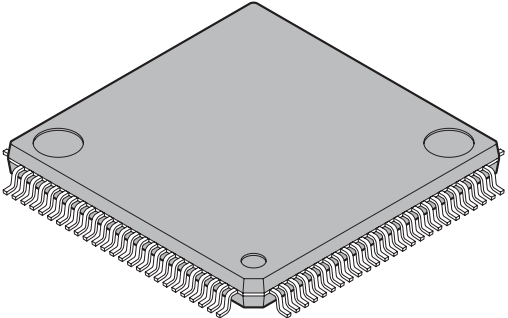
| | | |
|---|--------------------------------|-----------------------|
| <p>100-pin plastic LQFP</p>  <p>(FPT-100P-M05)</p> | Lead pitch | 0.50 mm |
| | Package width × package length | 14.0 × 14.0 mm |
| | Lead shape | Gullwing |
| | Sealing method | Plastic mold |
| | Mounting height | 1.70 mm MAX |
| | Weight | 0.65g |
| | Code (Reference) | P-LFQFP100-14×14-0.50 |

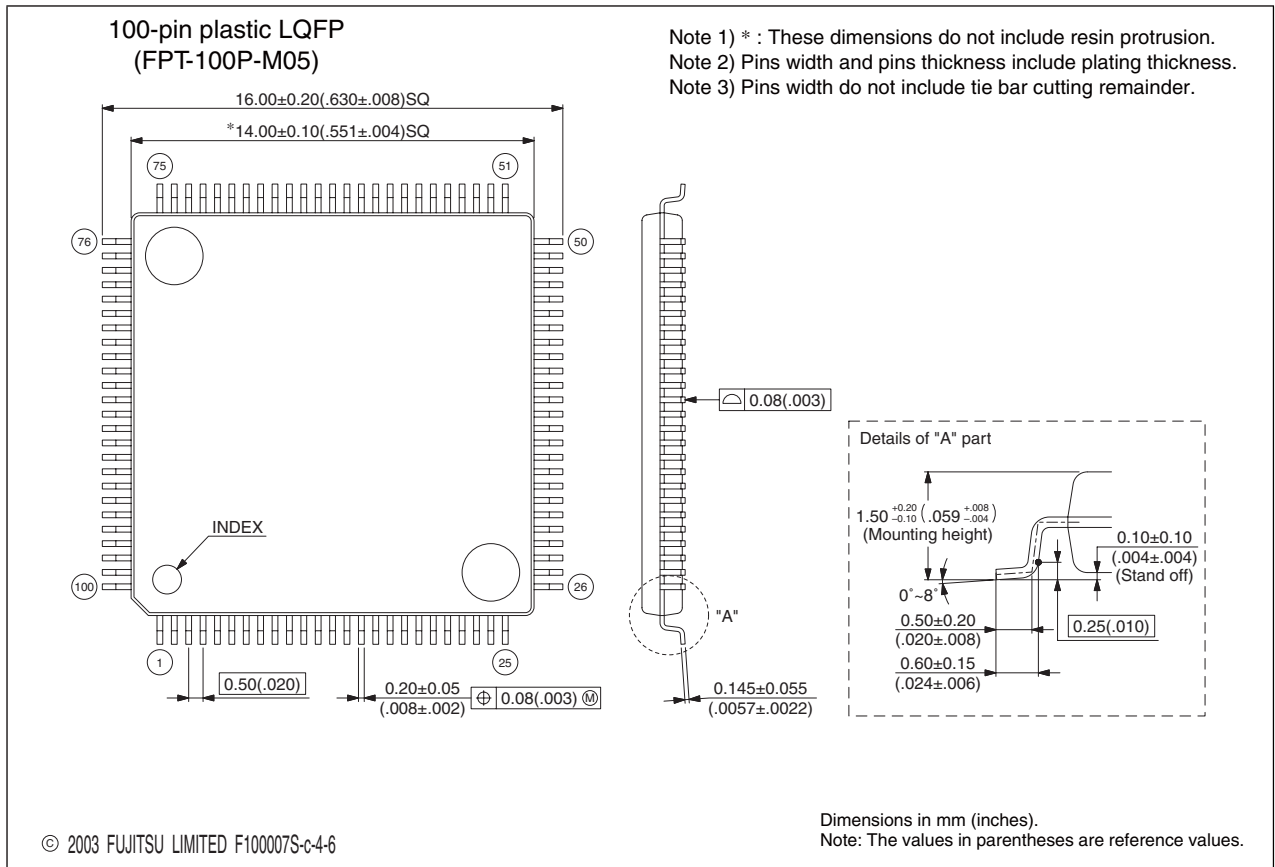

Please confirm the latest Package dimension by following URL.
<http://edevic.fujitsu.com/package/en-search/>

(Continued)

MB90340E Series

(Continued)

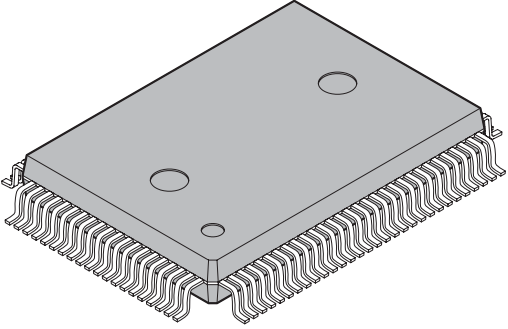
| | | |
|--|--------------------------------|---------------------|
| <p>100-pin plastic QFP</p>  <p>(FPT-100P-M06)</p> | Lead pitch | 0.65 mm |
| | Package width × package length | 14.00 × 20.00 mm |
| | Lead shape | Gullwing |
| | Sealing method | Plastic mold |
| | Mounting height | 3.35 mm MAX |
| | Code (Reference) | P-QFP100-14×20-0.65 |
| | | |

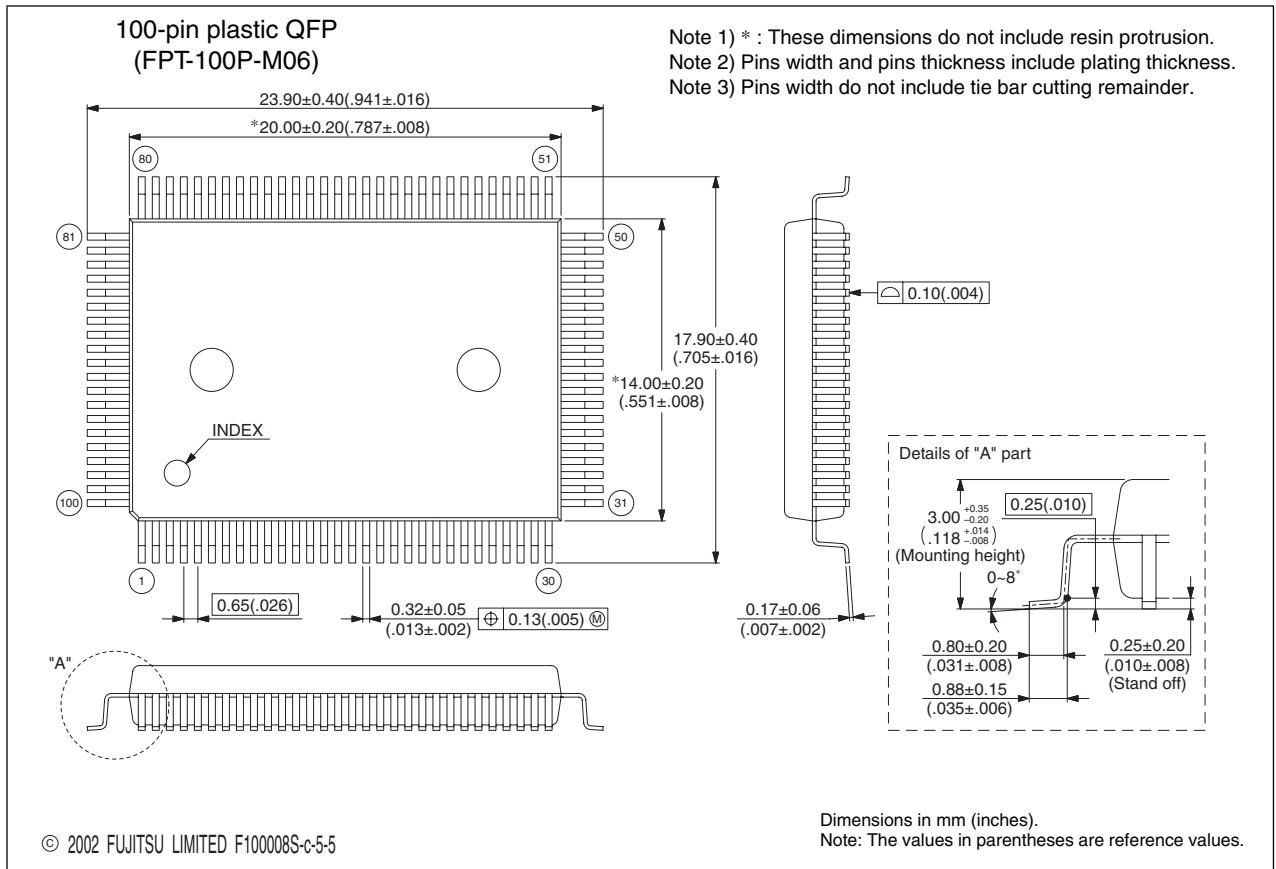

Please confirm the latest Package dimension by following URL.
<http://edevice.fujitsu.com/package/en-search/>

■ MAIN CHANGES IN THIS EDITION

| Page | Section | Change Results |
|----------|--|---|
| 3 | ■ FEATURES | Added a description of the "• Clock modulation circuit". |
| 37 | ■ I/O MAP | Changed the row 0079C _H |
| 38 | Address 007E00 _H to 007FFF _H | Changed as follows; Reserved for CAN Controller 2. Refer to "■ CAN CONTROLLERS"→ Reserved |
| 39 to 45 | ■ CAN CONTROLLERS | Deleted the address of CAN2 |

The vertical lines marked in the left side of the page show the changes.

FUJITSU MICROELECTRONICS LIMITED

Shinjuku Dai-Ichi Seimei Bldg. 7-1, Nishishinjuku 2-chome, Shinjuku-ku,
Tokyo 163-0722, Japan Tel: +81-3-5322-3347 Fax: +81-3-5322-3387
<http://jp.fujitsu.com/fml/en/>

For further information please contact:

North and South America

FUJITSU MICROELECTRONICS AMERICA, INC.
1250 E. Arques Avenue, M/S 333
Sunnyvale, CA 94085-5401, U.S.A.
Tel: +1-408-737-5600 Fax: +1-408-737-5999
<http://www.fma.fujitsu.com/>

Europe

FUJITSU MICROELECTRONICS EUROPE GmbH
Pittlerstrasse 47, 63225 Langen,
Germany
Tel: +49-6103-690-0 Fax: +49-6103-690-122
<http://emea.fujitsu.com/microelectronics/>

Korea

FUJITSU MICROELECTRONICS KOREA LTD.
206 KOSMO TOWER, 1002 Daechi-Dong,
Kangnam-Gu, Seoul 135-280
Korea
Tel: +82-2-3484-7100 Fax: +82-2-3484-7111
<http://www.fmk.fujitsu.com/>

Asia Pacific

FUJITSU MICROELECTRONICS ASIA PTE LTD.
151 Lorong Chuan, #05-08 New Tech Park,
Singapore 556741
Tel: +65-6281-0770 Fax: +65-6281-0220
<http://www.fujitsu.com/sg/services/micro/semiconductor/>

FUJITSU MICROELECTRONICS SHANGHAI CO., LTD.
Rm.3102, Bund Center, No.222 Yan An Road(E),
Shanghai 200002, China
Tel: +86-21-6335-1560 Fax: +86-21-6335-1605
<http://cn.fujitsu.com/fmc/>

FUJITSU MICROELECTRONICS PACIFIC ASIA LTD.
10/F., World Commerce Centre, 11 Canton Road
Tsimshatsui, Kowloon
Hong Kong
Tel: +852-2377-0226 Fax: +852-2376-3269
<http://cn.fujitsu.com/fmc/tw>

All Rights Reserved.

The contents of this document are subject to change without notice.

Customers are advised to consult with sales representatives before ordering.

The information, such as descriptions of function and application circuit examples, in this document are presented solely for the purpose of reference to show examples of operations and uses of FUJITSU MICROELECTRONICS device; FUJITSU MICROELECTRONICS does not warrant proper operation of the device with respect to use based on such information. When you develop equipment incorporating the device based on such information, you must assume any responsibility arising out of such use of the information.

FUJITSU MICROELECTRONICS assumes no liability for any damages whatsoever arising out of the use of the information.

Any information in this document, including descriptions of function and schematic diagrams, shall not be construed as license of the use or exercise of any intellectual property right, such as patent right or copyright, or any other right of FUJITSU MICROELECTRONICS or any third party or does FUJITSU MICROELECTRONICS warrant non-infringement of any third-party's intellectual property right or other right by using such information. FUJITSU MICROELECTRONICS assumes no liability for any infringement of the intellectual property rights or other rights of third parties which would result from the use of information contained herein.

The products described in this document are designed, developed and manufactured as contemplated for general use, including without limitation, ordinary industrial use, general office use, personal use, and household use, but are not designed, developed and manufactured as contemplated (1) for use accompanying fatal risks or dangers that, unless extremely high safety is secured, could have a serious effect to the public, and could lead directly to death, personal injury, severe physical damage or other loss (i.e., nuclear reaction control in nuclear facility, aircraft flight control, air traffic control, mass transport control, medical life support system, missile launch control in weapon system), or (2) for use requiring extremely high reliability (i.e., submersible repeater and artificial satellite).

Please note that FUJITSU MICROELECTRONICS will not be liable against you and/or any third party for any claims or damages arising in connection with above-mentioned uses of the products.

Any semiconductor devices have an inherent chance of failure. You must protect against injury, damage or loss from such failures by incorporating safety design measures into your facility and equipment such as redundancy, fire protection, and prevention of over-current levels and other abnormal operating conditions.

Exportation/release of any products described in this document may require necessary procedures in accordance with the regulations of the Foreign Exchange and Foreign Trade Control Law of Japan and/or US export control laws.

The company names and brand names herein are the trademarks or registered trademarks of their respective owners.