



STR91xFAxxx

ARM966E-S™ 16/32-bit Flash MCU with Ethernet, USB, CAN, AC motor control, 4 timers, ADC, RTC, DMA

Features

- 16/32-bit 96 MHz ARM9E based MCU
 - ARM966E-S RISC core: Harvard architecture, 5-stage pipeline, Tightly-Coupled Memories (SRAM and Flash)
 - STR91xFA implementation of core adds high-speed burst Flash memory interface, instruction prefetch queue, branch cache
 - Up to 96 MIPS directly from Flash memory
 - Single-cycle DSP instructions supported
 - Binary compatible with ARM7 code
- Dual burst Flash memories, 32-bits wide
 - 256 KB/512 KB/1 MB/2 MB main Flash
 - 32 KB/128 KB secondary Flash
 - Sequential Burst operation up to 96 MHz
 - 100 K min erase cycles, 20 yr min retention
- SRAM, 32-bits wide
 - 96K bytes, optional battery backup
- 9 programmable DMA channels
- Clock, reset, and supply management
 - Internal oscillator operating with external 4-25 MHz crystal
 - Internal PLL up to 96 MHz
 - Real-time clock provides calendar functions, tamper, and wake-up functions
 - Reset Supervisor monitors supply voltage, watchdog, wake-up unit, external reset
 - Brown-out monitor
 - Run, Idle, and Sleep Mode as low as 50 uA
- Vectored interrupt controller (VIC)
 - 32 IRQ vectors, 30 interrupt pins
 - Branch cache minimizes interrupt latency
- 8-channel, 10-bit A/D converter (ADC)
 - 0 to 3.6 V range, 0.7 usec conversion
- 10 Communication interfaces
 - 10/100 Ethernet MAC with DMA and MII
 - USB Full-speed (12 Mbps) slave device

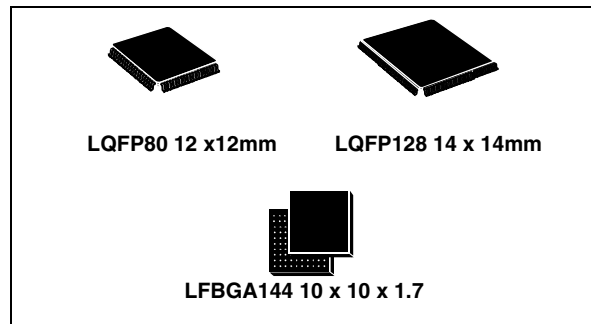

- CAN interface (2.0B Active)
- 3 16550-style UARTs with IrDA protocol
- 2 Fast I²C™, 400 kHz
- 2 channels for SPI™, SSI™, or MICROWIRE™
- External Memory Interface (EMI)
 - 8- or 16-bit data, up to 24-bit addressing
 - Static Async modes for LQFP128
 - Additional burst synchronous modes for LFBGA144
- Up to 80 I/O pins (muxed with interfaces)
- 16-bit standard timers (TIM)
 - 4 timers each with 2 input capture, 2 output compare, PWM and pulse count modes
- 3-Phase induction motor controller (IMC)
- JTAG interface with boundary scan
- Embedded trace module (ARM ETM9)

Table 1. Device summary

Reference	Part number
STR91xFAx32	STR910FAM32, STR910FAW32, STR910FAZ32, STR912FAW32
STR91xFAx42	STR911FAM42, STR911FAW42, STR912FAW42, STR912FAZ42
STR91xFAx44	STR911FAM44, STR911FAW44, STR912FAW44, STR912FAZ44
STR91xFAx46	STR911FAM46, STR911FAW46, STR912FAW46, STR912FAZ46
STR91xFAx47	STR911FAM47, STR911FAW47, STR912FAW47, STR912FAZ47

Contents

1	Description	10
2	Device summary	11
3	Functional overview	12
3.1	System-in-a-package (SiP)	12
3.2	Package choice	12
3.3	ARM966E-S CPU core	12
3.4	Burst Flash memory interface	12
3.4.1	Pre-fetch queue (PFQ)	12
3.4.2	Branch cache (BC)	13
3.4.3	Management of literals	13
3.5	SRAM (64 Kbytes or 96 Kbytes)	15
3.5.1	Arbitration	15
3.5.2	Battery backup	15
3.6	DMA data movement	15
3.7	Non-volatile memories	15
3.7.1	Primary Flash memory	16
3.7.2	Secondary Flash memory	16
3.8	One-time-programmable (OTP) memory	17
3.8.1	Product ID and revision level	17
3.9	Vectored interrupt controller (VIC)	17
3.9.1	FIQ handling	17
3.9.2	IRQ handling	18
3.9.3	Interrupt sources	18
3.10	Clock control unit (CCU)	20
3.10.1	Master clock sources	20
3.10.2	Reference clock (RCLK)	21
3.10.3	AHB clock (HCLK)	21
3.10.4	APB clock (PCLK)	21
3.10.5	Flash memory interface clock (FMICLK)	21
3.10.6	UART and SSP clock (BRCLK)	22
3.10.7	External memory interface bus clock (BCLK)	22

3.10.8	USB interface clock	22
3.10.9	Ethernet MAC clock	22
3.10.10	External RTC calibration clock	22
3.10.11	Operation example	22
3.11	Flexible power management	23
3.11.1	Run mode	23
3.11.2	Idle mode	23
3.11.3	Sleep mode	23
3.12	Voltage supplies	24
3.12.1	Independent A/D converter supply and reference voltage	24
3.12.2	Battery supply	24
3.13	System supervisor	25
3.13.1	Supply voltage brownout	25
3.13.2	Supply voltage dropout	25
3.13.3	Watchdog timer	25
3.13.4	External RESET_INn pin	26
3.13.5	Power-up	26
3.13.6	JTAG debug command	26
3.13.7	Tamper detection	26
3.14	Real-time clock (RTC)	26
3.15	JTAG interface	27
3.15.1	In-system-programming	28
3.15.2	Boundary scan	28
3.15.3	CPU debug	28
3.15.4	JTAG security bit	29
3.16	Embedded trace module (ARM ETM9, v. r2p2)	29
3.17	Ethernet MAC interface with DMA	30
3.18	USB 2.0 slave device interface with DMA	30
3.18.1	Packet buffer interface (PBI)	31
3.18.2	DMA	31
3.18.3	Suspend mode	31
3.19	CAN 2.0B interface	31
3.20	UART interfaces with DMA	32
3.20.1	DMA	32
3.21	I2C interfaces	33
3.22	SSP interfaces (SPI, SSI, and MICROWIRE) with DMA	33

3.22.1	DMA	34
3.23	General purpose I/O	34
3.24	A/D converter (ADC) with DMA	35
3.24.1	DMA	35
3.25	Standard timers (TIM) with DMA	35
3.25.1	DMA	36
3.26	Three-phase induction motor controller (IMC)	36
3.27	External memory interface (EMI)	37
4	Related documentation	41
5	Pin description	42
5.1	LFBGA144 ball connections	44
5.2	Default pin functions	45
5.2.1	General notes on pin usage	45
6	Memory mapping	53
6.1	Buffered and non-buffered writes	53
6.2	System (AHB) and peripheral (APB) buses	53
6.3	SRAM	53
6.4	Two independent Flash memories	54
6.4.1	Default configuration	54
6.4.2	Optional configuration	54
6.5	STR91xFA memory map	55
7	Electrical characteristics	57
7.1	Parameter conditions	57
7.1.1	Minimum and maximum values	57
7.1.2	Typical values	57
7.1.3	Typical curves	57
7.1.4	Loading capacitor	57
7.1.5	Pin input voltage	57
7.2	Absolute maximum ratings	58
7.3	Operating conditions	60
7.3.1	Operating conditions at power-up / power-down	60
7.4	RESET_INn and power-on-reset characteristics	61

7.5	LVD electrical characteristics	61
7.5.1	LVD delay timing	62
7.6	Supply current characteristics	63
7.6.1	Typical power consumption for frequencies below 10 MHz	64
7.7	Clock and timing characteristics	65
7.7.1	Main oscillator electrical characteristics	66
7.7.2	X1_CPU external clock source	66
7.7.3	RTC clock generated from a crystal/ceramic resonator	67
7.7.4	PLL electrical characteristics	68
7.8	Memory characteristics	68
7.8.1	SRAM characteristics	68
7.8.2	Flash memory characteristics	69
7.9	EMC characteristics	70
7.9.1	Functional EMS (electro magnetic susceptibility)	70
7.9.2	Electro magnetic interference (EMI)	71
7.9.3	Absolute maximum ratings (electrical sensitivity)	71
7.9.4	Electro-static discharge (ESD)	71
7.9.5	Static latch-up	72
7.9.6	Designing hardened software to avoid noise problems	72
7.9.7	Electrical sensitivity	72
7.10	I/O characteristics	73
7.11	External memory bus timings	74
7.11.1	Asynchronous mode	74
7.11.2	Synchronous mode	79
7.12	Communication interface electrical characteristics	82
7.12.1	10/100 Ethernet MAC electrical characteristics	82
7.12.2	USB electrical interface characteristics	84
7.12.3	CAN interface electrical characteristics	84
7.12.4	I2C electrical characteristics	85
7.12.5	SPI electrical characteristics	86
7.13	ADC electrical characteristics	88
8	Device marking	91
8.1	STR91xFAx32 / STR91xFAx42 / STR91xFAx44	91
8.2	STR91xFAx46 / STR91xFAx47	92

9	Package mechanical data	93
	9.1 ECOPACK	96
	9.2 Thermal characteristics	96
10	Ordering information	98
11	Revision history	99

List of tables

Table 1.	Device summary	1
Table 2.	Device summary	11
Table 3.	Sectoring of primary Flash memory	16
Table 4.	Sectoring of secondary Flash memory	16
Table 5.	Product ID and revision level values.	17
Table 6.	VIC IRQ channels	19
Table 7.	STR91x LFBGA144 ball connections	44
Table 8.	Device pin description.	45
Table 9.	Absolute maximum ratings	58
Table 10.	Current characteristics	59
Table 11.	Operating conditions.	60
Table 12.	Operating conditions at power-up / power-down	60
Table 13.	RESET_INn and power-on-reset characteristics	61
Table 14.	LVD electrical characteristics	61
Table 15.	Supply current characteristics.	63
Table 16.	Typical current consumption at 25 °C.	64
Table 17.	Internal clock frequencies	65
Table 18.	Main oscillator electrical characteristics	66
Table 20.	RTC oscillator electrical characteristics	67
Table 21.	RTC crystal electrical characteristics	67
Table 22.	PLL electrical characteristics	68
Table 23.	SRAM and hardware registers	68
Table 24.	Flash memory program/erase characteristics (Flash size £ 512 KB)	69
Table 25.	Flash memory program/erase characteristics (Flash size = 1 MB / 2 MB)	69
Table 26.	Flash memory endurance	70
Table 27.	EMS data	70
Table 28.	EMI data	71
Table 29.	ESD data	71
Table 30.	Static latch-up data	72
Table 31.	I/O characteristics	73
Table 32.	EMI bus clock period	74
Table 34.	EMI read operation	75
Table 35.	Mux write times	76
Table 36.	Mux read times	77
Table 37.	Page mode read times	78
Table 38.	Sync burst write times.	80
Table 39.	Sync burst read times	81
Table 40.	MII_RX_CLK and MII_TX_CLK timing table.	82
Table 41.	MDC timing table	82
Table 42.	Ethernet MII management timing table	83
Table 43.	Ethernet MII transmit timing table	83
Table 44.	Ethernet MII receive timing table	84
Table 45.	I2C electrical characteristics	85
Table 46.	SPI electrical characteristics.	86
Table 47.	General ADC electrical characteristics	88
Table 48.	ADC conversion time (silicon Rev G)	89
Table 49.	ADC conversion time (silicon Rev H and higher)	89
Table 50.	80-pin low profile quad flat package (LQFP80) mechanical data	93

Table 51.	128-pin low profile quad flat package (LQFP128) mechanical data	94
Table 52.	144-ball low profile fine pitch ball grid array package (LFBGA144) mechanical data.	95
Table 53.	Thermal characteristics.	97
Table 54.	Ordering information scheme	98
Table 55.	Document revision history	99

List of figures

Figure 1.	STR91xFA block diagram	14
Figure 2.	Clock control	21
Figure 3.	JTAG chaining inside the STR91xFA	28
Figure 4.	EMI 16-bit multiplexed connection example	39
Figure 5.	EMI 8-bit multiplexed connection example	39
Figure 6.	EMI 8-bit non-multiplexed connection example	40
Figure 7.	STR91xFAM 80-pin package pinout	42
Figure 8.	STR91xFAW 128-pin package pinout	43
Figure 9.	STR91xFA memory map	56
Figure 10.	Pin loading conditions	57
Figure 11.	Pin input voltage	58
Figure 12.	LVD reset delay case 1	62
Figure 13.	LVD reset delay case 2	62
Figure 14.	LVD reset delay case 3	62
Figure 15.	Sleep mode current vs temperature with LVD on	64
Figure 16.	Typical application with an external clock source	66
Figure 17.	Typical application with a 32.768 kHz crystal	68
Figure 18.	Non-mux write timings	74
Figure 19.	Non-mux bus read timings	75
Figure 20.	Mux write diagram	76
Figure 21.	Mux read diagram	77
Figure 22.	Page mode read diagram	78
Figure 23.	Sync burst write diagram	79
Figure 24.	Sync burst read diagram	81
Figure 25.	MII_RX_CLK and MII_TX_CLK timing diagram	82
Figure 26.	MDC timing diagram	82
Figure 27.	Ethernet MII management timing diagram	83
Figure 28.	Ethernet MII transmit timing diagram	83
Figure 29.	Ethernet MII receive timing diagram	84
Figure 30.	SPI slave timing diagram with CPHA=0	86
Figure 31.	SPI slave timing diagram with CPHA=1	87
Figure 32.	SPI master timing diagram	87
Figure 33.	ADC conversion characteristics	90
Figure 34.	Device marking for revision G LQFP80 and LQFP128 packages	91
Figure 35.	Device marking for revision G LFBGA144 packages	91
Figure 36.	Device marking for revision H LQFP80 and LQFP128 packages	91
Figure 37.	Device marking for revision H LFBGA144 packages	91
Figure 38.	Device marking for revision A LQFP80 and LQFP128 packages	92
Figure 39.	Device marking for revision A LFBGA144 packages	92
Figure 40.	80-pin low profile quad flat package (LQFP80) outline	93
Figure 41.	128-pin low profile quad flat package (LQFP128) outline	94
Figure 42.	144-ball low profile fine pitch ball grid array package (LFBGA144) outline	95
Figure 43.	Recommended PCB design rules (0.80/0.75 mm pitch BGA)	96

1 Description

STR91xFA is a series of ARM-powered microcontrollers which combines a 16/32-bit ARM966E-S RISC processor core, dual-bank Flash memory, large SRAM for data or code, and a rich peripheral set to form an ideal embedded controller for a wide variety of applications such as point-of-sale terminals, industrial automation, security and surveillance, vending machines, communication gateways, serial protocol conversion, and medical equipment. The ARM966E-S core can perform single-cycle DSP instructions, good for speech processing, audio algorithms, and low-end imaging.

This datasheet provides STR91xFA ordering information, functional overview, mechanical information, and electrical device characteristics.

For complete information on STR91xFA memory, registers, and peripherals, please refer to the STR91xFA Reference Manual.

For information on programming the STR91xFA Flash memory please refer to the STR9 Flash Programming Reference Manual.

For information on the ARM966E-S core, please refer to the ARM966E-S Rev. 2 Technical Reference Manual.



2 Device summary

Table 2. Device summary

Part number	Flash KB	RAM KB	Major peripherals	Package
STR910FAM32	256+32	64	CAN, 40 I/Os	LQFP80, 12x12 mm
STR910FAW32	256+32	64	CAN, EMI, 80 I/Os	LQFP128, 14x14 mm
STR910FAZ32	256+32	64	CAN, EMI, 80 I/Os	LFBGA144 10 x 10 x 1.7
STR911FAM42	256+32	96	USB, CAN, 40 I/Os	LQFP80, 12x12mm
STR911FAM44	512+32	96		
STR911FAM46	1024+128	96	USB, CAN, 40 I/Os	LQFP80, 12x12mm
STR911FAM47	2048+128	96		
STR911FAW42	256+32	96	USB, CAN, EMI, 80 I/Os	LQFP128, 14x14mm
STR911FAW44	512+32	96		
STR911FAW46	1024+128	96	USB, CAN, EMI, 80 I/Os	LQFP128, 14x14mm
STR911FAW47	2048+128	96		
STR912FAW32	256+32	64	Ethernet, USB, CAN, EMI, 80 I/Os	LQFP128
STR912FAW42	256+32	96	Ethernet, USB, CAN, EMI, 80 I/Os	LQFP128
STR912FAW44	512+32	96		
STR912FAW46	1024+128	96	Ethernet, USB, CAN, EMI, 80 I/Os	LQFP128
STR912FAW47	2048+128	96		
STR912FAZ42	256+32	96	Ethernet, USB, CAN, EMI, 80 I/Os	LFBGA144 10 x 10 x 1.7
STR912FAZ44	512+32	96		
STR912FAZ46	1024+128	96	Ethernet, USB, CAN, EMI, 80 I/Os	LFBGA144 10 x 10 x 1.7
STR912FAZ47	2048+128	96		

3 Functional overview

3.1 System-in-a-package (SiP)

The STR91xFA is a SiP device, comprised of two stacked die. One die is the ARM966E-S CPU with peripheral interfaces and analog functions, and the other die is the burst Flash. The two die are connected to each other by a custom high-speed 32-bit burst memory interface and a serial JTAG test/programming interface.

3.2 Package choice

STR91xFA devices are available in 128-pin (14 x 14 mm) and 80-pin (12 x 12 mm) LQFP and LFBGA144 (10 x 10 mm) packages. Refer to [Table 2: Device summary on page 11](#) for a list of available peripherals for each of the package choices.

3.3 ARM966E-S CPU core

The ARM966E-S core inherently has separate instruction and data memory interfaces (Harvard architecture), allowing the CPU to simultaneously fetch an instruction, and read or write a data item through two Tightly-Coupled Memory (TCM) interfaces as shown in [Figure 1](#). The result is streamlined CPU Load and Store operations and a significant reduction in cycle count per instruction. In addition to this, a 5-stage pipeline is used to increase the amount of operational parallelism, giving the most performance out of each clock cycle.

Ten DSP-enhanced instruction extensions are supported by this core, including single-cycle execution of 32x16 Multiply-Accumulate, saturating addition/subtraction, and count leading-zeros.

The ARM966E-S core is binary compatible with 32-bit ARM7 code and 16-bit Thumb® code.

3.4 Burst Flash memory interface

A burst Flash memory interface ([Figure 1](#)) has been integrated into the Instruction TCM (I-TCM) path of the ARM966E-S core. Also in this path is an 8-instruction Pre-Fetch Queue (PFQ) and a 15-entry Branch Cache (BC), enabling the ARM966E-S core to perform up to 96 MIPS while executing code directly from Flash memory. This architecture provides high performance levels without a costly instruction SRAM, instruction cache, or external SDRAM. Eliminating the instruction cache also means interrupt latency is reduced and code execution becomes more deterministic.

3.4.1 Pre-fetch queue (PFQ)

As the CPU core accesses sequential instructions through the I-TCM, the PFQ always looks ahead and will pre-fetch instructions, taking advantage any idle bus cycles due to variable length instructions. The PFQ will fetch 32-bits at a time from the burst Flash memory at a rate of up to 96 MHz.

3.4.2 Branch cache (BC)

When instruction addresses are not sequential, such as a program branch situation, the PFQ would have to flush and reload which would cause the CPU to stall if no BC were present. Before reloading, the PFQ checks the BC to see if it contains the desired target branch address. The BC contains up to fifteen of the most recently taken branch addresses and the first eight instructions associated with each of these branches. This check is extremely fast, checking all fifteen BC entries simultaneously for a branch address match (cache hit). If there is a hit, the BC rapidly supplies the instruction and reduces the CPU stall. This gives the PFQ time to start pre-fetching again while the CPU consumes these eight instructions from the BC. The advantage here is that program loops (very common with embedded control applications) run very fast if the address of the loops are contained in the BC.

In addition, there is a 16th branch cache entry that is dedicated to the Vectored Interrupt Controller (VIC) to further reduce interrupt latency by eliminating the stall latency typically imposed by fetching the instruction that reads the interrupt vector address from the VIC.

3.4.3 Management of literals

Typical ARM architecture and compilers do not place literals (data constants) sequentially in Flash memory with the instructions that use them, but instead the literals are placed at some other address which looks like a program branch from the PFQ's point of view. The STR91xFA implementation of the ARM966E-S core has special circuitry to prevent flushing the PFQ when literals are encountered in program flow to keep performance at a maximum.

Figure 1. STR91xFA block diagram

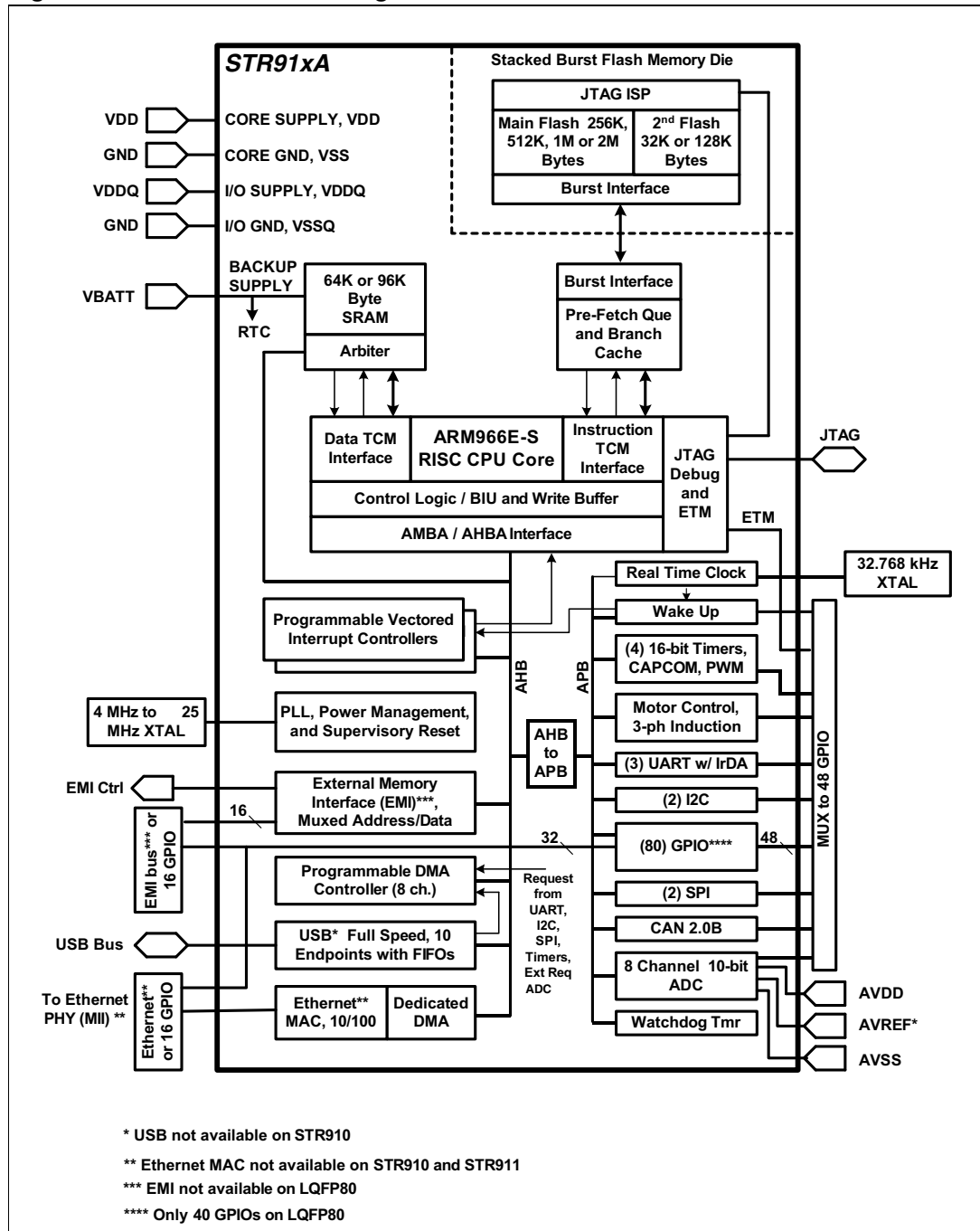

3.5 SRAM (64 Kbytes or 96 Kbytes)

A 32-bit wide SRAM resides on the CPU's Data TCM (D-TCM) interface, providing single-cycle data accesses. As shown in [Figure 1](#), the D-TCM shares SRAM access with the Advanced High-performance Bus (AHB). Sharing is controlled by simple arbitration logic to allow the DMA unit on the AHB to also access the SRAM.

3.5.1 Arbitration

Zero-wait state access occurs for either the D-TCM or the AHB when only one of the two is requesting SRAM. When both request SRAM simultaneously, access is granted on an interleaved basis so neither requestor is starved, granting one 32-bit word transfer to each requestor before relinquishing SRAM to the other. When neither the D-TCM or the AHB are requesting SRAM, the arbiter leaves access granted to the most recent user (if D-TCM was last to use SRAM then the D-TCM will not have to arbitrate to get access next time).

The CPU may execute code from SRAM through the AHB. There are no wait states as long as the D-TCM is not contending for SRAM access and the AHB is not sharing bandwidth with peripheral traffic. The ARM966E-S CPU core has a small pre-fetch queue built into this instruction path through the AHB to look ahead and fetch instructions during idle bus cycles.

3.5.2 Battery backup

When a battery is connected to the designated battery backup pin (VBATT), SRAM contents are automatically preserved when the operating voltage on the main digital supplies (VDD and VDDQ) are lost or sag below the LVD threshold. Automatic switchover to SRAM can be disabled by firmware if it is desired that the battery will power only the RTC and not the SRAM during standby.

3.6 DMA data movement

DMA channels on the Advanced High-performance Bus (AHB) take full advantage of the separate data path provided by the Harvard architecture, moving data rapidly and largely independent of the instruction path. There are two DMA units, one is dedicated to move data between the Ethernet interface and SRAM, the other DMA unit has eight programmable channels with 14 request signals to service other peripherals and interfaces (USB, SSP, ADC, UART, Timers, EMI, and external request pins). Both single word and burst DMA transfers are supported. Memory-to-memory transfers are supported in addition to memory-peripheral transfers. DMA access to SRAM is shared with D-TCM accesses, and arbitration is described in [Section 3.5.1](#). Efficient DMA transfers are managed by firmware using linked list descriptor tables. Of the 16 DMA request signals, two are assigned to external inputs. The DMA unit can move data between external devices and resources inside the STR91xFA through the EMI bus.

3.7 Non-volatile memories

There are two independent 32-bit wide burst Flash memories enabling true read-while-write operation. The Flash memories are single-voltage erase/program with 20 year minimum data retention and 100K minimum erase cycles. The primary Flash memory is much larger than the secondary Flash.

Both Flash memories are blank when devices are shipped from ST. The CPU can boot only from Flash memory (configurable selection of which Flash bank).

Flash memories are programmed half-word (16 bits) at a time, but are erased by sector or by full array.

3.7.1 Primary Flash memory

Using the STR91xFA device configuration software tool and 3rd party Integrated Developer Environments, it is possible to specify that the primary Flash memory is the default memory from which the CPU boots at reset, or otherwise specify that the secondary Flash memory is the default boot memory. This choice of boot memory is non-volatile and stored in a location that can be programmed and changed only by JTAG In-System Programming. See [Section 6: Memory mapping](#), for more detail.

The primary Flash memory has equal length 64K byte sectors. See [Table 3](#) for number of sectors per device type.

Table 3. Sectoring of primary Flash memory

Size of primary Flash	256 Kbytes	512 Kbytes	1 Mbyte	2 Mbytes
Number of sectors	4	8	16	32
Size of each sector	64 Kbytes		64 Kbytes	

3.7.2 Secondary Flash memory

The smaller of the two Flash memories can be used to implement a bootloader, capable of storing code to perform robust In-Application Programming (IAP) of the primary Flash memory. The CPU executes code from the secondary Flash, while updating code in the primary Flash memory. New code for the primary Flash memory can be downloaded over any of the interfaces on the STR91xFA (USB, Ethernet, CAN, UART, etc.)

Additionally, the secondary Flash memory may also be used to store small data sets by emulating EEPROM through firmware, eliminating the need for external EEPROM memories. This raises the data security level because passcodes and other sensitive information can be securely locked inside the STR91xFA device.

The secondary Flash memory is sectored as shown in [Table 4](#) according to device type.

Both the primary Flash memory and the secondary Flash memory can be programmed with code and/or data using the JTAG In-System Programming (ISP) channel, totally independent of the CPU. This is excellent for iterative code development and for manufacturing.

Table 4. Sectoring of secondary Flash memory

Size of secondary Flash	32 Kbytes	128 Kbytes
Number of sectors	4	8
Size of each sector	8 Kbytes	16 Kbytes

3.8 One-time-programmable (OTP) memory

There are 32 bytes of OTP memory ideally suited for serial numbers, security keys, factory calibration constants, or other permanent data constants. These OTP data bytes can be programmed only one time through either the JTAG interface or by the CPU, and these bytes can never be altered afterwards. As an option, a “lock bit” can be set by the JTAG interface or the CPU which will block any further writing to the this OTP area. The “lock bit” itself is also OTP. If the OTP array is unlocked, it is always possible to go back and write to an OTP byte location that has not been previously written, but it is never possible to change an OTP byte location if any one bit of that particular byte has been written before. The last two OTP bytes (bytes 31 and 30) are reserved for the STR91xFA product ID and revision level.

3.8.1 Product ID and revision level

OTP bytes 31 and 30 are programmed at ST factory before shipment and may be read by firmware to determine the STR91xFA product type and silicon revision so it can optionally take action based on the silicon on which it is running. In Rev H devices and 1MB/2MB Rev A devices, byte 31 contains the major family identifier of "9" (for STR9) in the high-nibble location and the minor family identifier in the low nibble location, which can be used to determine the size of primary flash memory. In all devices, byte 30 contains the silicon revision level indicator. See [Table 5](#) for values related to the revisions of STR9 production devices and size of primary Flash memory. See [Section 8](#) for details of external identification of silicon revisions.

Table 5. Product ID and revision level values

Production salestype	Silicon revision	Size of primary Flash	OTP byte 31	OTP byte 30
STR91xFAxxxxx	Rev G	256K or 512K	91h	20h
STR91xFAxxxxx	Rev H	256K	90h	21h
STR91xFAxxxxx	Rev H	512K	91h	21h
STR91xFAx46xx	Rev A	1024K	92h	21h
STR91xFAx47xx	Rev A	2048K	93h	21h

3.9 Vectored interrupt controller (VIC)

Interrupt management in the STR91xFA is implemented from daisy-chaining two standard ARM VIC units. This combined VIC has 32 prioritized interrupt request channels and generates two interrupt output signals to the CPU. The output signals are FIQ and IRQ, with FIQ having higher priority.

3.9.1 FIQ handling

FIQ (Fast Interrupt reQuest) is the only non-vectored interrupt and the CPU can execute an Interrupt Service Routine (ISR) directly without having to determine/prioritize the interrupt source, minimizing ISR latency. Typically only one interrupt source is assigned to FIQ. An FIQ interrupt has its own set of banked registers to minimize the time to make a context switch. Any of the 32 interrupt request input signals coming into the VIC can be assigned to FIQ.

3.9.2 IRQ handling

IRQ is a vectored interrupt and is the logical OR of all 32 interrupt request signals coming into the 32 IRQ channels. Priority of individual vectored interrupt requests is determined by hardware (IRQ channel Intr 0 is highest priority, IRQ channel Intr 31 is lowest).

However, inside the same VIC (primary or secondary VIC), CPU firmware may re-assign individual interrupt sources to individual hardware IRQ channels, meaning that firmware can effectively change interrupt priority levels as needed within the same VIC (from priority 0 to priority 16).

Note: *VIC0 (primary VIC) interrupts always have higher priority than VIC1 (secondary VIC) interrupts*

When the IRQ signal is activated by an interrupt request, VIC hardware will resolve the IRQ interrupt priority, then the ISR reads the VIC to determine both the interrupt source and the vector address to jump to the service code.

The STR91xFA has a feature to reduce ISR response time for IRQ interrupts. Typically, it requires two memory accesses to read the interrupt vector address from the VIC, but the STR91xFA reduces this to a single access by adding a 16th entry in the instruction branch cache, dedicated for interrupts. This 16th cache entry always holds the instruction that reads the interrupt vector address from the VIC, eliminating one of the memory accesses typically required in traditional ARM implementations.

3.9.3 Interrupt sources

The 32 interrupt request signals coming into the VIC on 32 IRQ channels are from various sources; 5 from a wake-up unit and the remaining 27 come from internal sources on the STR91xFA such as on-chip peripherals, see [Table 6](#). Optionally, firmware may force an interrupt on any IRQ channel.

One of the 5 interrupt requests generated by the wake-up unit (IRQ25 in [Table 6](#)) is derived from the logical OR of all 32 inputs to the wake-up unit. Any of these 32 inputs may be used to wake up the CPU and cause an interrupt. These 32 inputs consist of 30 external interrupts on selected and enabled GPIO pins, plus the RTC interrupt, and the USB Resume interrupt.

Each of 4 remaining interrupt requests generated by the wake-up unit (IRQ26 in [Table 6](#)) are derived from groupings of 8 interrupt sources. One group is from GPIO pins P3.2 to P3.7 plus the RTC interrupt and the USB Resume interrupt; the next group is from pins P5.0 to P5.7; the next group is from pins P6.0 to P6.7; and last the group is from pins P7.0 to P7.7. This allows individual pins to be assigned directly to vectored IRQ interrupts or one pin assigned directly to the non-vectored FIQ interrupt.

Table 6. VIC IRQ channels

IRQ channel hardware priority	VIC input channel	Logic block	Interrupt source
0 (high priority)	VIC0.0	Watchdog	Timeout in WDT mode, Terminal Count in Counter Mode
1	VIC0.1	CPU Firmware	Firmware generated interrupt
2	VIC0.2	CPU Core	Debug Receive Command
3	VIC0.3	CPU Core	Debug Transmit Command
4	VIC0.4	TIM Timer 0	Logic OR of ICI0_0, ICI0_1, OCI0_0, OCI0_1, Timer overflow
5	VIC0.5	TIM Timer 1	Logic OR of ICI1_0, ICI1_1, OCI1_0, OCI1_1, Timer overflow
6	VIC0.6	TIM Timer 2	Logic OR of ICI2_0, ICI2_1, OCI2_0, OCI2_1, Timer overflow
7	VIC0.7	TIM Timer 3	Logic OR of ICI3_0, ICI3_1, OCI3_0, OCI3_1, Timer overflow
8	VIC0.8	USB	Logic OR of high priority USB interrupts
9	VIC0.9	USB	Logic OR of low priority USB interrupts
10	VIC0.10	CCU	Logic OR of all interrupts from Clock Control Unit
11	VIC0.11	Ethernet MAC	Logic OR of Ethernet MAC interrupts via its own dedicated DMA channel.
12	VIC0.12	DMA	Logic OR of interrupts from each of the 8 individual DMA channels
13	VIC0.13	CAN	Logic OR of all CAN interface interrupt sources
14	VIC0.14	IMC	Logic OR of 8 Induction Motor Control Unit interrupts
15	VIC0.15	ADC	End of AtoD conversion interrupt
16	VIC1.0	UART0	Logic OR of 5 interrupts from UART channel 0
17	VIC1.1	UART1	Logic OR of 5 interrupts from UART channel 1
18	VIC1.2	UART2	Logic OR of 5 interrupts from UART channel 2
19	VIC1.3	I2C0	Logic OR of transmit, receive, and error interrupts of I2C channel 0
20	VIC1.4	I2C1	Logic OR of transmit, receive, and error interrupts of I2C channel 1
21	VIC1.5	SSP0	Logic OR of all interrupts from SSP channel 0
22	VIC1.6	SSP1	Logic OR of all interrupts from SSP channel 1
23	VIC1.7	BROWNOUT	LVD warning interrupt
24	VIC1.8	RTC	Logic OR of Alarm, Tamper, or Periodic Timer interrupts
25	VIC1.9	Wake-Up (all)	Logic OR of all 32 inputs of Wake-Up unit (30 pins, RTC, and USB Resume)
26	VIC1.10	Wake-up Group 0	Logic OR of 8 interrupt sources: RTC, USB Resume, pins P3.2 to P3.7
27	VIC1.11	Wake-up Group 1	Logic OR of 8 interrupts from pins P5.0 to P5.7
28	VIC1.12	Wake-up Group 2	Logic OR of 8 interrupts from pins P6.0 to P6.7

Table 6. VIC IRQ channels (continued)

IRQ channel hardware priority	VIC input channel	Logic block	Interrupt source
29	VIC1.13	Wake-up Group 3	Logic OR of 8 interrupts from pins P7.0 to P7.7
30	VIC1.14	USB	USB Bus Resume Wake-up (also input to wake-up unit)
31 (low priority)	VIC1.15	PFQ-BC	Special use of interrupts from Prefetch Queue and Branch Cache

3.10 Clock control unit (CCU)

The CCU generates a master clock of frequency f_{MSTR} . From this master clock the CCU also generates individually scaled and gated clock sources to each of the following functional blocks within the STR91xFA.

- CPU, f_{CPUCLK}
- Advanced High-performance Bus (AHB), f_{HCLK}
- Advanced Peripheral Bus (APB), f_{PCLK}
- Flash Memory Interface (FMI), f_{FMICLK}
- External Memory Interface (EMI), f_{BCLK}
- UART Baud Rate Generators, f_{BAUD}
- USB, f_{USB}

3.10.1 Master clock sources

The master clock in the CCU (f_{MSTR}) is derived from one of three clock input sources. Under firmware control, the CPU can switch between the three CCU inputs without introducing any glitches on the master clock output. Inputs to the CCU are:

- Main Oscillator (f_{OSC}). The source for the main oscillator input is a 4 to 25 MHz external crystal connected to STR91xFA pins X1_CPU and X2_CPU, or an external oscillator device connected to pin X1_CPU.
- PLL (f_{PLL}). The PLL takes the 4 to 25 MHz oscillator clock as input and generates a master clock output up to 96 MHz (programmable). By default, at power-up the master clock is sourced from the main oscillator until the PLL is ready (locked) and then the CPU may switch to the PLL source under firmware control. The CPU can switch back to the main oscillator source at any time and turn off the PLL for low-power operation. The PLL is always turned off in Sleep mode.
- RTC (f_{RTC}). A 32.768 kHz external crystal can be connected to pins X1_RTC and X2_RTC, or an external oscillator connected to pin X1_RTC to constantly run the real-time clock unit. This 32.768 kHz clock source can also be used as an input to the CCU to run the CPU in slow clock mode for reduced power.

As an option, there are a number of peripherals that do not have to receive a clock sourced from the CCU. The USB interface can receive an external clock on pin P2.7, TIM timers TIM0/ TIM1 can receive an external clock on pin P2.4, and timers TIM2/TIM3 on pin P2.5.

Figure 2. Clock control

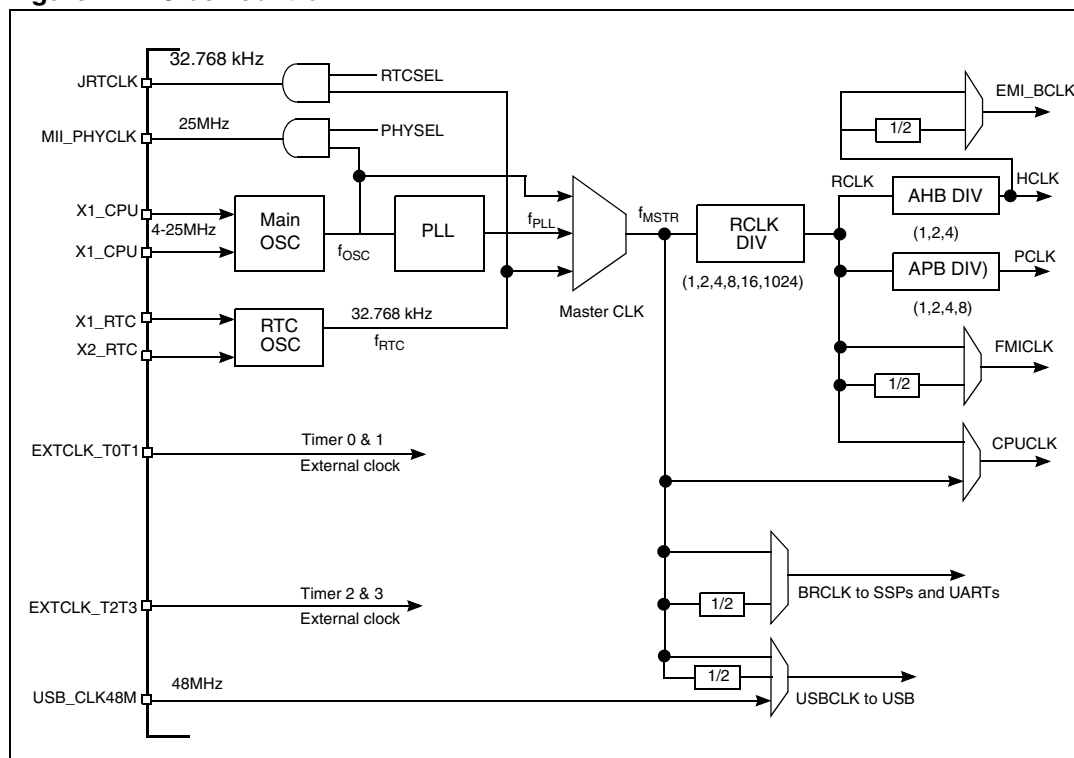

3.10.2 Reference clock (RCLK)

The main clock (f_{MSTR}) can be divided to operate at a slower frequency reference clock (RCLK) for the ARM core and all the peripherals. The RCLK provides the divided clock for the ARM core, and feeds the dividers for the AHB, APB, External Memory Interface, and FMI units.

3.10.3 AHB clock (HCLK)

The RCLK can be divided by 1, 2 or 4 to generate the AHB clock. The AHB clock is the bus clock for the AHB bus and all bus transfers are synchronized to this clock. The maximum HCLK frequency is 96 MHz.

3.10.4 APB clock (PCLK)

The RCLK can be divided by 1, 2, 4 or 8 to generate the APB clock. The APB clock is the bus clock for the APB bus and all bus transfers are synchronized to this clock. Many of the peripherals that are connected to the AHB bus also use the PCLK as the source for external bus data transfers. The maximum PCLK frequency is 48 MHz.

3.10.5 Flash memory interface clock (FMICLK)

The FMICLK clock is an internal clock derived from RCLK, defaulting to RCLK frequency at power up. The clock can be optionally divided by 2. The FMICLK determines the bus bandwidth between the ARM core and the Flash memory. Typically, codes in the Flash memory can be fetched one word per FMICLK clock in burst mode. The maximum FMICLK frequency is 96 MHz.

3.10.6 UART and SSP clock (BRCLK)

BRCLK is an internal clock derived from f_{MSTR} that is used to drive the two SSP peripherals and to generate the Baud rate for the three on-chip UART peripherals. The frequency can be optionally divided by 2.

3.10.7 External memory interface bus clock (BCLK)

The BCLK is an internal clock that controls the EMI bus. All EMI bus signals are synchronized to the BCLK. The BCLK is derived from the HCLK and the frequency can be configured to be the same or half that of the HCLK. Refer to [Table 17 on page 65](#) for the maximum BCLK frequency (f_{BCLK}). The BCLK clock is available on the LFBGA package as an output pin.

3.10.8 USB interface clock

Special consideration regarding the USB interface: The clock to the USB interface must operate at 48 MHz and comes from one of three sources, selected under firmware control:

- CCU master clock output of 48 MHz.
- CCU master clock output of 96 MHz. An optional divided-by-two circuit is available to produce 48 MHz for the USB while the CPU system runs at 96MHz.
- STR91xFA pin P2.7. An external 48 MHz oscillator connected to pin P2.7 can directly source the USB while the CCU master clock can run at some frequency other than 48 or 96 MHz.

3.10.9 Ethernet MAC clock

Special consideration regarding the Ethernet MAC: The external Ethernet PHY interface device requires it's own 25 MHz clock source. This clock can come from one of two sources:

- A 25 MHz clock signal coming from a dedicated output pin (P5.2) of the STR91xFA. In this case, the STR91xFA must use a 25 MHz signal on its main oscillator input in order to pass this 25 MHz clock back out to the PHY device through pin P5.2. The advantage here is that an inexpensive 25 MHz crystal may be used to source a clock to both the STR91xFA and the external PHY device.
- An external 25 MHz oscillator connected directly to the external PHY interface device. In this case, the STR91xFA can operate independent of 25 MHz.

3.10.10 External RTC calibration clock

The RTC_CLK can be enabled as an output on the JRTCK pin. The RTC_CLK is used for RTC oscillator calibration. The RTC_CLK is active in Sleep mode and can be used as a system wake up control clock.

3.10.11 Operation example

As an example of CCU operation, a 25 MHz crystal can be connected to the main oscillator input on pins X1_CPU and X2_CPU, a 32.768 kHz crystal connected to pins X1_RTC and X2_RTC, and the clock input of an external Ethernet PHY device is connected to STR91xFA output pin P5.2. In this case, the CCU can run the CPU at 96 MHz from PLL, the USB interface at 48 MHz, and the Ethernet interface at 25 MHz. The RTC is always running in the background at 32.768 kHz, and the CPU can go to very low power mode dynamically by running from 32.768 kHz and shutting off peripheral clocks and the PLL as needed.

3.11 Flexible power management

The STR91xFA offers configurable and flexible power management control that allows the user to choose the best power option to fit the application. Power consumption can be dynamically managed by firmware and hardware to match the system's requirements. Power management is provided via clock control to the CPU and individual peripherals.

Clocks to the CPU and peripherals can be individually divided and gated off as needed. In addition to individual clock divisors, the CCU master clock source going to the CPU, AHB, APB, EMI, and FMI can be divided dynamically by as much as 1024 for low power operation. Additionally, the CCU may switch its input to the 32.768 kHz RTC clock at any time for low power.

The STR91xFA supports the following three global power control modes:

- **Run Mode:** All clocks are on with option to gate individual clocks off via clock mask registers.
- **Idle Mode:** CPU and FMI clocks are off until an interrupt, reset, or wake-up occurs. Pre-configured clock mask registers selectively allow individual peripheral clocks to continue run during Idle Mode.
- **Sleep Mode:** All clocks off except RTC clock. Wake up unit remains powered, PLL is forced off.

A special mode is used when JTAG debug is active which never gates off any clocks even if the CPU enters Idle or Sleep mode.

3.11.1 Run mode

This is the default mode after any reset occurs. Firmware can gate off or scale any individual clock. Also available is a special Interrupt Mode which allows the CPU to automatically run full speed during an interrupt service and return back to the selected CPU clock divisor rate when the interrupt has been serviced. The advantage here is that the CPU can run at a very low frequency to conserve power until a periodic wake-up event or an asynchronous interrupt occurs at which time the CPU runs full speed immediately.

3.11.2 Idle mode

In this mode the CPU suspends code execution and the CPU and FMI clocks are turned off immediately after firmware sets the Idle Bit. Various peripherals continue to run based on the settings of the mask registers that exist just prior to entering Idle Mode. There are 3 ways to exit Idle Mode and return to Run Mode:

- Any reset (external reset pin, watchdog, low-voltage, power-up, JTAG debug command)
- Any interrupt (external, internal peripheral, RTC alarm or interval)
- Input from wake-up unit on GPIO pins

Note: It is possible to remain in Idle Mode for the majority of the time and the RTC can be programmed to periodically wake up to perform a brief task or check status.

3.11.3 Sleep mode

In this mode all clock circuits except the RTC are turned off and main oscillator input pins X1_CPU and X2_CPU are disabled. The RTC clock is required for the CPU to exit Sleep

Mode. The entire chip is quiescent (except for RTC and wake-up circuitry). There are three means to exit Sleep Mode and re-start the system:

- Some resets (external reset pin, low-voltage, power-up, JTAG debug command)
- RTC alarm
- Input from wake-up unit

3.12 Voltage supplies

The STR91xFA requires two separate operating voltage supplies. The CPU and memories operate from a 1.65V to 2.0V on the VDD pins, and the I/O ring operates at 2.7V to 3.6V on the VDDQ pins.

In Standby mode, both VDD and VDDQ must be shut down. Otherwise the specified maximum power consumption for Standby mode ($I_{\text{RTC_STBY}}$ and $I_{\text{SRAM_STBY}}$) may be exceeded. Leakage may occur if only one of the voltage supplies is off.

3.12.1 Independent A/D converter supply and reference voltage

The ADC unit on 128-pin and 144-ball packages has an isolated analog voltage supply input at pin AVDD to accept a very clean voltage source, independent of the digital voltage supplies. Additionally, an isolated analog supply ground connection is provided on pin AVSS only on 128-pin and 144-ball packages for further ADC supply isolation. On 80-pin packages, the analog voltage supply is shared with the ADC reference voltage pin (as described next), and the analog ground is shared with the digital ground at a single point in the STR91xFA device on pin AVSS_VSSQ.

A separate external analog reference voltage input for the ADC unit is available on 128-pin and 144-ball packages at the AVREF pin for better accuracy on low voltage inputs. For 80-pin packages, the ADC reference voltage is tied internally to the ADC unit supply voltage at pin AVREF_AVDD, meaning the ADC reference voltage is fixed to the ADC unit supply voltage.

See [Table 11: Operating conditions](#), for restrictions to the relative voltage levels of VDDQ, AVDD, AVREF, and AVREF_AVDD.

3.12.2 Battery supply

An optional stand-by voltage from a battery or other source may be connected to pin VBATT to retain the contents of SRAM in the event of a loss of the main digital supplies (V_{DD} and V_{DDQ}). The SRAM will automatically switch its supply from the internal V_{DD} source to the VBATT pin when the voltage of V_{DD} drops below the LVD threshold. In order to use the battery supply, the LVD must be enabled.

The VBATT pin also supplies power to the RTC unit, allowing the RTC to function even when the main digital supplies (V_{DD} and V_{DDQ}) are switched off. By configuring the RTC register, it is possible to select whether or not to power from VBATT only the RTC unit, or power the RTC unit and the SRAM when the STR91xFA device is powered off.

3.13 System supervisor

The STR91xFA monitors several system and environmental inputs and will generate a global reset, a system reset, or an interrupt based on the nature of the input and configurable settings. A global reset clears all functions on the STR91xFA, a system reset will clear all but the Clock Control Unit (CCU) settings and the system status register. At any time, firmware may reset individual on-chip peripherals. System supervisor inputs include:

- GR: CPU voltage supply (V_{DD}) drop out or brown out
- GR: I/O voltage supply (V_{DDQ}) drop out or brown out
- GR: Power-Up condition
- SR: Watchdog timer timeout
- SR: External reset pin (RESET_INn)
- SR: JTAG debug reset command

Note: GR: means the input causes Global Reset, SR: means the input causes System Reset

The CPU may read a status register after a reset event to determine if the reset was caused by a watchdog timer timeout or a voltage supply drop out. This status register is cleared only by a power up reset.

3.13.1 Supply voltage brownout

Each operating voltage source (V_{DD} and V_{DDQ}) is monitored separately by the Low Voltage Detect (LVD) circuitry. The LVD will generate an early warning interrupt to the CPU when voltage sags on either V_{DD} or V_{DDQ} voltage inputs. This is an advantage for battery powered applications because the system can perform an orderly shutdown before the batteries become too weak. The voltage trip point to cause a brown out interrupt is typically 0.25V above the LVD dropout thresholds that cause a reset.

CPU firmware may prevent all brown-out interrupts by writing to interrupt mask registers at run-time.

3.13.2 Supply voltage dropout

LVD circuitry will always cause a global reset if the CPU's V_{DD} source drops below its fixed threshold of 1.4V.

However, the LVD trigger threshold to cause a global reset for the I/O ring's V_{DDQ} source is set to one of two different levels, depending if V_{DDQ} will be operated in the range of 2.7V to 3.3V, or 3.0V to 3.6V. If V_{DDQ} operation is at 2.7V to 3.3V, the LVD dropout trigger threshold is 2.4V. If V_{DDQ} operation is 3.0V and 3.6V, the LVD threshold is 2.7V. The choice of trigger level is made by STR91xFA device configuration software from STMicroelectronics or IDE from 3rd parties, and is programmed into the STR91xFA device along with other configurable items through the JTAG interface when the Flash memory is programmed.

CPU firmware may prevent some LVD resets if desired by writing a control register at run-time. Firmware may also disable the LVD completely for lowest-power operation when an external LVD device is being used.

3.13.3 Watchdog timer

The STR91xFA has a 16-bit down-counter (not one of the four TIM timers) that can be used as a watchdog timer or as a general purpose free-running timer/counter. The clock source is the peripheral clock from the APB, and an 8-bit clock pre-scaler is available. When enabled

by firmware as a watchdog, this timer will cause a system reset if firmware fails to periodically reload this timer before the terminal count of 0x0000 occurs, ensuring firmware sanity. The watchdog function is off by default after a reset and must be enabled by firmware.

3.13.4 External RESET_INn pin

This input signal is active-low with hystereses (V_{HYS}). Other open-drain, active-low system reset signals on the circuit board (such as closure to ground from a push-button) may be connected directly to the RESET_INn pin, but an external pull-up resistor to V_{DDQ} must be present as there is no internal pullup on the RESET_INn pin.

A valid active-low input signal of t_{RINMIN} duration on the RESET_INn pin will cause a system reset within the STR91xFA. There is also a RESET_OUTn pin on the STR91xFA that can drive other system components on the circuit board. RESET_OUTn is active-low and has the same timing of the Power-On-Reset (POR) shown next, t_{POR} .

3.13.5 Power-up

The LVD circuitry will always generate a global reset when the STR91xFA powers up, meaning internal reset is active until V_{DDQ} and V_{DD} are both above the LVD thresholds. This POR condition has a duration of t_{POR} , after which the CPU will fetch its first instruction from address 0x0000.0000 in Flash memory. It is not possible for the CPU to boot from any other source other than Flash memory.

3.13.6 JTAG debug command

When the STR91xFA is in JTAG debug mode, an external device which controls the JTAG interface can command a system reset to the STR91xFA over the JTAG channel.

3.13.7 Tamper detection

On 128-pin and 144-ball STR91xFA devices only, there is a tamper detect input pin, TAMPER_IN, used to detect and record the time of a tamper event on the end product such as malicious opening of an enclosure, unwanted opening of a panel, etc. The activation mode of the tamper pin is programmable to one of two modes. One is Normally Closed/Tamper Open, the other mode will detect when a signal on the tamper input pin is driven from low-to-high, or high-to-low depending on firmware configuration. Once a tamper event occurs, the RTC time (millisecond resolution) and the date are recorded in the RTC unit. Simultaneously, the SRAM standby voltage source will be cut off to invalidate all SRAM contents. Tamper detection control and status logic are part of the RTC unit.

3.14 Real-time clock (RTC)

The RTC combines the functions of a complete time-of-day clock (millisecond resolution) with an alarm programmable up to one month, a 9999-year calendar with leap-year support, periodic interrupt generation from 1 to 512 Hz, tamper detection (described in [Section 3.13.7](#)), and an optional clock calibration output on the JRTCK pin. The time is in 24 hour mode, and time/calendar values are stored in binary-coded decimal format.

The RTC also provides a self-isolation mode that is automatically activated during power down. This feature allows the RTC to continue operation when V_{DDQ} and V_{DD} are absent, as long as an alternate power source, such as a battery, is connected to the VBATT input

pin. The current drawn by the RTC unit on the VBATT pin is very low in this standby mode, I_{RTC_STBY} .

3.15 JTAG interface

An IEEE-1149.1 JTAG interface on the STR91xFA provides In-System-Programming (ISP) of all memory, boundary scan testing of pins, and the capability to debug the CPU.

STR91xFA devices are shipped from ST with blank Flash memories. The CPU can only boot from Flash memory (selection of which Flash bank is programmable). Firmware must be initially programmed through JTAG into one of these Flash memories before the STR91xFA is used.

Six pins are used on this JTAG serial interface. The five signals JTDI, JTDO, JTMS, JTCK, and JTRSTn are all standard JTAG signals complying with the IEEE-1149.1 specification. The sixth signal, JRTCK (Return TCK), is an output from the STR91xFA and it is used to pace the JTCK clock signal coming in from the external JTAG test equipment for debugging. The frequency of the JTCK clock signal coming from the JTAG test equipment must be at least 10 times less than the ARM966E-S CPU core operating frequency (f_{CPUCLK}). To ensure this, the signal JRTCK is output from the STR91xFA and is input to the external JTAG test equipment to hold off transitions of JTCK until the CPU core is ready, meaning that the JTAG equipment cannot send the next rising edge of JTCK until the equipment receives a rising edge of JRTCK from the STR91xFA. The JTAG test equipment must be able to interpret the signal JRTCK and perform this adaptive clocking function. If it is known that the CPU clock will always be at least ten times faster than the incoming JTCK clock signal, then the JRTCK signal is not needed.

The two die inside the STR91xFA (CPU die and Flash memory die) are internally daisy-chained on the JTAG bus, see [Figure 3 on page 28](#). The CPU die has two JTAG Test Access Ports (TAPs), one for boundary scan functions and one for ARM CPU debug. The Flash memory die has one TAP for program/erase of non-volatile memory. Because these three TAPs are daisy-chained, only one TAP will converse on the JTAG bus at any given time while the other two TAPs are in BYPASS mode. The TAP positioning order within this JTAG chain is the boundary scan TAP first, followed by the ARM debug TAP, followed by the Flash TAP. All three TAP controllers are reset simultaneously by one of two methods:

- A chip-level global reset, caused only by a Power-On-Reset (POR) or a Low Voltage Detect (LVD).
- A reset command issued by the external JTAG test equipment. This can be the assertion of the JTAG JTRSTn input pin on the STR91xFA or a JTAG reset command shifted into the STR91xFA serially.

This means that chip-level system resets from watchdog time-out or the assertion of RESET_INn pin do not affect the operation of any JTAG TAP controller. Only global resets effect the TAPs.

Figure 3. JTAG chaining inside the STR91xFA

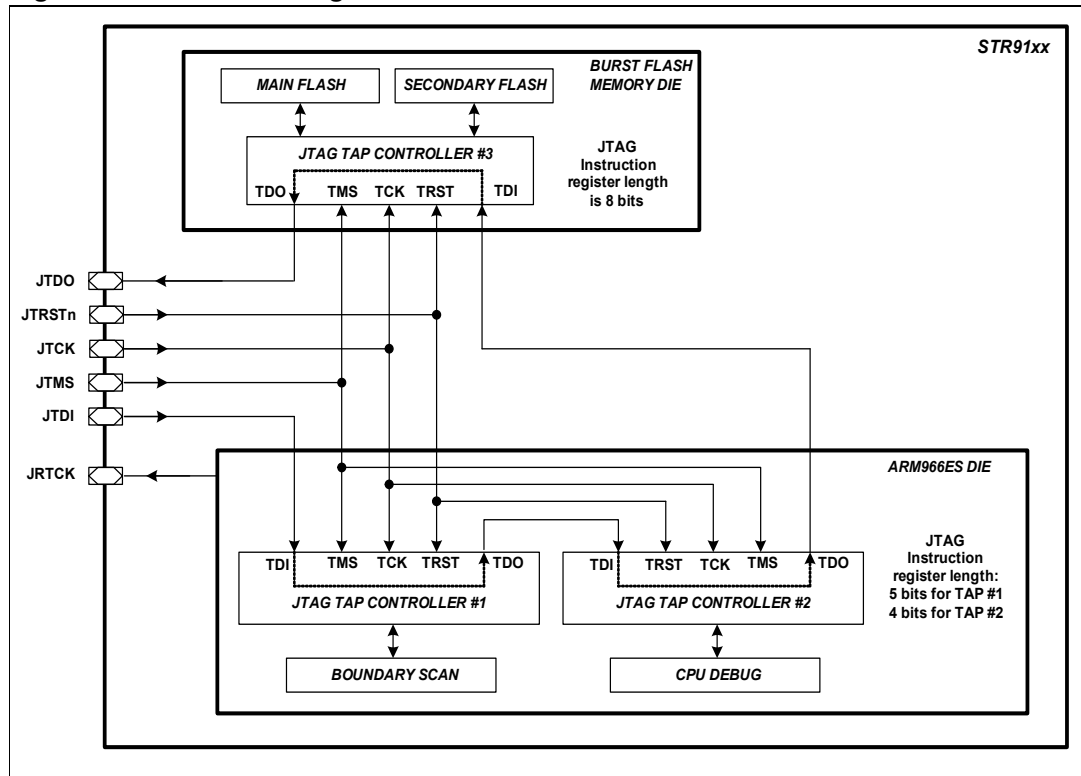

3.15.1 In-system-programming

The JTAG interface is used to program or erase all memory areas of the STR91xFA device. The pin RESET_INn must be asserted during ISP to prevent the CPU from fetching invalid instructions while the Flash memories are being programmed.

Note that the 32 bytes of OTP memory locations cannot be erased by any means once programmed by JTAG ISP or the CPU.

3.15.2 Boundary scan

Standard JTAG boundary scan testing compliant with IEEE-1149.1 is available on the majority of pins of the STR91xFA for circuit board test during manufacture of the end product. STR91xFA pins that are not serviced by boundary scan are the following:

- JTAG pins JTCK, JTMS, JTDI, JTDO, JTRSTn, JRTCK
- Oscillator input pins X1_CPU, X2_CPU, X1_RTC, X2_RTC
- Tamper detect input pin TAMPER_IN (128-pin and 144-pin packages only)

3.15.3 CPU debug

The ARM966E-S CPU core has standard ARM EmbeddedICE-RT logic, allowing the STR91xFA to be debugged through the JTAG interface. This provides advanced debugging features making it easier to develop application firmware, operating systems, and the hardware itself. Debugging requires that an external host computer, running debug software, is connected to the STR91xFA target system via hardware which converts the stream of debug data and commands from the host system's protocol (USB, Ethernet, etc.) to the

JTAG EmbeddedICE-RT protocol on the STR91xFA. These protocol converters are commercially available and operate with debugging software tools.

The CPU may be forced into a Debug State by a breakpoint (code fetch), a watchpoint (data access), or an external debug request over the JTAG channel, at which time the CPU core and memory system are effectively stopped and isolated from the rest of the system. This is known as Halt Mode and allows the internal state of the CPU core, memory, and peripherals to be examined and manipulated. Typical debug functions are supported such as run, halt, and single-step. The EmbeddedICE-RT logic supports two hardware compare units. Each can be configured to be either a watchpoint or a breakpoint. Breakpoints can also be data-dependent.

Debugging (with some limitations) may also occur through the JTAG interface while the CPU is running full speed, known as Monitor Mode. In this case, a breakpoint or watchpoint will not force a Debug State and halt the CPU, but instead will cause an exception which can be tracked by the external host computer running monitor software. Data can be sent and received over the JTAG channel without affecting normal instruction execution. Time critical code, such as Interrupt Service Routines may be debugged real-time using Monitor Mode.

3.15.4 JTAG security bit

This is a non-volatile bit (Flash memory based), which when set will not allow the JTAG debugger or JTAG programmer to read the Flash memory contents.

Using JTAG ISP, this bit is typically programmed during manufacture of the end product to prevent unwanted future access to firmware intellectual property. The JTAG Security Bit can be cleared only by a JTAG “Full Chip Erase” command, making the STR91xFA device blank (except for programmed OTP bytes), and ready for programming again. The CPU can read the status of the JTAG Security Bit, but it may not change the bit value.

3.16 Embedded trace module (ARM ETM9, v. r2p2)

The ETM9 interface provides greater visibility of instruction and data flow happening inside the CPU core by streaming compressed data at a very high rate from the STR91xFA through a small number of ETM9 pins to an external Trace Port Analyzer (TPA) device. The TPA is connected to a host computer using USB, Ethernet, or other high-speed channel. Real-time instruction flow and data activity can be recorded and later formatted and displayed on the host computer running debugger software, and this software is typically integrated with the debug software used for EmbeddedICE-RT functions such as single-step, breakpoints, etc. Tracing may be triggered and filtered by many sources, such as instruction address comparators, data watchpoints, context ID comparators, and counters. State sequencing of up to three triggers is also provided. TPA hardware is commercially available and operates with debugging software tools.

The ETM9 interface is nine pins total, four of which are data lines, and all pins can be used for GPIO after tracing is no longer needed. The ETM9 interface is used in conjunction with the JTAG interface for trace configuration. When tracing begins, the ETM9 engine compresses the data by various means before broadcasting data at high speed to the TPA over the four data lines. The most common ETM9 compression technique is to only output address information when the CPU branches to a location that cannot be inferred from the source code. This means the host computer must have a static image of the code being executed for decompressing the ETM9 data. Because of this, self-modified code cannot be traced.

3.17 Ethernet MAC interface with DMA

STR91xFA devices in 128-pin and 144-ball packages provide an IEEE-802.3-2002 compliant Media Access Controller (MAC) for Ethernet LAN communications through an industry standard Medium Independent Interface (MII). The STR91xFA requires an external Ethernet physical interface device (PHY) to connect to the physical LAN bus (twisted-pair, fiber, etc.). The PHY is connected to the STR91xFA MII port using as many as 18 signals (see pins which have signal names MII_* in [Table 8](#)).

The MAC corresponds to the OSI Data Link layer and the PHY corresponds to the OSI Physical layer. The STR91xFA MAC is responsible for:

- Data encapsulation, including frame assembly before transmission, and frame parsing/error detection during and after reception.
- Media access control, including initiation of frame transmission and recover from transmission failure.

The STR91xFA MAC includes the following features:

- Supports 10 and 100 Mbps rates
- Tagged MAC frame support (VLAN support)
- Half duplex (CSMA/CD) and full duplex operation
- MAC control sublayer (control frames) support
- 32-bit CRC generation and removal
- Several address filtering modes for physical and multicast address (multicast and group addresses)
- 32-bit status code for each transmitted or received frame
- Internal FIFOs to buffer transmit and receive frames. Transmit FIFO depth is 4 words (32 bits each), and the receive FIFO is 16 words deep.

A 32-bit burst DMA channel residing on the AHB is dedicated to the Ethernet MAC for high-speed data transfers, side-stepping the CPU for minimal CPU impact during transfers. This DMA channel includes the following features:

- Direct SRAM to MAC transfers of transmit frames with the related status, by descriptor chain
- Direct MAC to SRAM transfers of receive frames with the related status, by descriptor chain
- Open and Closed descriptor chain management

3.18 USB 2.0 slave device interface with DMA

The STR91xFA provides a USB slave controller that implements both the OSI Physical and Data Link layers for direct bus connection by an external USB host on pins USBDP and USBPN. The USB interface detects token packets, handles data transmission and reception, and processes handshake packets as required by the USB 2.0 standard.

The USB slave interface includes the following features:

- Supports USB low and full-speed transfers (12 Mbps), certified to comply with the USB 2.0 specification
- Supports isochronous, bulk, control, and interrupt endpoints
- Configurable number of endpoints allowing a mixture of up to 20 single-buffered monodirectional endpoints or up to 10 double-buffered bidirectional endpoints
- Dedicated, dual-port 2 Kbyte USB Packet Buffer SRAM. One port of the SRAM is connected by a Packet Buffer Interface (PBI) on the USB side, and the CPU connects to the other SRAM port.
- CRC generation and checking
- NRZI encoding-decoding and bit stuffing
- USB suspend resume operations

3.18.1 Packet buffer interface (PBI)

The PBI manages a set of buffers inside the 2 Kbyte Packet Buffer, both for transmission and reception. The PBI will choose the proper buffer according to requests coming from the USB Serial Interface Engine (SIE) and locate it in the Packet SRAM according to addresses pointed by endpoint registers. The PBI will also auto-increment the address after each exchanged byte until the end of packet, keeping track of the number of exchanged bytes and preventing buffer overrun. Special support is provided by the PBI for isochronous and bulk transfers, implementing double-buffer usage which ensures there is always an available buffer for a USB packet while the CPU uses a different buffer.

3.18.2 DMA

A programmable DMA channel may be assigned by CPU firmware to service the USB interface for fast and direct transfers between the USB bus and SRAM with little CPU involvement. This DMA channel includes the following features:

- Direct USB Packet Buffer SRAM to system SRAM transfers of receive packets, by descriptor chain for bulk or isochronous endpoints.
- Direct system SRAM to USB Packet Buffer SRAM transfers of transmit packets, by descriptor chain for bulk or isochronous endpoints.
- Linked-list descriptor chain support for multiple USB packets

3.18.3 Suspend mode

CPU firmware may place the USB interface in a low-power suspend mode when required, and the USB interface will automatically wake up asynchronously upon detecting activity on the USB pins.

3.19 CAN 2.0B interface

The STR91xFA provides a CAN interface complying with CAN protocol version 2.0 parts A and B. An external CAN transceiver device connected to pins CAN_RX and CAN_TX is required for connection to the physical CAN bus.

The CAN interface manages up to 32 Message Objects and Identifier Masks using a Message SRAM and a Message Handler. The Message Handler takes care of low-level CAN bus activity such as acceptance filtering, transfer of messages between the CAN bus

and the Message SRAM, handling of transmission requests, and interrupt generation. The CPU has access to the Message SRAM via the Message Handler using a set of 38 control registers.

The follow features are supported by the CAN interface:

- Bit rates up to 1 Mbps
- Disable Automatic Retransmission mode for Time Triggered CAN applications
- 32 Message Objects
- Each Message Object has its own Identifier Mask
- Programmable FIFO mode
- Programmable loopback mode for self-test operation

The CAN interface is not supported by DMA.

3.20 UART interfaces with DMA

The STR91xFA supports three independent UART serial interfaces, designated UART0, UART1, and UART2. Each interface is very similar to the industry-standard 16C550 UART device. All three UART channels support IrDA encoding/decoding, requiring only an external LED transceiver to pins UARTx_RX and UARTx_Tx for communication. One UART channel (UART0) supports full modem control signals.

UART interfaces include the following features:

- Maximum baud rate of 1.5 Mbps
- Separate FIFOs for transmit and receive, each 16 deep, each FIFO can be disabled by firmware if desired
- Programmable FIFO trigger levels between 1/8 and 7/8
- Programmable baud rate generator based on CCU master clock, or CCU master clock divided by two
- Programmable serial data lengths of 5, 6, 7, or 8 bits with start bit and 1 or 2 stop bits
- Programmable selection of even, odd, or no-parity bit generation and detection
- False start-bit detection
- Line break generation and detection
- Support of IrDA SIR ENDEC functions for data rates of up to 115.2K bps
- IrDA bit duration selection of 3/16 or low-power (1.14 to 2.23 μ sec)
- Channel UART0 supports modem control functions CTS, DCD, DSR, RTS, DTR, and RI

For your reference, only two standard 16550 UART features are not supported, 1.5 stop bits and independent receive clock.

3.20.1 DMA

A programmable DMA channel may be assigned by CPU firmware to service channels UART0 and UART1 for fast and direct transfers between the UART bus and SRAM with little CPU involvement. Both DMA single-transfers and DMA burst-transfers are supported for transmit and receive. Burst transfers require that UART FIFOs are enabled.

3.21 I²C interfaces

The STR91xFA supports two independent I2C serial interfaces, designated I2C0, and I2C1. Each interface allows direct connection to an I2C bus as either a bus master or bus slave device (firmware configurable). I2C is a two-wire communication channel, having a bi-directional data signal and a single-directional clock signal based on open-drain line drivers, requiring external pull-up resistors.

Byte-wide data is transferred between a Master device and a Slave device on two wires. More than one bus Master is allowed, but only one Master may control the bus at any given time. Data is not lost when another Master requests the use of a busy bus because I2C supports collision detection and arbitration. More than one Slave device may be present on the bus, each having a unique address. The bus Master initiates all data movement and generates the clock that permits the transfer. Once a transfer is initiated by the Master, any device that is addressed is considered a Slave. Automatic clock synchronization allows I2C devices with different bit rates to communicate on the same physical bus. A single device can play the role of Master or Slave, or a single device can be a Slave only. A Master or Slave device has the ability to suspend data transfers if the device needs more time to transmit or receive data.

Each I2C interface on the STR91xFA has the following features:

- Programmable clock supports various rates up to I2C Standard rate (100 KHz) or Fast rate (400 KHz).
- Serial I/O Engine (SIOE) takes care of serial/parallel conversion; bus arbitration; clock generation and synchronization; and handshaking
- Multi-master capability
- 7-bit or 10-bit addressing

3.22 SSP interfaces (SPI, SSI, and MICROWIRE) with DMA

The STR91xFA supports two independent Synchronous Serial Port (SSP) interfaces, designated SSP0, and SSP1. Primary use of each interface is for supporting the industry standard Serial Peripheral Interface (SPI) protocol, but also supporting the similar Synchronous Serial Interface (SSI) and MICROWIRE communication protocols.

SPI is a three or four wire synchronous serial communication channel, capable of full-duplex operation. In three-wire configuration, there is a clock signal, and two data signals (one data signal from Master to Slave, the other from Slave to Master). In four-wire configuration, an additional Slave Select signal is output from Master and received by Slave.

The SPI clock signal is a gated clock generated from the Master and regulates the flow of data bits. The Master may transmit at a variety of baud rates, up to 24 MHz

In multi-Slave operation, no more than one Slave device can transmit data at any given time. Slave selection is accomplished when a Slave's "Slave Select" input is permanently grounded or asserted active-low by a Master device. Slave devices that are not selected do not interfere with SPI activities. Slave devices ignore the clock signals and keep their data output pins in high-impedance state when not selected. The STR91xFA supports SPI multi-Master operation because it provides collision detection.

Each SSP interface on the STR91xFA has the following features:

- Full-duplex, three or four-wire synchronous transfers
- Master or Slave operation
- Programmable clock bit rate with prescaler, up to 24 MHz for Master mode and 4 MHz for Slave mode
- Separate transmit and receive FIFOs, each 16-bits wide and 8 locations deep
- Programmable data frame size from 4 to 16 bits
- Programmable clock and phase polarity
- Specifically for MICROWIRE protocol:
 - Half-duplex transfers using 8-bit control message
- Specifically for SSI protocol:
 - Full-duplex four-wire synchronous transfer
 - Transmit data pin tri-stateable when not transmitting

3.22.1 DMA

A programmable DMA channel may be assigned by CPU firmware to service each SSP channel for fast and direct transfers between the SSP bus and SRAM with little CPU involvement. Both DMA single-transfers and DMA burst-transfers are supported for transmit and receive. Burst transfers require that FIFOs are enabled.

3.23 General purpose I/O

There are up to 80 GPIO pins available on 10 I/O ports for 128-pin and 144-ball devices, and up to 40 GPIO pins on 5 I/O ports for 80-pin devices. Each and every GPIO pin by default (during and just after a reset condition) is in high-impedance input mode, and some GPIO pins are additionally routed to certain peripheral function inputs. CPU firmware may initialize GPIO pins to have alternate input or output functions as listed in [Table 8](#). At any time, the logic state of any GPIO pin may be read by firmware as a GPIO input, regardless of its reassigned input or output function.

Bit masking is available on each port, meaning firmware may selectively read or write individual port pins, without disturbing other pins on the same port during a write.

Firmware may designate each GPIO pin to have open-drain or push-pull characteristics.

All GPIO pins are 5V tolerant, meaning they can drive a voltage level up to VDDQ, and can be safely driven by a voltage up to 5V.

3.24 A/D converter (ADC) with DMA

The STR91xFA provides an eight-channel, 10-bit successive approximation analog-to-digital converter. The ADC input pins are multiplexed with other functions on Port 4 as shown in [Table 8](#). Following are the major ADC features:

- Fast conversion time, as low as 0.7 usec
- Accuracy. Integral and differential non-linearity are typically within 4 conversion counts.
- 0 to 3.6V input range. External reference voltage input pin (AVREF) available on 128-pin packages for better accuracy on low-voltage inputs. See [Table 11: Operating conditions](#), for restrictions to the relative voltage levels of VDDQ, AVDD, AVREF, and AVREF_AVDD.
- CPU Firmware may convert one ADC input channel at a time, or it has the option to set the ADC to automatically scan and convert all eight ADC input channels sequentially before signalling an end-of-conversion
- Automatic continuous conversion mode is available for any number of designated ADC input channels
- Analog watchdog mode provides automatic monitoring of any ADC input, comparing it against two programmable voltage threshold values. The ADC unit will set a flag or it will interrupt the CPU if the input voltage rises above the higher threshold, or drops below the lower threshold.
- The ADC unit goes to stand-by mode (very low-current consumption) after any reset event. CPU firmware may also command the ADC unit to stand-by mode at any time.
- ADC conversion can be started or triggered by software command as well as triggers from Timer/Counter (TIM), Motor Controller and input from external pin.

3.24.1 DMA

A programmable DMA channel may be assigned by CPU firmware to service each ADC conversion result for fast DMA single-transfer.

3.25 Standard timers (TIM) with DMA

The STR91xFA has four independent, free-running 16-bit timer/counter modules designated TIM0, TIM1, TIM2, and TIM3. Each general purpose timer/counter can be configured by firmware for a variety of tasks including; pulse width and frequency measurement (input capture), generation of waveforms (output compare and PWM), event counting, delay timing, and up/down counting.

Each of the four timer units have the following features:

- 16-bit free running timer/counter
- Internal timer/counter clock source from a programmable 8-bit prescale of the CCU PCLK clock output
- Optional external timer/counter clock source from pin P2.4 shared by TIM0/TIM1, and pin P2.5 shared by TIM2/TIM3. Frequency of these external clocks must be at least 4 times less the frequency of the internal CCU PCLK clock output.
- Two dedicated 16-bit Input Capture registers for measuring up to two input signals. Input Capture has programmable selection of input signal edge detection
- Two dedicated 16-bit Output Compare registers for generation up to two output signals
- PWM output generation with 16-bit resolution of both pulse width and frequency
- One pulse generation in response to an external event
- A dedicated interrupt to the CPU with five interrupt flags
- The OCF1 flag (Output Compare 1) from the timer can be configured to trigger an ADC conversion

3.25.1 DMA

A programmable DMA channel may be assigned by CPU firmware to service each timer/counter module TIM0 and TIM1 for fast and direct single transfers.

3.26 Three-phase induction motor controller (IMC)

The STR91xFA provides an integrated controller for variable speed motor control applications.

Six PWM outputs are generated on high current drive pins P6.0 to P6.5 for controlling a three-phase AC induction motor drive circuit assembly. Rotor speed feedback is provided by capturing a tachometer input signal on pin P6.6, and an asynchronous hardware emergency stop input is available on pin P6.7 to stop the motor immediately if needed, independently of firmware.

The IMC unit has the following features:

- Three PWM outputs generated using a 10 or 16-bit PWM counter, one for each phase U, V, W. Complimentary PWM outputs are also generated for each phase.
- Choice of classic or zero-centered PWM generation modes
- 10 or 16-bit PWM counter clock is supplied through a programmable 8-bit prescaler of the APB clock.
- Programmable 6 or 10-bit dead-time generator to add delay to each of the three complimentary PWM outputs
- 8-bit repetition counter
- Automatic rotor speed measurement with 16-bit resolution. Schmitt trigger tachometer input with programmable edge detection
- Hardware asynchronous emergency stop input
- A dedicated interrupt to CPU with eight flags
- Enhanced Motor stop output polarity configuration
- Double update option when PWM counter reaches the max and min values in Zero-centered mode
- Locking feature to prevent some control register bits from being advertently modified
- Trigger output to start an ADC conversion

3.27 External memory interface (EMI)

STR91xFA devices in 128-pin and 144-ball packages offer an external memory bus for connecting external parallel peripherals and memories. The EMI bus resides on ports 7, 8, and 9 and operates with either an 8 or 16-bit data path. The configuration of 8 or 16 bit mode is specified by CPU firmware writing to configuration registers at run-time. If the application does not use the EMI bus, then these port pins may be used for general purpose I/O as shown in [Table 8](#).

The EMI has the following features:

- Supports static asynchronous memory access cycles, including page mode for non-mux operation. The bus control signals include:
 - EMI_RDn - read signal, x8 or x16 mode
 - EMI_BWR_WRLn - write signal in x8 mode and write low byte signal in x16 mode
 - EMI_WRHn - write high byte signal in x16 mode
 - EMI_ALE - address latch signal for x8 or x16 mux bus mode with programmable polarity
- Four configurable memory regions, each with a chip select output (EMI_CS0n ... EMI_CS3n)
- Programmable wait states per memory region for both write and read operations
- **16-bit multiplexed data mode** ([Figure 4](#)): 16 bits of data and 16 bits of low-order address are multiplexed together on ports 8 and 9, while port 7 contains eight more high-order address signals. The output signal on pin EMI_ALE is used to demultiplex the signals on ports 8 and 9, and the polarity of EMI_ALE is programmable. The output signals on pins EMI_BWR_WRLn and EMI_WRHn are the write strobes for the low and

high data bytes respectively. The output signal EMI_RDn is the read strobe for both the low and high data bytes.

- **8-bit multiplexed data mode:** This is a variant of the 16-bit multiplexed mode. Although this mode can provide 24 bits of address and 8 bits of data, it does require an external latch device on Port 8. However, this mode is most efficient when connecting devices that only require 8 bits of address on an 8-bit multiplexed address/data bus, and have simple read, write, and latch inputs as shown in [Figure 5](#)

To use all 24 address bits, the following applies: 8 bits of lowest-order data and 8 bits of lowest-order address are multiplexed on port 8. On port 9, 8-bits of mid-order address are multiplexed with 8 bits of data, but these 8 data values are always at logic zero on this port during a write operation, and these 8 data bits are ignored during a read operation. An external latch device is needed to de-multiplex the mid-order 8 address bits that are generated on port 8. Port 7 outputs the 8 highest-order address signals directly (not multiplexed). The output signal on pin EMI_ALE is used to demultiplex the signals on ports 8 and 9, and the polarity of EMI_ALE is programmable. The output signal on pin EMI_BWR_WRLn is the data write strobe, and the output on pin EMI_RDn is the data read strobe.

- **8-bit non-multiplexed data mode** ([Figure 6](#)): Eight bits of data are on port 8, while 16 bits of address are output on ports 7 and 9. The output signal on pin EMI_BWR_BWLn is the data write strobe and the output on pin EMI_RDn is the data read strobe.
- **Burst Mode Support (LFBGA package only):** The EMI bus supports synchronized burst read and write bus cycle in multiplexed and non-multiplexed mode. The additional EMI signals in the LFBGA package that support the burst mode are:
 - EMI_BCLK -the bus clock output. The EMI_BCLK has the same frequency or half of that of the HCLK and can be disabled by the user
 - EMI_WAITn - the not ready or wait input signal for synchronous access
 - EMI_BAA n - burst address advance or burst enable signal
 - EMI_WEn - write enable signal
 - EMI_UBn, EMI_LBn - upper byte and lower byte enable signals. These two signals share the same pins as the EMI_WRLn and EMI_WRHn and are user configurable through the EMI register.

By defining the bus parameters such as burst length, burst type, read and write timings in the EMI control registers, the EMI bus is able to interface to standard burst memory devices. The burst timing specification and waveform will be provided in the next data sheet release

Figure 4. EMI 16-bit multiplexed connection example

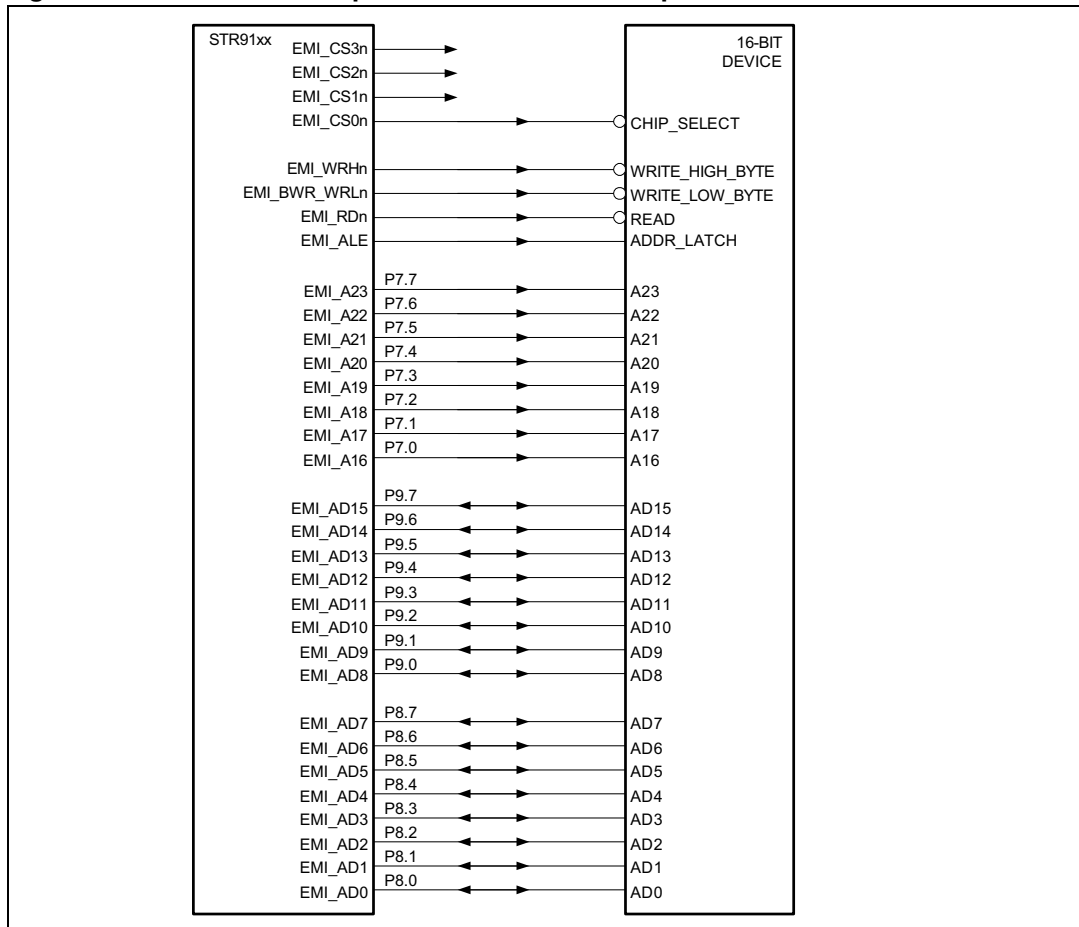

Figure 5. EMI 8-bit multiplexed connection example

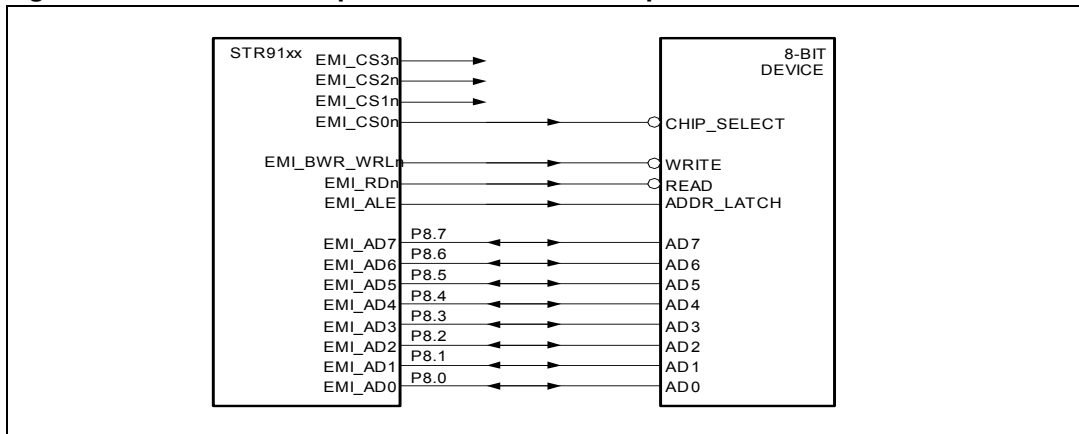
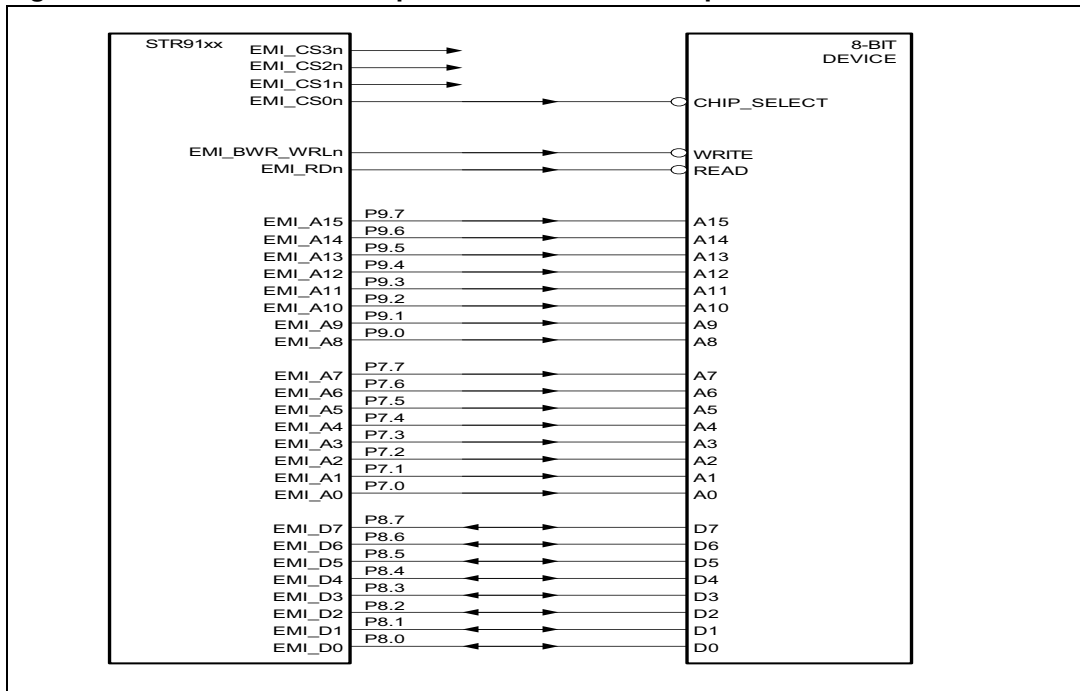

Figure 6. EMI 8-bit non-multiplexed connection example



4 Related documentation

Available from www.arm.com:

ARM966E-S Rev 2 Technical Reference Manual

Available from www.st.com:

STR91xFA reference manual

STR9 Flash programming manual (PM0020)

The above is a selected list only, a full list STR91xFA application notes can be viewed at <http://www.st.com>.

5 Pin description

Figure 7. STR91xFAM 80-pin package pinout

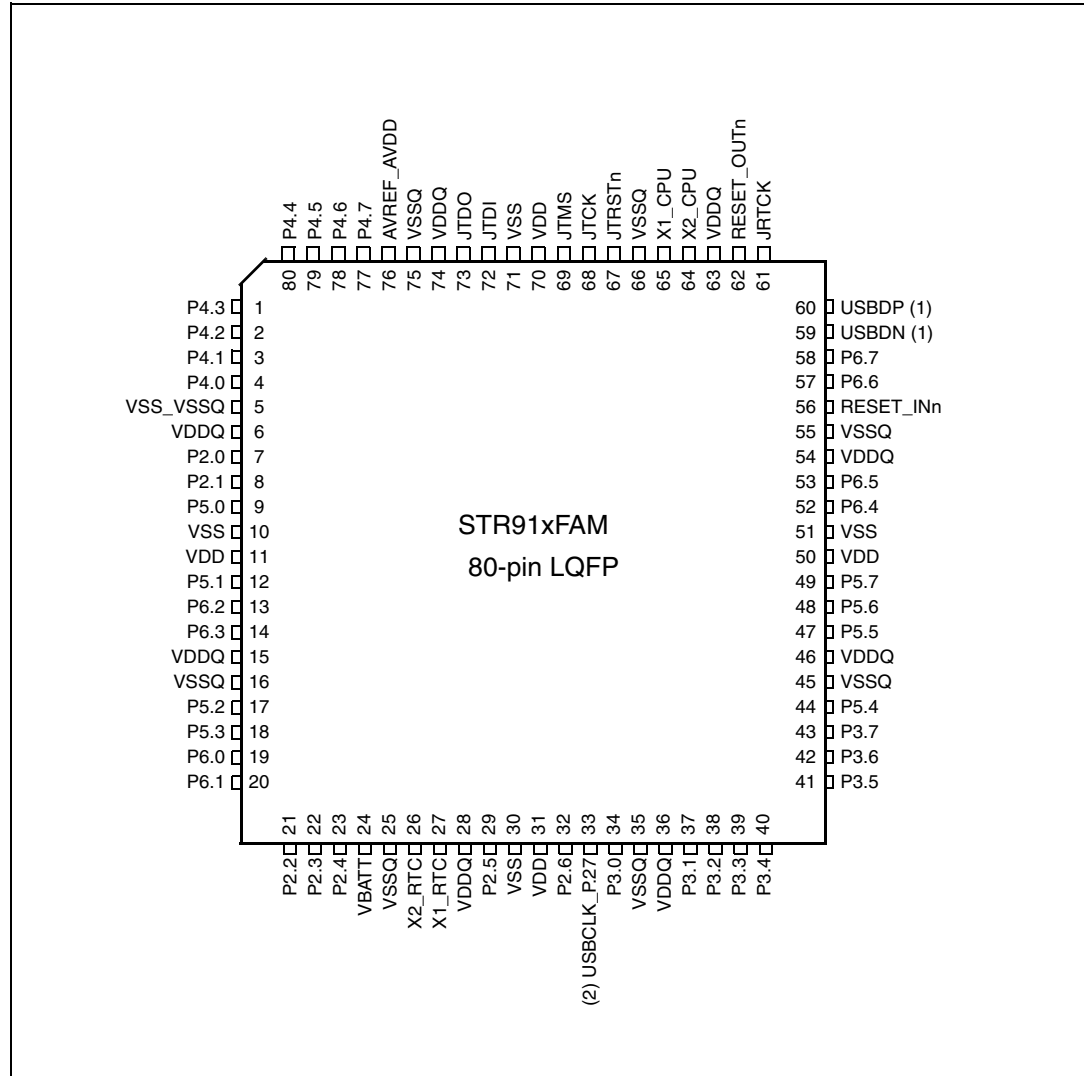

1. NU (Not Used) on STR910FAM devices. Pin 59 is not connected, pin 60 must be pulled up by a 1.5Kohm resistor to VDDQ.
2. No USBCLK function on STR910FAM devices.

5.1 LFBGA144 ball connections

- In [Table 7](#) balls labelled NC are no connect balls. These NC balls are reserved for future devices and should NOT be connected to ground or any other signal. There are total of 9 NC (no connection) balls.
- Balls H1 and G4 are assigned as EMI bus write signals (EMI_BWR_WRLn and EMI_WRHn). These two balls can also be configured by the user as EMI low or high byte select signals (EMI_LBn and EMI_UBn).
- The PLLGND (B8) and PLLVDDQ (C9) balls can be connected to VSSQ and VDDQ.

Table 7. STR91x LFBGA144 ball connections

	A	B	C	D	E	F	G	H	J	K	L	M
1	P4.2	P7.2	NC	P7.0	VDDQ	P7.3	P7.4	EMI_WRHn (EMI_UBn)	VDDQ	PHYCLK_P5.2 ⁽¹⁾	P8.0	P2.2
2	AVREF	P4.1	P4.0	P7.1	P2.0	NC	P6.2	P5.3	P8.2	P8.3	VSSQ	P8.6
3	AVDD	P4.3	AVSS	NC	P2.1	VSS	P6.3	P8.1	P6.1	P2.3	P8.4	VBATT
4	P4.6	P4.5	P4.4	VSSQ	P5.0	VDD	EMI_BWR_WRLn (EMI_LBn)	P6.0	P8.5	VSSQ	P2.4	X2_RTC
5	P7.7	VDDQ	VSSQ	P4.7	P7.5	NC	VSSQ	VSS	P2.5	P8.7	VDDQ	X1_RTC
6	JTMS	JTDO	JTDI	P1.7	P7.6	P5.1	P2.6	P9.4	P9.3	P9.2	VDD	P9.0
7	P1.5	P1.4	NC	VDD	VSS	P1.6	P6.5	VDDQ	VSSQ	P3.0	USBCLK_P2.7 ⁽²⁾	P9.1
8	VSSQ	PLLVSSQ	P1.3	JRSTn	JTCK	VSSQ	P6.4	EMI_BAA_n	P3.3	EMI_WAI_Tn	P9.5	EMI_BCLK
9	RESET_OUTn	P1.2	PLLVDDQ	VDDQ	P6.6	VDDQ	NC	P5.6	EMI_RDn	P9.7	P3.4	P9.6
10	X1_CPU	P1.0	P1.1	USBDN ⁽³⁾	TAMPER_IN	NC	VSS	P0.4	EMI_ALE	P0.1	P3.5	P3.1
11	X2_CPU	JRTCK	USBDP ⁽²⁾	MII_MDI_O ⁽³⁾	P0.6	P0.5	VDD	P5.5	P0.2	P3.7	P0.0	P3.2
12	EMI_WEn	P0.7	RESET_I_Nn	P6.7	NC	NC	P5.7	P0.3	P5.4	VDDQ	VSSQ	P3.6

1. No PHYCLK function on STR910FAW devices.

2. No USBCLK function on STR910FAW devices.

3. NU (Not Used) on STR910FAW devices. D10 is not connected, C11 must be pulled up by a 1.5 kOhm resistor to VDDQ.

5.2 Default pin functions

During and just after reset, all pins on ports 0-9 default to high-impedance input mode until CPU firmware assigns other functions to the pins. This initial input mode routes all pins on ports 0-9 to be read as GPIO inputs as shown in the “Default Pin Function” column of [Table 8](#). Simultaneously, certain port pin signals are also routed to other functional inputs as shown in the “Default Input Function” column of [Table 8](#), and these pin input functions will remain until CPU firmware makes other assignments. At any time, even after the CPU assigns pins to alternate functions, the CPU may always read the state of any pin on ports 0-9 as a GPIO input. CPU firmware may assign alternate functions to port pins as shown in columns “Alternate Input 1” or “Alternate Output 1, 2, 3” of [Table 8](#) by writing to control registers at run-time.

5.2.1 General notes on pin usage

- 1 *Since there are no internal or programmable pull-up resistors on ports 0-9, it is advised to pull down to ground, or pull up to VDDQ (using max. 47 KΩ resistors), all unused pins on port 0-9. Another solution is to use the GPIO control registers to configure the unused pins on ports 0-9 as output low level. The purpose of this is to reduce noise susceptibility, noise generation, and minimize power consumption*
- 2 *All pins on ports 0 - 9 are 5V tolerant*
- 3 *Pins on ports 0,1,2,4,5,7,8,9 have 4 mA drive and 4mA sink. Ports 3 and 6 have 8 mA drive and 8 mA sink.*
- 4 *For 8-bit non-muxed EMI operation: Port 8 is eight bits of data, ports 7 and 9 are 16 bits of address.*
- 5 *For 16-bit muxed EMI operation: Ports 8 and 9 are 16 bits of muxed address and data bits, port 7 is up to eight additional bits of high-order address*
- 6 *Signal polarity is programmable for interrupt request inputs, EMI_ALE, timer input capture inputs and output compare/PWM outputs, motor control tach and emergency stop inputs, and motor control phase outputs.*
- 7 *HiZ = High Impedance, V = Voltage Source, G = Ground, I/O = Input/Output*
- 8 *STR910FA devices do not support USB. On these devices USBDP and USBDM signals are "Not Used" (USBDM is not connected, USBDP must be pulled up by a 1.5K ohm resistor to VDDQ), and all functions named "USB" are not available.*
- 9 *STR910FA 128-pin and 144-ball devices do not support Ethernet. On these devices PHYCLK and all functions named "MII*" are not available.*

Table 8. Device pin description

Package			Pin name	Signal type	Default pin function	Default input function	Alternate functions			
LQFP80	LQFP128	LFPGA144					Alternate input 1	Alternate output 1	Alternate output 2	Alternate output 3
-	67	L11	P0.0	I/O	GPIO_0.0, GP Input, HiZ	MII_TX_CLK, PHY Xmit clock	I2C0_CLKIN, I2C clock in	GPIO_0.0, GP Output	I2C0_CLKOUT, I2C clock out	ETM_PCK0, ETM Packet
-	69	K10	P0.1	I/O	GPIO_0.1, GP Input, HiZ	-	I2C0_DIN, I2C data in	GPIO_0.1, GP Output	I2C0_DOUT, I2C data out	ETM_PCK1, ETM Packet
-	71	J11	P0.2	I/O	GPIO_0.2, GP Input, HiZ	MII_RXD0, PHY Rx data0	I2C1_CLKIN, I2C clock in	GPIO_0.2, GP Output	I2C1_CLKOUT, I2C clock out	ETM_PCK2, ETM Packet

Table 8. Device pin description (continued)

Package			Pin name	Signal type	Default pin function	Default input function	Alternate functions			
LQFP80	LQFP128	LFPGA144					Alternate input 1	Alternate output 1	Alternate output 2	Alternate output 3
-	76	H12	P0.3	I/O	GPIO_0.3, GP Input, HiZ	MII_RXD1, PHY Rx data	I2C1_DIN, I2C data in	GPIO_0.3, GP Output	I2C1_DOUT, I2C data out	ETM_PCK3, ETM Packet
-	78	H10	P0.4	I/O	GPIO_0.4, GP Input, HiZ	MII_RXD2, PHY Rx data	TIM0_ICAP1, Input Capture	GPIO_0.4, GP Output	EMI_CS0n, EMI Chip Select	ETM_PSTAT0, ETM pipe status
-	85	F11	P0.5	I/O	GPIO_0.5, GP Input, HiZ	MII_RXD3, PHY Rx data	TIM0_ICAP2, Input Capture	GPIO_0.5, GP Output	EMI_CS1n, EMI Chip Select	ETM_PSTAT1, ETM pipe status
-	88	E11	P0.6	I/O	GPIO_0.6, GP Input, HiZ	MII_RX_CLK, PHY Rx clock	TIM2_ICAP1, Input Capture	GPIO_0.6, GP Output	EMI_CS2n, EMI Chip Select	ETM_PSTAT2, ETM pipe status
-	90	B12	P0.7	I/O	GPIO_0.7, GP Input, HiZ	MII_RX_DV, PHY data valid	TIM2_ICAP2, Input Capture	GPIO_0.7, GP Output	EMI_CS3n, EMI Chip Select	ETM_TRSYNC, ETM trace sync
-	98	B10	P1.0	I/O	GPIO_1.0, GP Input, HiZ	MII_RX_ER, PHY rcv error	ETM_EXTRIG, ETM ext. trigger	GPIO_1.0, GP Output	UART1_TX, UART xmit data	SSP1_SCLK, SSP mstr clk out
-	99	C10	P1.1	I/O	GPIO_1.1, GP Input, HiZ	-	UART1_RX, UART rcv data	GPIO_1.1, GP Output	MII_TXD0, MAC Tx data	SSP1_MOSI, SSP mstr dat out
-	101	B9	P1.2	I/O	GPIO_1.2, GP Input, HiZ	-	SSP1_MISO, SSP mstr data in	GPIO_1.2, GP Output	MII_TXD1, MAC Tx data	UART0_TX, UART xmit data
-	106	C8	P1.3	I/O	GPIO_1.3, GP Input, HiZ	-	UART2_RX, UART rcv data	GPIO_1.3, GP Output	MII_TXD2, MAC Tx data	SSP1_NSS, SSP mstr sel out
-	109	B7	P1.4	I/O	GPIO_1.4, GP Input, HiZ	-	I2C0_CLKIN, I2C clock in	GPIO_1.4, GP Output	MII_TXD3, MAC Tx data	I2C0_CLKOUT, I2C clock out
-	110	A7	P1.5	I/O	GPIO_1.5, GP Input, HiZ	MII_COL, PHY collision	CAN_RX, CAN rcv data	GPIO_1.5, GP Output	UART2_TX, UART xmit data	ETM_TRCLK, ETM trace clock
-	114	F7	P1.6	I/O	GPIO_1.6, GP Input, HiZ	MII_CRS, PHY carrier sns	I2C0_DIN, I2C data in	GPIO_1.6, GP Output	CAN_TX, CAN Tx data	I2C0_DOUT, I2C data out
-	116	D6	P1.7	I/O	GPIO_1.7, GP Input, HiZ	-	ETM_EXTRIG, ETM ext. trigger	GPIO_1.7, GP Output	MII_MDC, MAC mgt dat ck	ETM_TRCLK, ETM trace clock
7	10	E2	P2.0	I/O	GPIO_2.0, GP Input, HiZ	UART0_CTS, Clear To Send	I2C0_CLKIN, I2C clock in	GPIO_2.0, GP Output	I2C0_CLKOUT, I2C clock out	ETM_PCK0, ETM Packet
8	11	E3	P2.1	I/O	GPIO_2.1, GP Input, HiZ	UART0_DSR, Data Set Ready	I2C0_DIN, I2C data in	GPIO_2.1, GP Output	I2C0_DOUT, I2C data out	ETM_PCK1, ETM Packet
21	33	M1	P2.2	I/O	GPIO_2.2, GP Input, HiZ	UART0_DCD, Dat Carrier Det	I2C1_CLKIN, I2C clock in	GPIO_2.2, GP Output	I2C1_CLKOUT, I2C clock out	ETM_PCK2, ETM Packet
22	35	K3	P2.3	I/O	GPIO_2.3, GP Input, HiZ	UART0_RI, Ring Indicator	I2C1_DIN, I2C data in	GPIO_2.3, GP Output	I2C1_DOUT, I2C data out	ETM_PCK3, ETM Packet
23	37	L4	P2.4	I/O	GPIO_2.4, GP Input, HiZ	EXTCLK_T0T1E xt clk timer0/1	SSP0_SCLK, SSP slv clk in	GPIO_2.4, GP Output	SSP0_SCLK, SSP mstr clk out	ETM_PSTAT0, ETM pipe status
29	45	J5	P2.5	I/O	GPIO_2.5, GP Input, HiZ	EXTCLK_T2T3E xt clk timer2/3	SSP0_MOSI, SSP slv dat in	GPIO_2.5, GP Output	SSP0_MOSI, SSP mstr dat out	ETM_PSTAT1, ETM pipe status
32	53	G6	P2.6	I/O	GPIO_2.6, GP Input, HiZ	-	SSP0_MISO, SSP mstr data in	GPIO_2.6, GP Output	SSP0_MISO, SSP slv data out	ETM_PSTAT2, ETM pipe status
33	54	L7	USBCLK_P2.7	I/O	GPIO_2.7, GP Input, HiZ	USB_CLK48M, 48MHz to USB	SSP0_NSS, SSP slv sel in	GPIO_2.7, GP Output	SSP0_NSS, SSP mstr sel out	ETM_TRSYNC, ETM trace sync

Table 8. Device pin description (continued)

Package			Pin name	Signal type	Default pin function	Default input function	Alternate functions			
LQFP80	LQFP128	LFBGA144					Alternate input 1	Alternate output 1	Alternate output 2	Alternate output 3
34	55	K7	P3.0	I/O	GPIO_3.0, GP Input, HiZ	DMA_RQST0, Ext DMA request	UART0_RxD, UART rcv data	GPIO_3.0, GP Output	UART2_TX, UART xmit data	TIM0_OCMP1, Out comp/PWM
37	59	M10	P3.1	I/O	GPIO_3.1, GP Input, HiZ	DMA_RQST1, Ext DMA request	UART2_RxD, UART rcv data	GPIO_3.1, GP Output	UART0_TX, UART xmit data	TIM1_OCMP1, Out comp/PWM
38	60	M11	P3.2	I/O	GPIO_3.2, GP Input, HiZ	EXINT2, External Intr	UART1_RxD, UART rcv data	GPIO_3.2, GP Output	CAN_TX, CAN Tx data	UART0_DTR, Data Trmnl Rdy
39	61	J8	P3.3	I/O	GPIO_3.3, GP Input, HiZ	EXINT3, External Intr	CAN_RX, CAN rcv data	GPIO_3.3, GP Output	UART1_TX, UART xmit data	UART0_RTS, Ready To Send
40	63	L9	P3.4	I/O	GPIO_3.4, GP Input, HiZ	EXINT4, External Intr	SSP1_SCLK, SSP slv clk in	GPIO_3.4, GP Output	SSP1_SCLK, SSP mstr clk out	UART0_TX, UART xmit data
41	65	L10	P3.5	I/O	GPIO_3.5, GP Input, HiZ	EXINT5, External Intr	SSP1_MISO, SSP mstr data in	GPIO_3.5, GP Output	SSP1_MISO, SSP slv data out	UART2_TX, UART xmit data
42	66	M12	P3.6	I/O	GPIO_3.6, GP Input, HiZ	EXINT6, External Intr	SSP1_MOSI, SSP slv dat in	GPIO_3.6, GP Output	SSP1_MOSI, SSP mstr dat out	CAN_TX, CAN Tx data
43	68	K11	P3.7	I/O	GPIO_3.7, GP Input, HiZ	EXINT7, External Intr	SSP1_NSS, SSP slv select in	GPIO_3.7, GP Output	SSP1_NSS, SSP mstr sel out	TIM1_OCMP1, Out comp/PWM
4	3	C2	P4.0	I/O	GPIO_4.0, GP Input, HiZ	ADC0, ADC input chnl	TIM0_ICAP1, Input Capture	GPIO_4.0, GP Output	TIM0_OCMP1, Out comp/PWM	ETM_PCK0, ETM Packet
3	2	B2	P4.1	I/O	GPIO_4.1, GP Input, HiZ	ADC1, ADC input chnl	TIM0_ICAP2, Input Capture	GPIO_4.1, GP Output	TIM0_OCMP2, Out comp	ETM_PCK1, ETM Packet
2	1	A1	P4.2	I/O	GPIO_4.2, GP Input, HiZ	ADC2, ADC input chnl	TIM1_ICAP1, Input Capture	GPIO_4.2, GP Output	TIM1_OCMP1, Out comp/PWM	ETM_PCK2, ETM Packet
1	128	B3	P4.3	I/O	GPIO_4.3, GP Input, HiZ	ADC3, ADC input chnl	TIM1_ICAP2, Input Capture	GPIO_4.3, GP Output	TIM1_OCMP2, Out comp	ETM_PCK3, ETM Packet
80	127	C4	P4.4	I/O	GPIO_4.4, GP Input, HiZ	ADC4, ADC input chnl	TIM2_ICAP1, Input Capture	GPIO_4.4, GP Output	TIM2_OCMP1, Out comp/PWM	ETM_PSTAT0, ETM pipe status
79	126	B4	P4.5	I/O	GPIO_4.5, GP Input, HiZ	ADC5, ADC input chnl	TIM2_ICAP2, Input Capture	GPIO_4.5, GP Output	TIM2_OCMP2, Out comp	ETM_PSTAT1, ETM pipe status
78	125	A4	P4.6	I/O	GPIO_4.6, GP Input, HiZ	ADC6, ADC input chnl	TIM3_ICAP1, Input Capture	GPIO_4.6, GP Output	TIM3_OCMP1, Out comp/PWM	ETM_PSTAT2, ETM pipe status
77	124	D5	P4.7	I/O	GPIO_4.7, GP Input, HiZ	ADC7, ADC input chnl /ADC Ext. trigger	TIM3_ICAP2, Input Capture	GPIO_4.7, GP Output	TIM3_OCMP2, Out comp	ETM_TRSYNC, ETM trace sync
9	12	E4	P5.0	I/O	GPIO_5.0, GP Input, HiZ	EXINT8, External Intr	CAN_RX, CAN rcv data	GPIO_5.0, GP Output	ETM_TRCLK, ETM trace clock	UART0_TX, UART xmit data
12	18	F6	P5.1	I/O	GPIO_5.1, GP Input, HiZ	EXINT9, External Intr	UART0_RxD, UART rcv data	GPIO_5.1, GP Output	CAN_TX, CAN Tx data	UART2_TX, UART xmit data
17	25	K1	PHYCLK_P5.2	I/O	GPIO_5.2, GP Input, HiZ	EXINT10, External Intr	UART2_RxD, UART rcv data	GPIO_5.2, GP Output	MII_PHYCLK, 25Mhz to PHY	TIM3_OCMP1, Out comp/PWM
18	27	H2	P5.3	I/O	GPIO_5.3, GP Input, HiZ	EXINT11, External Intr	ETM_EXTRIG, ETM ext. trigger	GPIO_5.3, GP Output	MII_TX_EN, MAC xmit enbl	TIM2_OCMP1, Out comp/PWM

Table 8. Device pin description (continued)

Package			Pin name	Signal type	Default pin function	Default input function	Alternate functions			
LQFP80	LQFP128	LFPGA144					Alternate input 1	Alternate output 1	Alternate output 2	Alternate output 3
44	70	J12	P5.4	I/O	GPIO_5.4, GP Input, HiZ	EXINT12, External Intr	SSP0_SCLK, SSP slv clk in	GPIO_5.4, GP Output	SSP0_SCLK, SSP mstr clk out	EMI_CS0n, EMI Chip Select
47	77	H11	P5.5	I/O	GPIO_5.5, GP Input, HiZ	EXINT13, External Intr	SSP0_MOSI, SSP slv dat in	GPIO_5.5, GP Output	SSP0_MOSI, SSP mstr dat out	EMI_CS1n, EMI Chip Select
48	79	H9	P5.6	I/O	GPIO_5.6, GP Input, HiZ	EXINT14, External Intr	SSP0_MISO, SSP mstr dat in	GPIO_5.6, GP Output	SSP0_MISO, SSP slv data out	EMI_CS2n, EMI Chip Select
49	80	G12	P5.7	I/O	GPIO_5.7, GP Input, HiZ	EXINT15, External Intr	SSP0_NSS, SSP slv select in	GPIO_5.7, GP Output	SSP0_NSS, SSP mstr sel out	EMI_CS3n, EMI Chip Select
19	29	H4	P6.0	I/O	GPIO_6.0, GP Input, HiZ	EXINT16, External Intr	TIM0_ICAP1, Input Capture	GPIO_6.0, GP Output	TIM0_OCMP1, Out comp/PWM	MC_UH, IMC phase U hi
20	31	J3	P6.1	I/O	GPIO_6.1, GP Input, HiZ	EXINT17, External Intr	TIM0_ICAP2, Input Capture	GPIO_6.1, GP Output	TIM0_OCMP2, Out comp	MC_UL, IMC phase U lo
13	19	G2	P6.2	I/O	GPIO_6.2, GP Input, HiZ	EXINT18, External Intr	TIM1_ICAP1, Input Capture	GPIO_6.2, GP Output	TIM1_OCMP1, Out comp/PWM	MC_VH, IMC phase V hi
14	20	G3	P6.3	I/O	GPIO_6.3, GP Input, HiZ	EXINT19, External Intr	TIM1_ICAP2, Input Capture	GPIO_6.3, GP Output	TIM1_OCMP2, Out comp	MC_VL, IMC phase V lo
52	83	G8	P6.4	I/O	GPIO_6.4, GP Input, HiZ	EXINT20, External Intr	TIM2_ICAP1, Input Capture	GPIO_6.4, GP Output	TIM2_OCMP1, Out comp/PWM	MC_WH, IMC phase W hi
53	84	G7	P6.5	I/O	GPIO_6.5, GP Input, HiZ	EXINT21, External Intr	TIM2_ICAP2, Input Capture	GPIO_6.5, GP Output	TIM2_OCMP2, Out comp	MC_WL, IMC phase W lo
57	92	E9	P6.6	I/O	GPIO_6.6, GP Input, HiZ	EXINT22_TRIG, Ext Intr & Tach	UART0_RxD, UART rcv data	GPIO_6.6, GP Output	TIM3_OCMP1, Out comp/PWM	ETM_TRCLK, ETM trace clock
58	93	D12	P6.7	I/O	GPIO_6.7, GP Input, HiZ	EXINT23_STOP, Ext Intr & Estop	ETM_EXTRIG, ETM ext. trigger	GPIO_6.7, GP Output	TIM3_OCMP2, Out comp	UART0_TX, UART xmit data
-	5	D1	P7.0	I/O	GPIO_7.0, GP Input, HiZ	EXINT24, External Intr	TIM0_ICAP1, Input Capture	GPIO_7.0, GP Output	8b) EMI_A0, 16b) EMI_A16	ETM_PCK0, ETM Packet
-	6	D2	P7.1	I/O	GPIO_7.1, GP Input, HiZ	EXINT25, External Intr	TIM0_ICAP2, Input Capture	GPIO_7.1, GP Output	8b) EMI_A1, 16b) EMI_A17	ETM_PCK1, ETM Packet
-	7	B1	P7.2	I/O	GPIO_7.2, GP Input, HiZ	EXINT26, External Intr	TIM2_ICAP1, Input Capture	GPIO_7.2, GP Output	8b) EMI_A2, 16b) EMI_A18	ETM_PCK2, ETM Packet
-	13	F1	P7.3	I/O	GPIO_7.3, GP Input, HiZ	EXINT27, External Intr	TIM2_ICAP2, Input Capture	GPIO_7.3, GP Output	8b) EMI_A3, 16b) EMI_A19	ETM_PCK3, ETM Packet
-	14	G1	P7.4	I/O	GPIO_7.4, GP Input, HiZ	EXINT28, External Intr	UART0_RxD, UART rcv data	GPIO_7.4, GP Output	8b) EMI_A4, 16b) EMI_A20	EMI_CS3n, EMI Chip Select
-	15	E5	P7.5	I/O	GPIO_7.5, GP Input, HiZ	EXINT29, External Intr	ETM_EXTRIG, ETM ext. trigger	GPIO_7.5, GP Output	8b) EMI_A5, 16b) EMI_A21	EMI_CS2n, EMI Chip Select
-	118	E6	P7.6	I/O	GPIO_7.6, GP Input, HiZ	EXINT30, External Intr	TIM3_ICAP1, Input Capture	GPIO_7.6, GP Output	8b) EMI_A6, 16b) EMI_A22	EMI_CS1n, EMI Chip Select
-	119	A5	P7.7	I/O	GPIO_7.7, GP Input, HiZ	EXINT31, External Intr	TIM3_ICAP2, Input Capture	GPIO_7.7, GP Output	EMI_CS0n, EMI chip select	16b) EMI_A23, 8b) EMI_A7

Table 8. Device pin description (continued)

Package			Pin name	Signal type	Default pin function	Default input function	Alternate functions			
LQFP80	LQFP128	LFPGA144					Alternate input 1	Alternate output 1	Alternate output 2	Alternate output 3
-	26	L1	P8.0	I/O	GPIO_8.0, GP Input, HiZ	-	-	GPIO_8.0, GP Output	8b) EMI_D0, 16b) EMI_AD0	-
-	28	H3	P8.1	I/O	GPIO_8.1, GP Input, HiZ	-	-	GPIO_8.1, GP Output	8b) EMI_D1, 16b) EMI_AD1	-
-	30	J2	P8.2	I/O	GPIO_8.2, GP Input, HiZ	-	-	GPIO_8.2, GP Output	8b) EMI_D2, 16b) EMI_AD2	-
-	32	K2	P8.3	I/O	GPIO_8.3, GP Input, HiZ	-	-	GPIO_8.3, GP Output	8b) EMI_D3, 16b) EMI_AD3	-
-	34	L3	P8.4	I/O	GPIO_8.4, GP Input, HiZ	-	-	GPIO_8.4, GP Output	8b) EMI_D4, 16b) EMI_AD4	-
-	36	J4	P8.5	I/O	GPIO_8.5, GP Input, HiZ	-	-	GPIO_8.5, GP Output	8b) EMI_D5, 16b) EMI_AD5	-
-	38	M2	P8.6	I/O	GPIO_8.6, GP Input, HiZ	-	-	GPIO_8.6, GP Output	8b) EMI_D6, 16b) EMI_AD6	-
-	44	K5	P8.7	I/O	GPIO_8.7, GP Input, HiZ	-	-	GPIO_8.7, GP Output	8b) EMI_D7, 16b) EMI_AD7	-
-	46	M6	P9.0	I/O	GPIO_9.0, GP Input, HiZ	-	-	GPIO_9.0, GP Output	8b) EMI_A8, 16b) EMI_AD8	-
-	47	M7	P9.1	I/O	GPIO_9.1, GP Input, HiZ	-	-	GPIO_9.1, GP Output	8b) EMI_A9, 16b) EMI_AD9	-
-	50	K6	P9.2	I/O	GPIO_9.2, GP Input, HiZ	-	-	GPIO_9.2, GP Output	8b) EMI_A10, 16b) EMI_AD10	-
-	51	J6	P9.3	I/O	GPIO_9.3, GP Input, HiZ	-	-	GPIO_9.3, GP Output	8b) EMI_A11, 16b) EMI_AD11	-
-	52	H6	P9.4	I/O	GPIO_9.4, GP Input, HiZ	-	-	GPIO_9.4, GP Output	8b) EMI_A12, 16b) EMI_AD12	-
-	58	L8	P9.5	I/O	GPIO_9.5, GP Input, HiZ	-	-	GPIO_9.5, GP Output	8b) EMI_A13, 16b) EMI_AD13	-
-	62	M9	P9.6	I/O	GPIO_9.6, GP Input, HiZ	-	-	GPIO_9.6, GP Output	8b) EMI_A14, 16b) EMI_AD14	-
-	64	K9	P9.7	I/O	GPIO_9.7, GP Input, HiZ	-	-	GPIO_9.7, GP Output	8b) EMI_A15, 16b) EMI_AD15	-
-	21	G4	EMI_BWR_WRLn	O	EMI byte write strobe (8 bit mode) or low byte write strobe (16 bit mode) Can also be configured as EMI_LBn in BGA package			N/A		

Table 8. Device pin description (continued)

Package			Pin name	Signal type	Default pin function	Default input function	Alternate functions			
LQFP80	LQFP128	LFBGA144					Alternate input 1	Alternate output 1	Alternate output 2	Alternate output 3
-	22	H1	EMI_WR Hn	O	EMI high byte write strobe (16-bit mode) Can also be configured as EMI_UBn in BGA package		N/A			
-	74	J10	EMI_ALE	O	EMI address latch enable (mux mode)		N/A			
-	75	J9	EMI_RDn	O	EMI read strobe		N/A			
-	-	H8	EMI_BAA n	O	EMI Burst address advance		N/A			
-	-	K8	EMI_WAI Tn	I	EMI Wait input for burst mode device		N/A			
-	-	M8	EMI_BCL K	O	EMI bus clock		N/A			
-	-	A12	EMI_WE n	O	EMI write enable		N/A			
-	91	E10	TAMPER _IN	I	Tamper detection input		N/A			
-	94	D11	MII_MDI O	I/O	MAC/PHY management data line		N/A			
59	95	D10	USBDN	I/O	USB data (-) bus connect		N/A			
60	96	C11	USBDP	I/O	USB data (+) bus connect		N/A			
56	89	C12	RESET _INn	I	External reset input		N/A			
62	100	A9	RESET _OUTn	O	Global or System reset output		N/A			
65	104	A10	X1_CPU	I	CPU oscillator or crystal input		N/A			
64	103	A11	X2_CPU	O	CPU crystal connection		N/A			
27	42	M5	X1_RTC	I	RTC oscillator or crystal input (32.768 kHz)		N/A			
26	41	M4	X2_RTC	O	RTC crystal connection		N/A			
61	97	B11	JRTCK	O	JTAG return clock or RTC clock		N/A			
67	107	D8	JTRSTn	I	JTAG TAP controller reset		N/A			

Table 8. Device pin description (continued)

Package			Pin name	Signal type	Default pin function	Default input function	Alternate functions			
LQFP80	LQFP128	LFPGA144					Alternate input 1	Alternate output 1	Alternate output 2	Alternate output 3
68	108	E8	JTCK	I	JTAG clock	N/A				
69	111	A6	JTMS	I	JTAG mode select	N/A				
72	115	C6	JTDI	I	JTAG data in	N/A				
73	117	B6	JTDO	O	JTAG data out	N/A				
-	122	A3	AVDD	V	ADC analog voltage source, 2.7V - 3.6V	N/A				
-	4	C3	AVSS	G	ADC analog ground	N/A				
5	-	-	AVSS_VSSQ	G	Common ground point for digital I/O & analog ADC	N/A				
-	123	A2	AVREF	V	ADC reference voltage input	N/A				
76	-	-	AVREF_AVDD	V	Combined ADC ref voltage and ADC analog voltage source, 2.7V - 3.6V	N/A				
24	39	M3	VBATT	V	Standby voltage input for RTC and SRAM backup	N/A				
6	9	E1	VDDQ	V	V Source for I/O and USB. 2.7V to 3.6V	N/A				
15	23	J1	VDDQ	V						
36	57	-	VDDQ	V						
46	73	K12	VDDQ	V						
54	86	B5	VDDQ	V						
28	43	L5	VDDQ	V						
63	102	H7	VDDQ	V						
74	120	D9	VDDQ	V						
-	-	F9	VDDQ	V						

Table 8. Device pin description (continued)

Package			Pin name	Signal type	Default pin function	Default input function	Alternate functions			
LQFP80	LQFP128	LFPGA144					Alternate input 1	Alternate output 1	Alternate output 2	Alternate output 3
-	8	L2	VSSQ	G	Digital Ground for I/O and USB					
16	24	K4	VSSQ	G						
35	56	C5	VSSQ	G						
-	-	D4	VSSQ	G						
45	72	G5	VSSQ	G						
55	87	J7	VSSQ	G						
25	40	A8	VSSQ	G						
66	105	F8	VSSQ	G						
75	121	L12	VSSQ	G						
11	17	F4	VDD	V	V Source for CPU. 1.65V - 2.0V					
31	49	D7	VDD	V						
50	81	L6	VDD	V						
70	112	G11	VDD	V						
10	16	F3	VSS	G	Digital Ground for CPU					
30	48	H5	VSS	G						
51	82	G10	VSS	G						
71	113	E7	VSS	G						
-	-	C9	PLLVDQ	V	V Source for PLL 2.7 to 3.6 V					
-	-	B8	PLLVSSQ	G						

6 Memory mapping

The ARM966E-S CPU addresses a single linear address space of 4 giga-bytes (2^{32}) from address 0x0000.0000 to 0xFFFF.FFFF as shown in [Figure 9](#). Upon reset the CPU boots from address 0x0000.0000, which is chip-select zero at address zero in the Flash Memory Interface (FMI).

The Instruction TCM and Data TCM enable high-speed CPU operation without incurring any performance or power penalties associated with accessing the system buses (AHB and APB). I-TCM and D-TCM address ranges are shown at the bottom of the memory map in [Figure 9](#).

6.1 Buffered and non-buffered writes

The CPU makes use of write buffers on the AHB and the D-TCM to decouple the CPU from any wait states associated with a write operation. The user may choose to use write with buffers on the AHB by setting bit 3 in control register CP15 and selecting the appropriate AHB address range when writing. By default at reset, buffered writes are disabled (bit 3 of CP15 is clear) and all AHB writes are non-buffered until enabled. [Figure 9](#) shows that most addressable items on the AHB are aliased at two address ranges, one for buffered writes and another for non-buffered writes. A buffered write will allow the CPU to continue program execution while the write-back is performed through a FIFO to the final destination on the AHB. If the FIFO is full, the CPU is stalled until FIFO space is available. A non-buffered write will impose an immediate delay to the CPU, but results in a direct write to the final AHB destination, ensuring data coherency. Read operations from AHB locations are always direct and never buffered.

6.2 System (AHB) and peripheral (APB) buses

The CPU will access SRAM, higher-speed peripherals (USB, Ethernet, Programmable DMA), and the external bus (EMI) on the AHB at their respective base addresses indicated in [Figure 9](#). Lower-speed peripherals reside on the APB and are accessed using two separate AHB-to-APB bridge units (APB0 and APB1). These bridge units are essentially address windows connecting the AHB to the APB. To access an individual APB peripheral, the CPU will place an address on the AHB bus equal to the base address of the appropriate bridge unit APB0 or APB1, plus the offset of the particular peripheral, plus the offset of the individual data location within the peripheral. [Figure 9](#) shows the base addresses of bridge units APB0 and APB1, and also the base address of each APB peripheral. Please consult the STR91xFA Reference manual for the address of data locations within each individual peripheral.

6.3 SRAM

The SRAM is aliased at three separate address ranges as shown in [Figure 9](#). When the CPU accesses SRAM starting at 0x0400.0000, the SRAM appears on the D-TCM. When CPU access starts at 0x4000.0000, SRAM appears in the buffered AHB range. Beginning at CPU address 0x5000.0000, SRAM is in non-buffered AHB range. The SRAM size must be specified by CPU initialization firmware writing to a control register after any reset condition.

Default SRAM size is 32K bytes, with option to set to 64K bytes on STR91xFAx3x devices, and to 96K bytes on STR91xFAx4x devices.

When other AHB bus masters (such as a DMA controller) write to SRAM, their access is never buffered. Only the CPU can make use of buffered AHB writes.

6.4 Two independent Flash memories

The STR91xFA has two independent Flash memories, the larger primary Flash and the small secondary Flash. It is possible for the CPU to erase/write to one of these Flash memories while simultaneously reading from the other.

One or the other of these two Flash memories may reside at the “boot” address position of 0x0000.0000 at power-up or at reset as shown in [Figure 9](#). The default configuration is that the first sector of primary Flash memory is enabled and residing at the boot position, and the secondary Flash memory is disabled. This default condition may be optionally changed as described below.

6.4.1 Default configuration

When the primary Flash resides at boot position, typical CPU initialization firmware would set the start address and size of the main Flash memory, and go on to enable the secondary Flash, define its start address and size. Most commonly, firmware would place the secondary Flash start address at the location just after the end of the primary Flash memory. In this case, the primary Flash is used for code storage, and the smaller secondary Flash can be used for data storage (EEPROM emulation).

6.4.2 Optional configuration

Using the STR91xFA device configuration software tool, or IDE from 3rd party, one can specify that the smaller secondary Flash memory is at the boot location at reset and the primary Flash is disabled. The selection of which Flash memory is at the boot location is programmed in a non-volatile Flash-based configuration bit during JTAG ISP. The boot selection choice will remain as the default until the bit is erased and re-written by the JTAG interface. The CPU cannot change this choice for boot Flash, only the JTAG interface has access.

In this case where the secondary Flash defaults to the boot location upon reset, CPU firmware would typically initialize the Flash memories the following way. The secondary Flash start address and size is specified, then the primary Flash is enabled and its start address and size is specified. The primary Flash start address would typically be located just after the final address location of the secondary Flash. This configuration is particularly well-suited for In-Application-Programming (IAP). The CPU would boot from the secondary Flash memory, initialize the system, then check the contents of the primary Flash memory (by checksum or other means). If the contents of primary Flash is OK, then CPU execution continues from either Flash memory. If the main Flash contents are incorrect, the CPU, while executing code from the secondary Flash, can download new data from any STR91xFA communication channel and program into primary Flash memory. Application code then starts after the new contents of primary Flash are verified.

6.5 STR91xFA memory map

The memory map is shown in [Figure 9: STR91xFA memory map on page 56](#):

- Either of the two Flash memories may be placed at CPU boot address 0x0000.0000. By default, the primary Flash memory is in boot position starting at CPU address 0x0000.0000 and the secondary Flash memory may be placed at a higher address following the end of the primary Flash memory. This default option may be changed using the STR91xx device configuration software, placing the secondary Flash memory at CPU boot location 0x0000.0000, and then the primary Flash memory may be placed at a higher address.
- The local SRAM (64KB or 96KB) is aliased in three address windows. A) At 0x0400.0000 the SRAM is accessible through the CPU's D-TCM, at 0x4000.0000 the SRAM is accessible through the CPU's AHB in buffered accesses, and at 0x5000.0000 the SRAM is accessible through the CPU's AHB in non-buffered accesses. An AHB bus master other than the CPU can access SRAM in all three aliased windows, but these accesses are always non-buffered. The CPU is the only AHB master that can performed buffered writes.
- APB peripherals reside in two AHB-to-APB peripheral bridge address windows, APB0 and APB1. These peripherals are accessible with buffered AHB access if the CPU addresses them in the address range of 0x4800.0000 to 0x4FFF.FFFF, and non-buffered access in the address range of 0x5800.0000 to 0x5FFF.FFFF.
- Individual peripherals on the APB are accessed at the listed address offset plus the base address of the appropriate AHB-to-APB bridge.

Figure 9. STR91xFA memory map

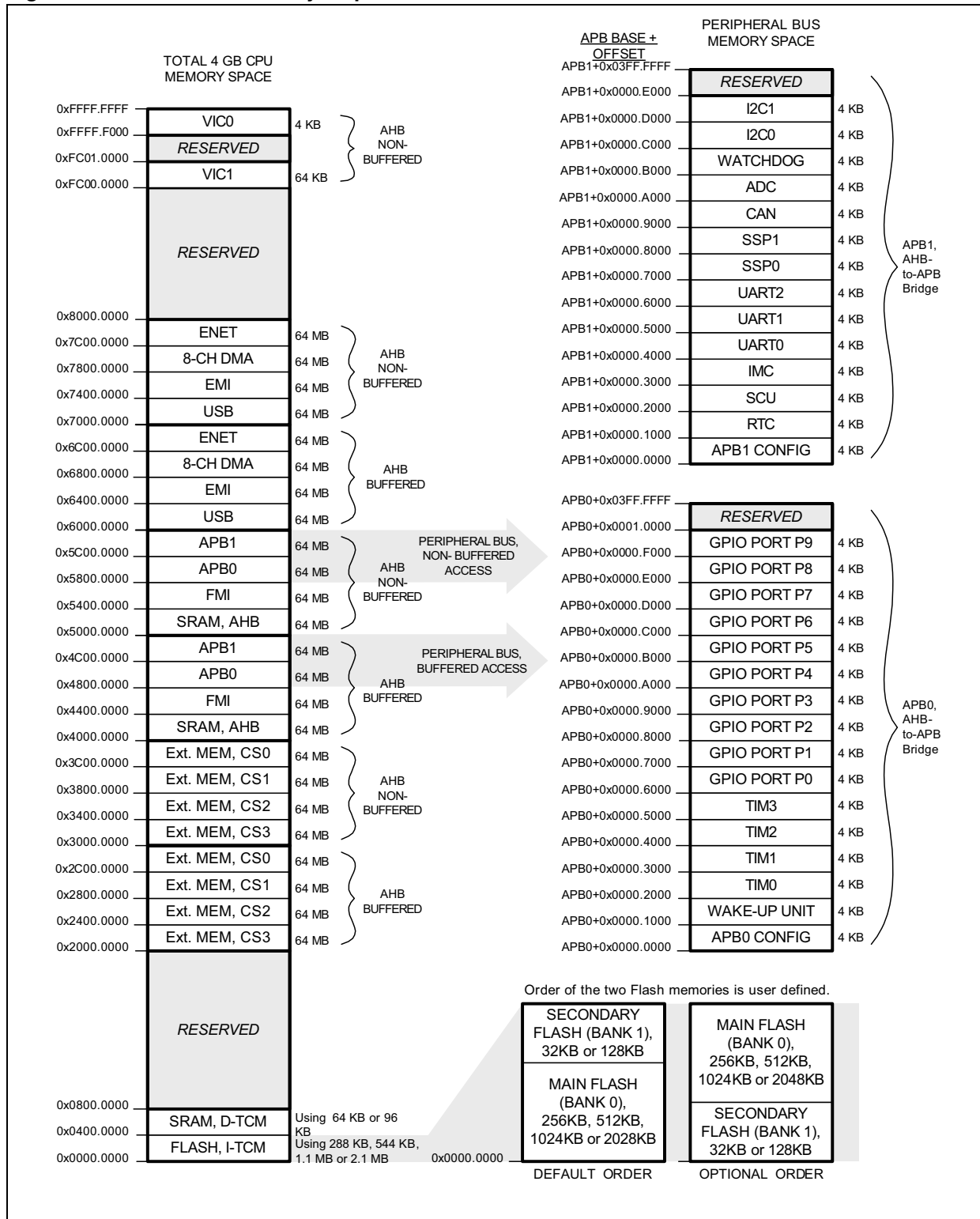

7 Electrical characteristics

7.1 Parameter conditions

Unless otherwise specified, all voltages are referred to V_{SS} .

7.1.1 Minimum and maximum values

Unless otherwise specified the minimum and maximum values are guaranteed in the worst conditions of ambient temperature, supply voltage and frequencies by tests in production on 100% of the devices with an ambient temperature at T_A max (given by the selected temperature range).

Data based on product characterisation, design simulation and/or technology characteristics are indicated in the table footnotes and are not tested in production. Based on characterization, the minimum and maximum values refer to sample tests and represent the mean value plus or minus three times the standard deviation ($\text{mean} \pm 3\sigma$).

7.1.2 Typical values

Unless otherwise specified, typical data are based on $T_A=25^\circ\text{C}$, $V_{DDQ}=3.3\text{V}$ and $V_{DD}=1.8\text{V}$. They are given only as design guidelines and are not tested.

Typical ADC accuracy values are determined by characterization of a batch of samples from a standard diffusion lot over the full temperature range, where 95% of the devices have an error less than or equal to the value indicated ($\text{mean} \pm 2\sigma$).

7.1.3 Typical curves

Unless otherwise specified, all typical curves are given only as design guidelines and are not tested.

7.1.4 Loading capacitor

The loading conditions used for pin parameter measurement are shown in [Figure 10](#).

Figure 10. Pin loading conditions

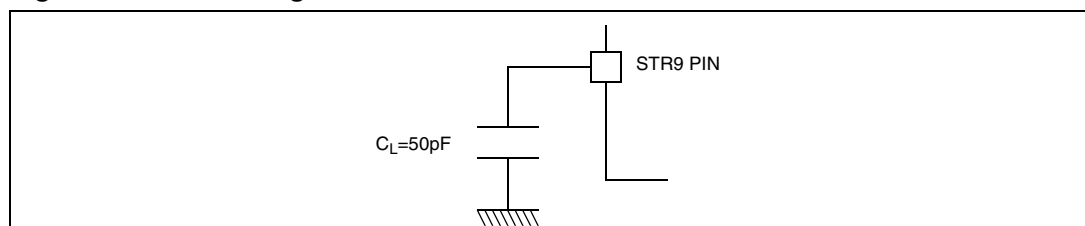

7.1.5 Pin input voltage

The input voltage measurement on a pin of the device is described in [Figure 11](#).

Figure 11. Pin input voltage

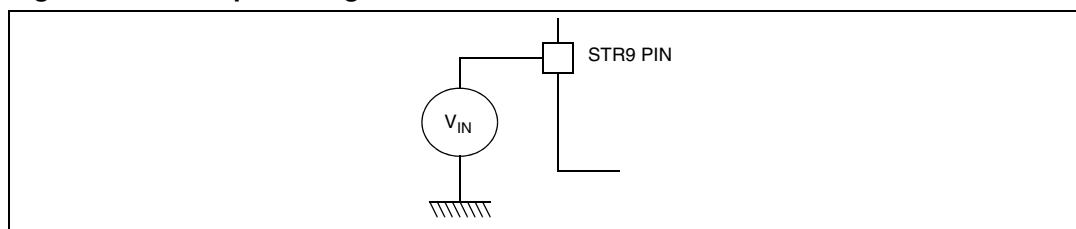

7.2 Absolute maximum ratings

This product contains devices to protect the inputs against damage due to high static voltages. However, it is advisable to take normal precautions to avoid application of any voltage higher than the specified maximum rated voltages. It is also recommended to ground any unused input pin to reduce power consumption and minimize noise.

Table 9. Absolute maximum ratings

Symbol	Parameter	Value		Unit
		Min	Max	
V_{DD}	Voltage on VDD pin with respect to ground V_{SS}	-0.3	2.4	V
V_{DDQ}	Voltage on VDDQ pin with respect to ground V_{SS}	-0.3	4.0	V
V_{BATT}	Voltage on VBATT pin with respect to ground V_{SS}	-0.3	4.0	V
AV_{DD}	Voltage on AVDD pin with respect to ground V_{SS} (128-pin and 144-ball packages)	-0.3	4.0	V
AV_{REF}	Voltage on AVREF pin with respect to ground V_{SS} (128-pin and 144-ball packages)	-0.3	4.0	V
AV_{REF_AVDD}	Voltage on AVREF_AVDD pin with respect to Ground V_{SS} (80-pin package)	-0.3	4.0	V
V_{IN}	Voltage on 5V tolerant pins with respect to ground V_{SS}	-0.3	5.5	V
	Voltage on any other pin with respect to ground V_{SS}	-0.3	4.0	V
T_{ST}	Storage Temperature	-55	+150	°C
T_J	Junction Temperature		+125	°C
ESD	ESD Susceptibility (Human Body Model)	2000		V

Note: Stresses exceeding above listed recommended "Absolute Maximum Ratings" may cause permanent damage to the device. This is a stress rating only and functional operation of the device at these or any other conditions above those indicated in the operational sections of this specification is not implied. Exposure to absolute maximum rating conditions for extended periods may affect device reliability. During overload conditions ($V_{IN} > V_{DDQ}$ or $V_{IN} < V_{SSQ}$) the voltage on pins with respect to ground (V_{SSQ}) must not exceed the recommended values.

Table 10. Current characteristics

Symbol	Ratings	Maximum value	Unit
$I_{VDD_IO}^{(1)}$	Total current into V_{DD_IO} power lines (source) ⁽²⁾	200	mA
$I_{VSS_IO}^{(1)}$	Total current out of V_{SS} ground lines (sink) ⁽²⁾	200	
I_{IO}	Output current sunk by any I/O and control pin	25	
	Output current source by any I/Os and control pin	- 25	
$I_{INJ(PIN)}^{(3)}$	Injected current on any pin during overload condition ⁽⁴⁾	± 5	mA
$\Sigma I_{INJ(PIN)}^{(3)}$	Absolute sum of all input currents during overload condition ⁽⁴⁾	± 25	

1. The user can use GPIOs to source or sink current. In this case, the user must ensure that these absolute max. values are not exceeded (taking into account the RUN power consumption).
2. All 3.3 V or 5.0 V power (V_{DD_IO} , V_{DDA_ADC} , V_{DDA_PLL}) and ground (V_{SS_IO} , V_{SSA_ADC} , V_{DDA_ADC}) pins must always be connected to the external 3.3V or 5.0V supply.
3. $I_{INJ(PIN)}$ must never be exceeded. This is implicitly insured if V_{IN} maximum is respected. If V_{IN} maximum cannot be respected, the injection current must be limited externally to the $I_{INJ(PIN)}$ value. A positive injection is induced by $V_{IN} > V_{DD}$ while a negative injection is induced by $V_{IN} < V_{SS}$.
4. When several inputs are submitted to a current injection, the maximum $\Sigma I_{INJ(PIN)}$ is the absolute sum of the positive and negative injected currents (instantaneous values). These results are based on characterization with $\Sigma I_{INJ(PIN)}$ maximum current injection on four I/O port pins of the device.

7.3 Operating conditions

Table 11. Operating conditions

Symbol	Parameter	Conditions	Value		Unit
			Min	Max	
V _{DD}	Digital CPU supply voltage	Flash size ≤ 12 KB	1.65	2.0	V
		Flash size = 1 MB / 2 MB, f _{CPUCCLK} ≤ 85 MHz ⁽¹⁾	1.65	2.0	V
		Flash size = 1 MB / 2 MB, f _{CPUCCLK} ≤ 96 MHz ⁽²⁾	1.77	2.0	V
V _{DDQ}	Digital I/O supply voltage		2.7	3.6	V
V _{BATT} ⁽³⁾	SRAM backup and RTC supply voltage		2.5	3.6	V
AV _{DD}	Analog ADC supply voltage (128-pin and 144-ball packages)		2.7	V _{DDQ}	V
AV _{REF}	Analog ADC reference voltage (128-pin and 144-ball packages)		2.65	AV _{DD} ⁽⁴⁾	V
AV _{REF_AVDD}	Combined analog ADC reference and ADC supply voltage (80-pin package)		2.7	V _{DDQ}	V
T _A	Ambient temperature under bias		-40	+85	C

1. f_{FMICLK} ≤ 48 MHz during Flash write and 85 MHz during all other operations.
2. f_{FMICLK} ≤ 48 MHz during Flash write and 96 MHz during all other operations.
3. The V_{BATT} pin should be connected to V_{DDQ} if no battery is installed
4. AV_{REF} must never exceed V_{DDQ}

7.3.1 Operating conditions at power-up / power-down

Subject to general operating conditions for T_A.

Table 12. Operating conditions at power-up / power-down

Symbol	Parameter	Min ⁽¹⁾	Max ⁽¹⁾	Unit
t _{VDD}	V _{DD} rise time rate	10		μs/V
			10	ms/V

1. Data guaranteed by characterization, not tested in production.

7.4 RESET_INn and power-on-reset characteristics

$V_{DDQ} = 2.7 - 3.6V$, $V_{DD} = 1.65 - 2V$, $T_A = -40 / 85\text{ }^\circ\text{C}$ unless otherwise specified.

Table 13. RESET_INn and power-on-reset characteristics

Symbol	Parameter	Test conditions	Value			Unit
			Min ⁽¹⁾	Typ	Max	
t_{RINMIN}	RESET_INn Valid Active Low		100			ns
t_{POR}	Power-On-Reset Condition duration	V_{DDQ}, V_{DD} ramp time is less than 10ms: 0V to V_{DD}	10			ms
t_{RSO}	RESET_OUT Duration (Watchdog reset)		one PCLK			ns

1. Data based on bench measurements, not tested in production.

7.5 LVD electrical characteristics

$V_{DDQ} = 2.7 - 3.6V$, $V_{DD} = 1.65 - 2V$, $T_A = -40 / 85\text{ }^\circ\text{C}$ unless otherwise specified.

Table 14. LVD electrical characteristics

Symbol	Parameter	Test conditions	Value			Unit
			Min	Typ	Max	
$V_{DD_LVD+} (1.8V)$	LVD threshold during V_{DD} rise		1.43	1.50	1.58	V
$V_{DD_LVD-} (1.8V)$	LVD threshold during V_{DD} fall		1.33	1.40	1.47	V
$V_{DD_BRN} (1.8V)$	V_{DD} brown out warning threshold			1.65		V
$V_{DDQ_LVD+} (3.0V)$	LVD threshold during V_{DDQ} rise	(1)(2)	2.32	2.45	2.57	V
$V_{DDQ_LVD-} (3.0V)$	LVD threshold during V_{DDQ} fall	(1)(2)	2.23	2.35	2.46	
$V_{DDQ_BRN} (3.0V)$	V_{DDQ} brown out warning threshold	(1)(2)		2.65		V
$V_{DDQ_LVD+} (3.3V)$	LVD threshold during V_{DDQ} rise	(2)(3)	2.61	2.75	2.89	V
$V_{DDQ_LVD-} (3.3V)$	LVD threshold during V_{DDQ} fall	(2)(3)	2.52	2.65	2.78	
$V_{DDQ_BRN} (3.3V)$	V_{DDQ} brown out warning threshold	(2)(3)		2.95		V

1. For V_{DDQ} I/O voltage operating at 2.7 - 3.3V.

2. Selection of V_{DDQ} operation range is made using configuration software from ST, or IDE from 3rd parties. The default condition is $V_{DDQ}=2.7V - 3.3V$.

3. For V_{DDQ} I/O voltage operating at 3.0 - 3.6V.

7.5.1 LVD reset delay timing

Case 1: When V_{DDQ} reaches the V_{DDQ_LVD+} threshold **after** the first ~ 10 ms delay (introduced by the VDD rising edge), a new ~ 10 ms delay starts before the release of RESET_OUTn. See [Figure 12](#).

Figure 12. LVD reset delay case 1

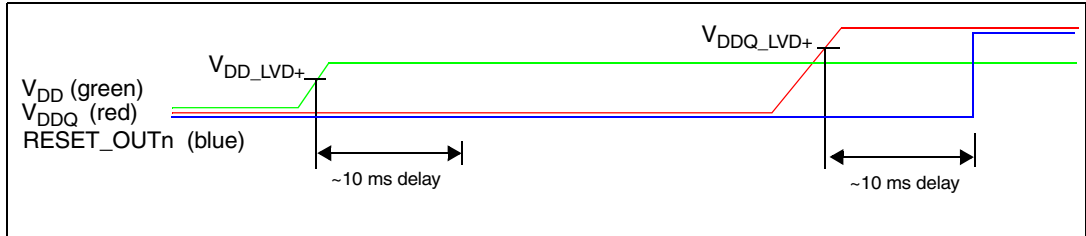

Case 2: When V_{DDQ} reaches the V_{DDQ_LVD+} threshold **before** the first ~ 10 ms delay (introduced by the VDD rising edge), RESET_OUTn will be released immediately at the end of the delay. No new delay is introduced in this case. See [Figure 13](#).

Figure 13. LVD reset delay case 2

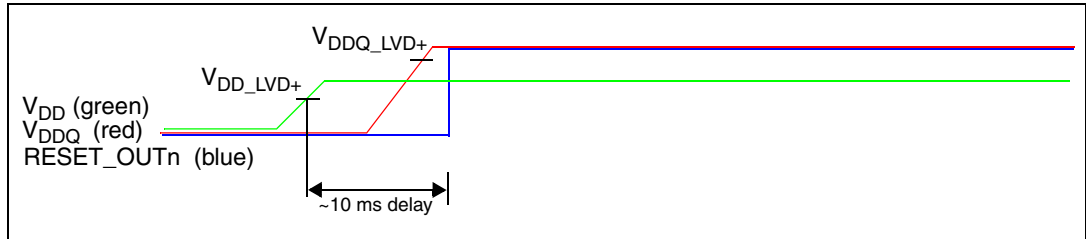

Case 3: When V_{DD} reaches the V_{DD_LVD+} threshold **after** the V_{DDQ} rising edge, RESET_OUTn will be released at the end of a ~ 10 ms delay. See [Figure 14](#).

Figure 14. LVD reset delay case 3

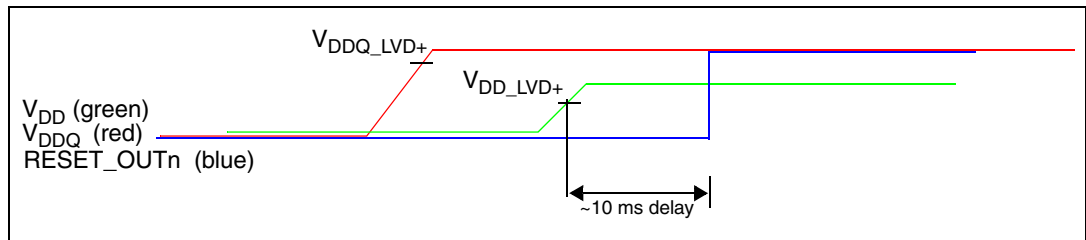

7.6 Supply current characteristics

$V_{DDQ} = 2.7 - 3.6V$, $V_{DD} = 1.65 - 2V$, $T_A = -40 / 85\text{ }^{\circ}C$ unless otherwise specified.

Table 15. Supply current characteristics

Symbol	Parameter	Test conditions	Value			Unit
			Min	Typ	Max	
I_{DDRUN}	Run mode current	All peripherals on ⁽¹⁾⁽²⁾		1.7	2.3	mA/MHz
		All peripherals off ⁽¹⁾⁽²⁾		1.3	1.6	
I_{IDLE}	Idle mode current	All peripherals on ⁽²⁾⁽³⁾		1.14	1.7	mA/MHz
		All peripherals off ⁽²⁾⁽⁴⁾		0.45	0.75	mA/MHz
$I_{SLEEP(IDD)}$	Sleep mode current, I_{DD}	ARM core and all peripheral clocks stopped (with exception of RTC), LVD off		50	820 ⁽⁵⁾	μA
		ARM core and all peripheral clocks stopped (with exception of RTC), LVD on		55	825 ⁽⁵⁾	
$I_{SLEEP(IDDQ)}$	Sleep mode current, I_{DDQ}	LVD On ⁽⁴⁾		7	80 ⁽⁵⁾	μA
		LVD Off ⁽⁴⁾		7	70 ⁽⁵⁾	μA
I_{RTC_STBY}	RTC Standby current	Measured on VBATT pin		0.9	1.2	μA
I_{SRAM_STBY}	SRAM Standby current	Measured on VBATT pin		5	240	μA

1. ARM core and peripherals active with all clocks on. Power can be conserved by turning off clocks to peripherals which are not required.
2. mA/MHz data valid down to 10 MHz. Below this frequency the ratio mA/MHz increases.
3. ARM core stopped and all peripheral clocks active.
4. ARM core stopped and all peripheral clocks stopped.
5. Results based on characterization, not tested in production.

Figure 15. Sleep mode current vs temperature with LVD on

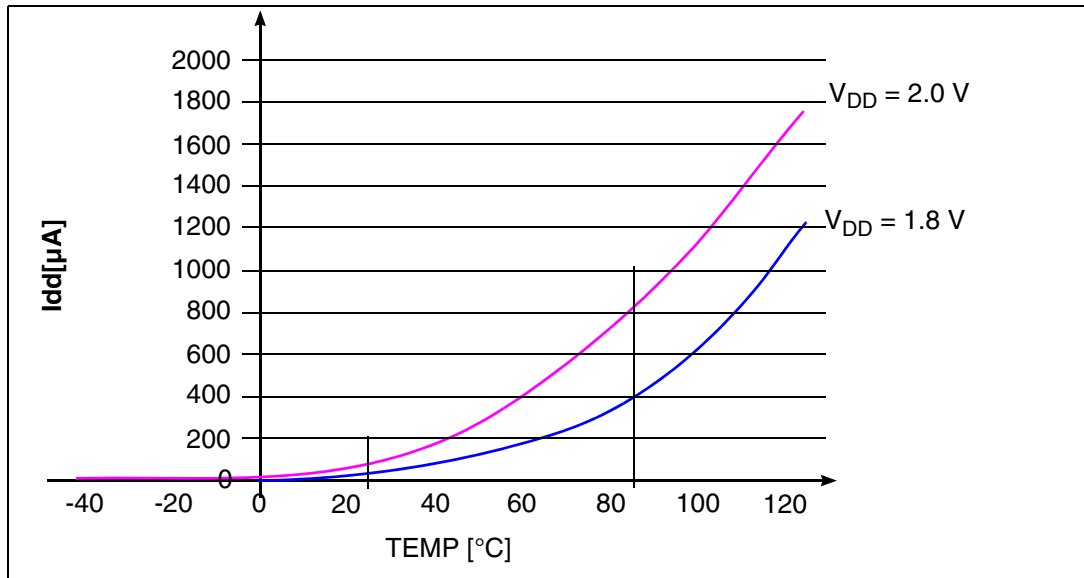

7.6.1 Typical power consumption for frequencies below 10 MHz

The following conditions apply to [Table 16](#):

- Program is executed from Flash. The program consists of an infinite loop.
- A standard crystal source is used.
- The PLL is off.
- All clock dividers are with their default values.

Table 16. Typical current consumption at 25 °C

Symbol	Parameter		Test conditions	Typical current on V _{DD} (1.8 V)	Unit
IDDRUN	Run mode current	All peripherals ON	f _{MSTR} =f _{OSC} =f _{PCLK} =f _{HCLK} =1 MHz	2.88	mA
			f _{MSTR} =f _{OSC} =f _{PCLK} =f _{HCLK} =2 MHz	5.8	
			f _{MSTR} =f _{OSC} =f _{PCLK} =f _{HCLK} =4 MHz	10.91	
			f _{MSTR} =f _{OSC} =f _{PCLK} =f _{HCLK} =6 MHz	15.97	
			f _{MSTR} =f _{OSC} =f _{PCLK} =f _{HCLK} =8 MHz	20.68	
			f _{MSTR} =f _{OSC} =f _{PCLK} =f _{HCLK} =10 MHz	25.13	
		All peripherals OFF	f _{MSTR} =f _{OSC} =f _{PCLK} =f _{HCLK} =1 MHz	1.8	
			f _{MSTR} =f _{OSC} =f _{PCLK} =f _{HCLK} =2 MHz	3.62	
			f _{MSTR} =f _{OSC} =f _{PCLK} =f _{HCLK} =4 MHz	6.71	
			f _{MSTR} =f _{OSC} =f _{PCLK} =f _{HCLK} =6 MHz	9.81	
			f _{MSTR} =f _{OSC} =f _{PCLK} =f _{HCLK} =8 MHz	12.63	
			f _{MSTR} =f _{OSC} =f _{PCLK} =f _{HCLK} =10 MHz	15.47	

7.7 Clock and timing characteristics

Table 17. Internal clock frequencies

Symbol	Parameter	Conditions	Value			Unit
			Min	Typ	Max	
f_{MSTR}	CCU Master clock		32.768		$f_{CPUCLKmax}$	kHz
f_{CPUCLK}	CPU Core frequency	Flash size ≤ 12 KB Executing from SRAM			96	MHz
		Flash size ≤ 12 KB Executing from Flash			96	MHz
		Flash size = 1 MB / 2 MB, executing from SRAM or Flash $V_{DD} \geq 1.77$ V			96	MHz
		Flash size = 1 MB / 2 MB, executing from SRAM or Flash $V_{DD} \geq 1.65$ V			85	MHz
f_{PCLK}	Peripheral clock for APB				48	MHz
f_{HCLK}	Peripheral clock for AHB				$f_{CPUCLKmax}$	MHz
f_{OSC}	Clock input		4		25	MHz
f_{FMICLK}	FMI Flash bus clock (internal clock)				$f_{CPUCLKmax}$	MHz
		Flash size = 1 MB / 2 MB, write operation to Flash memory or Flash registers			48	MHz
f_{BCLK}	External memory bus clock				$f_{CPUCLKmax}$	MHz
f_{RTC}	RTC clock		32.768			kHz
f_{EMAC}	EMAC PHY clock		25			MHz
f_{USB}	USB clock		48			MHz
$f_{TIMCLKEXT}$	Timer external clock		0		$f_{PCLKmax}/4 = 12$	MHz
f_{TIMCLK}	Timer clock when internal clock (PCLK) is selected		0		$f_{PCLKmax} = 48$	MHz

7.7.1 Main oscillator electrical characteristics

$V_{DDQ} = 2.7 - 3.6V$, $V_{DD} = 1.65 - 2V$, $T_A = -40 / 85\text{ }^\circ\text{C}$ unless otherwise specified.

Table 18. Main oscillator electrical characteristics

Symbol	Parameter	Test conditions	Value			Unit
			Min	Typ	Max	
$t_{STUP(OSC)}$	Oscillator Start-up Time	V_{DD} stable ⁽¹⁾		2	3	mS

1. Data characterized with quartz crystal, not tested in production.

7.7.2 X1_CPU external clock source

Subject to general operating conditions for V_{DD} and T_A .

Table 19. External clock characteristics

Symbol	Parameter	Test conditions ⁽¹⁾	Value			Unit	
			Min	Typ	Max		
f_{X1}	External clock source frequency	See Figure 16	4		25	MHz	
V_{X1H}	X1 input pin high level voltage		$0.7 \times V_{DD}$		V_{DD}	V	
V_{X1L}	X1 input pin low level voltage		V_{SS}		$0.3 \times V_{DD}$	V	
$t_{w(X1H)}$ $t_{w(X1L)}$	X1 high or low time ⁽²⁾		6			ns	
$t_r(X1)$ $t_f(X1)$	X1 rise or fall time ⁽²⁾				20	ns	
I_L	X1 input leakage current		$V_{SS} \nabla I_{IN} \nabla V_{DD}$			± 1	μA
$C_{IN(X1)}$	X1 input capacitance ⁽²⁾				5	pF	
$DuCy(X1)$	Duty cycle		45		55	%	

1. Data based on typical application software.

2. Data based on design simulation and/or technology characteristics, not tested in production.

Figure 16. Typical application with an external clock source

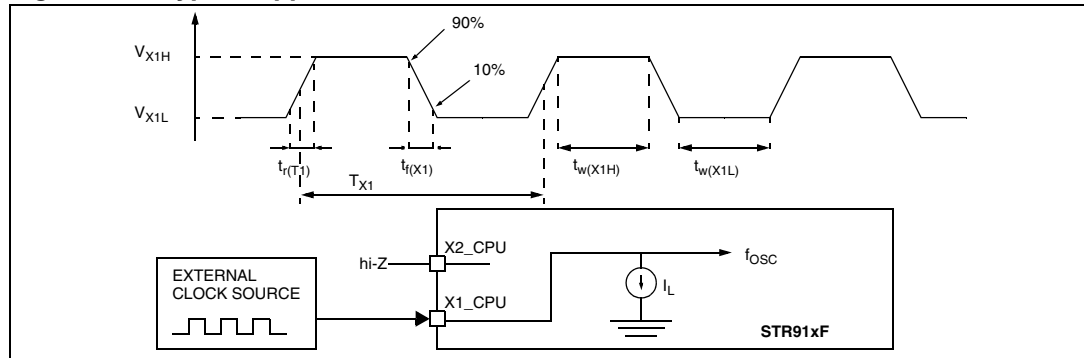

7.7.3 RTC clock generated from a crystal/ceramic resonator

The RTC (Real-Time Clock) can be supplied with a 32.768 kHz crystal/ceramic resonator oscillator. All the information given in this paragraph is based on characterization results obtained with typical external components specified in [Table 20](#) & [Table 21](#). In the application, the resonator and the load capacitors have to be placed as close as possible to the oscillator pins in order to minimize output distortion and startup stabilization time. Refer to the crystal resonator manufacturer for more details on the resonator characteristics (frequency, package, accuracy).

Note: For CL1 and CL2 it is recommended to use high-quality ceramic capacitors in the 5 pF to 16 pF range, selected to match the requirements of the crystal or resonator. CL1 and CL2, are usually the same size. The crystal manufacturer typically specifies a load capacitance which is the series combination of CL1 and CL2.

Load capacitance CL has the following formula:

$$CL = CL1 \times CL2 / (CL1 + CL2) + Cstray$$

where Cstray is the pin capacitance and board or trace PCB-related capacitance. Typically, it is between 2 pF and 7 pF.

Caution: Never use a resonator with a load capacitance of 12.5 pF.

Example: if you choose a resonator with a load capacitance of CL = 6 pF, and Cstray = 2 pF, then CL1 = CL2 = 8 pF.

Conditions: V_{DDQ} = 2.7 - 3.6V, V_{DD} = 1.65 - 2V, T_A = -40 / 85 °C unless otherwise specified.

Table 20. RTC oscillator electrical characteristics

Symbol	Parameter	Test conditions	Value			Unit
			Min	Typ	Max	
R _F	External feedback resistor			22		MΩ
V _{START(RTC)}	Oscillator start voltage		V _{DD_LVD+} ⁽¹⁾			V
g _M	Oscillator transconductance ⁽²⁾	Start-up	1.8			μA/Volts
t _{STUP(RTC)}	Oscillator Start-up Time ⁽²⁾	V _{DD} stable			1	S

1. Refer to [Table 14](#) for min. value of V_{DD_LVD+}

2. Data based on bench measurements, not tested in production.

Table 21. RTC crystal electrical characteristics

Symbol	Parameter	Value			Unit
		Min	Typ	Max	
f _O	Resonant frequency		32.768		kHz
R _S	Series resistance			40	kΩ
C _L	Load capacitance			8	pF

Figure 17. Typical application with a 32.768 kHz crystal

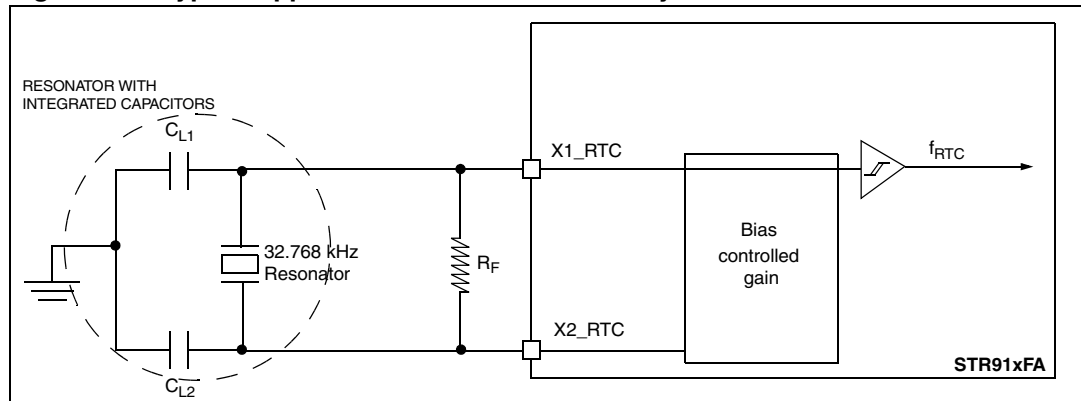

7.7.4 PLL electrical characteristics

$V_{DDQ} = 2.7 - 3.6V$, $V_{DD} = 1.65 - 2V$, $T_A = -40 / 85\text{ }^\circ\text{C}$ unless otherwise specified.

Table 22. PLL electrical characteristics

Symbol	Parameter	Value			Unit
		Min	Typ	Max	
f_{PLL}	PLL output clock	6.25		$f_{CPUCLKmax}$	MHz
f_{OSC}	Clock input	4		25	MHz
t_{LOCK}	PLL lock time		300	1500	μs
Δt_{JITTER}	PLL jitter (peak to peak) ⁽¹⁾		0.1	0.2	ns

1. Data based on bench measurements, not tested in production

7.8 Memory characteristics

7.8.1 SRAM characteristics

Table 23. SRAM and hardware registers

Symbol	Parameter	Conditions	Min	Typ	Max	Unit
V_{DR}	Supply voltage for data retention ⁽¹⁾	$T_A = 85\text{ }^\circ\text{C}$ (worst case)	1.1			V

1. Guaranteed by characterization, not tested in production.

7.8.2 Flash memory characteristics

$V_{DDQ} = 2.7 - 3.6V$, $V_{DD} = 1.65 - 2V$, $T_A = -40 / 85\text{ }^\circ\text{C}$ unless otherwise specified.

Note: Flash read access for sequential addresses is 0 wait states at 96 MHz.
Flash read access for non-sequential accesses requires 2 wait states when FMI clock is above 66 MHz. See STR91xF Flash Programming Manual for more information.

Table 24. Flash memory program/erase characteristics (Flash size $\leq 512\text{ KB}$)

Parameter	Test conditions	Value			Unit
		Typ ⁽¹⁾	Typ after 100K W/E cycles ⁽¹⁾	Max	
Bank erase	Primary bank (512 Kbytes)	8	9	11.5	s
	Primary bank (256 Kbytes)	4	4.5	6	s
	Secondary bank (32 Kbytes)	700	750	950	ms
Sector erase	Of primary bank (64 Kbytes)	1300	1400	1800	ms
	Of secondary bank (8 Kbytes)	300	320	450	ms
Bank program	Primary bank (512 Kbytes)	3700	4700	5100	ms
	Primary bank (256 Kbytes)	1900	2000	2550	ms
	Secondary bank (32 Kbytes)	250	260	320	ms
Sector program	Of primary bank (64 Kbytes)	500	520	640	ms
	Of secondary bank (8 Kbytes)	60	62	80	ms
Word program	Half word (16 bits)	8	9	11	μs

1. $V_{DD} = 1.8V$, $V_{DDQ} = 3.3V$, $T_A = 25^\circ\text{C}$.

Table 25. Flash memory program/erase characteristics (Flash size = 1 MB / 2 MB)

Parameter	Test conditions	Value			Unit
		Typ ⁽¹⁾	Typ after 100K W/E cycles ⁽¹⁾	Max	
Bank erase	Primary bank (2 Mbytes)	32	36	46	s
	Primary bank (1 Mbytes)	16	18	23	s
	Secondary bank (128 Kbytes)	2.5	3	4	s
Sector erase	Of primary bank (64 Kbytes)	1300	1400	1800	ms
	Of secondary bank (16 Kbytes)	500	600	850	ms
Bank program	Primary bank (2 Mbytes)	15	20	22	s
	Primary bank (1 Mbytes)	7.5	10	11	s
	Secondary bank (128 Kbytes)	1060	1140	1380	ms
Sector program	Of primary bank (64 Kbytes)	500	520	640	ms
	Of secondary bank (16 Kbytes)	120	130	160	ms
Word program	Half word (16 bits)	8	9	11	μs

1. $V_{DD} = 1.8V$, $V_{DDQ} = 3.3V$, $T_A = 25^\circ\text{C}$.

Table 26. Flash memory endurance

Parameter	Test conditions	Value			Unit
		Min	Typ	Max	
Program/erase cycles	Per word	100K			cycles
Data retention		20			years

7.9 EMC characteristics

Susceptibility tests are performed on a sample basis during product characterization.

7.9.1 Functional EMS (electro magnetic susceptibility)

Based on a simple running application on the product (toggling 2 LEDs through I/O ports), the product is stressed by two electro magnetic events until a failure occurs (indicated by the LEDs).

- **ESD:** Electro-Static Discharge (positive and negative) is applied on all pins of the device until a functional disturbance occurs. This test conforms with the IEC 1000-4-2 standard.
- **FTB:** A Burst of Fast Transient voltage (positive and negative) is applied to V_{DD} , V_{DDQ} and V_{SS} through a 100pF capacitor, until a functional disturbance occurs. This test conforms with the IEC 1000-4-4 standard.

A device reset allows normal operations to be resumed. The test results are given in the table below based on the EMS levels and classes defined in application note AN1709.

Table 27. EMS data

Symbol	Parameter	Conditions	Severity/ Criteria ⁽¹⁾	Unit
V_{FESD}	Voltage limits to be applied on any I/O pin to induce a functional disturbance	$V_{DD}=1.8V$, $V_{DDQ}=3.3V$, $T_A=+25^{\circ}C$, $f_{OSC}/f_{CPUCLK}=4\text{ MHz}/96\text{MHz PLL}$	1B	kV
V_{FFTB}	Fast transient voltage burst limits to be applied through 100pF on V_{DD} and V_{DDQ} pins to induce a functional disturbance	$V_{DD}=1.8V$, $V_{DDQ}=3.3V$, $T_A=+25^{\circ}C$, $f_{OSC}/f_{CPUCLK}=4\text{ MHz}/96\text{ MHz PLL}$ conforms to IEC 1000-4-4	4A	

1. Data based on characterization results, not tested in production.

7.9.2 Electro magnetic interference (EMI)

Based on a simple application running on the product (toggling 2 LEDs through the I/O ports), the product is monitored in terms of emission. This emission test is in line with the norm SAE J 1752/3 which specifies the board and the loading of each pin.

Table 28. EMI data

Symbol	Parameter	Conditions	Monitored Frequency Band	Max vs. [f _{osc} /f _{cpuclk}]		Unit
				24 MHz / 48 MHz ⁽¹⁾	24 MHz / 96 MHz ⁽¹⁾	
S _{EMI}	Peak level	V _{DDQ} =3.3V, V _{DD} =1.8V, T _A =+25°C, LQFP128 package ⁽²⁾ conforming to SAE J 1752/3	0.1MHz to 30 MHz	14	10	dBμV
			30 MHz to 130 MHz	18	19	
			130 MHz to 1GHz	18	22	
			SAE EMI Level	4	4	-

1. Data based on characterization results, not tested in production.
2. BGA and LQFP devices have similar EMI characteristics.

7.9.3 Absolute maximum ratings (electrical sensitivity)

Based on two different tests (ESD and LU) using specific measurement methods, the product is stressed in order to determine its performance in terms of electrical sensitivity.

7.9.4 Electro-static discharge (ESD)

Electro-Static Discharges (3 positive then 3 negative pulses separated by 1 second) are applied to the pins of each sample according to each pin combination. The sample size depends on the number of supply pins in the device (3 parts*(n+1) supply pin). This test conforms to the JESD22-A114A/A115A standard. For more details, refer to the application note AN1181.

Table 29. ESD data

Symbol	Ratings	Conditions	Class	Maximum value ⁽¹⁾	Unit
V _{ESD(HBM)}	Electro-static discharge voltage (Human Body Model)	T _A =+25°C conforming to JESD22-A114	2	+/-2000	V
V _{ESD(CDM)}	Electro-static discharge voltage (Charged Device Model)	T _A =+25°C conforming to JESD22-C101	II	1000	

1. Data based on characterization results, not tested in production.

7.9.5 Static latch-up

Two complementary static tests are required on 10 parts to assess the latch-up performance.

- A supply overvoltage (applied to each power supply pin) and
- A current injection (applied to each input, output and configurable I/O pin) are performed on each sample.

This test conforms to the EIA/JESD 78 IC latch-up standard. For more details, refer to the application note AN1181.

7.9.6 Designing hardened software to avoid noise problems

EMC characterization and optimization are performed at component level with a typical application environment and simplified MCU software. It should be noted that good EMC performance is highly dependent on the user application and the software in particular.

Therefore it is recommended that the user applies EMC software optimization and prequalification tests in relation with the EMC level requested for his application.

Software recommendations:

The software flowchart must include the management of runaway conditions such as:

- Corrupted program counter
- Unexpected reset
- Critical Data corruption (control registers...)

Prequalification trials:

Most of the common failures (unexpected reset and program counter corruption) can be reproduced by manually forcing a low state on the RESET pin or the Oscillator pins for 1 second.

To complete these trials, ESD stress can be applied directly on the device, over the range of specification values. When unexpected behavior is detected, the software can be hardened to prevent unrecoverable errors occurring (see application note AN1015).

7.9.7 Electrical sensitivity

Table 30. Static latch-up data

Symbol	Parameter	Conditions	Class ⁽¹⁾
LU	Static latch-up class	T _A =+25°C conforming to JESD78A	II class A

1. Class description: A Class is an STMicroelectronics internal specification. All its limits are higher than the JEDEC specifications, that means when a device belongs to Class A it exceeds the JEDEC standard. B Class strictly covers all the JEDEC criteria (international standard).

7.10 I/O characteristics

$V_{DDQ} = 2.7 - 3.6V$, $V_{DD} = 1.65 - 2V$, $T_A = -40 / 85\text{ }^\circ\text{C}$ unless otherwise specified.

Table 31. I/O characteristics

Symbol	Parameter	Test conditions	Value			Unit
			Min	Typ	Max	
V_{IH}	Input high level	General inputs ⁽¹⁾	2.0		⁽²⁾	V
		RESET and TCK inputs ⁽¹⁾	$0.8V_{DDQ}$			
		TAMPER_IN input ⁽³⁾ (Run mode)	$V_{DDQ}/2$			
		TAMPER_IN input ⁽³⁾ (Standby mode)	$V_{BAT}/2$			
V_{IL}	Input low level	General inputs ⁽¹⁾			0.8	
		RESET and TCK inputs ⁽¹⁾			$0.2V_{DDQ}$	
		TAMPER_IN input ⁽³⁾ (Run mode)			$V_{DDQ}/2$	
		TAMPER_IN input ⁽³⁾ (Standby mode)			$V_{BAT}/2$	
V_{HYS}	Input hysteresis Schmitt trigger	General inputs ⁽⁴⁾	0.4			V
V_{OH}	Output high level High current pins	I/O ports 3 and 6: Push-Pull, $I_{OH} = 8\text{mA}$	$V_{DDQ}-0.7$			V
	Output high level Standard current pins	I/O ports 0,1,2,4,5,7,8,9: Push-Pull, $I_{OH} = 4\text{mA}$	$V_{DDQ}-0.7$			
	Output high level JTAG JTDO pin	$I_{OH} = -100\text{ }\mu\text{A}$	$V_{DDQ}-0.1$			
V_{OL}	Output low level High current pins	I/O ports 3 and 6: Push-Pull, $I_{OL} = 8\text{mA}$			0.4	V
	Output low level Standard current pins	I/O ports 0,1,2,4,5,7,8,9: Push-Pull, $I_{OL} = 4\text{mA}$			0.4	
	Output low level JTAG JTDO pin	$I_{OL} = 100\text{ }\mu\text{A}$			0.1	

1. Guaranteed by characterization, not tested in production.

2. Input pins are 5V tolerant, max input voltage is 5.5V

3. Guaranteed by design, not tested in production.

4. TAMPER_IN pin has no built-in hysteresis

7.11 External memory bus timings

$V_{DDQ} = 2.7 - 3.6V$, $V_{DD} = 1.65 - 2V$, $T_A = -40 / 85 \text{ }^\circ\text{C}$, $C_L = 30 \text{ pF}$ unless otherwise specified.

Table 32. EMI bus clock period

Symbol	Parameter ⁽¹⁾	Value ⁽²⁾
t_{BCLK}	EMI bus clock period	$1 / (f_{HCLK} \times \text{EMI_ratio})$

1. The internal EMI Bus clock signal is available externally only on LFBGA144 packages (ball M8), and not available on LQFP packages.
2. EMI_ratio = 1/ 2 by default (can be programmed to be 1 by setting the proper bits in the SCU_CLKCNTR register)

7.11.1 Asynchronous mode

Non Mux Write

Figure 18. Non-mux write timings

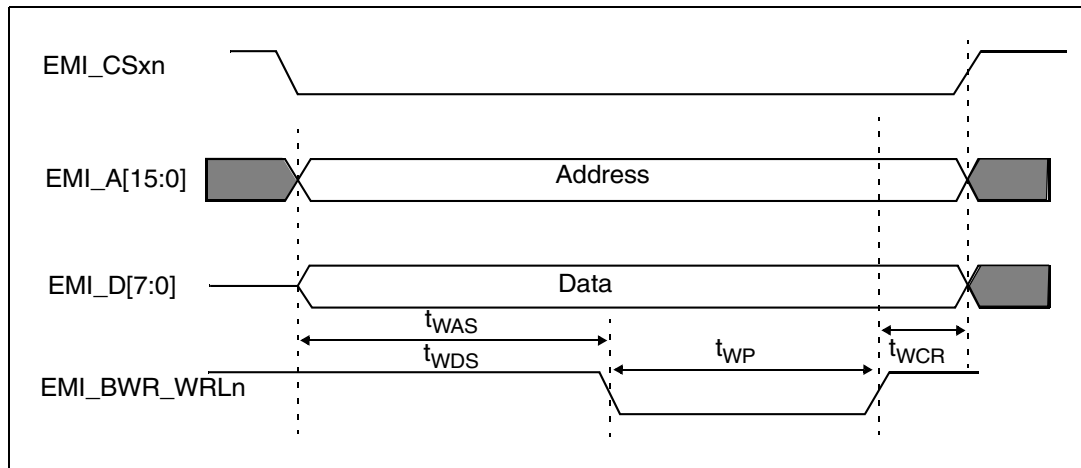

Table 33. EMI non-mux write operation

Symbol	Parameter	Value	
		Min	Max
t_{WCR}	WRn to CSn inactive	$(t_{BCLK}/2) - 2 \text{ ns}$	$(t_{BCLK}/2) + 2 \text{ ns}$
t_{WAS}	Write address setup time	$((\text{WSTWEN} + 1/2) \times t_{BCLK}) - 2 \text{ ns}$	$((\text{WSTWEN} + 1/2) \times t_{BCLK}) + 1 \text{ ns}$
t_{WDS}	Write data setup time	$((\text{WSTWEN} + 1/2) \times t_{BCLK}) - 5 \text{ ns}$	$((\text{WSTWEN} + 1/2) \times t_{BCLK})$
t_{WP}	Write pulse width	$(\text{WSTWR} - \text{WSTWEN} + 1) \times t_{BCLK} - 1 \text{ ns}$	$(\text{WSTWR} - \text{WSTWEN} + 1) \times t_{BCLK} + 1.5 \text{ ns}$

Non-mux read

Figure 19. Non-mux bus read timings

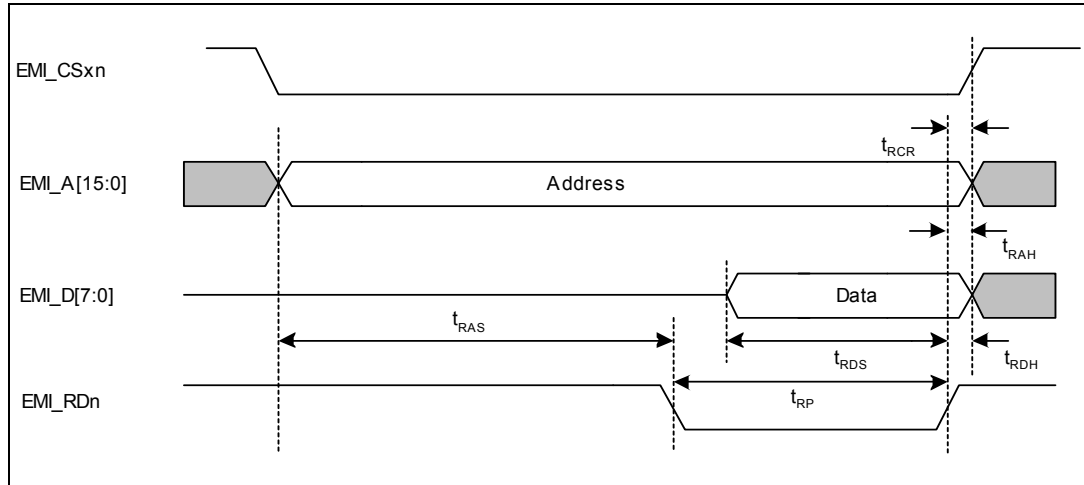

Table 34. EMI read operation

Symbol	Parameter	Value	
		Min	Max
t _{RCR}	Read to CSn inactive	0	1.5 ns
t _{RAS}	Read address setup time	$((WSTOEN) \times t_{BCLK}) - 1.5 \text{ ns}$	$(WSTOEN) \times t_{BCLK}$
t _{RDS}	Read data setup time	12.5	-
t _{RDH}	Read data hold time	0	-
t _{RP}	Read pulse width	$((WSTRD - WSTOEN + 1) \times t_{BCLK}) - 0.5 \text{ ns}$	$((WSTRD - WSTOEN + 1) \times t_{BCLK}) + 2 \text{ ns}$

Mux write

Figure 20. Mux write diagram

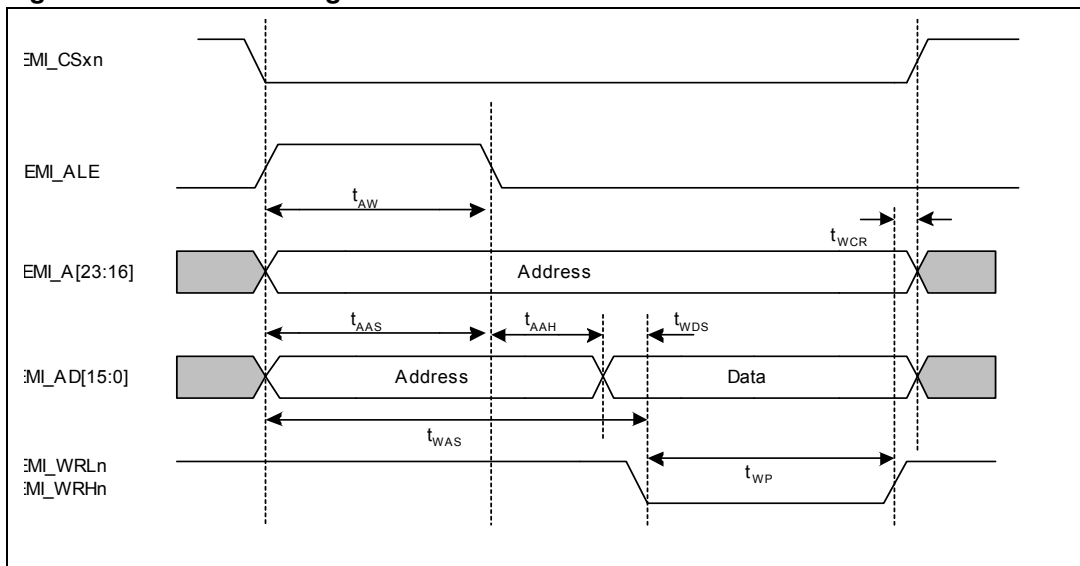

Table 35. Mux write times

Symbol	Parameter	Value	
		Min	Max
t_{WCR}	WRn to CSn inactive	$(t_{BCLK}/2) - 2ns$	$(t_{BCLK}/2) + 2ns$
t_{WAS}	Write address setup time	$(WSTWEN + 1/2) \times t_{BCLK} - 2.5 ns$	$(WSTWEN + 1/2) \times t_{BCLK} + 2 ns$
t_{WDS}	Write data setup time	$((WSTWEN - ALE_LENGTH) \times t_{BCLK}) - 2 ns$	$((WSTWEN - ALE_LENGTH) \times t_{BCLK}) + 1 ns$
t_{WP}	Write pulse width	$((WSTWR - WSTWEN + 1) \times t_{BCLK}) - 1 ns$	$((WSTWR - WSTWEN + 1) \times t_{BCLK}) + 1.5 ns$
t_{AW}	ALE pulse width	$(ALE_LENGTH \times t_{BCLK}) - 3.5 ns$	$(ALE_LENGTH \times t_{BCLK})$
t_{AAS}	Address to ALE setup time	$(ALE_LENGTH \times t_{BCLK}) - 3.5 ns$	$(ALE_LENGTH \times t_{BCLK})$
t_{AAH}	Address to ALE hold time	$(t_{BCLK}/2) - 1 ns$	$(t_{BCLK}/2) + 2 ns$

Mux read

Figure 21. Mux read diagram

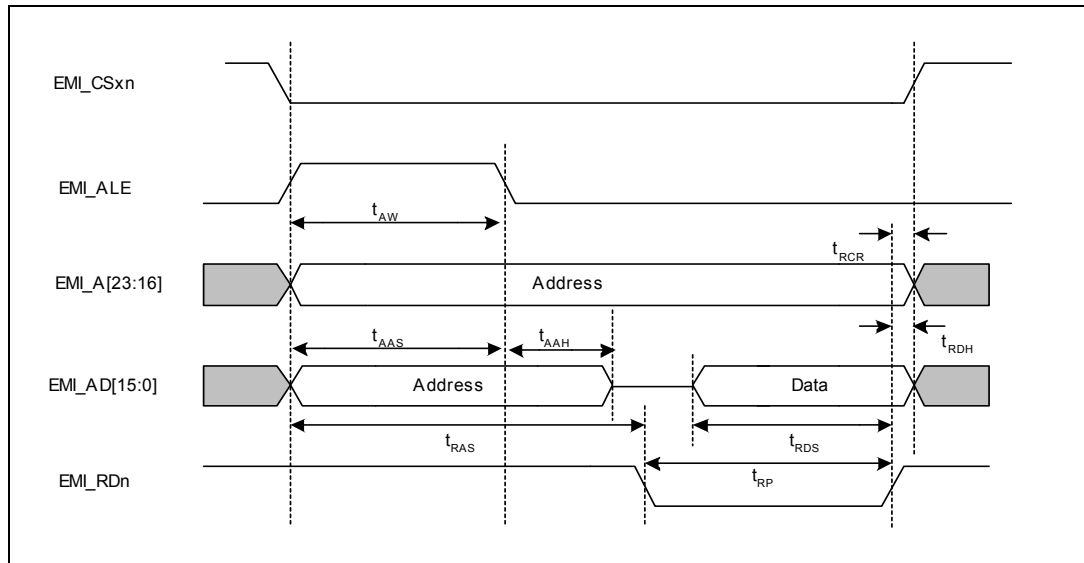

Table 36. Mux read times

Symbol	Parameter	Value	
		Min	Max
t _{RCR}	Read to CSn inactive	0	1.5 ns
t _{RAS}	Read address setup time	$((WSTOEN) \times t_{BCLK}) - 4 \text{ ns}$	$((WSTOEN) \times t_{BCLK})$
t _{RDS}	Read data setup time	12 ns	-
t _{RDH}	Read data hold time	0	
t _{RP}	Read pulse width	$((WSTRD - WSTOEN + 1) \times t_{BCLK}) - 0.5 \text{ ns}$	$((WSTRD - WSTOEN + 1) \times t_{BCLK}) + 2.5 \text{ ns}$
t _{AW}	ALE pulse width	$(ALE_LENGTH \times t_{BCLK}) - 3.5 \text{ ns}$	$(ALE_LENGTH \times t_{BCLK})$
t _{AAS}	Address to ALE setup time	$(ALE_LENGTH \times t_{BCLK}) - 3.5 \text{ ns}$	$(ALE_LENGTH \times t_{BCLK})$
t _{AAH}	Address to ALE hold time	$(t_{BCLK}/2) - 1 \text{ ns}$	$(t_{BCLK}/2) + 2 \text{ ns}$

Page mode read

Figure 22. Page mode read diagram

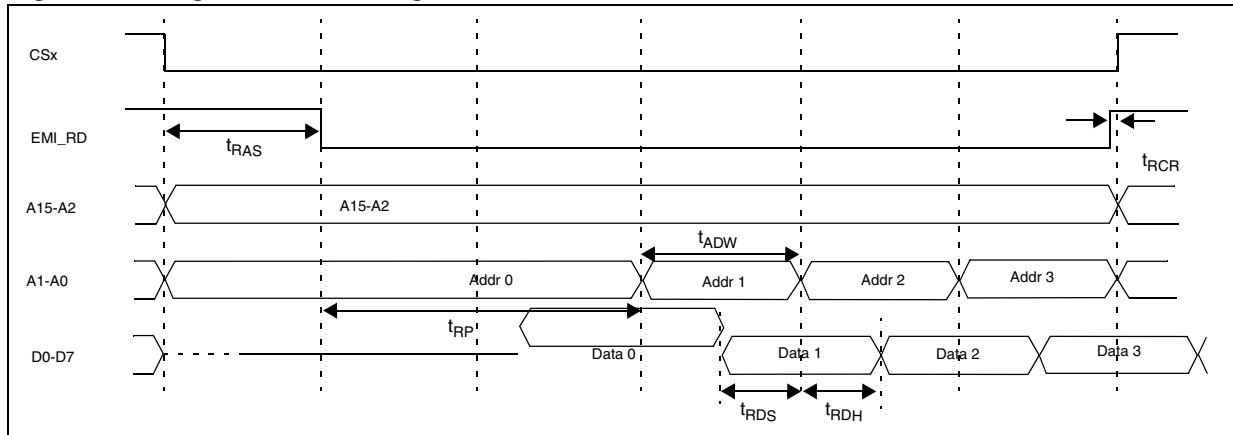

Table 37. Page mode read times

Symbol	Parameter	Value	
		Min	Max
t_{RDH}	Read data hold time	0	
t_{RDS}	Read data setup time	12 ns	-
t_{ADW}	ALE pulse width	$(t_{BCLK}) - 1.5 \text{ ns}$	$(t_{BCLK}) + 0.5 \text{ ns}$
t_{RAS}	Read address setup time	$((WSTOEN) \times t_{BCLK})$	$((WSTOEN) \times t_{BCLK}) + 2.5 \text{ ns}$
t_{RP}	Read pulse width	$((WSTRD - WSTOEN + 1) \times t_{BCLK})$	$((WSTRD - WSTOEN + 1) \times t_{BCLK}) + 2 \text{ ns}$
t_{RCR}	Read to CSn inactive	0	1 ns

7.11.2 Synchronous mode

Sync burst write

Figure 23. Sync burst write diagram

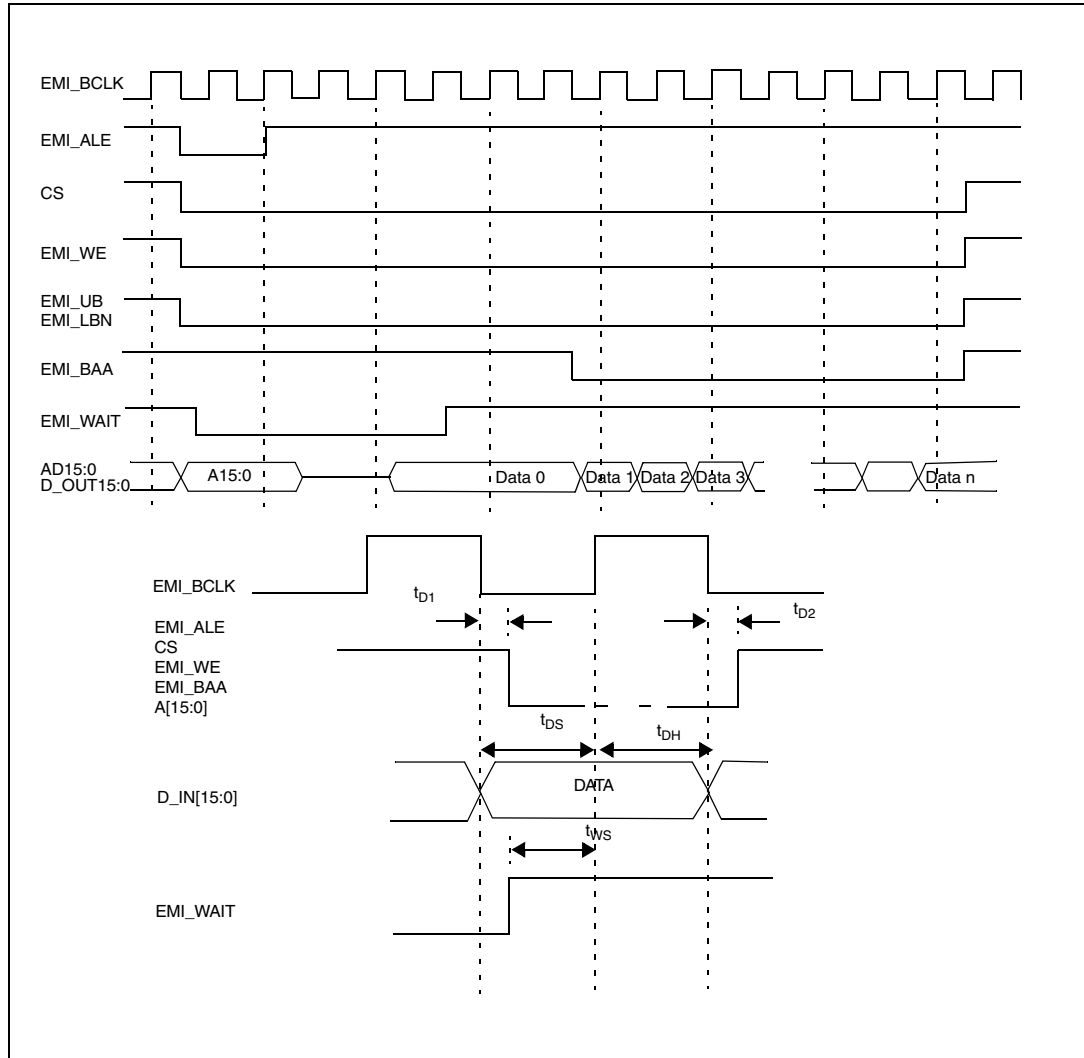

Table 38. Sync burst write times

Symbol	Parameter	Value	
		Min	Max
t_{D1BAA}	BAA t_{D1}	0	2 ns
t_{D2BAA}	BAA t_{D2}	0.5 ns	2.5 ns
t_{D1ALE}	ALE t_{D1}	1 ns	3.5 ns
t_{D2ALE}	ALE t_{D2}	$(t_{BCLK}/2) - 0.5$ ns	$(t_{BCLK}/2) + 3.5$ ns
t_{D1WR}	RD t_{D1}	0	2ns
t_{D2WR}	RD t_{D2}	0.5 ns	2.5 ns
t_{D1A}	Address t_{D1}	1.5 ns	4 ns
t_{D2A}	Address t_{D2}	2ns	4.5 ns
t_{D1CS}	CS t_{D1}	0.5ns	3 ns
t_{D2CS}	CS t_{D2}	1 ns	3.5 ns
t_{WS}	WAIT setup time	3 ns	6 ns
t_{DS}	Data setup time	$(t_{BCLK}/2) - 3.5$ ns	$(t_{BCLK}/2) + 0.5$ ns
t_{DH}	Data hold time	$(t_{BCLK}/2) - 1$ ns	$(t_{BCLK}/2) + 3.5$ ns

Sync burst read

Figure 24. Sync burst read diagram

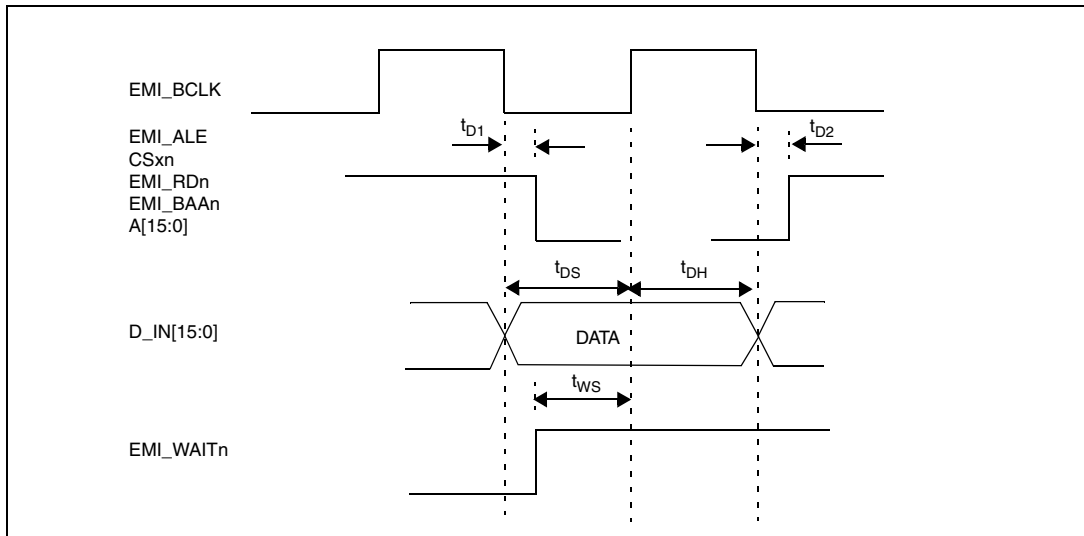

Table 39. Sync burst read times

Symbol	Parameter	Value	
		Min	Max
t_{D1BAA}	BAA t_{D1}	0 ns	2 ns
t_{D2BAA}	BAA t_{D2}	0.5ns	2.5 ns
t_{D1ALE}	ALE t_{D1}	1 ns	3.5 ns
t_{D2ALE}	ALE t_{D2}	$(t_{BCLK}/2)+0.5$ ns	$(t_{BCLK}/2)+3$ ns
t_{D1RD}	RD t_{D1}	0	2 ns
t_{D2RD}	RD t_{D2}	0.5 ns	2.5 ns
t_{D1A}	Address t_{D1}	2 ns	4 ns
t_{D2A}	Address t_{D2}	2.5 ns	3.5 ns
t_{D1CS}	CS t_{D1}	0.5 ns	3 ns
t_{D2CS}	CS t_{D2}	1 ns	3.5 ns
t_{WS}	WAIT set up time	1 ns	4 ns
t_{DS}	Data setup time	4.5 ns	-
t_{DH}	Data hold time	0	-

7.12 Communication interface electrical characteristics

7.12.1 10/100 Ethernet MAC electrical characteristics

$V_{DDQ} = 2.7 - 3.6V$, $V_{DD} = 1.65 - 2V$, $T_A = -40 / 85\text{ }^\circ\text{C}$ unless otherwise specified.

Ethernet MII interface timings

Figure 25. MII_RX_CLK and MII_TX_CLK timing diagram

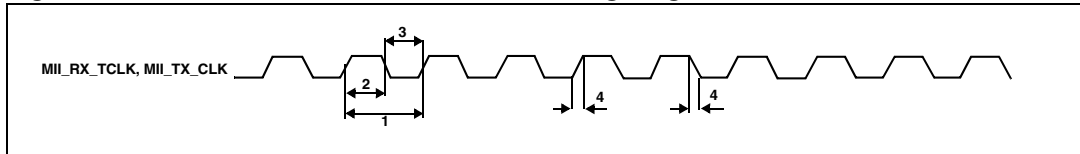

Table 40. MII_RX_CLK and MII_TX_CLK timing table

Symbol	Parameter	Symbol	Value		Unit
			Min	Max	
1	Cycle time	$t_c(\text{CLK})$	40		ns
2	Pulse duration high	$t_{\text{HIGH}}(\text{CLK})$	40%	60%	
3	Pulse duration low	$t_{\text{LOW}}(\text{CLK})$	40%	60%	
4	Transition time	$t_t(\text{CLK})$		1	ns

Figure 26. MDC timing diagram

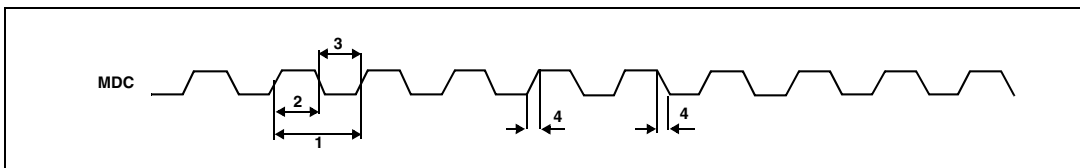

Table 41. MDC timing table

Symbol	Parameter	Symbol	Value		Unit
			Min	Max	
1	Cycle time	$t_c(\text{MDC})$	266		ns
2	Pulse duration high	$t_{\text{HIGH}}(\text{MDC})$	40%	60%	
3	Pulse duration low	$t_{\text{LOW}}(\text{MDC})$	40%	60%	
4	Transition time	$t_t(\text{MDC})$		1	ns

Ethernet MII management timings

Figure 27. Ethernet MII management timing diagram

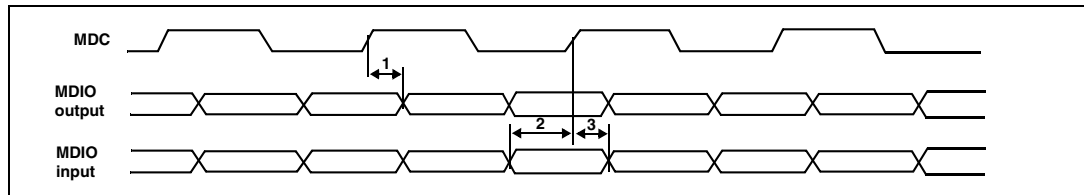

Table 42. Ethernet MII management timing table

Symbol	Parameter	Symbol	Value		Unit
			Min	Max	
1	MDIO delay from rising edge of MDC	$t_c(\text{MDIO})$		2.83	ns
2	MDIO setup time to rising edge of MDC	$T_{su}(\text{MDIO})$	2.70		ns
3	MDIO hold time from rising edge of MDC	$T_h(\text{MDIO})$	-2.03		ns

Ethernet MII transmit timings

Figure 28. Ethernet MII transmit timing diagram

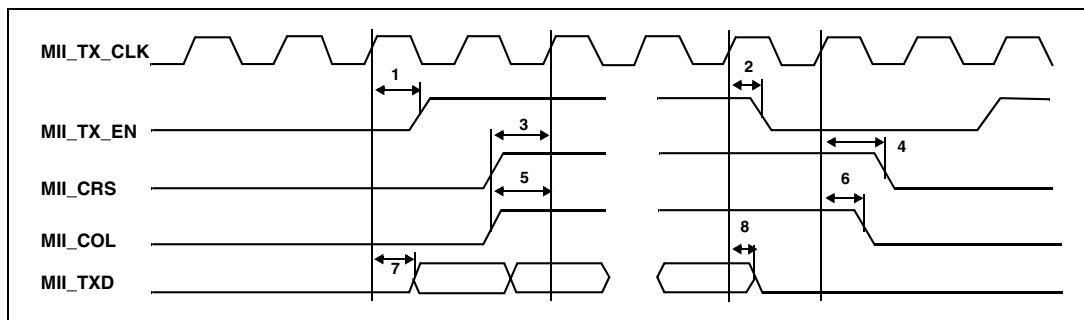

Table 43. Ethernet MII transmit timing table

Symbol	Parameter	Symbol	Value		Unit
			Min	Max	
1	MII_TX_CLK high to MII_TX_EN valid	$t_{VAL}(\text{MII_TX_EN})$		4.20	ns
2	MII_TX_CLK high to MII_TX_EN invalid	$T_{inval}(\text{MII_TX_EN})$		4.86	ns
3	MII_CRS valid to MII_TX_CLK high	$T_{su}(\text{MII_CRS})$	0.61		ns
4	MII_TX_CLK high to MII_CRS invalid	$T_h(\text{MII_CRS})$	0.00		ns
5	MII_COL valid to MII_TX_CLK high	$T_{su}(\text{MII_COL})$	0.81		ns

Table 43. Ethernet MII transmit timing table

Symbol	Parameter	Symbol	Value		Unit
			Min	Max	
6	MII_TX_CLK high to MII_COL invalid	$T_h(\text{MII_COL})$	0.00		ns
7	MII_TX_CLK high to MII_TXD valid	$t_{\text{VAL}}(\text{MII_TXD})$		5.02	ns
8	MII_TXCLK high to MII_TXD invalid	$T_{\text{inval}}(\text{MII_TXD})$		5.02	ns

Ethernet MII receive timings

Figure 29. Ethernet MII receive timing diagram

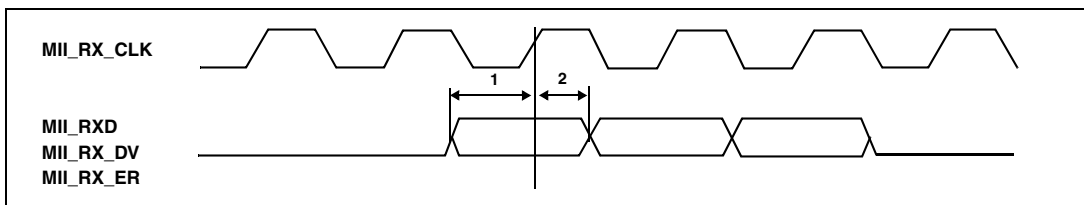

Table 44. Ethernet MII receive timing table

Symbol	Parameter	Symbol	Value		Unit
			Min	Max	
1	MII_RXD valid to MII_RX_CLK high	$T_{\text{su}}(\text{MII_RXD})$	0.81		ns
2	MII_RX_CLK high to MII_RXD invalid	$T_h(\text{MII_RXD})$	0.00		ns

7.12.2 USB electrical interface characteristics

USB 2.0 Compliant in Full Speed Mode

7.12.3 CAN interface electrical characteristics

Conforms to CAN 2.0B protocol specification

7.12.4 I²C electrical characteristics

$V_{DDQ} = 2.7 - 3.6V$, $V_{DD} = 1.65 - 2V$, $T_A = -40 / 85\text{ }^{\circ}C$ unless otherwise specified.

Table 45. I²C electrical characteristics

Symbol	Parameter	Standard I ² C		Fast I ² C		Unit
		Min	Max	Min	Max	
t_{BUF}	Bus free time between a STOP and START condition	4.7		1.3		μs
$t_{HD:STA}$	Hold time START condition. After this period, the first clock pulse is generated ⁽¹⁾	4.0		0.6		μs
t_{LOW}	Low period of the SCL clock	4.7		1.3		μs
t_{HIGH}	High period of the SCL clock	4.0		0.6		μs
$t_{SU:STA}$	Setup time for a repeated START condition	4.7		0.6		μs
$t_{HD:DAT}$	Data hold time ⁽²⁾	0		0		ns
$t_{SU:DAT}$	Data setup time	250		100		ns
t_R	Rise time of both SDA and SCL signals		1000	$20+0.1C_b$ ⁽³⁾	300	ns
t_F	Fall time of both SDA and SCL signals		300	$20+0.1C_b$ ⁽³⁾	300	ns
$t_{SU:STO}$	Setup time for STOP condition	4.0		0.6		μs
C_b	Capacitive load for each bus line		400		400	pF

1. The maximum hold time of the START condition has only to be met if the interface does not stretch the low period of SCL signal
2. The device must internally provide a hold time of at least 300 ns for the SDA signal in order to bridge the undefined region of the falling edge of SCL.
3. C_b = total capacitance of one bus line in pF

7.12.5 SPI electrical characteristics

$V_{DDQ} = 2.7 - 3.6V$, $V_{DD} = 1.65 - 2V$, $T_A = -40 / 85\text{ }^\circ\text{C}$ unless otherwise specified.

Table 46. SPI electrical characteristics

Symbol	Parameter	Test conditions	Value		Unit
			Typ	Max	
f_{SCLK} $1/t_c(SCLK)$	SPI clock frequency	Master		24	MHz
		Slave		4	
$t_r(SCLK)$ $t_f(SCLK)$	SPI clock rise and fall times	50pF load	0.1		V/ns
$t_{su(SS)}$	SS setup time	Slave	1		t_{PCLK}
$t_h(SS)$	SS hold time	Slave	1		
$t_w(SCLKH)$ $t_w(SCLKL)$	SCLK high and low time	Master	1		
		Slave			
$t_{su(MI)}$ $t_{su(SI)}$	Data input setup time	Master	TBD		
		Slave	5		
$t_h(MI)$ $t_h(SI)$	Data input hold time	Master	TBD		
		Slave	6		
$t_a(SO)$	Data output access time	Slave		6	
$t_{dis(SO)}$	Data output disable time	Slave		6	
$t_v(SO)$	Data output valid time	Slave (after enable edge)		6	
$t_h(SO)$	Data output hold time		0		
$t_v(MO)$	Data output valid time	Master (before capture edge)	0.25		
$t_h(MO)$	Data output hold time		0.25		

Figure 30. SPI slave timing diagram with CPHA=0

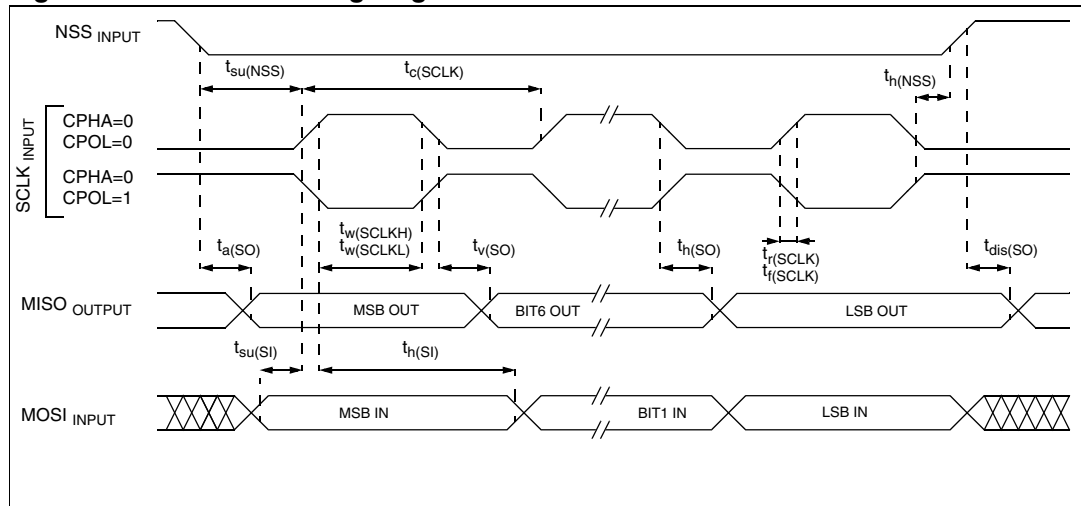

Figure 31. SPI slave timing diagram with CPHA=1

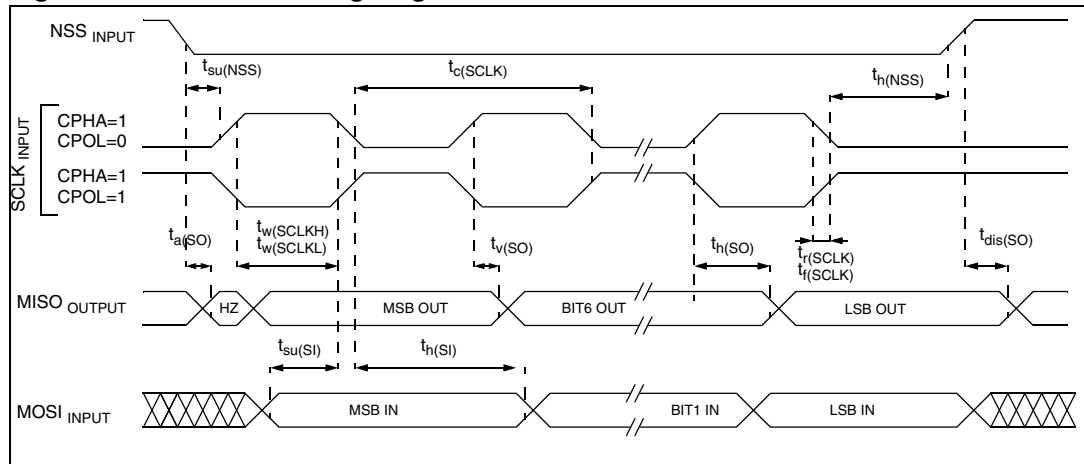
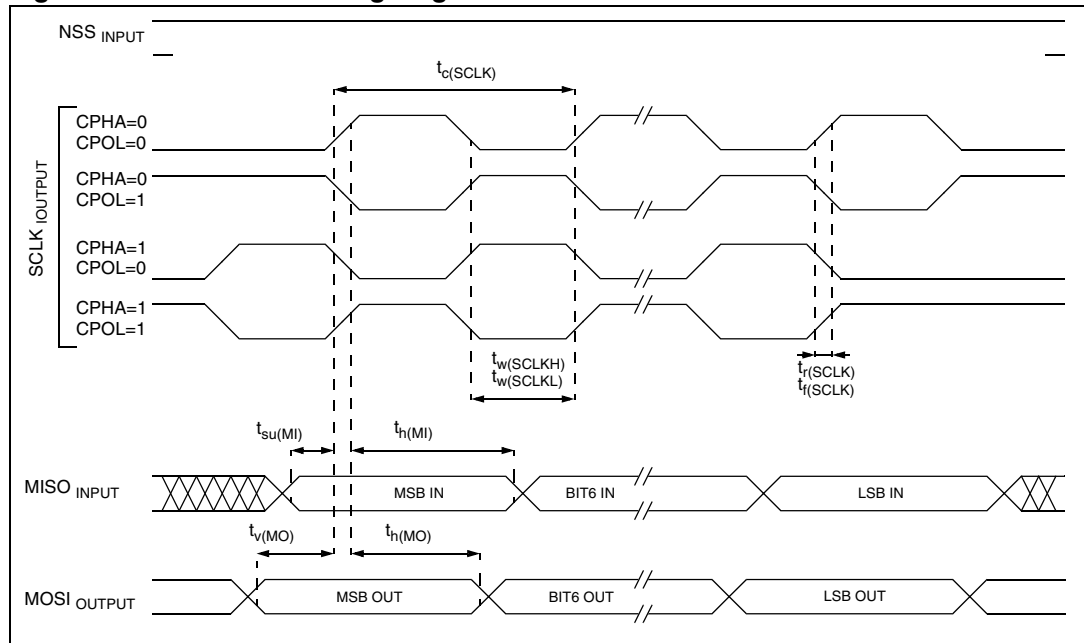

Figure 32. SPI master timing diagram



7.13 ADC electrical characteristics

$V_{DDQ} = 2.7 - 3.6V$, $V_{DD} = 1.65 - 2V$, $T_A = -40 / 85 \text{ }^\circ\text{C}$ unless otherwise specified.

Table 47. General ADC electrical characteristics

Symbol	Parameter ⁽¹⁾	Test conditions	Value			Unit
			Min	Typ	Max	
V_{AIN}	Input voltage range		0		AV_{REF}	V
RES	Resolution				10	Bits
N_{CH}	Number of input channels				8	N
f_{ADC}	ADC clock frequency				25	MHz
$t_{POR(ADC)}$	POR bit set to Standby mode				500	ms
$t_{ck_off(ADC)}$	ADC clock disabled before conversion ⁽²⁾				1	ms
t_{STAB}	Stabilization time				15	μs
C_{IN}	Input capacitance			5		pF
E_D	Differential non-linearity	⁽³⁾ ⁽⁴⁾		1	3	LSB ⁽⁵⁾
E_L	Integral non-linearity	⁽³⁾		3	6	LSB ⁽⁵⁾
E_O	Offset error	⁽³⁾		3	6	LSB ⁽⁵⁾
E_G	Gain error	⁽³⁾		0.5	2	LSB ⁽⁵⁾
E_T	Total unadjusted error	⁽³⁾		4	6	LSB ⁽⁵⁾
I_{ADC}	Power consumption			4.6		mA
I_{VREF}	Current on VREF input pin	⁽⁶⁾ ⁽⁷⁾			920	μA

1. Guaranteed by design, not tested in production.
2. The ADC clock can be disabled by setting the ADC bit in the SCU_PCGR1 register or by setting the ACG bit in the SCU_GPIOANA register (for Rev H and higher)
3. Conditions: $AV_{SS} = 0 \text{ V}$, $AV_{DD} = 3.3 \text{ V}$, $f_{ADC} = 25 \text{ MHz}$.
4. The A/D is monotonic, there are no missing codes.
5. $1 \text{ LSB} = (AV_{DD} - AV_{SS})/1024$
6. Data based on characterization, not tested in production.
7. Conditions: $V_{DD}=1.8 \text{ V}$, $f_{CPU}=96 \text{ MHz}$, $f_{ADC}=24 \text{ MHz}$

Table 48. ADC conversion time (silicon Rev G)

Symbol	Parameter ^{(1) (2)}	Test conditions	Value			Unit
			Min	Typ	Max	
t _{CONV(S)}	Single mode conversion time		2*16/f _{ADC}		3*16/f _{ADC}	μs
		f _{ADC} = 24 MHz	1.33		2	
TR(S)	Single mode throughput rate ⁽³⁾	f _{ADC} = 24 MHz			500	ksps
t _{CONV(C)}	Continuous mode conversion time ⁽⁴⁾			1*16/f _{ADC}		μs
		f _{ADC} = 24 MHz		0.66		μs
TR(C)	Continuous mode throughput rate	f _{ADC} = 24 MHz		1500		ksps

1. Guaranteed by design, not tested in production.
2. Parameters in this table apply to devices with silicon Rev G. Refer to [Table 5](#) for device rev identification in OTP memory and to [Section 8: Device marking](#).
3. Value obtained on conversions started by trigger in single mode
4. All successive conversions in continuous and scan modes.

Table 49. ADC conversion time (silicon Rev H and higher)

Symbol	Parameter ^{(1) (2)}	Test conditions	Value			Unit
			Min	Typ	Max	
t _{CONV(S)}	Single mode conversion time		1*16/f _{ADC}		2*16/f _{ADC}	μs
		f _{ADC} = 24 MHz	0.66		1.33	
TR(S)	Single mode throughput rate ⁽³⁾	f _{ADC} = 24 MHz			750	ksps
t _{CONV(C)}	Continuous mode conversion time ⁽⁴⁾			1*16/f _{ADC}		μs
		f _{ADC} = 24 MHz		0.66		μs
TR(C)	Continuous mode throughput rate	f _{ADC} = 24 MHz		1500		ksps
t _{CONV(FT)}	Fast trigger mode conversion time ⁽⁵⁾			1*16/f _{ADC}		μs
		f _{ADC} = 24 MHz		0.66		μs
TR(FT)	Fast trigger mode throughput rate ⁽⁶⁾	f _{ADC} = 24 MHz	100		1200	ksps

1. Guaranteed by design, not tested in production.
2. Parameters in this table apply to devices with silicon Rev H and higher. Refer to [Table 5](#) for device rev identification in OTP memory and to [Section 8: Device marking](#).
3. Value obtained from conversions started by trigger in single mode
4. All successive conversions in continuous and scan modes.
5. Conversion started by trigger when automatic clock gated mode enabled. Fast trigger mode is available only in devices with silicon Rev H and higher.
6. Value obtained from conversions started by fast trigger in single mode

Figure 33. ADC conversion characteristics

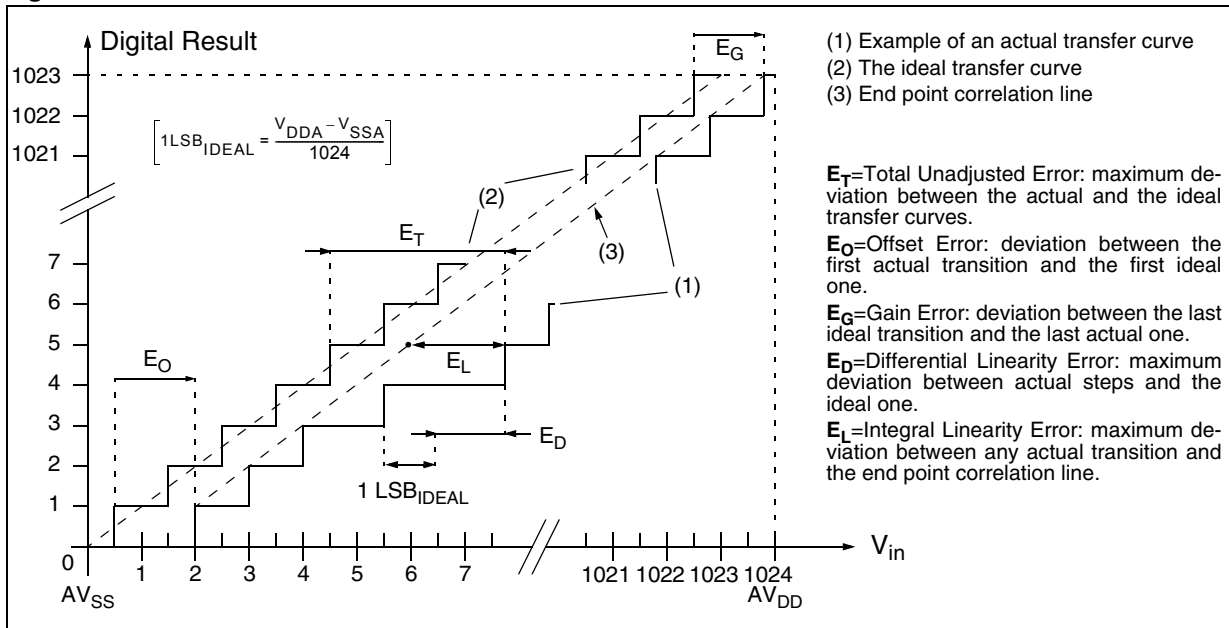

- (1) Example of an actual transfer curve
- (2) The ideal transfer curve
- (3) End point correlation line

E_T =Total Unadjusted Error: maximum deviation between the actual and the ideal transfer curves.

E_O =Offset Error: deviation between the first actual transition and the first ideal one.

E_G =Gain Error: deviation between the last ideal transition and the last actual one.

E_D =Differential Linearity Error: maximum deviation between actual steps and the ideal one.

E_L =Integral Linearity Error: maximum deviation between any actual transition and the end point correlation line.

8 Device marking

8.1 STR91xFAx32 / STR91xFAx42 / STR91xFAx44

Figure 34. Device marking for revision G
LQFP80 and LQFP128 packages

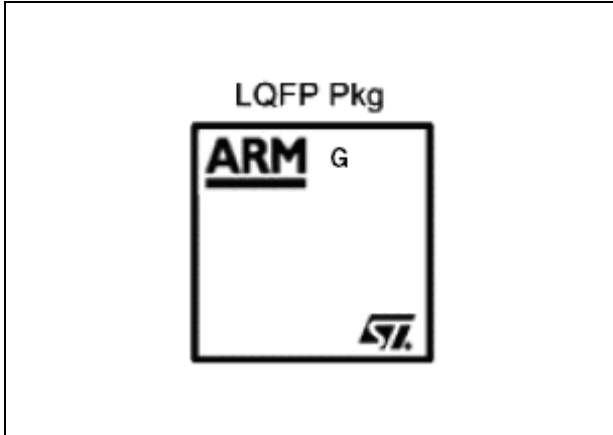

Figure 35. Device marking for revision G
LFBGA144 packages

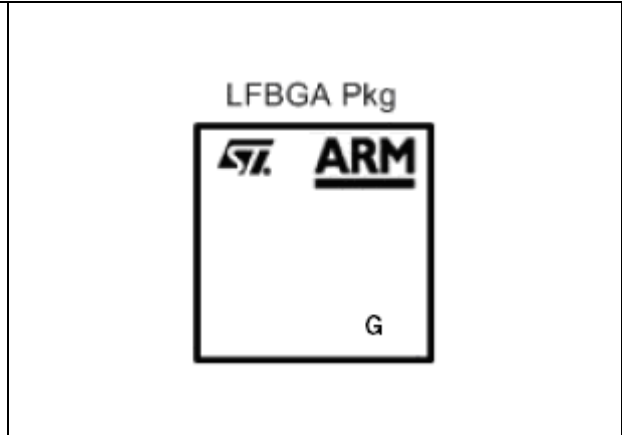

Figure 36. Device marking for revision H
LQFP80 and LQFP128 packages

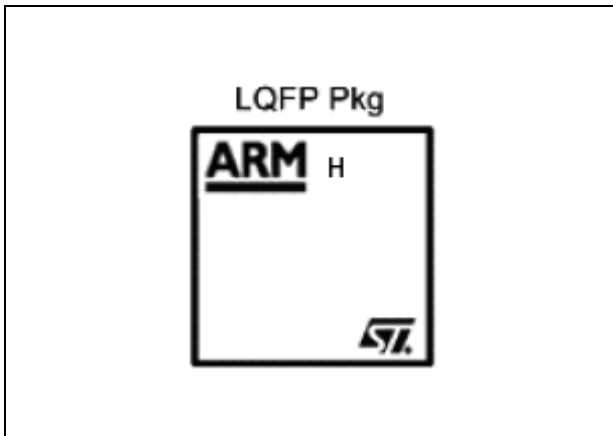
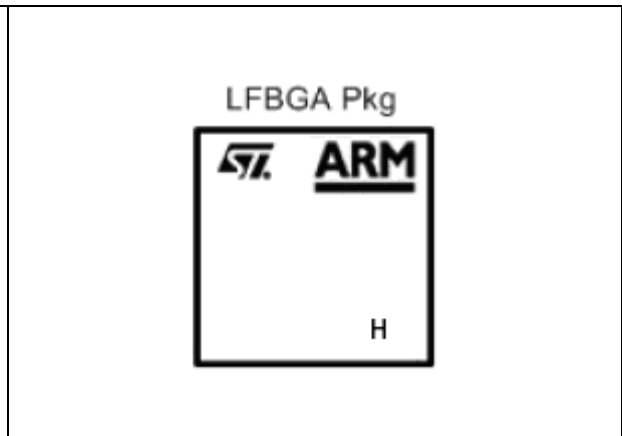

Figure 37. Device marking for revision H
LFBGA144 packages



8.2 STR91xFx46 / STR91xFx47

Figure 38. Device marking for revision A
LQFP80 and LQFP128 packages

Figure 39. Device marking for revision A
LFBGA144 packages

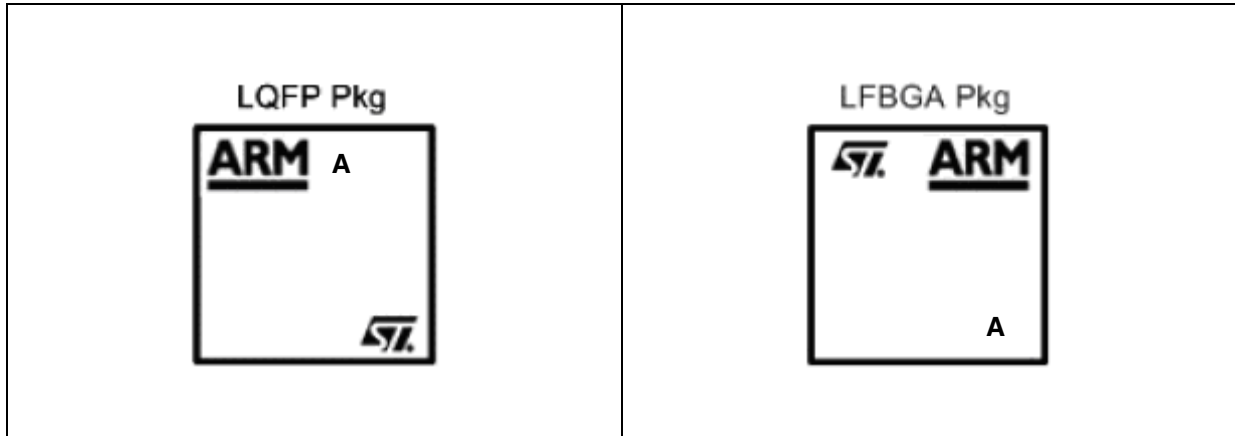

9 Package mechanical data

Figure 40. 80-pin low profile quad flat package (LQFP80) outline

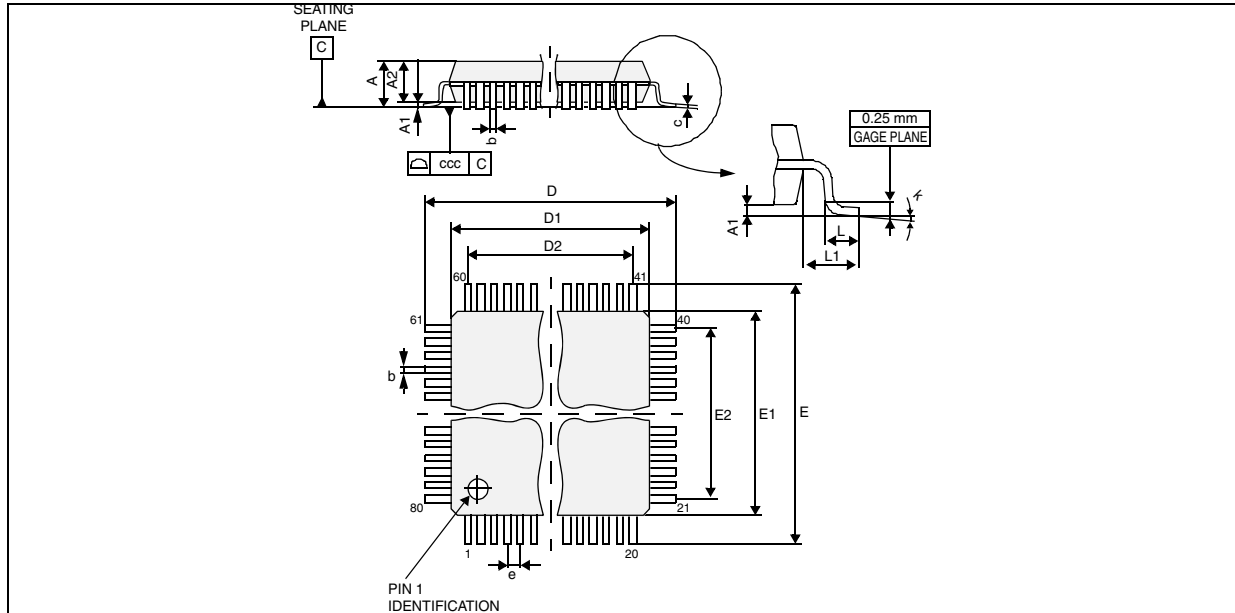

Table 50. 80-pin low profile quad flat package (LQFP80) mechanical data

Dim.	mm			inches ⁽¹⁾		
	Min	Typ	Max	Min	Typ	Max
A			1.60			0.0630
A1	0.05	0.10	0.15	0.0020	0.0039	0.0059
A2	1.35	1.40	1.45	0.0531	0.0551	0.0571
b	0.17	0.22	0.27	0.0067	0.0087	0.0106
c	0.09		0.20	0.0035		0.0079
D	13.80	14.00	14.20	0.5433	0.5512	0.5591
D1	11.90	12.00	12.10	0.4685	0.4724	0.4764
D2		9.50			0.3740	
E	13.80	14.00	14.20	0.5433	0.5512	0.5591
E1	11.90	12.00	12.10	0.4685	0.4724	0.4764
E2		9.50			0.3740	
e		0.50			0.0197	
L	0.45	0.60	0.75	0.0177	0.0236	0.0295
L1		1.00			0.039	
k	0d		7d	0d		7d
ddd			0.08			0.0031

1. Values in inches are converted from mm and rounded to 4 decimal digits.

Figure 41. 128-pin low profile quad flat package (LQFP128) outline

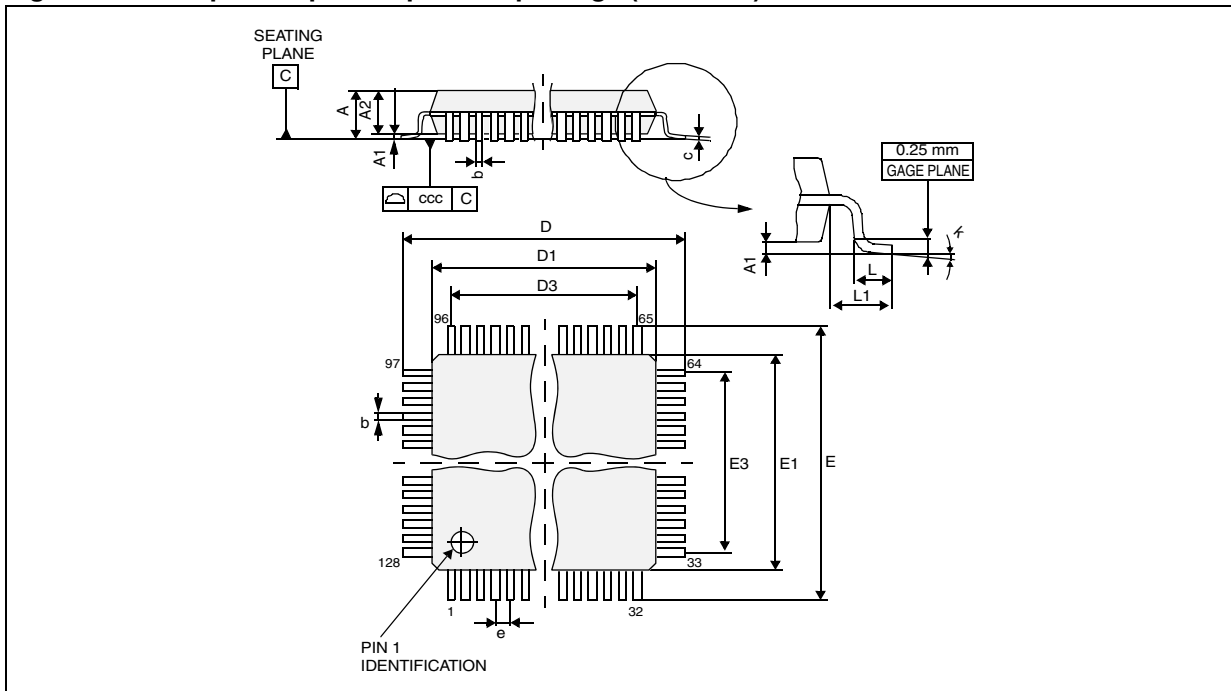

Table 51. 128-pin low profile quad flat package (LQFP128) mechanical data

Dim.	mm			inches ⁽¹⁾		
	Min	Typ	Max	Min	Typ	Max
A			1.60			0.0630
A1	0.05		0.15	0.0020		0.0059
A2	1.35	1.40	1.45	0.0531	0.0551	0.0571
b	0.13	0.18	0.23	0.0051	0.0071	0.0091
c	0.09		0.20	0.0035		0.0079
D	15.80	16.00	16.20	0.6220	0.6299	0.6378
D1	13.80	14.00	14.20	0.5433	0.5512	0.5591
D3		12.40			0.4882	
E	15.80	16.00	16.20	0.6220	0.6299	0.6378
E1	13.80	14.00	14.20	0.5433	0.5512	0.5591
E3		12.40			0.4882	
e		0.40			0.0157	
L	0.45	0.60	0.75	0.0177	0.0236	0.0295
L1		1.00			0.0394	
k	0d	3.5d	7d	0d	3.5d	7d
ccc			0.08			0.0031

1. Values in inches are converted from mm and rounded to 4 decimal digits.

Figure 42. 144-ball low profile fine pitch ball grid array package (LFBGA144) outline

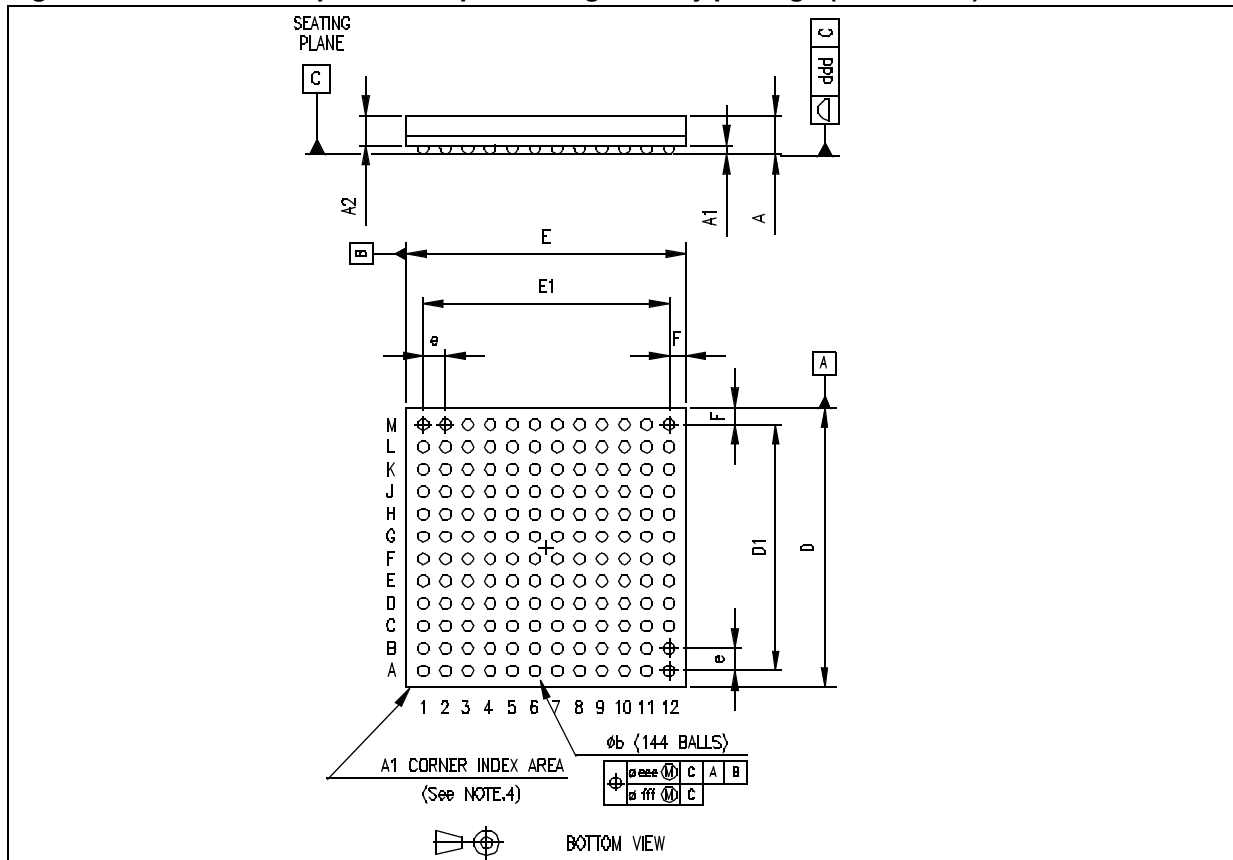
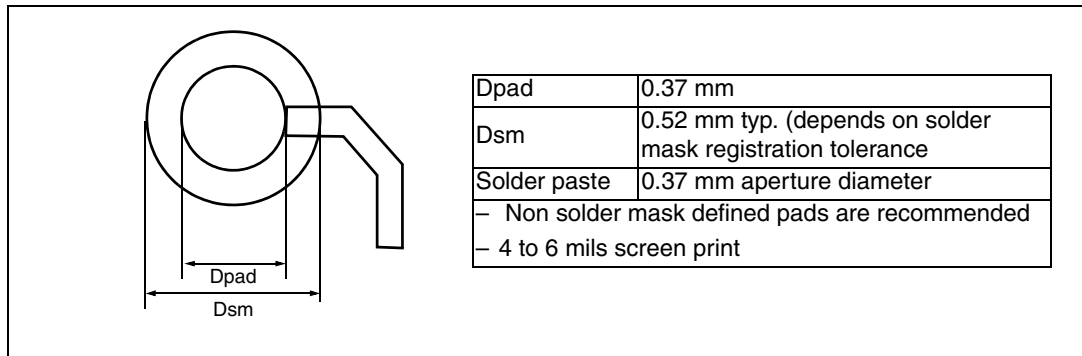

Table 52. 144-ball low profile fine pitch ball grid array package (LFBGA144) mechanical data

Dim.	mm			inches ⁽¹⁾		
	Min	Typ	Max	Min	Typ	Max
A	1.21		1.70	0.0476		0.0669
A1	0.21			0.0083		
A2		1.085			0.0427	
b	0.35	0.40	0.45	0.0138	0.0157	0.0177
D	9.85	10.00	10.15	0.3878	0.3937	0.3996
D1		8.80			0.3465	
E	9.85	10.00	10.15	0.3878	0.3937	0.3996
E1		8.80			0.3465	
e		0.80			0.0315	
F		0.60			0.0236	
ddd			0.10			0.0039
eee			0.15			0.0059
fff			0.08			0.0031

1. Values in inches are converted from mm and rounded to 4 decimal digits.

Figure 43. Recommended PCB design rules (0.80/0.75 mm pitch BGA)



9.1 ECOPACK

In order to meet environmental requirements, ST offers these devices in different grades of ECOPACK® packages, depending on their level of environmental compliance. ECOPACK® specifications, grade definitions and product status are available at: www.st.com. ECOPACK® is an ST trademark.

9.2 Thermal characteristics

The average chip-junction temperature, T_J must never exceed 125 °C.

The average chip-junction temperature, T_J , in degrees Celsius, may be calculated using the following equation:

$$T_J = T_A + (P_D \times \Theta_{JA}) \tag{1}$$

Where:

- T_A is the ambient temperature in °C,
- Θ_{JA} is the package junction-to-ambient thermal resistance, in °C/W,
- P_D is the sum of P_{INT} and $P_{I/O}$ ($P_D = P_{INT} + P_{I/O}$),
- P_{INT} is the product of I_{DD} and V_{DD} , expressed in Watts. This is the Chip Internal Power.

$P_{I/O}$ represents the power dissipation on input and output pins;

Most of the time for the applications $P_{I/O} < P_{INT}$ and may be neglected. On the other hand, $P_{I/O}$ may be significant if the device is configured to drive continuously external modules and/or memories. The worst case P_{INT} of the STR91xFA is 500 mW ($I_{DD} \times V_{DD}$, or 250 mA x 2.0 V).

An approximate relationship between P_D and T_J (if $P_{I/O}$ is neglected) is given by:

$$P_D = K / (T_J + 273 \text{ °C}) \tag{2}$$

Therefore (solving equations 1 and 2):

$$K = P_D \times (T_A + 273 \text{ °C}) + \Theta_{JA} \times P_D^2 \tag{3}$$

Where:

- K is a constant for the particular part, which may be determined from equation (3) by measuring P_D (at equilibrium) for a known T_A . Using this value of K, the values of P_D and T_J may be obtained by solving equations (1) and (2) iteratively for any value of T_A .

Table 53. Thermal characteristics

Symbol	Parameter	Value	Unit
Θ_{JA}	Thermal resistance junction-ambient LQFP 80 - 12 x 12 mm / 0.5 mm pitch	41.5	°C/W
Θ_{JA}	Thermal resistance junction-ambient LQFP128 - 14 x 14 mm / 0.4 mm pitch	38	°C/W
Θ_{JA}	Thermal resistance junction-ambient LFBGA 144 - 10 x 10 x 1.7 mm	36.5	°C/W

10 Ordering information

Table 54. Ordering information scheme

Example:	STR9	1	2	F	A	W	4	4	X	6	T
Family ARM9 microcontroller family											
Series 1 = STR9 series 1											
Feature set 0 = CAN, UART, IrDA, I2C, SSP 1 = USB, CAN, UART, IrDA, I2C, SSP 2 = USB, CAN, UART, IrDA, I2C, SSP, ETHERNET											
Memory type F = Flash											
Revision at product level A = Revision A											
No. of pins M = 80 W = 128 Z = 144											
SRAM size 3 = 64 Kbytes 4 = 96 Kbytes											
Primary memory size 2 = 256 Kbytes 6= 1024 Kbytes 4 = 512 Kbytes 7= 2048 Kbytes											
Package X = plastic LQFP H = LFBGA											
Temperature range 6 = -40 to 85°C											
Shipping option T = Tape & reel packing											
For a list of available options (e.g. speed, package) or for further information on any aspect of this device, please contact the ST Sales Office nearest to you.											

11 Revision history

Table 55. Document revision history

Date	Revision	Changes
09-May-2007	1	Initial release
26-Nov-2007	2	Updated Standby current in Table 15: Supply current characteristics on page 63 Added Section 7.1: Parameter conditions on page 57 Added Section 7.7.2: X1_CPU external clock source on page 66 Updated Section 7.11: External memory bus timings on page 74 Added Figure 14: LVD reset delay case 3 on page 62 Added Table 48 and Table 49 in ADC characteristics section Added min/max values for E, D, E1, D1 in Figure 41 on page 94
14-May-2008	3	Added 1MB and 2M devices, creating merged datasheet from separate STR91xFAx32, 42, 44, 46 and 47 devices. Added STR912FAW32 to Table 1: Device summary on page 1 Added paragraph on voltage supply shutdown in Section 3.12 on page 24 Removed DMA feature for I2C in Section 3.21 on page 33 Updated Sleep mode current in Table 10: Current characteristics on page 59 Added Table 16: Typical current consumption at 25 °C on page 64 Updated operating conditions for V_{DD} and f_{CPUCLK} in Section 7.3 on page 60 and Section 7.7 on page 65 Changed SPI master t_{SU} and $t_{H to TBD}$ in Section Table 46. on page 86
17-Jul-2008	4	Updated Section 3.10.6 on page 22 Updated Table 11: Operating conditions on page 60 Updated $I_{SLEEP(IDDQ)}$ in Table 15: Supply current characteristics on page 63 Updated Table 17: Internal clock frequencies on page 65 Updated Table 31: I/O characteristics on page 73
22-Dec-2008	5	Updated Section 7.7.3 on page 67 . Small text changes.

Please Read Carefully:

Information in this document is provided solely in connection with ST products. STMicroelectronics NV and its subsidiaries ("ST") reserve the right to make changes, corrections, modifications or improvements, to this document, and the products and services described herein at any time, without notice.

All ST products are sold pursuant to ST's terms and conditions of sale.

Purchasers are solely responsible for the choice, selection and use of the ST products and services described herein, and ST assumes no liability whatsoever relating to the choice, selection or use of the ST products and services described herein.

No license, express or implied, by estoppel or otherwise, to any intellectual property rights is granted under this document. If any part of this document refers to any third party products or services it shall not be deemed a license grant by ST for the use of such third party products or services, or any intellectual property contained therein or considered as a warranty covering the use in any manner whatsoever of such third party products or services or any intellectual property contained therein.

UNLESS OTHERWISE SET FORTH IN ST'S TERMS AND CONDITIONS OF SALE ST DISCLAIMS ANY EXPRESS OR IMPLIED WARRANTY WITH RESPECT TO THE USE AND/OR SALE OF ST PRODUCTS INCLUDING WITHOUT LIMITATION IMPLIED WARRANTIES OF MERCHANTABILITY, FITNESS FOR A PARTICULAR PURPOSE (AND THEIR EQUIVALENTS UNDER THE LAWS OF ANY JURISDICTION), OR INFRINGEMENT OF ANY PATENT, COPYRIGHT OR OTHER INTELLECTUAL PROPERTY RIGHT.

UNLESS EXPRESSLY APPROVED IN WRITING BY AN AUTHORIZED ST REPRESENTATIVE, ST PRODUCTS ARE NOT RECOMMENDED, AUTHORIZED OR WARRANTED FOR USE IN MILITARY, AIR CRAFT, SPACE, LIFE SAVING, OR LIFE SUSTAINING APPLICATIONS, NOR IN PRODUCTS OR SYSTEMS WHERE FAILURE OR MALFUNCTION MAY RESULT IN PERSONAL INJURY, DEATH, OR SEVERE PROPERTY OR ENVIRONMENTAL DAMAGE. ST PRODUCTS WHICH ARE NOT SPECIFIED AS "AUTOMOTIVE GRADE" MAY ONLY BE USED IN AUTOMOTIVE APPLICATIONS AT USER'S OWN RISK.

Resale of ST products with provisions different from the statements and/or technical features set forth in this document shall immediately void any warranty granted by ST for the ST product or service described herein and shall not create or extend in any manner whatsoever, any liability of ST.

ST and the ST logo are trademarks or registered trademarks of ST in various countries.

Information in this document supersedes and replaces all information previously supplied.

The ST logo is a registered trademark of STMicroelectronics. All other names are the property of their respective owners.

© 2008 STMicroelectronics - All rights reserved

STMicroelectronics group of companies

Australia - Belgium - Brazil - Canada - China - Czech Republic - Finland - France - Germany - Hong Kong - India - Israel - Italy - Japan - Malaysia - Malta - Morocco - Singapore - Spain - Sweden - Switzerland - United Kingdom - United States of America

www.st.com