

GMSM Low Profile Single Row Metal Shell Microminiature Solder Cup and Pre-Wired Connectors

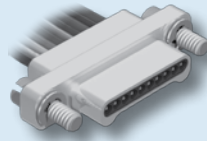

Micro-D
Single Row

HOW TO ORDER GMSM CONNECTORS WITH INSULATED WIRE PIGTAILS



Insulated Wire Pigtails

Series	Shell Finish	Number of Contacts	Contact Type	Wire Gage (AWG)	Wire Type	Wire Color	Wire Length Inches	Hardware	
GMSM	1 – Cadmium	4	P – Pin	4 – #24	K – M22759/11 600 Vrms Teflon (TFE) [®]	1 – White	18 Wire Length In Inches. “.18” Specifies 18 Inches.	B P M M1 S S1 L K F R	
	2 – Nickel	6	S – Socket	6 – #26		J – M22759/33 600 Vrms Modified Cross-Linked Tefzel (ETFE) [®]			2 – Yellow
	4 – Black Anodize	10		8 – #28	5 – Color-Coded Stripes Per MIL-STD-681				
	5 – Gold	15							7 – Ten Color Repeating
	6 – Chem Film	20							
		25							
	Stainless Steel Shell	30			E – NEMA HP3-EB 600 Vrms Type E M16878/4 (TFE) (replaced by M22759/11 for mil spec applications)				
	3 – Passivated	35							
Sample Part Number									
GMSM	2 –	10	P –	6	K	1 –	18	B	

HOW TO ORDER GMSM CONNECTORS WITH UNINSULATED SOLID LEADS

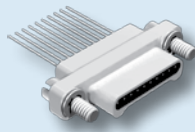

Gold Plated or Solder Dipped Solid Leads

Series	Shell Finish	Number of Contacts	Contact Type	Wire Gage (AWG)	Wire Type	Wire Finish	Wire Length Inches	Hardware
GMSM	1 – Cadmium	4	P – Pin	4 – #24	C – Copper Wire	3 – Solder Dipped (63/37 Tin/Lead)	.125	B P M M1 S S1 L K F R
	2 – Nickel	6	S – Socket	5 – #25			4 – Gold Plated	
	4 – Black Anodize	10		6 – #26		.375		
	5 – Gold	15			.500			
	6 – Chem Film	20			.750			
		25			1.000			
	Stainless Steel Shell	30			2.000			
	3 – Passivated	35			Wire Length In Inches. “.500” Specifies Half Inch.			
Sample Part Number								
GMSM	2 –	10	P –	5	C	4 –	.250	P

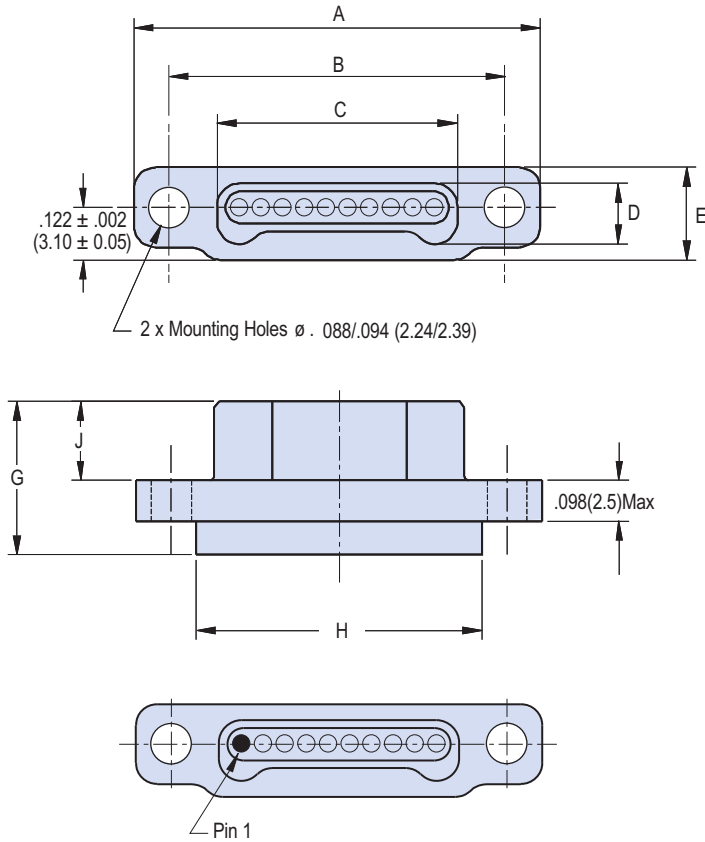

Face View of Pin (Plug) Connector

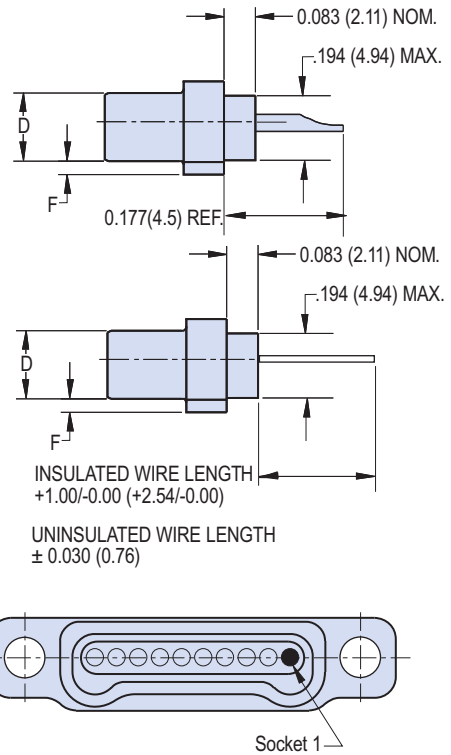

Face View of Socket (Receptacle) Connector

DIMENSIONS

Layout	A Max.		B		C Max.		D Max.		E Max.		F Max.		G Max.		H Max.		J Max.	
	In.	mm.	In. ±.003	mm. ±0.08	In.	mm.	In.	mm.	In.	mm.	In.	mm.	In.	mm.	In.	mm.	In.	mm.
4P	.648	16.45	.478	12.11	.250	6.37	.135	3.42	.218	5.54	.041	1.03	.358	9.10	.309	7.85	.184	4.67
4S	.648	16.45	.478	12.11	.309	7.85	.194	4.94	.218	5.54	.012	0.30	.370	9.40	.309	7.85	.197	5.00
6P	.748	19.00	.578	14.65	.350	8.91	.135	3.42	.218	5.54	.041	1.03	.358	9.10	.409	10.40	.184	4.67
6S	.748	19.00	.578	14.65	.409	10.40	.194	4.94	.218	5.54	.012	0.30	.370	9.40	.409	10.40	.197	5.00
10P	.948	24.07	.777	19.73	.550	13.99	.135	3.42	.218	5.54	.041	1.03	.358	9.10	.609	15.47	.184	4.67
10S	.948	24.07	.777	19.73	.609	15.47	.194	4.94	.218	5.54	.012	0.30	.370	9.40	.609	15.47	.197	5.00
15P	1.198	30.42	1.027	26.08	.800	20.34	.135	3.42	.218	5.54	.041	1.03	.358	9.10	.859	21.82	.184	4.67
15S	1.198	30.42	1.027	26.08	.859	21.82	.194	4.94	.218	5.54	.012	0.30	.370	9.40	.859	21.82	.197	5.00
20P	1.448	36.77	1.277	32.43	1.050	26.69	.135	3.42	.218	5.54	.041	1.03	.358	9.10	1.109	28.17	.184	4.67
20S	1.448	36.77	1.277	32.43	1.109	28.17	.194	4.94	.218	5.54	.012	0.30	.370	9.40	1.109	28.17	.197	5.00
25P	1.698	43.12	1.527	38.78	1.300	33.04	.135	3.42	.218	5.54	.041	1.03	.358	9.10	1.359	34.52	.184	4.67
25S	1.698	43.12	1.527	38.78	1.359	34.52	.194	4.94	.218	5.54	.012	0.30	.370	9.40	1.359	34.52	.197	5.00
30P	1.948	49.47	1.777	45.13	1.550	39.39	.135	3.42	.218	5.54	.041	1.03	.358	9.10	1.609	40.87	.184	4.67
30S	1.948	49.47	1.777	45.13	1.609	40.87	.194	4.94	.218	5.54	.012	0.30	.370	9.40	1.609	40.87	.197	5.00
35P	2.198	55.82	2.027	51.48	1.800	45.74	.135	3.42	.218	5.54	.041	1.03	.358	9.10	1.859	47.22	.184	4.67
35S	2.198	55.82	2.027	51.48	1.859	47.22	.194	4.94	.218	5.54	.012	0.30	.370	9.40	1.859	47.22	.197	5.00