



V A N T I S
AN AMD COMPANY

MACH[®] 5 Family

Fifth Generation MACH Architecture

DISTINCTIVE CHARACTERISTICS

- ◆ **Fifth generation MACH architecture**
 - 100% routable
 - Pin-out retention
 - Four power/speed options per block for maximum performance and lowest power
 - Synchronous and asynchronous clocking, including dual-edge clocking
 - Asynchronous product- or sum-term reset
 - Functions of up to 32 product terms
 - Fixed, predictable delays
- ◆ **High speed**
 - 7.5 ns t_{PD} Commercial, 10 ns t_{PD} Industrial
 - 125 MHz f_{CNT}
- ◆ **High densities**
 - 128 to 512 macrocells
 - 16 to 64 output enables
 - Multiple density options for each package
- ◆ **System performance capabilities**
 - Both 5-V and JEDEC-compliant 3.3-V versions
 - In-system programmable
 - JTAG (IEEE 1149.1) boundary scan testing
 - PCI compliance (-7/-10/-12 speed grades)
 - Safe for mixed supply voltage system design
 - Bus-Friendly™ I/Os
 - Individual output slew rate control
 - Programmable security bit
- ◆ **Leading-edge process technology**
 - 0.35 and 0.5 micron (L_{eff}) processes
- ◆ **Supported by Vantis MACHXL[®] software**
 - Design entry ports to universal tools
 - Low-cost entry-level tool
 - Windows GUI interface
 - Auto device selection
 - Multiple device partitioning
- ◆ **Extensive software development support**
- ◆ **Third-party hardware programming support**

MACH5 Family



PRODUCT SELECTOR GUIDE

Device	Macrocells	I/O Options	Speeds (t _{PD})	Packages
M5-128 M5LV-128	128	68, 104, 120	7, 10, 12, 15 COM 10, 12, 15, 20 IND	PQFP, TQFP
M5-192 M5LV-192	192	68, 104, 120, 160	7, 10, 12, 15 COM 10, 12, 15, 20 IND	PQFP, TQFP
M5-256 M5LV-256	256	68, 104, 120, 160	7, 10, 12, 15 COM 10, 12, 15, 20 IND	PQFP, TQFP
M5-320 M5LV-320	320	120, 160, 184, 192	7, 10, 12, 15 COM 10, 12, 15, 20 IND	PQFP, BGA
M5-384 M5LV-384	384	120, 160, 184, 192	7, 10, 12, 15 COM 10, 12, 15, 20 IND	PQFP, BGA
M5-512 M5LV-512	512	120, 160, 184, 192, 256	7, 10, 12, 15 COM 10, 12, 15, 20 IND	PQFP, BGA

GENERAL DESCRIPTION

The MACH 5 family consists of a broad range of high-density, high-performance, and low-power complex programmable logic devices (CPLDs) with features such as in-system programmability, JTAG testability, and advanced clocking options. These fifth-generation MACH devices have advanced power management options which allow designers to incrementally reduce power. Both the 3.3-V and 5-V device versions are safe for mixed-voltage design, and the 7.5-, 10-, and 12-ns devices are compliant with the *PCI Local Bus Specification*. The MACH 5 family is manufactured in AMD's state-of-the-art ISO 9000 qualified fabrication facilities on 0.5- and 0.35- micron I_{eff} EECMOS process technology.

All devices are available with pin-to-pin delays as fast as 7.5 ns and possess the density required for full system logic integration. The largest device, the M5-512, has 512 macrocells. The MACH 5 family's unique hierarchical architecture is ideal for PAL[®] device integration and a wide range of other applications including high-speed computing, low-power applications, communications, and embedded control.

Vantis offers software design support for MACH devices through its own development system and device fitters integrated into third-party CAE tools. Platform support extends across PCs, Sun and HP workstations under advanced operating systems such as Windows 3.1, Windows 95 and NT, SunOS and Solaris, and HPUX.

MACHXL software is a complete development system for the PC, supporting Vantis' MACH devices. It supports design entry with Boolean and behavioral syntax, state machine syntax and truth tables. Functional simulation and static timing analysis are also included in this easy-to-use system. This development system includes high-performance device fitters for all MACH devices.

The same fitter technology included in MACHXL software is seamlessly incorporated into third-party tools from leading CAE vendors such as Synario, Viewlogic, Mentor Graphics, Cadence and MINC. Interface kits and MACHXL configurations are also available to support design entry and verification with other leading vendors such as Synopsys, Exemplar, OrCAD, Synplicity and Model Technology. These MACHXL configurations and interfaces accept EDIF 2.0.0 netlists, generate JEDEC files for MACH devices, and create industry-standard SDF, VITAL-compliant VHDL and Verilog output files for design simulation.

Vantis offers in-system programming support for MACH devices through its MACHPRO[®] software enabling MACH device programmability through JTAG compliant ports and easy-to-use PC interface. Additionally, MACHPRO generated vectors work seamlessly with HP3070, GenRad and Teradyne testers to program MACH devices or test them for connectivity.

All MACH devices are supported by industry standard programmers available from a number of vendors. These programmer vendors include Advin Systems, BP Microsystems, Data I/O Corporation, Hi-Lo Systems, SMS GmbH, Stag House, and System General.

Table 1. MACH Device Features

Feature	M5-128 M5LV-128	M5-192 M5LV-192	M5-256 M5LV-256	M5-320 M5LV-320	M5-384 M5LV-384	M5-512 M5LV-512
PLD Gates	5000	7500	10000	12000	15000	20000
Macrocells	128	192	256	320	384	512
Maximum I/O	120	160	160	192	192	256
Power (mA)	35	45	55	70	75	100
t _{PD} (ns)	7.5	7.5	7.5	7.5	7.5	7.5
t _{SS} (ns)	4	4	4	4	4	4
t _{COS} (ns)	6	6	6	6	6	6
f _{CNT} (MHz)	125	125	125	125	125	125
JTAG Compliant	Yes	Yes	Yes	Yes	Yes	Yes
PCI Compliant	-7/-10/-12	-7/-10/-12	-7/-10/-12	-7/-10/-12	-7/-10/-12	-7/-10/-12

Table 2. Package and Device Options

Package	M5-128 M5LV-128	M5-192 M5LV-192	M5-256 M5LV-256	M5-320 M5LV-320	M5-384 M5LV-384	M5-512 M5LV-512
100 PQFP (68 I/O)	X	X	X			
100 TQFP (68 I/O)	X	X	X			
144 PQFP (104 I/O)	X	X	X			
160 PQFP (120 I/O)	X	X	X	X	X	X
208 PQFP (160 I/O)		X	X	X	X	X
240 PQFP (184 I/O)				X	X	X
256 BGA (192 I/O)				X	X	X
352 BGA (256 I/O)						X

CONNECTION DIAGRAM

Top View

100-Pin PQFP

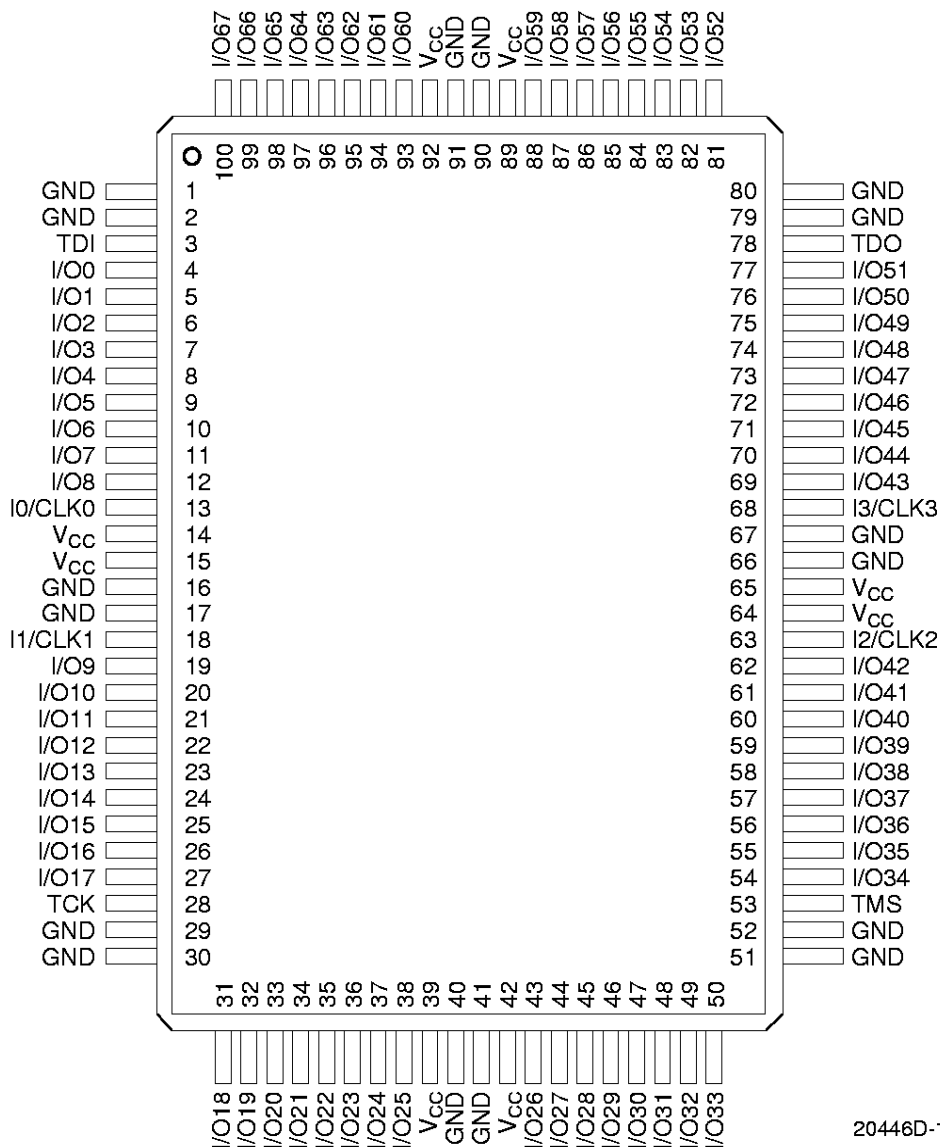

20446D-1

M5-128/68, M5LV-128/68
 M5-192/68, M5LV-192/68
 M5-256/68, M5LV-256/68

PIN DESIGNATIONS

CLK	=	Clock	TDI	=	Test Data In
GND	=	Ground	TCK	=	Test Clock
I	=	Input	TMS	=	Test Mode Select
I/O	=	Input/Output	TDO	=	Test Data Out
NC	=	No Connect			
V _{CC}	=	Supply Voltage			

MACH5 Family

CONNECTION DIAGRAM

Top View

100-Pin TQFP

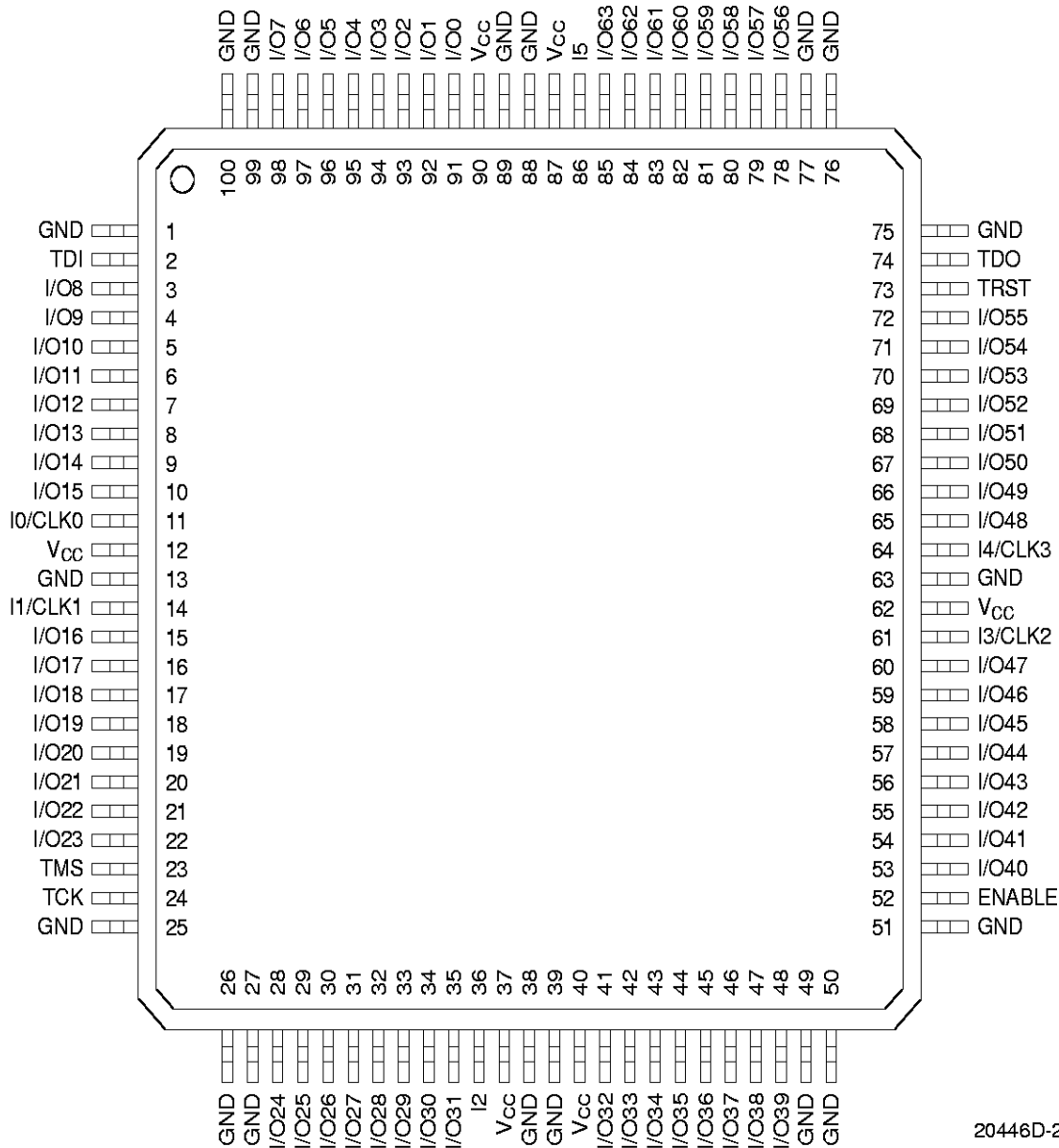

20446D-2

M5-128/68, M5LV-128/68
M5-192/68, M5LV-192/68
M5-256/68, M5LV-256/68

CONNECTION DIAGRAM

Top View

144-Pin PQFP

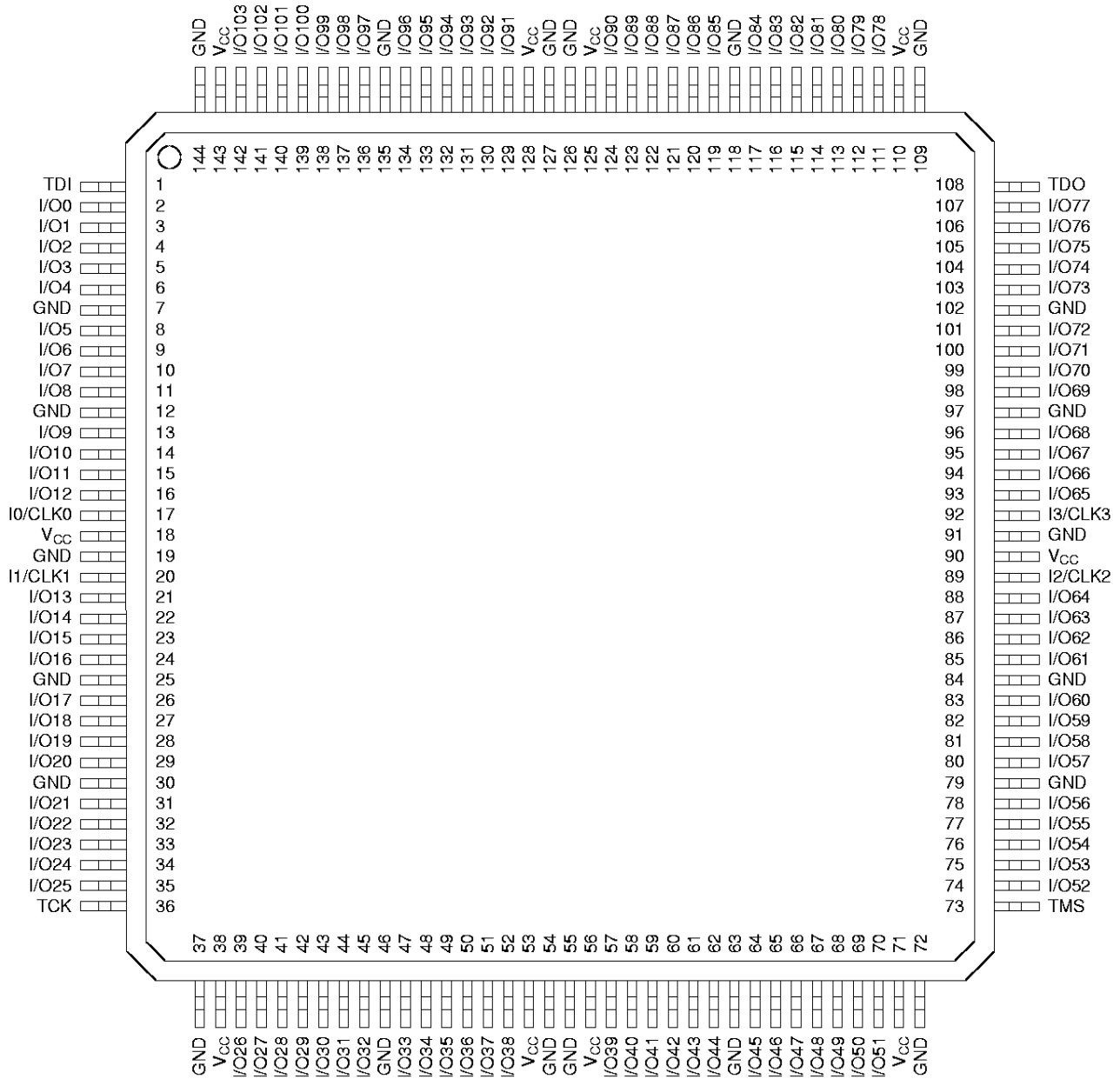

MACH5 Family

20446D-3

M5-128/104, M5LV-128/104

M5-192/104, M5LV-192/104

M5-256/104, M5LV-256/104

CONNECTION DIAGRAM

Top View

160-Pin PQFP

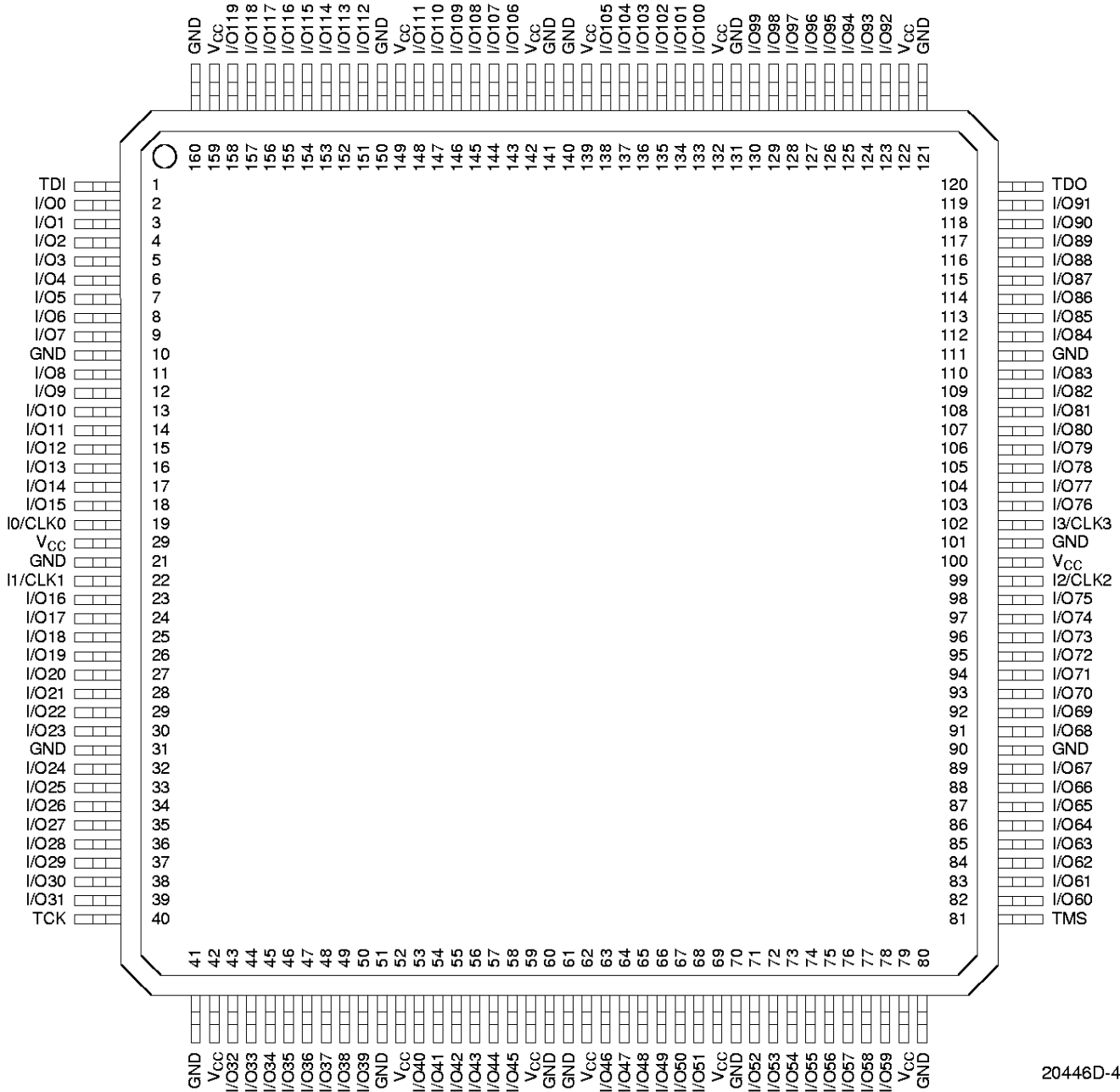

20446D-4

- M5-128/120, M5LV-128/120
- M5-192/120, M5LV-192/120
- M5-256/120, M5LV-256/120
- M5-320/120, M5LV-320/120
- M5-384/120, M5LV-384/120
- M5-512/120, M5LV-512/120

CONNECTION DIAGRAM

Top View

208-Pin PQFP

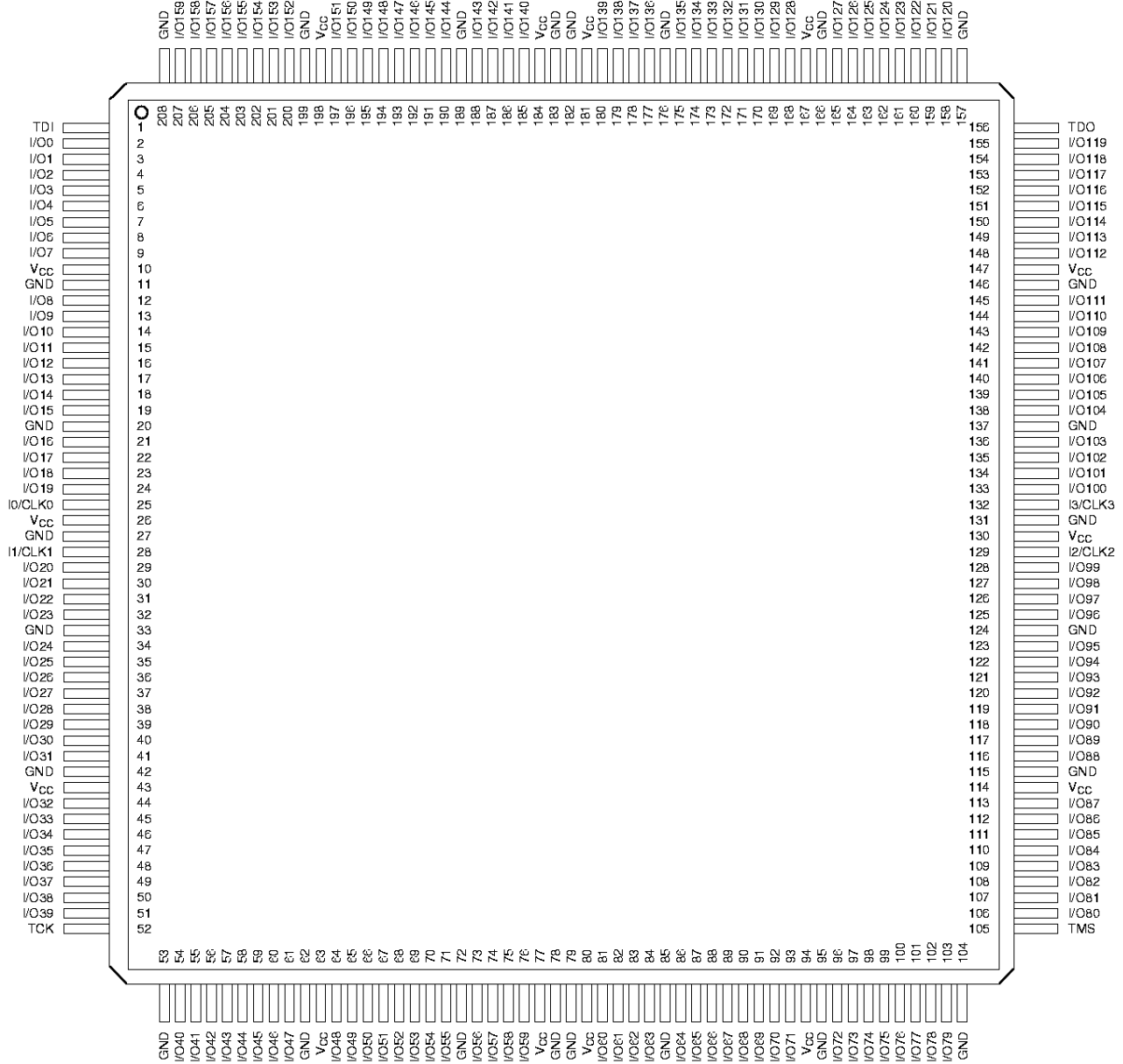

20446D-5

M5-192/160, M5LV-192/160

M5-256/160, M5LV-256/160

M5-320/160, M5LV-320/160

M5-384/160, M5LV-384/160

M5-512/160, M5LV-512/160

CONNECTION DIAGRAM

Top View

240-Pin PQFP

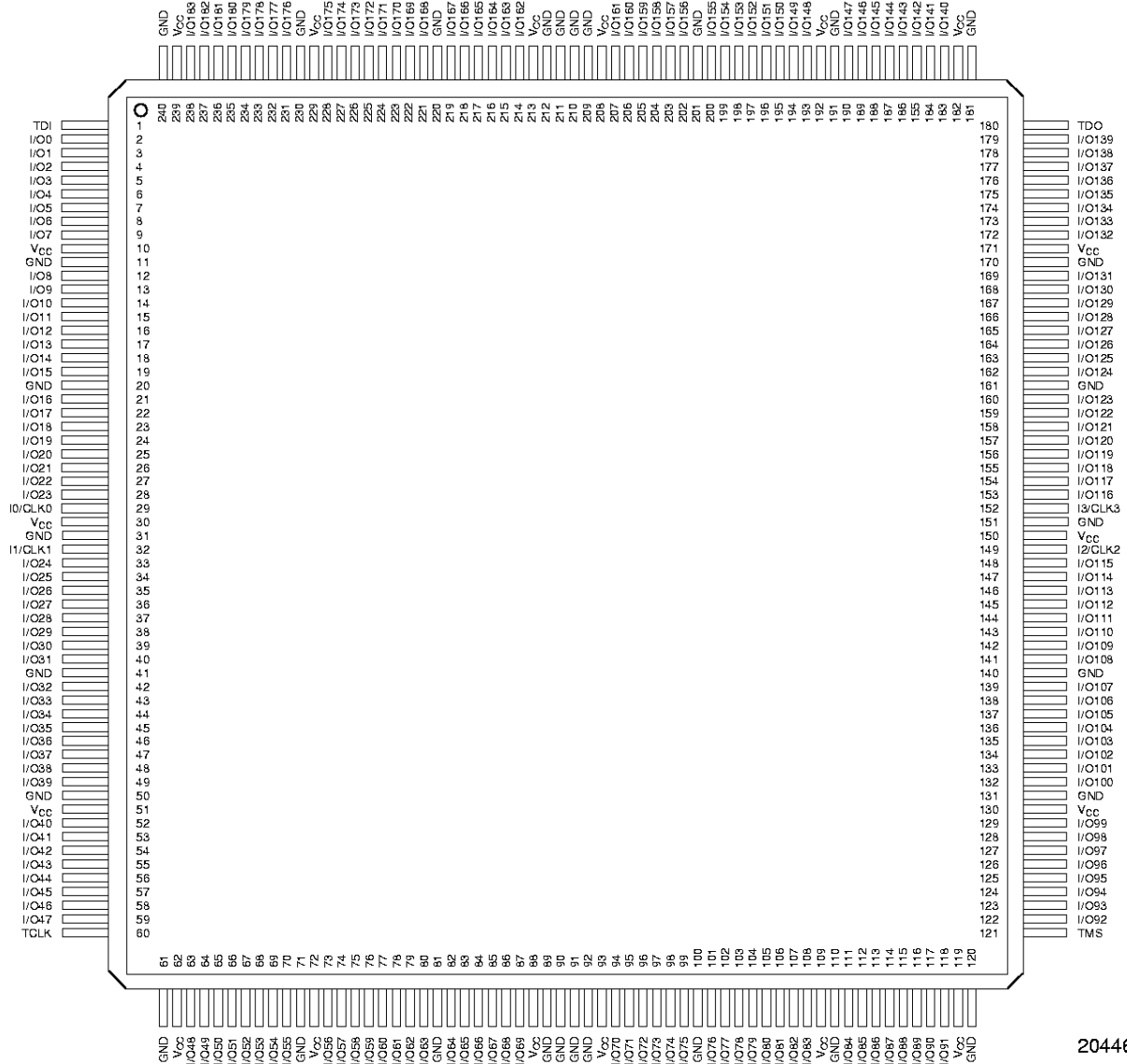

20446D-6

M5-320/184, M5LV-320/184
M5-384/184, M5LV-384/184
M5-512/184, M5LV-512/184

CONNECTION DIAGRAM

Bottom View

256-Pin BGA

	A	B	C	D	E	F	G	H	J	K	L	M	N	P	R	T	U	V	W	Y
1	GND	GND	GND	GND	GND	GND	GND	GND	GND	GND	GND	GND	GND	GND	GND	GND	GND	GND	GND	GND
2	GND	GND	GND	GND	GND	GND	GND	GND	GND	GND	GND	GND	GND	GND	GND	GND	GND	GND	GND	GND
3	GND	GND	GND	GND	GND	GND	GND	GND	GND	GND	GND	GND	GND	GND	GND	GND	GND	GND	GND	GND
4	GND	GND	GND	GND	GND	GND	GND	GND	GND	GND	GND	GND	GND	GND	GND	GND	GND	GND	GND	GND
5	GND	GND	GND	GND	GND	GND	GND	GND	GND	GND	GND	GND	GND	GND	GND	GND	GND	GND	GND	GND
6	GND	GND	GND	GND	GND	GND	GND	GND	GND	GND	GND	GND	GND	GND	GND	GND	GND	GND	GND	GND
7	GND	GND	GND	GND	GND	GND	GND	GND	GND	GND	GND	GND	GND	GND	GND	GND	GND	GND	GND	GND
8	GND	GND	GND	GND	GND	GND	GND	GND	GND	GND	GND	GND	GND	GND	GND	GND	GND	GND	GND	GND
9	GND	GND	GND	GND	GND	GND	GND	GND	GND	GND	GND	GND	GND	GND	GND	GND	GND	GND	GND	GND
10	GND	GND	GND	GND	GND	GND	GND	GND	GND	GND	GND	GND	GND	GND	GND	GND	GND	GND	GND	GND
11	GND	GND	GND	GND	GND	GND	GND	GND	GND	GND	GND	GND	GND	GND	GND	GND	GND	GND	GND	GND
12	GND	GND	GND	GND	GND	GND	GND	GND	GND	GND	GND	GND	GND	GND	GND	GND	GND	GND	GND	GND
13	GND	GND	GND	GND	GND	GND	GND	GND	GND	GND	GND	GND	GND	GND	GND	GND	GND	GND	GND	GND
14	GND	GND	GND	GND	GND	GND	GND	GND	GND	GND	GND	GND	GND	GND	GND	GND	GND	GND	GND	GND
15	GND	GND	GND	GND	GND	GND	GND	GND	GND	GND	GND	GND	GND	GND	GND	GND	GND	GND	GND	GND
16	GND	GND	GND	GND	GND	GND	GND	GND	GND	GND	GND	GND	GND	GND	GND	GND	GND	GND	GND	GND
17	GND	GND	GND	GND	GND	GND	GND	GND	GND	GND	GND	GND	GND	GND	GND	GND	GND	GND	GND	GND
18	GND	GND	GND	GND	GND	GND	GND	GND	GND	GND	GND	GND	GND	GND	GND	GND	GND	GND	GND	GND
19	GND	GND	GND	GND	GND	GND	GND	GND	GND	GND	GND	GND	GND	GND	GND	GND	GND	GND	GND	GND
20	GND	GND	GND	GND	GND	GND	GND	GND	GND	GND	GND	GND	GND	GND	GND	GND	GND	GND	GND	GND

20446D-7

M5-320/192, M5LV-320/192
 M5-384/192, M5LV-384/192
 M5-512/192, M5LV-512/192



CONNECTION DIAGRAM

Bottom View

352-Pin BGA

	A	B	C	D	E	F	G	H	J	K	L	M	N	P	R	T	U	V	W	Y	AA	AB	AC	AD	AE	AF
1	NC	NC	NC	GND	NC	I/O245	GND	I/O246	I/O247	GND	I/O248	I/O249	I/O250	I/O251	I/O252	GND	GND	I/O253	I/O254	GND	NC	I/O255	GND	NC	NC	
2	NC	NC	NC	I/O224	I/O225	I/O226	I/O227	I/O228	I/O229	I/O230	I/O231	I/O232	I/O233	I/O234	I/O235	I/O236	I/O237	I/O238	I/O239	I/O240	I/O241	I/O242	I/O243	I/O244	NC	NC
3	GND	GND	NC	I/O205	I/O206	I/O207	I/O208	I/O209	I/O210	I/O211	I/O212	I/O213	I/O214	I/O215	I/O216	I/O217	I/O218	I/O219	I/O220	I/O221	I/O222	I/O223	TMS	NC	NC	NC
4	NC	I/O188	NC	TDO	I/O189	I/O190	I/O191	V _{cc}	I/O192	V _{cc}	I/O193	I/O194	I/O195	V _{cc}	I/O196	I/O197	I/O198	V _{cc}	I/O199	V _{cc}	I/O200	I/O201	V _{cc}	I/O202	I/O203	I/O204
5	GND	I/O183	I/O184	V _{cc}																		I/O185	I/O186	I/O187	GND	
6	NC	I/O176	I/O177	I/O178																		I/O179	I/O180	I/O181	I/O182	
7	GND	I/O169	I/O170	I/O171																		I/O172	I/O173	I/O174	I/O175	
8	I/O162	I/O163	I/O164	I/O165																		I/O166	I/O167	I/O168	NC	
9	I/O156	I/O157	I/O158	I/O159																		V _{cc}	I/O160	I/O161	I/O162	
10	GND	I/O150	I/O151	V _{cc}																		I/O152	I/O153	I/O154	I/O155	
11	I/O142	I/O143	I/O144	I/O145																		I/O146	I/O147	I/O148	I/O149	
12	I/O134	I/O135	I/O136	I/O137																		I/O138	I/O139	I/O140	I/O141	
13	I/O128	I/O129	I/O130	I/O131																		V _{cc}	I/O132	I/O133	I/O134	
14	GND	I/O122	I/O123	V _{cc}																		I/O124	I/O125	I/O126	I/O127	
15	I/O114	I/O115	I/O116	I/O117																		I/O118	I/O119	I/O120	I/O121	
16	NC	I/O107	I/O108	I/O109																		I/O110	I/O111	I/O112	I/O113	
17	I/O101	I/O102	I/O103	I/O104																		V _{cc}	I/O105	I/O106	I/O107	
18	GND	I/O95	I/O96	V _{cc}																		I/O97	I/O98	I/O99	I/O100	
19	I/O87	I/O88	I/O89	I/O90																		I/O81	I/O82	I/O83	I/O84	
20	I/O80	I/O81	I/O82	I/O83																		I/O84	I/O85	I/O86	I/O87	
21	I/O73	I/O74	I/O75	I/O76																		I/O77	I/O78	I/O79	NC	
22	GND	I/O68	I/O69	I/O70																		V _{cc}	I/O71	I/O72	GND	
23	I/O51	I/O52	I/O53	V _{cc}																		I/O50	TKC	I/O51	I/O52	
24	NC	NC	TDI	I/O32	I/O33	I/O34	I/O35	I/O36	I/O37	I/O38	I/O39	I/O40	V _{cc}	I/O41	I/O42	I/O43	I/O44	I/O45	I/O46	I/O47	I/O48	I/O49	NC	NC	NC	
25	GND	GND	I/O11	I/O12	I/O13	I/O14	I/O15	I/O16	I/O17	I/O18	I/O19	I/O20	I/O21	I/O22	I/O23	I/O24	I/O25	I/O26	I/O27	I/O28	I/O29	I/O30	NC	NC	NC	
26	NC	NC	I/O11	I/O12	I/O13	I/O14	I/O15	I/O16	I/O17	I/O18	I/O19	I/O20	I/O21	I/O22	I/O23	I/O24	I/O25	I/O26	I/O27	I/O28	I/O29	I/O30	NC	NC	NC	

ORDERING INFORMATION

MACH 5 COM -7.5, -10, -12, -15

Vantis standard products are available in several packages and operating ranges. The order number (Valid Combination) is formed by a combination of the elements below.

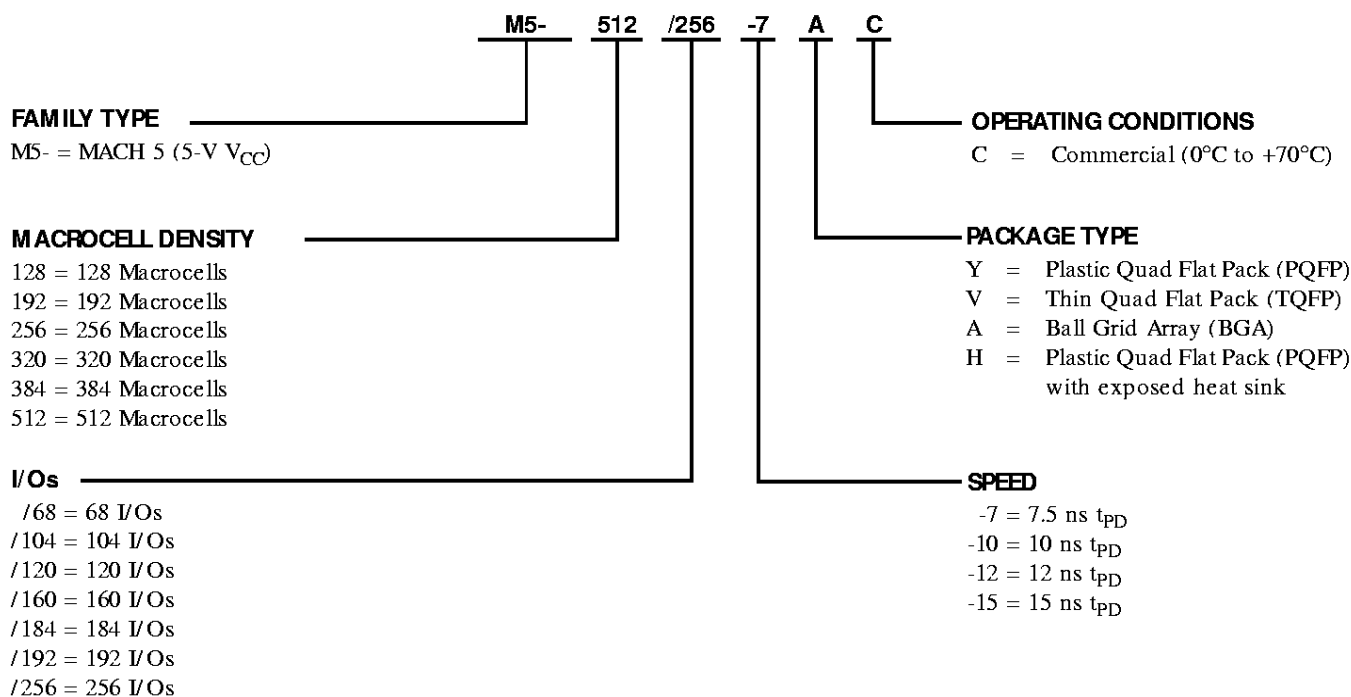

Valid Combinations		
M5-128/68	-7, -10, -12, -15	YC, VC
M5-128/104		YC
M5-128/120		YC
M5-192/68		YC, VC
M5-192/104		YC
M5-192/120		YC
M5-192/160		YC
M5-256/68		YC, VC
M5-256/104		YC
M5-256/120		YC
M5-256/160		YC

Device Marking

Actual device marking differs from the ordering part number (OPN). "MACH 5" is marked on a device wherever "M5-" is used in the OPN.

Valid Combinations		
M5-320/120	-7, -10, -12, -15	HC
M5-320/160		HC
M5-320/184		HC
M5-320/192		AC
M5-384/120		HC
M5-384/160		HC
M5-384/184		HC
M5-384/192		AC
M5-512/120		HC
M5-512/160		HC
M5-512/184		HC
M5-512/192		AC
M5-512/256		AC

Valid Combinations

Valid Combinations list configurations planned to be supported in volume for this device. Consult the local Vantis sales office to confirm availability of specific valid combinations and to check on newly released combinations.

Mach 5 Family

ORDERING INFORMATION

MACH 5 LV COM -7.5, -10, -12, -15

Vantis standard products are available in several packages and operating ranges. The order number (Valid Combination) is formed by a combination of the elements below.

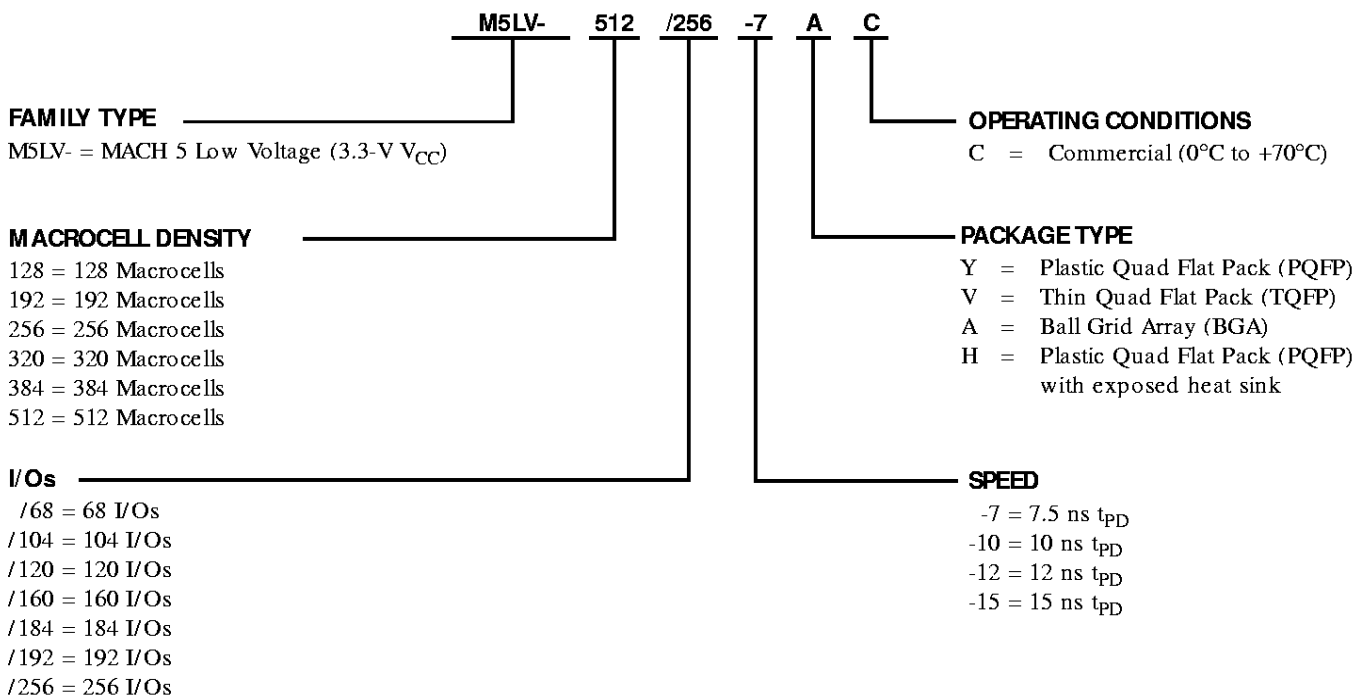

Valid Combinations		
M5LV-128/68	-7, -10, -12, -15	YC, VC
M5LV-128/104		YC
M5LV-128/120		YC
M5LV-192/68		YC, VC
M5LV-192/104		YC
M5LV-192/120		YC
M5LV-192/160		YC
M5LV-256/68		YC, VC
M5LV-256/104		YC
M5LV-256/120		YC
M5LV-256/160		YC

Device Marking

Actual device marking differs from the ordering part number (OPN). "MACH 5" is marked on a device wherever "M5-" is used in the OPN.

Valid Combinations		
M5LV-320/120	-7, -10, -12, -15	HC
M5LV-320/160		HC
M5LV-320/184		HC
M5LV-320/192		AC
M5LV-384/120		HC
M5LV-384/160		HC
M5LV-384/184		AC
M5LV-384/192		HC
M5LV-512/120		HC
M5LV-512/160		HC
M5LV-512/184		HC
M5LV-512/192		AC
M5LV-512/256	AC	

Valid Combinations

Valid Combinations list configurations planned to be supported in volume for this device. Consult the local Vantis sales office to confirm availability of specific valid combinations and to check on newly released combinations.

ORDERING INFORMATION

MACH 5 IND -10, -12, -15, -20

Vantis standard products are available in several packages and operating ranges. The order number (Valid Combination) is formed by a combination of the elements below.

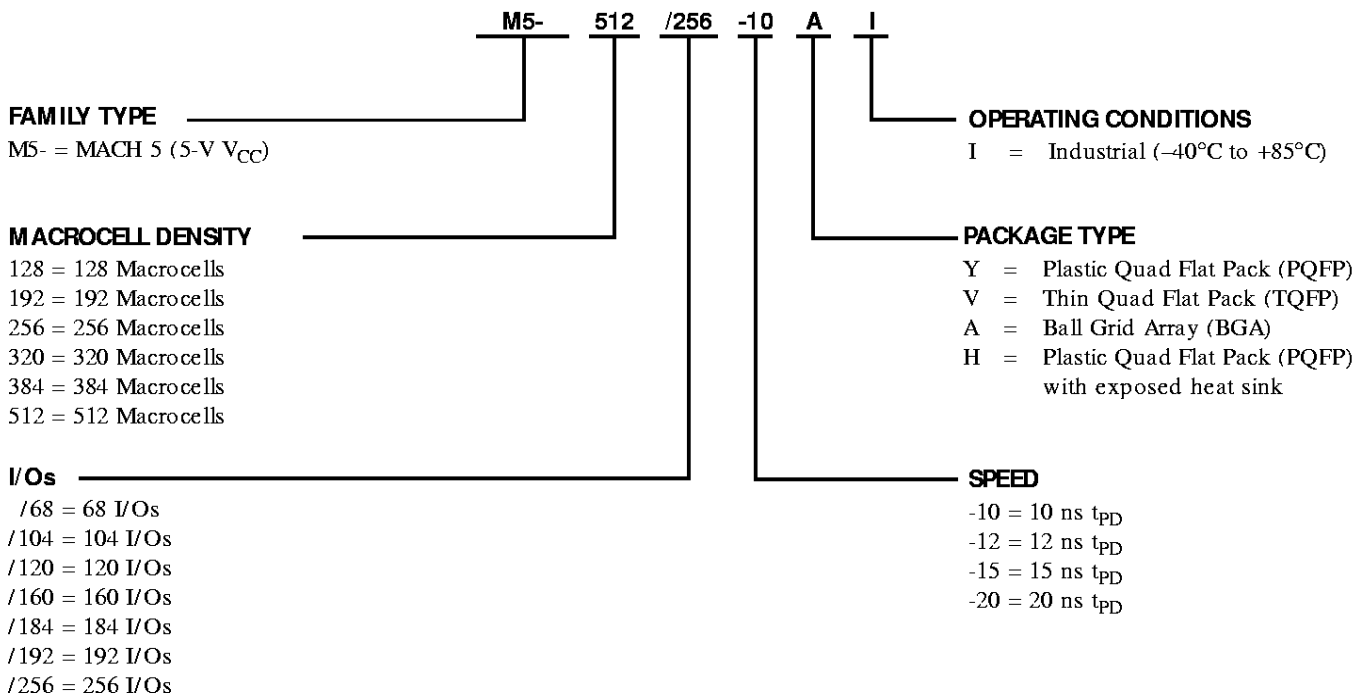

Valid Combinations		
M5-128/68	-10, -12, -15, -20	YI, VI
M5-128/104		YI
M5-128/120		YI
M5-192/68		YI, VI
M5-192/104		YI
M5-192/120		YI
M5-192/160		YI
M5-256/68		YI, VI
M5-256/104		YI
M5-256/120		YI
M5-256/160		YI

Device Marking

Actual device marking differs from the ordering part number (OPN). "MACH 5" is marked on a device wherever "M5-" is used in the OPN.

Valid Combinations		
M5-320/120	-10, -12, -15, -20	HI
M5-320/160		HI
M5-320/184		HI
M5-320/192		AI
M5-384/120		HI
M5-384/160		HI
M5-384/184		HI
M5-384/192		AI
M5-512/120		HI
M5-512/160		HI
M5-512/184		HI
M5-512/192		AI
M5-512/256		AI

Valid Combinations

Valid Combinations list configurations planned to be supported in volume for this device. Consult the local Vantis sales office to confirm availability of specific valid combinations and to check on newly released combinations.

Mach 5 Family

ORDERING INFORMATION

MACH 5 LV IND -10, -12, -15, -20

Vantis standard products are available in several packages and operating ranges. The order number (Valid Combination) is formed by a combination of the elements below.

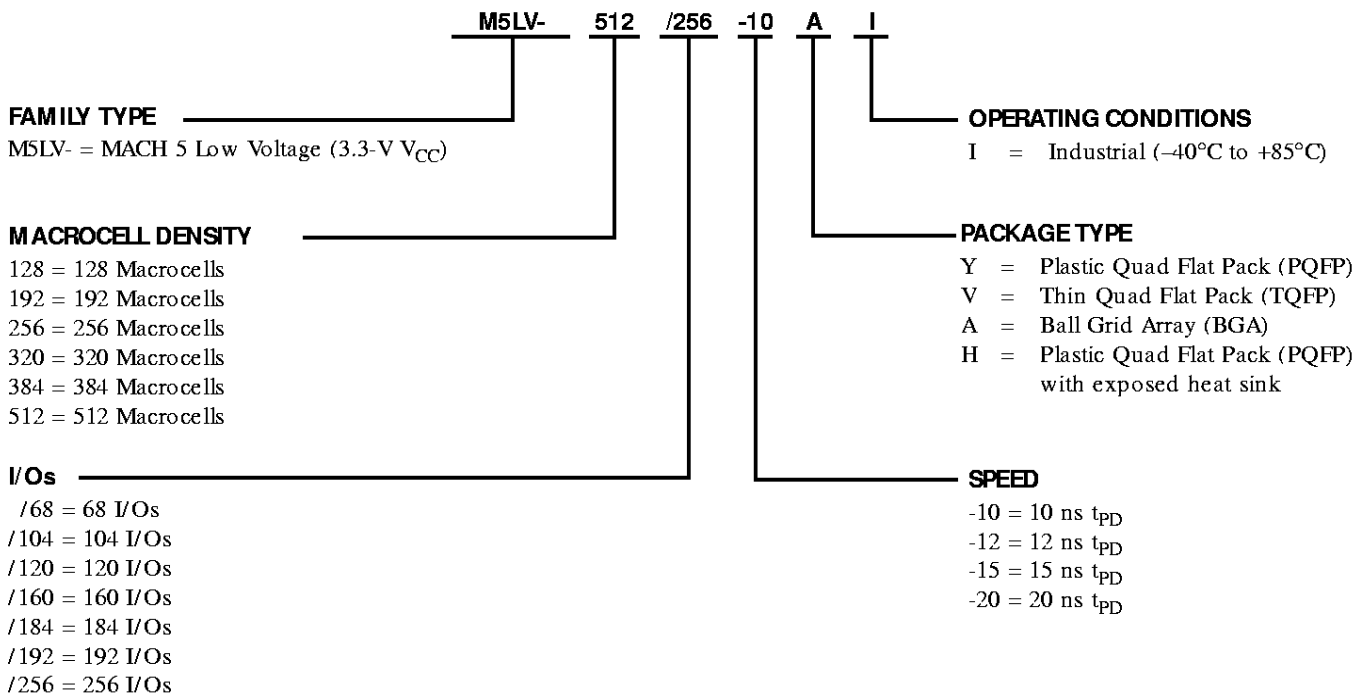

Valid Combinations		
M5LV-128/68	-10, -12, -15, -20	YI, VI
M5LV-128/104		YI
M5LV-128/120		YI
M5LV-192/68		YI, VI
M5LV-192/104		YI
M5LV-192/120		YI
M5LV-192/160		YI
M5LV-256/68		YI, VI
M5LV-256/104		YI
M5LV-256/120		YI
M5LV-256/160		YI

Device Marking

Actual device marking differs from the ordering part number (OPN). "MACH 5" is marked on a device wherever "M5-" is used in the OPN.

Valid Combinations		
M5LV-320/120	-10, -12, -15, -20	HI
M5LV-320/160		HI
M5LV-320/184		HI
M5LV-320/192		AI
M5LV-384/120		HI
M5LV-384/160		HI
M5LV-384/184		HI
M5LV-384/192		AI
M5LV-512/120		HI
M5LV-512/160		HI
M5LV-512/184		HI
M5LV-512/192		AI
M5LV-512/256		AI

Valid Combinations

Valid Combinations list configurations planned to be supported in volume for this device. Consult the local Vantis sales office to confirm availability of specific valid combinations and to check on newly released combinations.

FUNCTIONAL DESCRIPTION

The Fifth Generation MACH Architecture yields the highest speeds at the highest CPLD densities. Extensive routing resources ensure pinout retention as well as high utilization. The MACH 5 architecture consists of PAL blocks connected by two levels of interconnect. Each group of four PAL blocks is given its own routing resources, called **block interconnect**. Together, the four PAL blocks and their block interconnect are called a **segment**. The second level of interconnect, the **segment interconnect**, ties all of the segments together (see Figure 1). The only logic difference between any two MACH 5 devices is the number of segments, so once a designer is familiar with one device, consistent performance can be expected across the entire family. All devices have four pin clocks available which can also be used as logic inputs.

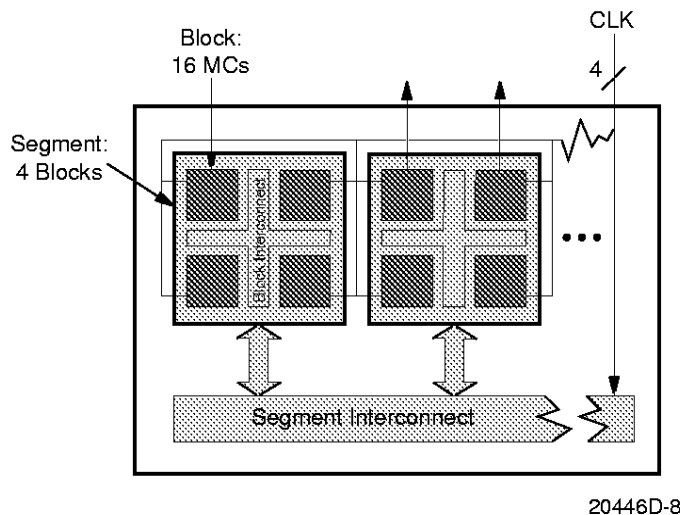

Figure 1. MACH 5 Block Diagram with Segment Numbers

Enhanced PAL Block

The MACH 5 PAL blocks consist of the elements listed below. While each PAL block resembles an independent PAL device, it has superior control and logic generation capabilities.

- ◆ Macrocell
- ◆ Logic array
- ◆ Logic allocator
- ◆ I/O cell
- ◆ Register control generator
- ◆ Output enable generator

The I/Os associated with each PAL block (Figure 2) have a path directly back to that PAL block called **local feedback**. If the I/O is used in another PAL block, the **interconnect feeder** assigns a **block interconnect** line to that signal. The interconnect feeder acts as an input switch matrix. The block and segment interconnect provide connections between any two signals in a device. The **block feeder** assigns block interconnect lines and local feedback lines to the PAL block inputs. Two inputs per PAL block can also be fed directly to a macrocell for registered input applications.

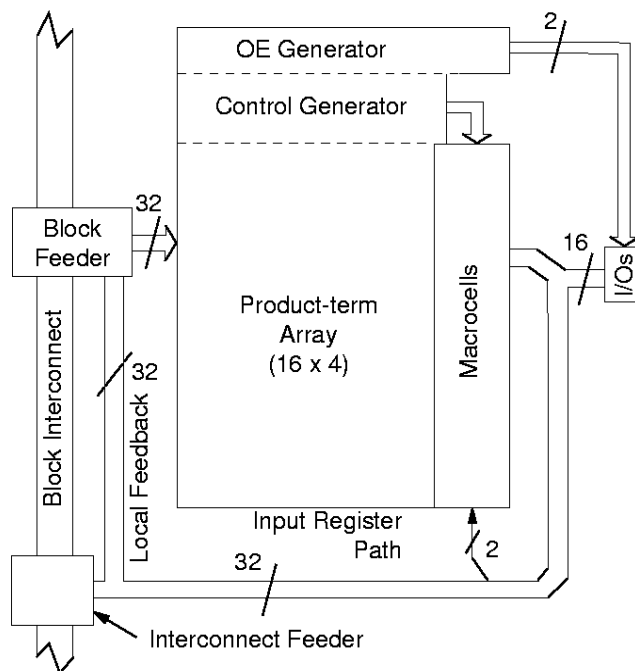

20446D-9

Figure 2. PAL Block Structure

Logic Array and Allocator

The product-term array has the familiar sum-of-products architecture used in PAL devices. The logic allocator assigns product terms to macrocells. Up to eight clusters of four product terms can be steered to one macrocell, and product terms can be steered in a basic cluster of three or four product terms. If three product terms are steered away, one can be left for separate logic generation. The logic allocator acts as an output logic switch matrix: as a design changes, the **logic allocator** will reassign logic to macrocells to retain pinout. If not used in a cluster, the extra product term can be XORed with the basic cluster for functions such as data comparison. If the basic cluster of three product terms is steered away, the product term remaining can still be used for logic generation. The XOR gate available to each macrocell can be used for logic and/or for polarity control. The product term clusters available to each macrocell within a PAL block are shown in Table 3.

Rather than an output switch matrix which reassigns macrocells to pins to retain pinout, the wide logic allocator produces the same result by reassigning logic to macrocells. In addition, large equations (up to 32 product terms) can be implemented in a MACH 5 device with only one pass through the logic array.

Table 3. Product Term Steering Options for PT Clusters and Macrocells

Macrocell	Available Clusters	Macrocell	Available Clusters
M ₀	C ₀ , C ₁ , C ₂ , C ₃ , C ₄	M ₈	C ₅ , C ₆ , C ₇ , C ₈ , C ₉ , C ₁₀ , C ₁₁ , C ₁₂
M ₁	C ₀ , C ₁ , C ₂ , C ₃ , C ₄ , C ₅	M ₉	C ₆ , C ₇ , C ₈ , C ₉ , C ₁₀ , C ₁₁ , C ₁₂ , C ₁₃
M ₂	C ₀ , C ₁ , C ₂ , C ₃ , C ₄ , C ₅ , C ₆	M ₁₀	C ₇ , C ₈ , C ₉ , C ₁₀ , C ₁₁ , C ₁₂ , C ₁₃ , C ₁₄
M ₃	C ₀ , C ₁ , C ₂ , C ₃ , C ₄ , C ₅ , C ₆ , C ₇	M ₁₁	C ₈ , C ₉ , C ₁₀ , C ₁₁ , C ₁₂ , C ₁₃ , C ₁₄ , C ₁₅
M ₄	C ₀ , C ₁ , C ₂ , C ₃ , C ₄ , C ₅ , C ₆ , C ₇	M ₁₂	C ₈ , C ₉ , C ₁₀ , C ₁₁ , C ₁₂ , C ₁₃ , C ₁₄ , C ₁₅
M ₅	C ₁ , C ₂ , C ₃ , C ₄ , C ₅ , C ₆ , C ₇ , C ₈	M ₁₃	C ₉ , C ₁₀ , C ₁₁ , C ₁₂ , C ₁₃ , C ₁₄ , C ₁₅
M ₆	C ₂ , C ₃ , C ₄ , C ₅ , C ₆ , C ₇ , C ₈ , C ₉	M ₁₄	C ₁₀ , C ₁₁ , C ₁₂ , C ₁₃ , C ₁₄ , C ₁₅
M ₇	C ₃ , C ₄ , C ₅ , C ₆ , C ₇ , C ₈ , C ₉ , C ₁₀	M ₁₅	C ₁₁ , C ₁₂ , C ₁₃ , C ₁₄ , C ₁₅

Macrocells

The macrocells for MACH 5 consist of a storage element, a control (clock and set or reset or latch enable) bus, and routing resources. The macrocell (Figure 3) can be configured for combinatorial, registered or latched operation. The D-type flip-flops can be configured as T-type, J-K, or S-R operation through the use of the XOR gate associated with each macrocell.

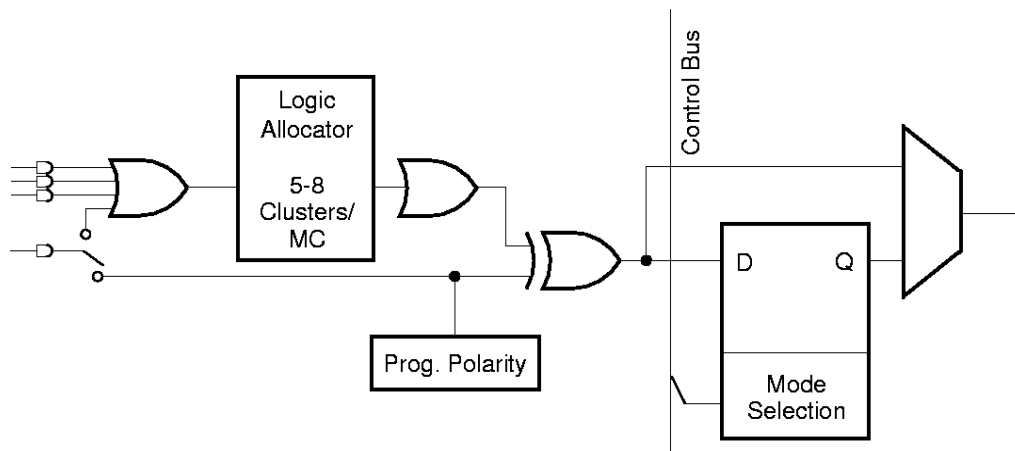

Figure 3. Macrocell Diagram

20446D-10

Control Generator

The control generator provides four configurable clock lines and three configurable set/reset lines to each macrocell in a PAL block. Any of the four clock lines and any of the three set/reset lines can be independently selected by any flip-flop within a block. The clock lines (Figure 4) provide synchronous global (pin) clocks and asynchronous product term clocks, sum term clocks, and latch enables. Positive or negative edge clocking is available as well as advanced clocking features such as **complementary** and **biphase** clocking. Complementary clocking provides two clock lines exactly 180 degrees out of phase, and is useful in applications such as fast data paths. A biphase clock line clocks flip-flops on both the positive and negative edges of the clock. The configuration options for the four clock lines per PAL block are as follows:

Clock Line 0 Options

- ◆ Global clock (0, 1, 2, or 3) with positive or negative edge clock enable
- ◆ Product-term clock ($A*B*C$)
- ◆ Sum-term clock ($A+B+C$)

Clock Line 1 Options

- ◆ Global clock (0, 1, 2, or 3) with positive edge clock enable
- ◆ Global clock (0, 1, 2, or 3) with negative edge clock enable
- ◆ Global clock (0, 1, 2, or 3) with positive and negative edge clock enable (biphase)

Clock Line 2 Options

- ◆ Global clock (0, 1, 2, or 3) with clock enable

Clock Line 3 Options

- ◆ Complement of clock line 2 (same clock enable)
- ◆ Product-term clock (if clock line 2 does not use clock enable)

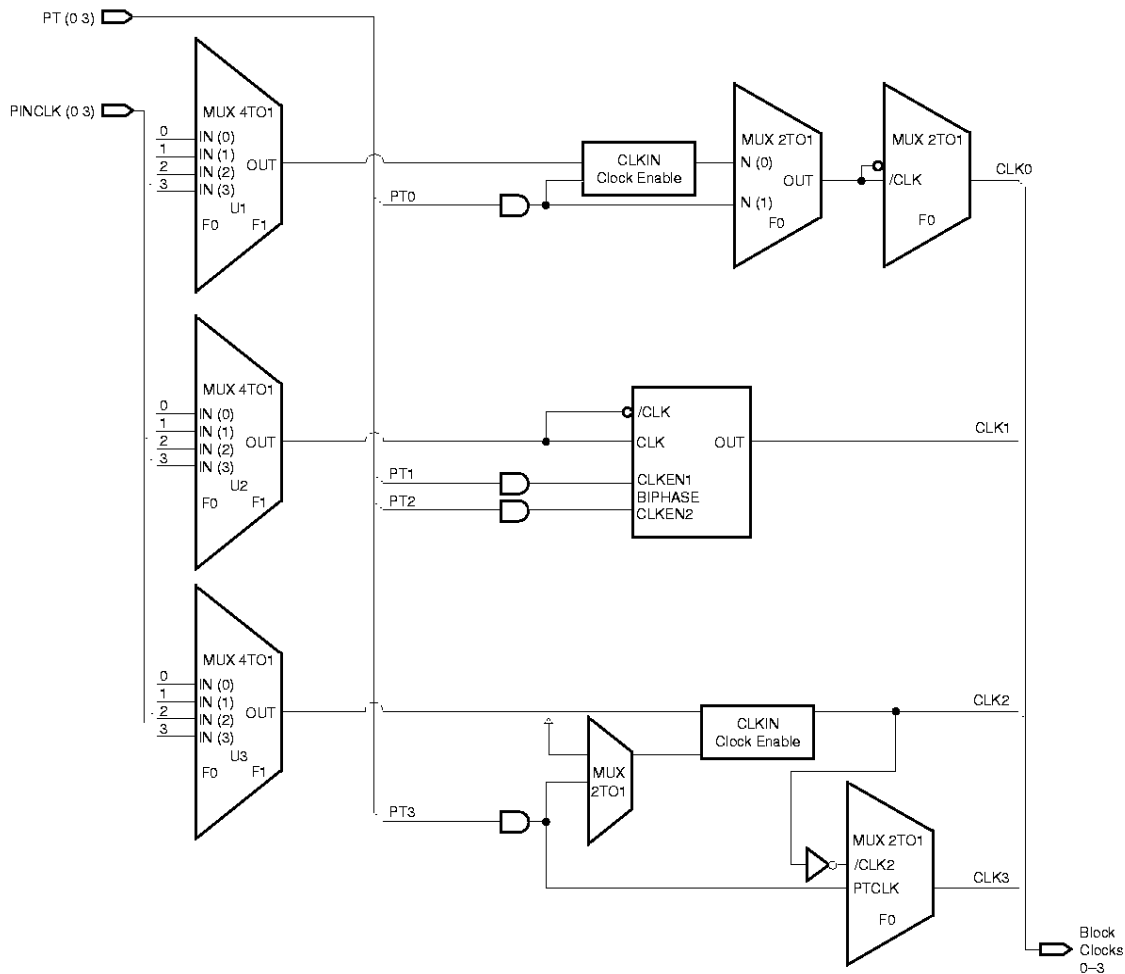

20446D-11

Figure 4. Clock Generator

Three of the four global clocks are available within any given PAL block. There are two product-term clocks and one sum-term clock available per PAL block.

The set/reset generation portion of the control generator (Figure 5) creates three set/reset lines for the PAL block. Each macrocell can choose one of these three lines or choose no set/reset at all. All three lines can be configured for product term set/reset and two of the three lines can be configured as sum term set/reset and one of the lines can be configured as product-term or sum-term latch enable. While the set/reset signals are generated in the control generator, whether that signal sets or resets a flip-flop is determined within the individual macrocell. The same signal can set one flip-flop and reset another. PT2 or /PT2 can also be used as a latch enable for macrocells configured as latches.

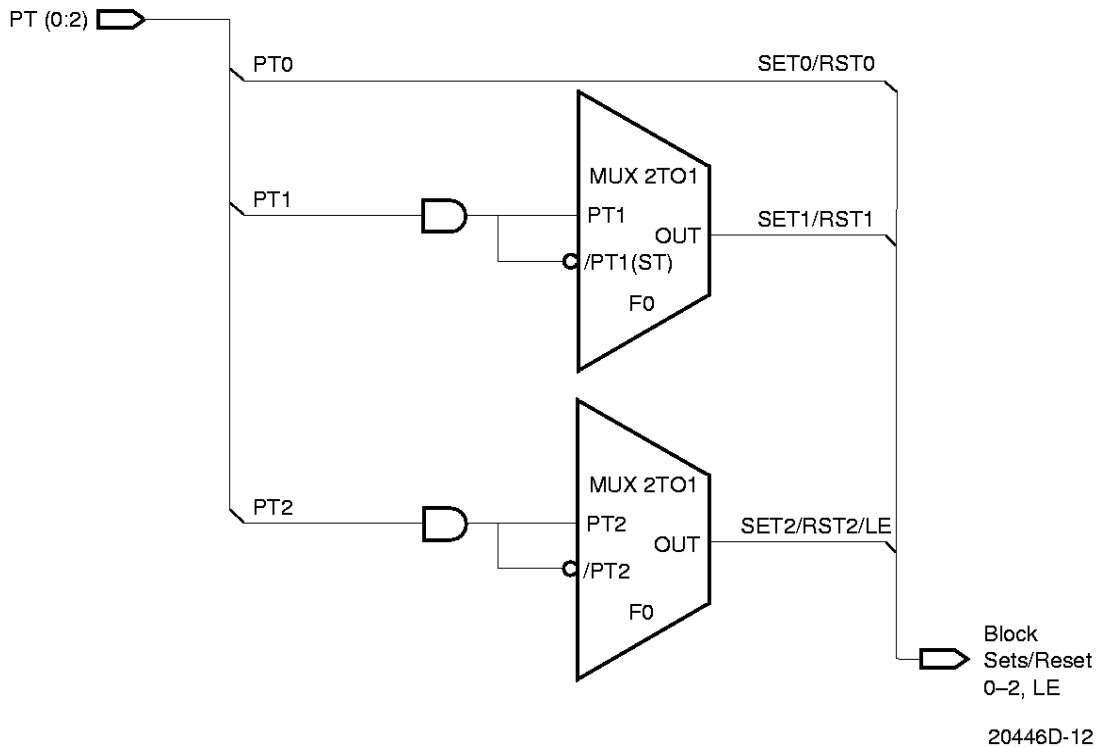

Figure 5. Set/Reset Generator

OE Generator

There is one output enable (OE) generator per PALblock that generates two product-term driven output enables. Each I/O cell is simply an output buffer. Each macrocell within the PALblock can choose to be permanently enabled, permanently disabled, or choose one of the two product term output enables per PAL block (Figure 6).

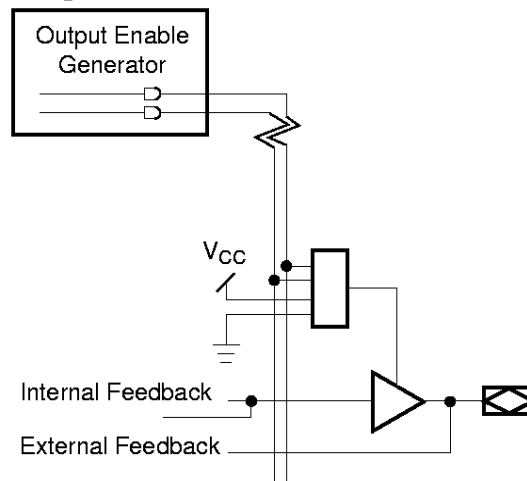

Figure 6. Output Enable Generator and I/O Cell

20446D-13

MACH 5 TIMING

MACH 5 timing can be modeled on any Vantis approved software tool or it can be estimated using the model shown in Figure 7. For more information, please see the application note *MACH 5 Timing Considerations*. Device timing will depend on the level of interconnect used and the power level chosen for a particular path. These are the path and power factors. The pin-to-pin delays can be

calculated by following one path from input/feedback to output. For example, t_{PD} is the pin-to-pin delay for a signal within a PAL block. $t_{PD}+t_{BLK}$ is the pin-to-pin delay for a signal that uses the block interconnect and stays within a segment. $t_{PD}+t_{SEG}$ is the pin-to-pin delay for a signal that uses both the block and segment interconnect. Power level timing is calculated in the same manner. If a signal uses block interconnect and is placed in a low-power block, then the pin-to-pin delay will be $t_{PD}+t_{BLK}+t_{PL3}$.

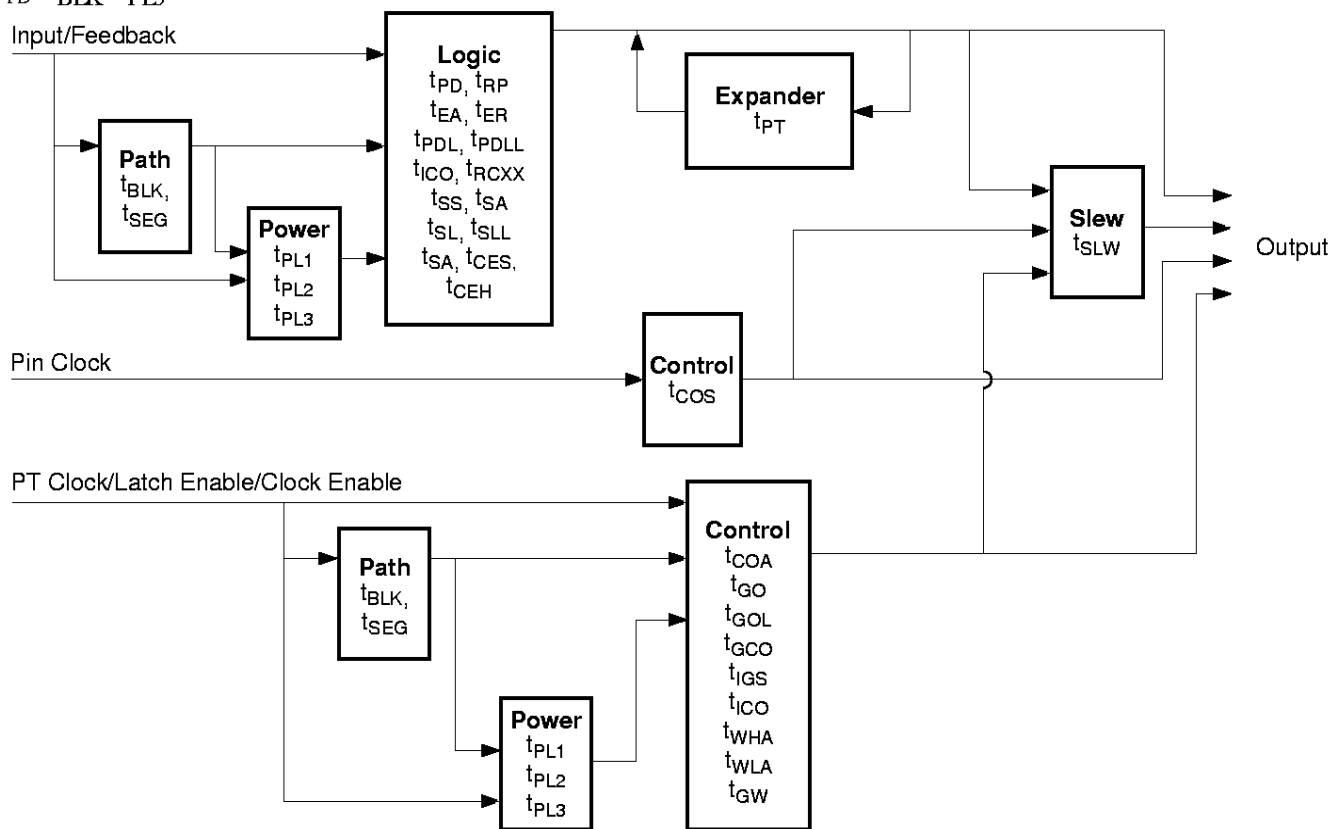

Figure 7. MACH 5 Timing Factors

20446D-14

JTAG, IN-SYSTEM PROGRAMMING

All MACH 5 devices are in-system programmable and are compliant to the JTAG standard, IEEE 1149.1, developed for checking circuit board connectivity. MACH in-system programming is implemented as an extension of this standard which uses manufacturer defined instructions and registers for program and verify. In-system programming eases prototyping and reduces manufacturing steps. The MACH 5 devices can be programmed across the commercial temperature range. Minimum programming time is typically less than 5 seconds. Vantis' MACHPRO software serializes JEDEC files and downloads them to the target board through the PC parallel port. The MACH 5 devices can be programmed in any JTAG chain.

PCI COMPLIANT

The MACH 5 family members in the -7/-10/-12 speeds are fully compliant with the *PCI Local Bus Specification* published by the PCI Special Interest Group (SIG). The MACH 5 devices provide the speed, drive, density and I/Os for the most complex PCI designs.

SAFE FOR MIXED SUPPLY VOLTAGE SYSTEM DESIGNS

All MACH 5 devices have both 3.3-V and 5-V V_{CC} versions available. Both versions are safe for mixed supply voltage system designs. The 5-V device will not overdrive 3.3-V devices above the output voltage of 3.3 V, while it accepts inputs from other 3.3-V devices. The 3.3-V device will accept inputs up to 5.5 V. Both the 5-V and 3.3-V versions have the same high-speed performance.

BUS-FRIENDLY I/O STRUCTURE

All of the MACH 5 devices have a Bus-Friendly input structure which weakly holds an input at its last driven state. While it is good design practice to tie unused pins to a known state, the Bus-Friendly input structure pulls pins away from threshold where noise can cause high-frequency switching.

MULTIPLE I/O AND DENSITY OPTIONS

As logic needs change during the design process, the MACH 5 family offers six macrocell densities and seven I/O options to optimize cost and functionality concerns.

The MACH 5 family also offers the ability to fit a working design on a member device into another device with the same number of I/Os but a different macrocell density. With proper considerations during design, this feature will allow pins to be fixed in the same locations and require no board reconfiguration.

POWER MANAGEMENT

There are 4 power/speed options in each MACH 5 PAL block. The speed and power tradeoff can be tailored for each design. In large designs, there may be several different speed requirements for different portions of a design. In a computing design, a state machine controller may require the fastest speed available, while the data path portion may run at the slower speed of the bus.

Table 4. Power Levels

High Speed/High Power	100% power
Medium High Speed/Medium High Power	67% power
Medium Low Speed/Medium Low Power	40% power
Low Speed/low Power	20% power

PROGRAMMABLE SLEW-RATE

Each MACH 5 I/O has an individual programmable slew-rate control bit. Each output can be configured for the highest speed (3 V/ns) or for the lowest noise (1 V/ns). For high-speed designs with long, unterminated traces, the slow-slew rate will introduce fewer reflections and less noise. For designs with short traces or well terminated lines, the fast-slew rate can be used to achieve the highest speed. The slew-rate is adjusted independent of power.

MACH 5 Family

POWER-UP RESET/SET

All flip-flops power up to a known state for predictable system initialization. If a macrocell is configured to SET on a signal from the control generator, then that macrocell will be SET during device power-up. If a macrocell is configured to RESET on a signal from the control generator or is not configured for set/reset, then that macrocell will RESET on power-up. To guarantee initialization values, the V_{CC} rise must be monotonic and clock must be inactive until the reset delay time has elapsed.

SECURITY

A programmable security bit is provided to prevent unauthorized copying of array configuration patterns. Once programmed, this bit defeats readback of the programmed pattern, securing proprietary designs from competitors. The security bit can only be erased in conjunction with the array during an erase cycle.

QUALITY AND TESTABILITY

The MACH 5 devices are electrically erasable which allows for full AC and DC verification of every device. In addition this verifies complete programmability and functionality of the device to provide the highest programming yields and post-programming functional yields in the industry.

TECHNOLOGY

The MACH 5 devices are fabricated on AMD's own state-of-the-art 0.5 and 0.35 micron (L_{eff}) EECMOS technologies. This advanced technology allows MACH 5 to offer both the highest performance CPLDs and the lowest power CPLDs in the industry. The floating gate cells rely on Fowler-Nordheim tunneling to charge the gates, and have long proven their endurance and reliability.

The substrate of these devices is grounded to provide substrate clamp diodes on every input which makes inputs more immune to noisy input signals.

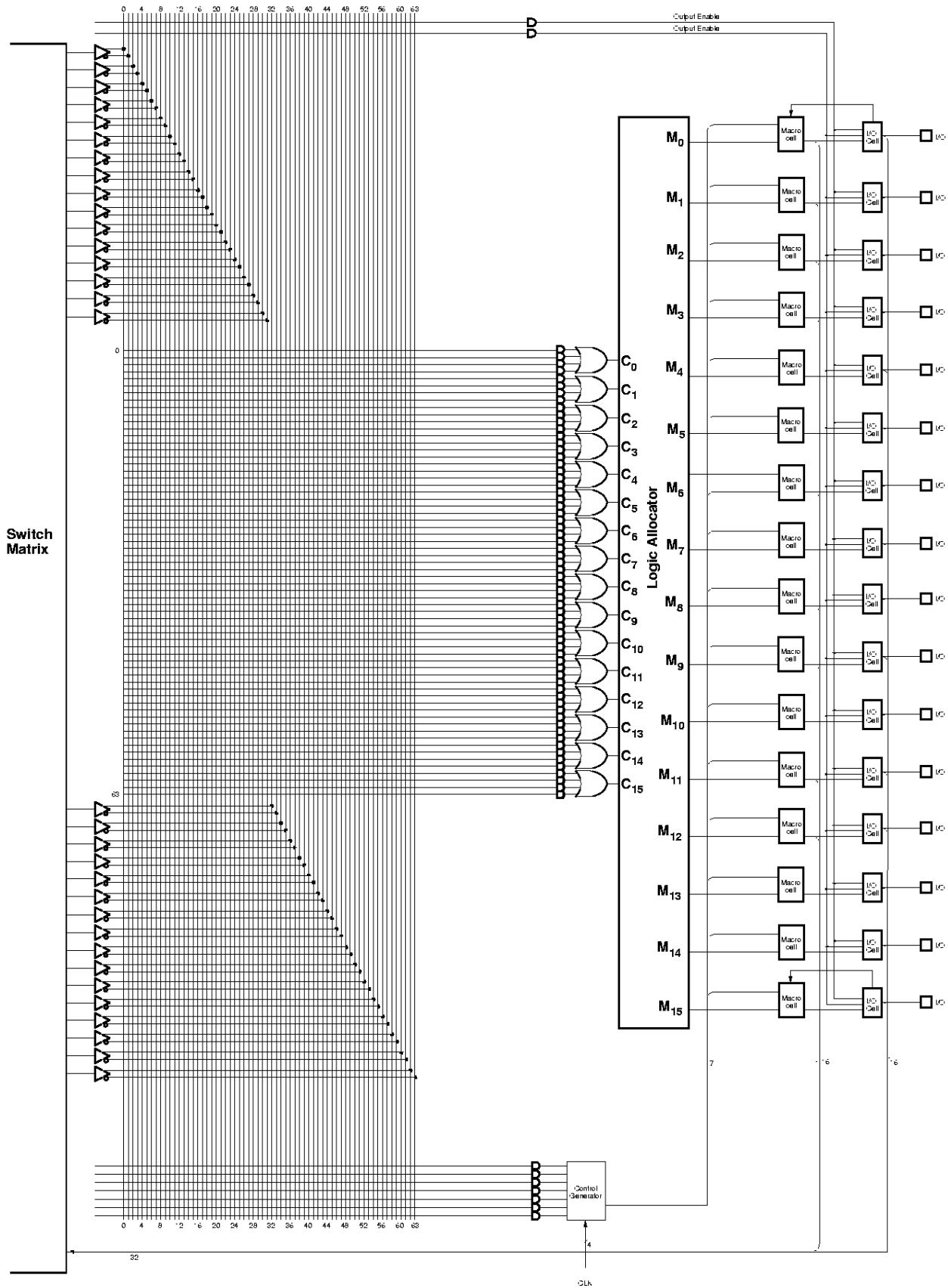

MACH 5 Family

Figure 8. MACH 5 PAL Block

20446D-15

ABSOLUTE MAXIMUM RATINGS

MACH 5 COM -7.5, -10, -12, -15

Storage Temperature -65°C to +150°C
 Device Junction Temperature +130°C to +150°C
 Supply Voltage
 with Respect to Ground -0.5 V to +7.0 V
 DC Input Voltage 0.5 V to 5.5 V
 Static Discharge Voltage 2000 V
 Latchup Current (0°C to +70°C) 200 mA

Stresses above those listed under Absolute Maximum Ratings may cause permanent device failure. Functionality at or above these limits is not implied. Exposure to Absolute Maximum Ratings for extended periods may affect device reliability.

OPERATING RANGES

Ambient Temperature (T_A)
 Operating in Free Air 0°C to +70°C
 Supply Voltage (V_{CC})
 with Respect to Ground +4.75 V to +5.25 V
Operating ranges define those limits between which the functionality of the device is guaranteed.

5-V DC CHARACTERISTICS over COMMERCIAL operating ranges

Parameter Symbol	Parameter Description	Test Description	Min	Max	Unit
V_{OH}	Output HIGH Voltage	$I_{OH} = -3.2$ mA, $V_{CC} = \text{Min}$, $V_{IN} = V_{IH}$ or V_{IL}	2.4	3.3	V
V_{OL}	Output LOW Voltage	$I_{OL} = +16$ mA, $V_{CC} = \text{Min}$, $V_{IN} = V_{IH}$ or V_{IL}		0.5	V
V_{IH}	Input HIGH Voltage	Guaranteed Input Logical HIGH Voltage for all Inputs (Note 1)	2.0		V
V_{IL}	Input LOW Voltage	Guaranteed Input Logical LOW Voltage for all Inputs (Note 1)		0.8	V
I_{IH}	Input HIGH Leakage Current	$V_{IN} = 5.25$, $V_{CC} = \text{Max}$ (Note 2)		10	μA
I_{IL}	Input LOW Leakage Current	$V_{IN} = 0$, $V_{CC} = \text{Max}$ (Note 2)		-10	μA
I_{OZH}	Off-State Output Leakage Current HIGH	$V_{OUT} = 5.25$, $V_{CC} = \text{Max}$, $V_{IN} = V_{IH}$ or V_{IL} (Note 2)		10	μA
I_{OZL}	Off-State Output Leakage Current LOW	$V_{OUT} = 0$, $V_{CC} = \text{Max}$, $V_{IN} = V_{IH}$ or V_{IL} (Note 2)		-10	μA
I_{SC}	Output Short-Circuit Current	$V_{OUT} = 0.5 V_{CC} = \text{Max}$, $V_{IN} = V_{IH}$ or V_{IL} (Note 3)	-30	-180	mA

Notes:

1. These are absolute values with respect to device ground and all overshoots due to system and/or tester noise are included.
2. I/O pin leakage is the worst case of I_{IL} and I_{OZL} or I_{IH} and I_{OZH} .
3. Not more than one output should be shorted at a time. Duration of the short-circuit should not exceed one second.

CAPACITANCE (Note 1)

Parameter Symbol	Parameter Description	Test Conditions		Typ	Unit
C_{IN}	I/CLK pin	$V_{IN} = 2.0\text{ V}$	5 V, 25°C, 1 MHz	12	pF
$C_{I/O}$	I/O pin	$V_{OUT} = 2.0\text{ V}$	5 V, 25°C, 1 MHz	10	pF

Note:

1. These parameters are not 100% tested, but are calculated at initial characterization and at any time the design is modified where frequency may be affected.

SWITCHING CHARACTERISTICS over COMMERCIAL operating ranges (Note 2) BASIC (all signals from within PAL block except global control signals)

Parameter Symbol	Parameter Description	-7		-10		-12		-15		Unit
		Min	Max	Min	Max	Min	Max	Min	Max	
t_{PD}	Input, I/O, or Feedback to Combinatorial Output	2	7.5	2	10	2	12	2	15	ns
t_{SS}	Setup Time from Input, I/O, or Feedback to Global Clock	4		5		6		8		ns
t_{HS}	Register Data Hold Time Using a Global Clock	0		0		0		0		ns
t_{COS}	Global Clock to Output (Pin Clock)		6		7		8		10	ns
t_{WLS}	Global Clock Low Width (Note 3)	3		4		5		6		ns
t_{WHS}	Global Clock High Width (Note 3)	3		4		5		6		ns
f_{MAX}	External Feedback, PAL Block Level $1/(t_{SS} + t_{COS})$	100		83		71		55		MHz
	Internal Feedback PAL Block Level	125		100		83.3		83.3		MHz
	No Feedback PAL Block Level	166.7		125		100		83.3		MHz
t_{SA}	Setup Time from Input, I/O, or Feedback to Product Term Clock, PAL Block Level	4		5		6		7		ns
t_{HA}	Output Register Data Hold Time Using a Product Term Clock	4		5		6		7		ns
t_{COA}	Product Term Clock to Output		10		12		15		17	ns
t_{WLA}	Product Term Clock Width LOW	4		5		6		7		ns
t_{WHA}	Product Term Clock Width HIGH	4		5		6		7		ns
f_{MAXA}	External Feedback, PAL Block Level $1/(t_{SA} + t_{COA})$	71		58		47.6		42		MHz
	Internal Feedback, PAL Block Level	88		72		60		52		MHz
	No Feedback, PAL Block Level	125		100		83.3		71.4		MHz
t_{SL}	Setup Time from Input, I/O, or Feedback to Product Term Gate	4		5		6		7		ns
t_{HL}	Latch Data Hold Time (Using Product Term Gate)	4		5		6		7		ns
t_{GO}	Latch Gate to Output		10		11		12		13	ns
t_{GOL}	Latch Gate to Output through Transparent Latch		17		18		19		20	ns

BASIC (all signals from within PAL block except global control signals) (Continued)

Parameter Symbol	Parameter Description	-7		-10		-12		-15		Unit
		Min	Max	Min	Max	Min	Max	Min	Max	
t_{GCO}	Latch Gate to Combinatorial Output		17		18		19		20	ns
t_{IGS}	Latch Gate to Output Latch Setup	10		11		12		13		ns
t_{GW}	Gate Width LOW (for LOW Transparent) or High (for HIGH Transparent)	4		5		6		7		ns
t_{BUF}	Delay Savings for Using Internal Feedback Instead of Pin Feedback (I/Os Only, No Savings for Buried)	0.5	2	0.5	2	0.5	2	0.5	2	ns

ASYNCHRONOUS SET and RESET, OUTPUT ENABLE, CLOCK ENABLE

Parameter Symbol	Parameter Description	-7		-10		-12		-15		Unit
		Min	Max	Min	Max	Min	Max	Min	Max	
t_{RP}	Asynchronous Reset or Preset to Registered or Latched Output		10		12		14		16	ns
t_{PRW}	Asynchronous Reset or Preset Width	4		5		6		7		ns
t_{PRR}	Asynchronous Reset or Preset Recovery Time	7.5		8		9		10		ns
t_{EA}	Input, I/O, or Feedback to Output Enable	2	9.5	2	10	2	12	2	15	ns
t_{ER}	Input, I/O, or Feedback to Output Disable		9.5		10		12		15	ns
t_{CES}	Setup Time from Clock Enable to Next Clock Pulse	4		5		7		7		ns
t_{CEH}	Hold Time for Clock Enable After Last Enabled Clock Pulse	4		5		6		6		ns
t_{RCEH}	Hold Time for Registered Clock Enable After Last Enabled Clock Pulse	0		0		0		0		ns

REGISTERS and LATCHES (input and output, BLOCK level)

Parameter Symbol	Parameter Description	-7		-10		-12		-15		Unit
		Min	Max	Min	Max	Min	Max	Min	Max	
t_{PDIL}	Input, I/O, or Feedback to Output Through Transparent Input Latch		13		15		17		19	ns
t_{ICOG}	Input Register Global Clock to Combinatorial Output		13		14		16		18	ns
t_{ICOA}	Input Register Product Term Clock to Combinatorial Output		17		18		19		20	ns
t_{SIRS}	Input Register Setup Time Using Global Clock	2		3		3		3		ns
t_{SIRA}	Input Register Setup Time Using Product Term Clock	0		0		0		0		ns
t_{HIRS}	Input Register Hold Time Using Global Clock	3		4		4		4		ns
t_{HIRA}	Input Register Hold Time Using Product Term Clock	6		7		7		7		ns
t_{WICW}	Input Register Clock Width Low or High	4		5		6		7		ns
f_{MAXI}	Maximum Input Register Frequency	125		100		83.3		71.4		MHz
t_{RCSS}	Register Using Global Clock to Output Register Using Global Clock Setup Time	9.5		12		14		17		ns
t_{RCSA}	Register Using Global Clock to Output Register Using Product Term Clock Setup Time	12.5		15		17		18		ns
t_{RCAS}	Register Using Product Term Clock to Output Register Using Global Clock Setup Time	12.5		15		17		18		ns
t_{RCAA}	Register Using Product Term Clock to Output Register Using Same Product Term Clock Setup Time	10		10		12		15		ns
t_{SIL}	Input Latch Setup Time	2		3		3		3		ns
t_{HIL}	Input Latch Hold Time	6		7		7		7		ns
t_{SLL}	Setup Time from Input, I/O, or Feedback Through Transparent Input Latch to Output Gate	9		10		11		12		ns
t_{PDLI}	Input, I/O, or Feedback to Output Through Transparent Input and Output Latches		14		16		18		20	ns

MACH5 Family

INTERCONNECT

Parameter Symbol	Parameter Description	-7		-10		-12		-15		Unit
		Min	Max	Min	Max	Min	Max	Min	Max	
t_{BLK}	Interconnect delay between blocks. If a signal depends on inputs not in the same block, but in the same segment, this delay must be added to t_{PD} , t_{SS} , t_{SA} , t_{COA} , t_{SL} , t_{GO} , t_{GOL} , t_{GCO} , t_{IGS} , t_{RP} , t_{EA} , t_{ER} , t_{CES} , t_{PDL} , t_{ICO} , t_{RCSS} , t_{RCAS} , t_{RCAA} , t_{PDL} , t_{SLL} .		1.5		2.0		2.0		2.0	ns
t_{SEG}	Interconnect delay between segments. This parameter includes all block interconnect delay. If a signal depends on inputs not in the same segment, this delay must be added to t_{PD} , t_{SS} , t_{SA} , t_{COA} , t_{SL} , t_{GO} , t_{GOL} , t_{GCO} , t_{IGS} , t_{RP} , t_{EA} , t_{ER} , t_{CES} , t_{PDL} , t_{ICO} , t_{RCSS} , t_{RCAS} , t_{RCAA} , t_{PDL} , t_{SLL} .		5		6.0		6.0		6.0	ns

POWER, LOGIC, AND SLEW (Please see individual device data sheets for details.)

Notes:

2. See *Switching Test Circuit* for test conditions.
3. If a signal is used as both a clock and a logic array input, then the maximum input frequency applies ($F_{max}/2$).

ABSOLUTE MAXIMUM RATINGS

MACH 5 LV COM -7.5, -10, -12, -15

Storage Temperature -65°C to +150°C
 Device Junction Temperature +130°C
 Supply Voltage
 with Respect to Ground -0.5 V to +7.0 V
 DC Input Voltage 0.5 V to 5.5 V
 Static Discharge Voltage 2000 V
 Latchup Current (0°C to +70°C) 200 mA

Stresses above those listed under Absolute Maximum Ratings may cause permanent device failure. Functionality at or above these limits is not implied. Exposure to Absolute Maximum Ratings for extended periods may affect device reliability.

OPERATING RANGES

Ambient Temperature (T_A)
 Operating in Free Air 0°C to +70°C
 Supply Voltage (V_{CC})
 with Respect to Ground +3.0 V to +3.6 V
Operating ranges define those limits between which the functionality of the device is guaranteed.

3.3-V DC CHARACTERISTICS over COMMERCIAL operating ranges

Parameter Symbol	Parameter Description	Test Description	Min	Max	Unit	
V_{OH}	Output HIGH Voltage	$V_{CC} = \text{Min}$ $V_{IN} = V_{IH} \text{ or } V_{IL}$	$I_{OH} = -100 \mu\text{A}$	$V_{CC} - 0.2$	V	
			$I_{OH} = 3.2 \text{ mA}$	2.4	V	
V_{OL}	Output LOW Voltage	$V_{CC} = \text{Min}$ $V_{IN} = V_{IH} \text{ or } V_{IL}$	$I_{OL} = 100 \mu\text{A}$		0.2	V
			$I_{OH} = 16 \text{ mA}$ (Note 1)		0.5	V
V_{IH}	Input HIGH Voltage	$V_{OUT} \geq V_{OH} \text{ Min or } V_{OUT} \leq V_{OL} \text{ Max}$ (Note 2)	2.0	5.5	V	
V_{IL}	Input LOW Voltage	$V_{OUT} \geq V_{OH} \text{ Min or } V_{OUT} \leq V_{OL} \text{ Max}$ (Note 2)	-0.3	0.8	V	
I_{IH}	Input HIGH Leakage Current	$V_{IN} = 3.6, V_{CC} = \text{Max}$ (Note 3)		5	μA	
I_{IL}	Input LOW Leakage Current	$V_{IN} = 0, V_{CC} = \text{Max}$ (Note 3)		-5	μA	
I_{OZH}	Off-State Output Leakage Current HIGH	$V_{OUT} = 3.6, V_{CC} = \text{Max}, V_{IN} = V_{IH} \text{ or } V_{IL}$ (Note 3)		5	μA	
I_{OZL}	Off-State Output Leakage Current LOW	$V_{OUT} = 0, V_{CC} = \text{Max}, V_{IN} = V_{IH} \text{ or } V_{IL}$ (Note 3)		-5	μA	
I_{SC}	Output Short-Circuit Current	$V_{OUT} = 0.5 V_{CC} = \text{Max}, V_{IN} = V_{IH} \text{ or } V_{IL}$ (Note 4)	-15	-160	mA	

Notes:

1. Total I_{OL} for one PAL block should not exceed 64 mA.
2. These are absolute values with respect to device ground and all overshoots due to system and/or tester noise are included.
3. I/O pin leakage is the worst case of I_{IL} and I_{OZL} or I_{IH} and I_{OZH} .
4. Not more than one output should be shorted at one time. Duration of the short-circuit should not exceed one second.

Mach5 Family

CAPACITANCE (Note 1)

Parameter Symbol	Parameter Description	Test Conditions		Typ	Unit
C_{IN}	I/CLK pin	$V_{IN} = 2.0\text{ V}$	3.3 V, 25°C, 1 MHz	12	pF
$C_{I/O}$	I/O pin	$V_{OUT} = 2.0\text{ V}$	3.3 V, 25°C, 1 MHz	10	pF

Note:

1. These parameters are not 100% tested, but are calculated at initial characterization and at any time the design is modified where frequency may be affected.

SWITCHING CHARACTERISTICS over COMMERCIAL operating ranges (Note 2) BASIC (all signals from within PAL block except global control signals)

Parameter Symbol	Parameter Description	-7		-10		-12		-15		Unit
		Min	Max	Min	Max	Min	Max	Min	Max	
t_{PD}	Input, I/O, or Feedback to Combinatorial Output	2	7.5	2	10	2	12	2	15	ns
t_{SS}	Setup Time from Input, I/O, or Feedback to Global Clock	4		5		6		8		ns
t_{HS}	Register Data Hold Time Using a Global Clock	0		0		0		0		ns
t_{COS}	Global Clock to Output (Pin Clock)		6		7		8		10	ns
t_{WLS}	Global Clock Low Width (Note 3)	3		4		5		6		ns
t_{WHS}	Global Clock High Width (Note 3)	3		4		5		6		ns
f_{MAX}	External Feedback, PAL Block Level $1/(t_{SS} + t_{COS})$	100		83		71		55		MHz
	Internal Feedback PAL Block Level	125		100		83.3		83.3		MHz
	No Feedback PAL Block Level	166.7		125		100		83.3		MHz
t_{SA}	Setup Time from Input, I/O, or Feedback to Product Term Clock, PAL Block Level	4		5		6		7		ns
t_{HA}	Output Register Data Hold Time Using a Product Term Clock	4		5		6		7		ns
t_{COA}	Product Term Clock to Output		10		12		15		17	ns
t_{WLA}	Product Term Clock Width LOW	4		5		6		7		ns
t_{WHA}	Product Term Clock Width HIGH	4		5		6		7		ns
f_{MAXA}	External Feedback, PAL Block Level $1/(t_{SA} + t_{COA})$	71		58		47.6		42		MHz
	Internal Feedback, PAL Block Level	88		72		60		52		MHz
	No Feedback, PAL Block Level	125		100		83.3		71.4		MHz
t_{SL}	Setup Time from Input, I/O, or Feedback to Product Term Gate	4		5		6		7		ns
t_{HL}	Latch Data Hold Time (Using Product Term Gate)	4		5		6		7		ns
t_{GO}	Latch Gate to Output		10		11		12		13	ns
t_{GOL}	Latch Gate to Output through Transparent Latch		17		18		19		20	ns

BASIC (all signals from within PAL block except global control signals) (Continued)

Parameter Symbol	Parameter Description	-7		-10		-12		-15		Unit
		Min	Max	Min	Max	Min	Max	Min	Max	
t_{GCO}	Latch Gate to Combinatorial Output		17		18		19		20	ns
t_{IGS}	Latch Gate to Output Latch Setup	10		11		12		13		ns
t_{GW}	Gate Width LOW (for LOW Transparent) or High (for HIGH Transparent)	4		5		6		7		ns
t_{BUF}	Delay Savings for Using Internal Feedback Instead of Pin Feedback (I/Os Only, No Savings for Buried)	0.5	2	0.5	2	0.5	2	0.5	2	ns

ASYNCHRONOUS SET and RESET, OUTPUT ENABLE, CLOCK ENABLE

Parameter Symbol	Parameter Description	-7		-10		-12		-15		Unit
		Min	Max	Min	Max	Min	Max	Min	Max	
t_{RP}	Asynchronous Reset or Preset to Registered or Latched Output		10		12		14		16	ns
t_{PRW}	Asynchronous Reset or Preset Width	4		5		6		7		ns
t_{PRR}	Asynchronous Reset or Preset Recovery Time	7.5		8		9		10		ns
t_{EA}	Input, I/O, or Feedback to Output Enable	2	9.5	2	10	2	12	2	15	ns
t_{ER}	Input, I/O, or Feedback to Output Disable		9.5		10		12		15	ns
t_{CES}	Setup Time from Clock Enable to Next Clock Pulse	5		6		7		7		ns
t_{CEH}	Hold Time for Clock Enable Following Last Enabled Clock Pulse	4		5		6		6		ns
t_{RCEH}	Hold Time for Registered Clock Enable After Last Enabled clock Edge	0		0		0		0		ns

MACH5 Family

REGISTERS and LATCHES (input and output, BLOCK level)

Parameter Symbol	Parameter Description	-7		-10		-12		-15		Unit
		Min	Max	Min	Max	Min	Max	Min	Max	
t_{PDIL}	Input, I/O, or Feedback to Output Through Transparent Input Latch		13		15		17		19	ns
t_{ICOG}	Input Register Global Clock to Combinatorial Output		13		14		16		18	ns
t_{ICOA}	Input Register Product Term Clock to Combinatorial Output		17		18		19		20	ns
t_{SIRS}	Input Register Setup Time Using Global Clock	2		3		3		3		ns
t_{SIRA}	Input Register Setup Time Using Product Term Clock	0		0		0		0		ns
t_{HIRS}	Input Register Hold Time Using Global Clock	3		4		4		4		ns
t_{HIRA}	Input Register Hold Time Using Product Term Clock	6		7		7		7		ns
t_{WICW}	Input Register Clock Width Low or High	4		5		6		7		ns
f_{MAXI}	Maximum Input Register Frequency	125		100		83.3		71.4		MHz
t_{RCSS}	Register Using Global Clock to Output Register Using Global Clock Setup Time	9.5		12		14		17		ns
t_{RCSA}	Register Using Global Clock to Output Register Using Product Term Clock Setup Time	12.5		15		17		18		ns
t_{RCAS}	Register Using Product Term Clock to Output Register Using Global Clock Setup Time	12.5		15		17		18		ns
t_{RCAA}	Register Using Product Term Clock to Output Register Using Same Product Term Clock Setup Time	10		10		12		15		ns
t_{SIL}	Input Latch Setup Time	2		3		3		3		ns
t_{HIL}	Input Latch Hold Time	6		7		7		7		ns
t_{SLL}	Setup Time from Input, I/O, or Feedback Through Transparent Input Latch to Output Gate	9		10		11		12		ns
t_{PDLL}	Input, I/O, or Feedback to Output Through Transparent Input and Output Latches		14		16		18		20	ns

INTERCONNECT

Parameter Symbol	Parameter Description	-7		-10		-12		-15		Unit
		Min	Max	Min	Max	Min	Max	Min	Max	
t_{BLK}	Interconnect delay between blocks. If a signal depends on inputs not in the same block, but in the same segment, this delay must be added to t_{PD} , t_{SS} , t_{SA} , t_{COA} , t_{SL} , t_{GO} , t_{GOL} , t_{GCO} , t_{GS} , t_{RP} , t_{EA} , t_{ER} , t_{CES} , t_{PDL} , t_{ICO} , t_{RCSS} , t_{RCAS} , t_{RCAA} , t_{PDL} , t_{SL} .		1.5		2		2		2	ns
t_{SEG}	Interconnect delay between segments. This parameter includes all block interconnect delays. If a signal depends on inputs not in the same segment, this delay must be added to t_{PD} , t_{SS} , t_{SA} , t_{COA} , t_{SL} , t_{GO} , t_{GOL} , t_{GCO} , t_{GS} , t_{RP} , t_{EA} , t_{ER} , t_{CES} , t_{PDL} , t_{ICO} , t_{RCSS} , t_{RCAS} , t_{RCAA} , t_{PDL} , t_{SL} .		5		6		6		6	ns

POWER, LOGIC, AND SLEW (Please see individual device data sheets for details.)

Notes:

2. See *Switching Test Circuit* for test conditions.
3. If a signal is used as both a clock and a logic array input, then the maximum input frequency applies ($F_{max}/2$).

MACH5 Family

ABSOLUTE MAXIMUM RATINGS

MACH 5 IND -10, -12, -15, -20

Storage Temperature -65°C to +150°C
 Device Junction Temperature +130°C to +150°C
 Supply Voltage
 with Respect to Ground -0.5 V to +7.0 V
 DC Input Voltage 0.5 V to 5.5 V
 Static Discharge Voltage 2000 V
 Latchup Current (-40°C to +85°C) 200 mA

Stresses above those listed under Absolute Maximum Ratings may cause permanent device failure. Functionality at or above these limits is not implied. Exposure to Absolute Maximum Ratings for extended periods may affect device reliability.

OPERATING RANGES

Ambient Temperature (T_A)
 Operating in Free Air -40°C to +85°C
 Supply Voltage (V_{CC})
 with Respect to Ground +4.5 V to +5.5 V
Operating ranges define those limits between which the functionality of the device is guaranteed.

5-V DC CHARACTERISTICS over INDUSTRIAL operating ranges

Parameter Symbol	Parameter Description	Test Description	Min	Max	Unit
V_{OH}	Output HIGH Voltage	$I_{OH} = -3.2$ mA, $V_{CC} = \text{Min}$, $V_{IN} = V_{IH}$ or V_{IL}	2.4	3.3	V
V_{OL}	Output LOW Voltage	$I_{OL} = +16$ mA, $V_{CC} = \text{Min}$, $V_{IN} = V_{IH}$ or V_{IL}		0.5	V
V_{IH}	Input HIGH Voltage	Guaranteed Input Logical HIGH Voltage for all Inputs (Note 1)	2.0		V
V_{IL}	Input LOW Voltage	Guaranteed Input Logical LOW Voltage for all Inputs (Note 1)		0.8	V
I_{IH}	Input HIGH Leakage Current	$V_{IN} = 5.25$, $V_{CC} = \text{Max}$ (Note 2)		10	μA
I_{IL}	Input LOW Leakage Current	$V_{IN} = 0$, $V_{CC} = \text{Max}$ (Note 2)		-10	μA
I_{OZH}	Off-State Output Leakage Current HIGH	$V_{OUT} = 5.25$, $V_{CC} = \text{Max}$, $V_{IN} = V_{IH}$ or V_{IL} (Note 2)		10	μA
I_{OZL}	Off-State Output Leakage Current LOW	$V_{OUT} = 0$, $V_{CC} = \text{Max}$, $V_{IN} = V_{IH}$ or V_{IL} (Note 2)		-10	μA
I_{SC}	Output Short-Circuit Current	$V_{OUT} = 0.5 V_{CC} = \text{Max}$, $V_{IN} = V_{IH}$ or V_{IL} (Note 3)	-30	-180	mA

Notes:

1. These are absolute values with respect to device ground and all overshoots due to system and/or tester noise are included.
2. I/O pin leakage is the worst case of I_{IL} and I_{OZL} or I_{IH} and I_{OZH} .
3. Not more than one output should be shorted at one time. Duration of the short-circuit should not exceed one second.

CAPACITANCE (Note 1)

Parameter Symbol	Parameter Description	Test Conditions		Typ	Unit
C_{IN}	I/CLK pin	$V_{IN} = 2.0 \text{ V}$	5 V, 25°C, 1 MHz	12	pF
$C_{I/O}$	I/O pin	$V_{OUT} = 2.0 \text{ V}$	5 V, 25°C, 1 MHz	10	pF

Note:

1. These parameters are not 100% tested, but are calculated at initial characterization and at any time the design is modified where frequency may be affected.

SWITCHING CHARACTERISTICS over INDUSTRIAL operating ranges (Note 2) BASIC (all signals from within PAL block except global control signals)

Parameter Symbol	Parameter Description	-10		-12		-15		-20		Unit
		Min	Max	Min	Max	Min	Max	Min	Max	
t_{PD}	Input, I/O, or Feedback to Combinatorial Output or Input, I/O, or Feedback to Output through Transparent Output Latch	2	10	2	12	2	15	2	20	ns
t_{SS}	Setup Time from Input, I/O, or Feedback to Global Clock	5		6		8		10		ns
t_{HS}	Register Data Hold Time Using a Global Clock	0		0		0		0		ns
t_{COS}	Global Clock to Output (Pin Clock)		7		8		10		12	ns
t_{WLS}	Global Clock Low Width (Note 3)	4		5		6		7		ns
t_{WHS}	Global Clock High Width (Note 3)	4		5		6		7		ns
f_{MAX}	External Feedback, PAL Block Level $1/(t_{SS} + t_{COS})$	83		71		55		45.5		MHz
	Internal Feedback PAL Block Level	100		83.3		83.3		71.4		MHz
	No Feedback PAL Block Level	125		100		83.3		71.4		MHz
t_{SA}	Setup Time from Input, I/O, or Feedback to Product Term Clock, PAL Block Level	5		6		7		8		ns
t_{HA}	Output Register Data Hold Time Using a Product Term Clock	5		6		7		8		ns
t_{COA}	Product Term Clock to Output		12		15		17		20	ns
t_{WLA}	Product Term Clock Width LOW	5		6		7		8		ns
t_{WHA}	Product Term Clock Width HIGH	5		6		7		8		ns
f_{MAXA}	External Feedback, PAL Block Level $1/(t_{SA} + t_{COA})$	58		47.6		42		35		MHz
	Internal Feedback, PAL Block Level	72		60		52		45		MHz
	No Feedback, PAL Block Level	100		83.3		71.4		62.5		MHz
t_{SL}	Setup Time from Input, I/O, or Feedback to Product Term Gate	5		6		7		8		ns
t_{HL}	Latch Data Hold Time (Using Product Term Gate)	5		6		7		8		ns
t_{GO}	Latch Gate to Output		11		12		13		14	ns

BASIC (all signals from within PAL block except global control signals) (Continued)

Parameter Symbol	Parameter Description	-10		-12		-15		-20		Unit
		Min	Max	Min	Max	Min	Max	Min	Max	
t_{GOL}	Latch (Input or Output) Gate to Output through Transparent Latch		18		19		20		21	ns
t_{GCO}	Latch Gate to Combinatorial Output		18		19		20		21	ns
t_{LGS}	Latch Gate to Output Latch Setup	11		12		13		14		ns
t_{GW}	Gate Width LOW (for LOW Transparent) or High (for HIGH Transparent)	5		6		7		8		ns
t_{BUF}	Delay Savings for Using Internal Feedback Instead of Pin Feedback (I/Os Only, No Savings for Buried)	0.5	2	0.5	2	0.5	2	0.5	2	ns

ASYNCHRONOUS SET AND RESET, OUTPUT ENABLE, CLOCK ENABLE

Parameter Symbol	Parameter Description	-10		-12		-15		-20		Unit
		Min	Max	Min	Max	Min	Max	Min	Max	
t_{RP}	Asynchronous Reset or Preset to Registered or Latched Output		12		14		16		18	ns
t_{PRW}	Asynchronous Reset or Preset Width	5		6		7		8		ns
t_{PRR}	Asynchronous Reset or Preset Recovery Time	8		9		10		11		ns
t_{EA}	Input, I/O, or Feedback to Output Enable		10		12		15		20	ns
t_{ER}	Input, I/O, or Feedback to Output Disable		10		12		15		20	ns
t_{CES}	Setup Time from Clock Enable to Next Clock Pulse	6		7		7		8		ns
t_{CEH}	Hold Time for Clock Enable After Last Enabled Clock Pulse	5		6		6		7		ns
t_{RCEH}	Hold Time for Registered Clock Enable After Last Enabled Clock Pulse	0		0		0		0		ns

REGISTERS and LATCHES (input and output, BLOCK level)

Parameter Symbol	Parameter Description	-10		-12		-15		-20		Unit
		Min	Max	Min	Max	Min	Max	Min	Max	
t_{PDIL}	Input, I/O, or Feedback to Output Through Transparent Input Latch		15		17		20		21	ns
t_{ICOG}	Input Register Global Clock to Combinatorial Output		14		16		18		20	ns
t_{ICOA}	Input Register Product Term Clock to Combinatorial Output		18		19		20		21	ns
t_{SIRS}	Input Register Setup Time Using Global Clock	3		3		3		3		ns
t_{SIRA}	Input Register Setup Time Using Product Term Clock	0		0		0		0		ns
t_{HIRS}	Input Register Hold Time Using Global Clock	4		4		4		4		ns
t_{HIRA}	Input Register Hold Time Using Product Term Clock	7		7		7		7		ns
t_{WICW}	Input Register Clock Width Low or High	5		6		7		8		ns
f_{MAXI}	Maximum Input Register Frequency	100		83.3		71.4		62.5		MHz
t_{RCSS}	Register Using Global Clock to Output Register Using Global Clock Setup Time	10		12		15		20		ns
t_{RCSA}	Register Using Global Clock to Output Register Using Product Term Clock Setup Time	15		17		18		20		ns
t_{RCAS}	Register Using Product Term Clock to Output Register Using Global Clock Setup Time	15		17		18		20		ns
t_{RCAA}	Register Using Product Term Clock to Output Register Using Same Product Term Clock Setup Time	10		12		15		20		ns
t_{SIL}	Input Latch Setup Time	3		3		3		3		ns
t_{HIL}	Input Latch Hold Time	7		7		7		7		ns
t_{SLL}	Setup Time from Input, I/O, or Feedback Through Transparent Input Latch to Output Gate	10		11		12		13		ns
t_{PDDL}	Input, I/O, or Feedback to Output Through Transparent Input and Output Latches		16		18		20		22	ns

MACH5 Family

INTERCONNECT

Parameter Symbol	Parameter Description	-10		-12		-15		-20		Unit
		Min	Max	Min	Max	Min	Max	Min	Max	
t_{BLK}	Interconnect delay between blocks. If a signal depends on inputs not in the same block, but in the same segment, this delay must be added to t_{PD} , t_{SS} , t_{SA} , t_{COA} , t_{SL} , t_{GO} , t_{GOL} , t_{GCO} , t_{IGS} , t_{RP} , t_{EA} , t_{ER} , t_{CES} , t_{PDL} , t_{ICO} , t_{RCSS} , t_{RCAS} , t_{RCAA} , t_{PDL} , t_{SLL} .		2.0		2.0		2.0		2.0	ns
t_{SEG}	Interconnect delay between segments. This parameter includes all block interconnect delay. If a signal depends on inputs not in the same segment, this delay must be added to t_{PD} , t_{SS} , t_{SA} , t_{COA} , t_{SL} , t_{GO} , t_{GOL} , t_{GCO} , t_{IGS} , t_{RP} , t_{EA} , t_{ER} , t_{CES} , t_{PDL} , t_{ICO} , t_{RCSS} , t_{RCAS} , t_{RCAA} , t_{PDL} , t_{SLL} .		6		6		6		6	ns

POWER, LOGIC, AND SLEW (Please see individual device data sheets for details.)

Notes:

2. See *Switching Test Circuit* for test conditions.
3. If a signal is used as both a clock and a logic array input, then the maximum input frequency applies ($F_{max}/2$).

ABSOLUTE MAXIMUM RATINGS

MACH 5 LV IND -10, -12, -15, -20

Storage Temperature	-65°C to +150°C
Device Junction Temperature	+130°C
Supply Voltage with Respect to Ground	-0.5 V to +7.0 V
DC Input Voltage	0.5 V to 5.5 V
Static Discharge Voltage	2000 V
Latchup Current (0°C to +70°C)	200 mA

Stresses above those listed under Absolute Maximum Ratings may cause permanent device failure. Functionality at or above these limits is not implied. Exposure to Absolute Maximum Ratings for extended periods may affect device reliability.

OPERATING RANGES

Ambient Temperature (T_A) Operating in Free Air	-40°C to +85°C
Supply Voltage (V_{CC}) with Respect to Ground	+3.0 V to +3.6 V

Operating ranges define those limits between which the functionality of the device is guaranteed.

3.3-V DC CHARACTERISTICS over INDUSTRIAL operating ranges

Parameter Symbol	Parameter Description	Test Description	Min	Max	Unit
V_{OH}	Output HIGH Voltage	$V_{CC} = \text{Min}$ $I_{OH} = -100 \mu\text{A}$	$V_{CC} - 0.2$		V
		$V_{IN} = V_{IH} \text{ or } V_{IL}$ $I_{OH} = 3.2 \text{ mA}$	2.4		V
V_{OL}	Output LOW Voltage	$V_{CC} = \text{Min}$ $I_{OL} = 100 \mu\text{A}$			V
		$V_{IN} = V_{IH} \text{ or } V_{IL}$ $I_{OH} = 16 \text{ mA}$ (Note 1)			V
V_{IH}	Input HIGH Voltage	$V_{OUT} \geq V_{OH} \text{ Min or } V_{OUT} \leq V_{OL} \text{ Max}$ (Note 2)	2.0	5.5	V
V_{IL}	Input LOW Voltage	$V_{OUT} \geq V_{OH} \text{ Min or } V_{OUT} \leq V_{OL} \text{ Max}$ (Note 2)	-0.3	0.8	V
I_{IH}	Input HIGH Leakage Current	$V_{IN} = 3.6, V_{CC} = \text{Max}$ (Note 3)		5	μA
I_{IL}	Input LOW Leakage Current	$V_{IN} = 0, V_{CC} = \text{Max}$ (Note 3)		-5	μA
I_{OZH}	Off-State Output Leakage Current HIGH	$V_{OUT} = 3.6, V_{CC} = \text{Max}, V_{IN} = V_{IH} \text{ or } V_{IL}$ (Note 2)		5	μA
I_{OZL}	Off-State Output Leakage Current LOW	$V_{OUT} = 0, V_{CC} = \text{Max}, V_{IN} = V_{IH} \text{ or } V_{IL}$ (Note 2)		-5	μA
I_{SC}	Output Short-Circuit Current	$V_{OUT} = 0.5 V_{CC} = \text{Max}, V_{IN} = V_{IH} \text{ or } V_{IL}$ (Note 3)	-15	-160	mA

Notes:

1. These are absolute values with respect to device ground and all overshoots due to system and/or tester noise are included.
2. I/O pin leakage is the worst case of I_{IL} and I_{OZL} or I_{IH} and I_{OZH} .
3. Not more than one output should be shorted at one time. Duration of the short-circuit should not exceed one second.

Mach5 Family

CAPACITANCE (Note 1)

Parameter Symbol	Parameter Description	Test Conditions		Typ	Unit
C_{IN}	I/CLK pin	$V_{IN} = 2.0\text{ V}$	3.3 V, 25°C, 1 MHz	12	pF
$C_{I/O}$	I/O pin	$V_{OUT} = 2.0\text{ V}$	3.3 V, 25°C, 1 MHz	10	pF

Note:

1. These parameters are not 100% tested, but are calculated at initial characterization and at any time the design is modified where frequency may be affected.

SWITCHING CHARACTERISTICS over INDUSTRIAL operating ranges (Note 2) BASIC (all signals from within PAL block except global control signals)

Parameter Symbol	Parameter Description	-10		-12		-15		-20		Unit
		Min	Max	Min	Max	Min	Max	Min	Max	
t_{PD}	Input, I/O, or Feedback to Combinatorial Output or Input, I/O, or Feedback to Output through Transparent Output Latch	2	10	2	12	2	15	2	20	ns
t_{SS}	Setup Time from Input, I/O, or Feedback to Global Clock	5		6		8		10		ns
t_{HS}	Register Data Hold Time Using a Global Clock	0		0		0		0		ns
t_{COS}	Global Clock to Output (Pin Clock)		7		8		10		12	ns
t_{WLS}	Global Clock Low Width (Note 3)	4		5		6		7		ns
t_{WHS}	Global Clock High Width (Note 3)	4		5		6		7		ns
f_{MAX}	External Feedback, PAL Block Level $1/(t_{SS} + t_{COS})$	83		71		55		45.5		MHz
	Internal Feedback PAL Block Level	100		83.3		83.3		71.4		MHz
	No Feedback PAL Block Level	125		100		83.3		71.4		MHz
t_{SA}	Setup Time from Input, I/O, or Feedback to Product Term Clock, PAL Block Level	5		6		7		8		ns
t_{HA}	Output Register Data Hold Time Using a Product Term Clock	5		6		7		8		ns
t_{COA}	Product Term Clock to Output		12		15		17		20	ns
t_{WLA}	Product Term Clock Width LOW	5		6		7		8		ns
t_{WHA}	Product Term Clock Width HIGH	5		6		7		8		ns
f_{MAXA}	External Feedback, PAL Block Level $1/(t_{SA} + t_{COA})$	58		47.6		42		35		MHz
	Internal Feedback, PAL Block Level	72		60		52		45		MHz
	No Feedback, PAL Block Level	100		83.3		71.4		62.5		MHz
t_{SL}	Setup Time from Input, I/O, or Feedback to Product Term Gate	5		6		7		8		ns
t_{HL}	Latch Data Hold Time (Using Product Term Gate)	5		6		7		8		ns
t_{GO}	Latch Gate to Output		11		12		13		14	ns

BASIC (all signals from within PAL block except global control signals) (Continued)

Parameter Symbol	Parameter Description	-10		-12		-15		-20		Unit
		Min	Max	Min	Max	Min	Max	Min	Max	
t_{GOL}	Latch Gate to Output through Transparent Latch		18		19		20		21	ns
t_{GCO}	Latch Gate to Combinatorial Output		18		19		20		21	ns
t_{LGS}	Latch Gate to Output Latch Setup	11		12		13		14		ns
t_{GW}	Gate Width LOW (for LOW Transparent) or High (for HIGH Transparent)	5		6		7		8		ns
t_{BUF}	Delay Savings for Using Internal Feedback Instead of Pin Feedback (I/Os Only, No Savings for Buried)	0.5	2	0.5	2	0.5	2	0.5	2	ns

ASYNCHRONOUS SET and RESET, OUTPUT ENABLE, CLOCK ENABLE

Parameter Symbol	Parameter Description	-10		-12		-15		-20		Unit
		Min	Max	Min	Max	Min	Max	Min	Max	
t_{RP}	Asynchronous Reset or Preset to Registered or Latched Output		12		14		16		18	ns
t_{PRW}	Asynchronous Reset or Preset Width	5		6		7		8		ns
t_{PRR}	Asynchronous Reset or Preset Recovery Time	8		9		10		11		ns
t_{EA}	Input, I/O, or Feedback to Output Enable	2	10	2	12	2	15	2	20	ns
t_{ER}	Input, I/O, or Feedback to Output Disable		10		12		15		20	ns
t_{CES}	Setup Time from Clock Enable to Next Clock Pulse	6		7		7		8		ns
t_{CEH}	Hold Time for Clock Enable Following Last Enabled Clock Pulse	5		6		6		7		ns
t_{RCEH}	Hold Time for Registered Clock Enable After Last Enabled Clock Edge	0		0		0		0		ns

MACH5 Family

REGISTERS and LATCHES (input and output, BLOCK level)

Parameter Symbol	Parameter Description	-10		-12		-15		-20		Unit
		Min	Max	Min	Max	Min	Max	Min	Max	
t_{PDIL}	Input, I/O, or Feedback to Output Through Transparent Input Latch		15		17		20		21	ns
t_{ICOG}	Input Register Global Clock to Combinatorial Output		14		16		18		20	ns
t_{ICOA}	Input Register Product Term Clock to Combinatorial Output		18		19		20		21	ns
t_{SIRS}	Input Register Setup Time Using Global Clock	3		3		3		3		ns
t_{SIRA}	Input Register Setup Time Using Product Term Clock	0		0		0		0		ns
t_{HIRS}	Input Register Hold Time Using Global Clock	4		4		4		4		ns
t_{HIRA}	Input Register Hold Time Using Product Term Clock	7		7		7		7		ns
t_{WICW}	Input Register Clock Width Low or High	5		6		7		8		ns
f_{MAXI}	Maximum Input Register Frequency	100		83.3		71.4		62.5		MHz
t_{RCSS}	Register Using Global Clock to Output Register Using Global Clock Setup Time	10		12		15		20		ns
t_{RCSA}	Register Using Global Clock to Output Register Using Product Term Clock Setup Time	15		17		18		20		ns
t_{RCAS}	Register Using Product Term Clock to Output Register Using Global Clock Setup Time	15		17		18		20		ns
t_{RCAA}	Register Using Product Term Clock to Output Register Using Same Product Term Clock Setup Time	10		12		15		20		ns
t_{SL}	Input Latch Setup Time	3		3		3		3		ns
t_{HIL}	Input Latch Hold Time	7		7		7		7		ns
t_{SLL}	Setup Time from Input, I/O, or Feedback Through Transparent Input Latch to Output Gate	10		11		12		13		ns

INTERCONNECT

Parameter Symbol	Parameter Description	-10		-12		-15		-20		Unit
		Min	Max	Min	Max	Min	Max	Min	Max	
t_{BLK}	Interconnect delay between blocks. If a signal depends on inputs not in the same block, but in the same segment, this delay must be added to t_{PD} , t_{SS} , t_{SA} , t_{COA} , t_{SL} , t_{GO} , t_{GOL} , t_{GCO} , t_{IGS} , t_{RP} , t_{EA} , t_{ER} , t_{CES} , t_{PDL} , t_{ICO} , t_{RCSS} , t_{RCAS} , t_{RCAA} , t_{PDL} , t_{SLL} .		2.0		2.0		2.0		2.0	ns
t_{SEG}	Interconnect delay between segments. This parameter includes all block interconnect delay. If a signal depends on inputs not in the same segment, this delay must be added to t_{PD} , t_{SS} , t_{SA} , t_{COA} , t_{SL} , t_{GO} , t_{GOL} , t_{GCO} , t_{IGS} , t_{RP} , t_{EA} , t_{ER} , t_{CES} , t_{PDL} , t_{ICO} , t_{RCSS} , t_{RCAS} , t_{RCAA} , t_{PDL} , t_{SLL} .		6		6		6		6	ns

POWER, LOGIC, AND SLEW (Please see individual device data sheets for details.)

Notes:

- See *Switching Test Circuit* for test conditions.
- If a signal is used as both a clock and a logic array input, then the maximum input frequency applies ($F_{max}/2$).

I_{CC} vs. FREQUENCY

These curves represent the typical power consumption for a particular device at system frequency. The selected “typical” pattern is a 16-bit up-down counter. This pattern fills the device and exercises every macrocell. Maximum frequency shown uses internal feedback and a D-type register. Power/Speed are optimized to obtain the highest counter frequency and the lowest power. The highest frequency (LSBs) is placed in common PAL blocks, which are set to high power. The lowest frequency signals (MSBs) are placed in a common PAL block and set to lowest power.

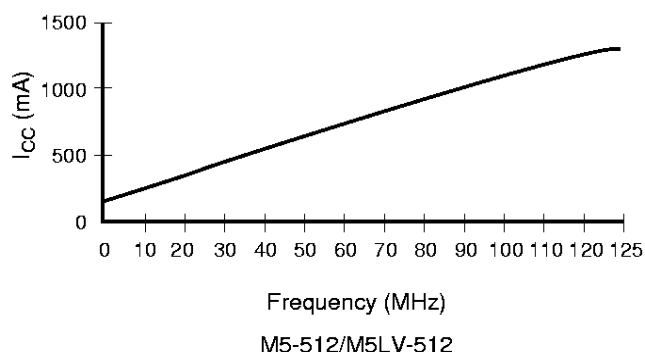
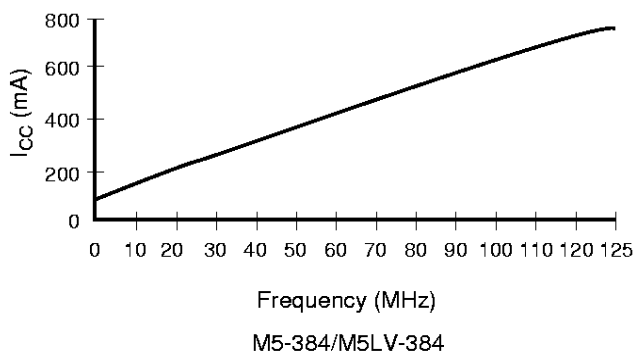
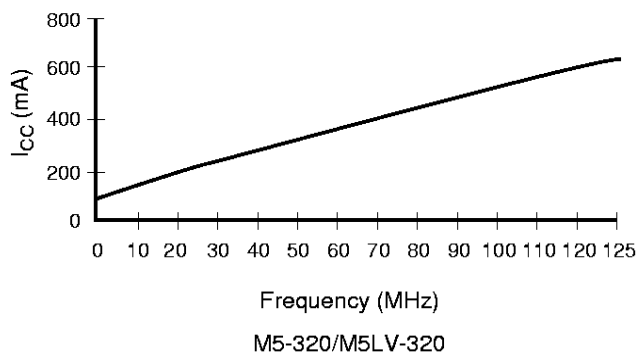
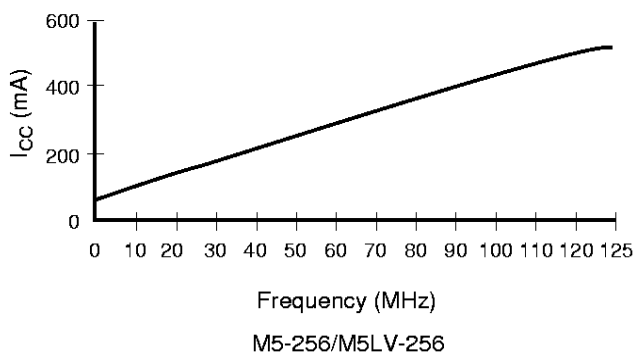
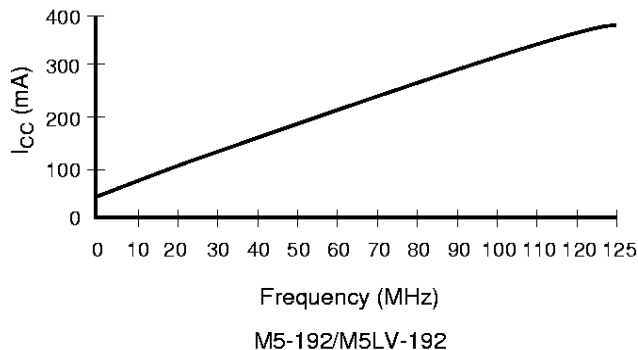
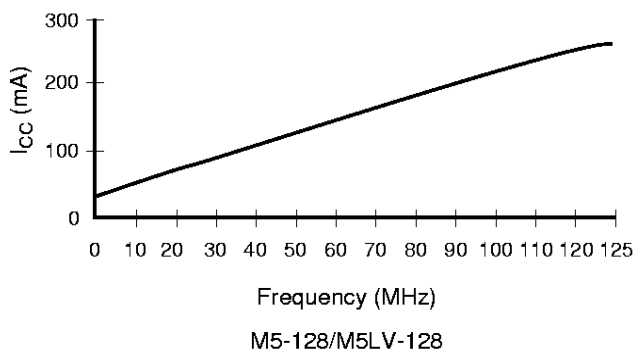

SWITCHING TEST CIRCUIT

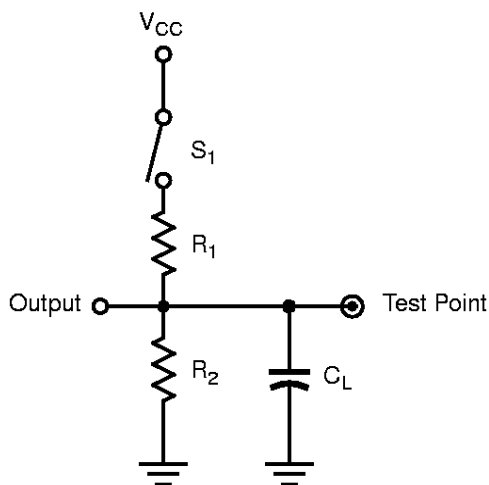

20446D-17

Specification	S ₁	C _L	Commercial		Measured Output Value
			R ₁	R ₂	
t _{PD} , t _{CO}	Closed	35 pF (30 pF)	300 Ω (1.6 KΩ)	390 Ω (1.6 KΩ)	1.5 V
t _{EA}	Z → H: Open Z → L: Closed				
t _{ER}	H → Z: Open L → Z: Closed	5 pF			H → Z: V _{OH} - 0.5 V L → Z: V _{OL} + 0.5 V

* Switching several outputs simultaneously should be avoided for accurate measurement.

Values in parentheses are for 3.3-V devices.

MACH5 Family

f_{MAX} PARAMETERS

The parameter f_{MAX} is the maximum clock rate at which the device is guaranteed to operate. Because the flexibility inherent in programmable logic devices offers a choice of clocked flip-flop designs, f_{MAX} is specified for three types of synchronous designs.

The first type of design is a state machine with feedback signals sent off-chip. This external feedback could go back to the device inputs, or to a second device in a multi-chip state machine. The slowest path defining the period is the sum of the clock-to-output time and the input setup time for the external signals ($t_s + t_{CO}$). The reciprocal, f_{MAX} , is the maximum frequency with external feedback or in conjunction with an equivalent speed device. This f_{MAX} is designated “ f_{MAX} external.”

The second type of design is a single-chip state machine with internal feedback only. In this case, flip-flop inputs are defined by the device inputs and flip-flop outputs. Under these conditions, the period is limited by the internal delay from the flip-flop outputs through the internal feedback and logic to the flip-flop inputs. This f_{MAX} is designated “ f_{MAX} internal”. A simple internal counter is a good example of this type of design; therefore, this parameter is sometimes called “ f_{CNT} .”

The third type of design is a simple data path application. In this case, input data is presented to the flip-flop and clocked through; no feedback is employed. Under these conditions, the period is limited by the sum of the data setup time and the data hold time ($t_s + t_H$). However, a lower limit for the period of each f_{MAX} type is the minimum clock period ($t_{WH} + t_{WL}$). Usually, this minimum clock period determines the period for the third f_{MAX} , designated “ f_{MAX} no feedback.”

For devices with input registers, one additional f_{MAX} parameter is specified: f_{MAXIR} . Because this involves no feedback, it is calculated the same way as f_{MAX} no feedback. The minimum period will be limited either by the sum of the setup and hold times ($t_{SIR} + t_{HIR}$) or the sum of the clock widths ($t_{WICL} + t_{WICH}$). The clock widths are normally the limiting parameters, so that f_{MAXIR} is specified as $1/(t_{WICL} + t_{WICH})$. Note that if both input and output registers are used in the same path, the overall frequency will be limited by t_{ICS} . All frequencies except f_{MAX} internal are calculated from other measured AC parameters. f_{MAX} internal is measured directly.

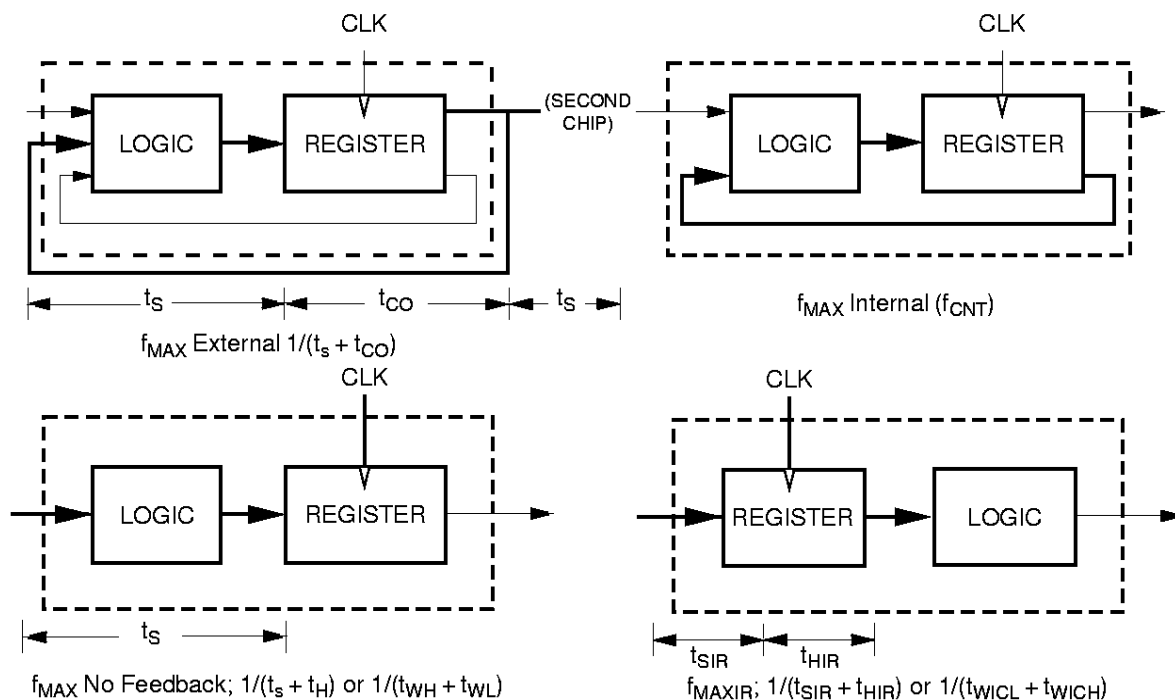

20446D-18

ENDURANCE CHARACTERISTICS

The MACH families are manufactured using Vantis' advanced Electrically Erasable process. This technology uses an EE cell to replace the fuse link used in bipolar parts. As a result, the device can be erased and reprogrammed, a feature which allows 100% testing at the factory.

Endurance Characteristics

Parameter Symbol	Parameter Description		Units	Test Conditions
t_{DR}	Min Pattern Data Retention Time	10	Years	Max Storage Temperature
		20	Years	Max Operating Temperature
N	Max Reprogramming Cycles	100	Cycles	Normal Programming Conditions

INPUT/OUTPUT EQUIVALENT SCHEMATICS

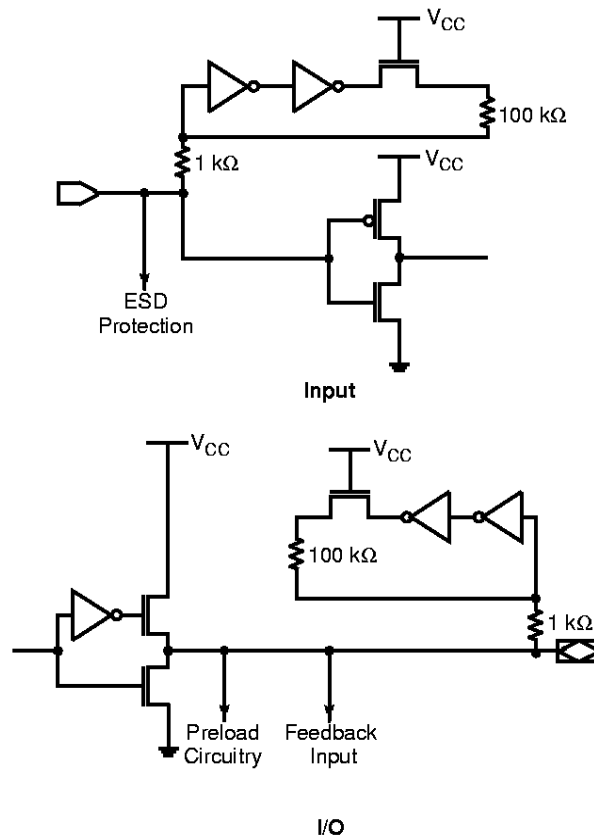

20446D-19

POWER-UP RESET

The MACH devices have been designed with the capability to reset during system power-up. Following power-up, all flip-flops will be reset to LOW. The output state will depend on the logic polarity. This feature provides extra flexibility to the designer and is especially valuable in simplifying state machine initialization. A timing diagram and parameter table are shown below. Due to the synchronous operation of the power-up reset and the wide range of ways V_{CC} can rise to its steady state, two conditions are required to insure a valid power-up reset. These conditions are:

1. The V_{CC} rise must be monotonic.
2. Following reset, the clock input must not be driven from LOW to HIGH until all applicable input and feedback setup times are met.

Parameter Symbol	Parameter Descriptions	Max	Unit
t_{PR}	Power-Up Reset Time	10	μs
t_S	Input or Feedback Setup Time	See Switching Characteristics	
t_{WL}	Clock Width LOW		

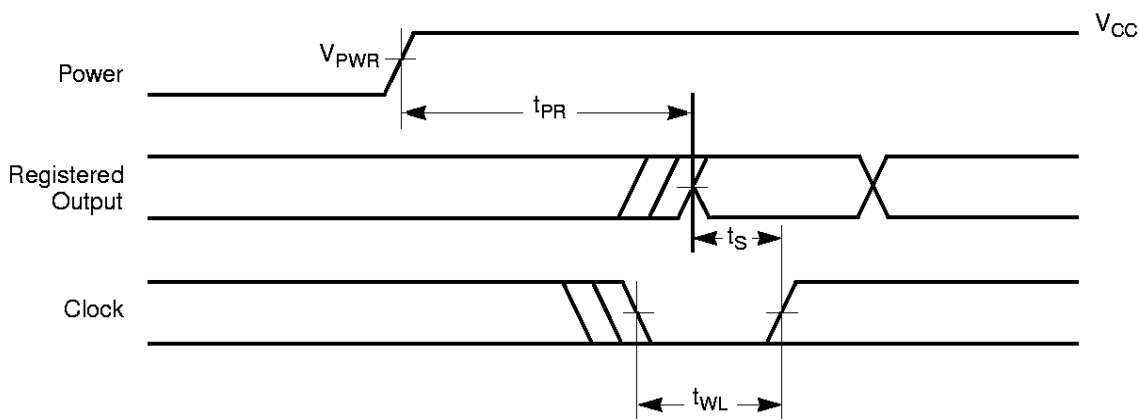

20446D-20

Power-Up Reset Waveform

$V_{PWR} = 4\text{ V}$ for 5-V devices and 2.7 for 3.3-V devices.

DEVELOPMENT SYSTEMS (subject to change)

For more information on the products listed below, please consult the local Vantis sales office.

MANUFACTURER	SOFTWARE DEVELOPMENT SYSTEMS
Vantis Corporation P.O. Box 3755 920 DeGuigne Drive Sunnyvale, CA 94088 (408) 732-0555 or 1(888) 826-8472 (VANTIS2) http://www.vantis.com	MACHXL Software Vantis-ABEL Software Vantis-Synario Software
Aldec, Inc. 3 Sunset Way, Suite F Henderson, NV 89014 (702) 456-1222 or (800) 487-8743	ACTIVE-CAD
Cadence Design Systems 555 River Oaks Pkwy San Jose, CA 95134 (408) 943-1234 or (800) 746-6223	PIC Designer Concept/Composer Synergy Leapfrog/Verilog-XL
Exemplar Logic, Inc. 815 Atlantic Avenue, Suite 105 Alameda, CA 94501 (510) 337-3700	Leonardo™ Galileo™
Logic Modeling 19500 NW Gibbs Dr. P.O. Box 310 Beaverton, OR 97075 (800) 346-6335	SmartModel® Library
Mentor Graphics Corp. 8005 S.W. Boeckman Rd. Wilsonville, OR 97070-7777 (800) 547-3000 or (503) 685-7000	Design Architect, PLDSynthesis™ II Autologic II Synthesizer, QuickSim Simulator, QuickHDL Simulator
MicroSim Corp. 20 Fairbanks Irvine, CA 92718 (714) 770-3022	MicroSim Design Lab PLogic, PLSyn
MNC Inc. 6755 Earl Drive, Suite 200 Colorado Springs, CO 80918 (800) 755-FPGA or (719) 590-1155	PLDesigner-XL™ Software
Model Technology 8905 S.W. Nimbus Avenue, Suite 150 Beaverton, OR 97008 (503) 641-1340	V-System/VHDL
OrCAD, Inc. 9300 S.W. Nimbus Avenue Beaverton, OR 97008 (503) 671-9500 or (800) 671-9505	OrCAD Express
Synario® Design Automation 10525 Willows Road N.E. P.O. Box 97046 Redmond, WA 98073-9746 (800) 332-8246 or (206) 881-6444	ABEL™ Synario™ Software

MACH5 Family



MANUFACTURER	SOFTWARE DEVELOPMENT SYSTEMS
Synopsys 700 E. Middlefield Rd. Mountain View, CA 94040 (415) 962-5000 or (800) 388-9125	FPGA or Design Compiler (Requires MINC PLDesigner-XL™) VSS Simulator
Synplicity, Inc. 624 East Evelyn Ave. Sunnyvale, CA 94086 (408) 617-6000	Synplify
Teradyne EDA 321 Harrison Ave. Boston, MA 02118 (800) 777-2432 or (617) 422-2793	MultiSIM Interactive Simulator LASAR
VeriBest, Inc. 6101 Lookout Road, Suite A Boulder, CO 80301 (800) 837-4237	VeriBest PLD
Viewlogic Systems, Inc. 293 Boston Post Road West Marlboro, MA 01752 (800) 873-8439 or (508) 480-0881	Viewdraw, ViewPLD, Viewsynthesis Speedwave Simulator, ViewSim Simulator, VCS Simulator
MANUFACTURER	TEST GENERATION SYSTEM
Acugen Software, Inc. 427-3 Amherst St., Suite 391 Nashua, NH 03063 (603) 881-8821	ATGEN™ Test Generation Software
iNt GmbH Busenstrasse 6 D-8033 Martinsried, Munich, Germany (87) 857-6667	PLDCheck 90

Vantis is not responsible for any information relating to the products of third parties. The inclusion of such information is not a representation nor an endorsement by Vantis of these products.

APPROVED PROGRAMMERS (subject to change)

For more information on the products listed below, please consult the local Vantis sales office.

MANUFACTURER	PROGRAMMER CONFIGURATION
Advin Systems, Inc. 1050-L East Duane Ave. Sunnyvale, CA 940 86 (408) 243-7000 or (800) 627-2456 BBS (408) 737-9200 Fax (408) 736-2503	Pilot-U40 Pilot-U84 MVP
BP Microsystems 1000 N. Post Oak Rd., Suite 225 Houston, TX 77055-7237 (800) 225-2102 or (713) 688-4600 BBS (713) 688-9283 Fax (713) 688-0920	BP1200 BP1400 BP2100 BP2200
Data I/O Corporation 10525 Willows Road N.E. P.O. Box 97046 Redmond, WA 98073-9746 (800) 426-1045 or (206) 881-6444 BBS (206) 882-3211 Fax (206) 882-1043	UniSite™ Model 2900 Model 3900 AutoSite
Hi-Lo Systems 4F, No. 2, Sec. 5, Ming Shoh E. Road Taipei, Taiwan (886) 2-764-0215 Fax (886) 2-756-6403 or Tribal Microsystems / Hi-Lo Systems 44388 South Grimmer Blvd. Fremont, CA 94538 (510) 623-8859 BBS (510) 623-0430 Fax (510) 623-9925	ALL-07 FLEX-700
SMS GmbH Im Grund 15 88239 Wangen Germany (49) 7522-97280 Fax (49) 7522-972850 or SMS USA 544 Weddell Dr. Suite 12 Sunnyvale, CA 94089 (408) 542-0388	Sprint Expert Sprint Optima Multisite
Stag House Silver Court Watchmead, Welwyn Garden City Herfordshire UK AL7 1LT 44-1-707-332148 Fax 44-1-707-371503	Stag Quazar

MACH 5 Family



MANUFACTURER	PROGRAMMER CONFIGURATION
System General 1603A South Main Street Milpitas, CA 95035 (408) 263-6667 BBS (408) 262-6438 Fax (408) 262-9220 or 3F, No. 1, Alley 8, Lane 45 Bao Shing Road, Shin Diao Taipei, Taiwan (886) 2-917-3005 Fax (886) 2-911-1283	Turpro-1 Turpro-1/EX Turpro-1/TX

APPROVED ADAPTER MANUFACTURERS

MANUFACTURER	PROGRAMMER CONFIGURATION
California Integration Coordinators, Inc. 656 Main Street Placerville, CA 95667 (916) 626-6168 Fax (916) 626-7740	MACH/PAL Programming Adapters
Emulation Technology, Inc. 2344 Walsh Ave., Bldg. F Santa Clara, CA 95051 (408) 982-0660 Fax (408) 982-0664	Adapt-A-Socket® Programming Adapters

APPROVED ON-BOARD ISP PROGRAMMING TOOLS

MANUFACTURER	PROGRAMMER CONFIGURATION
Corelis, Inc. 12607 Hidden Creek Way, Suite H Cerritos, California 70703 (310) 926-6727	JTAGPROG™
Vantis Corporation P.O. Box 3755 920 DeGuigne Drive Sunnyvale, CA 94088 (408) 732-0555 or 1(888) 826-8472 (VANTIS2) http://www.vantis.com	MACHPRO®

PHYSICAL DIMENSIONS

PQR100

100-Pin Plastic Quad Flat Pack; Trimmed and Formed (measured in millimeters)

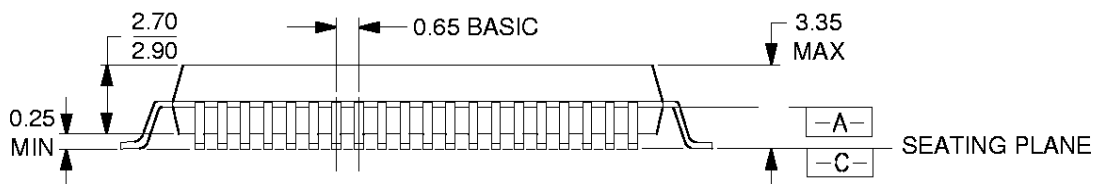
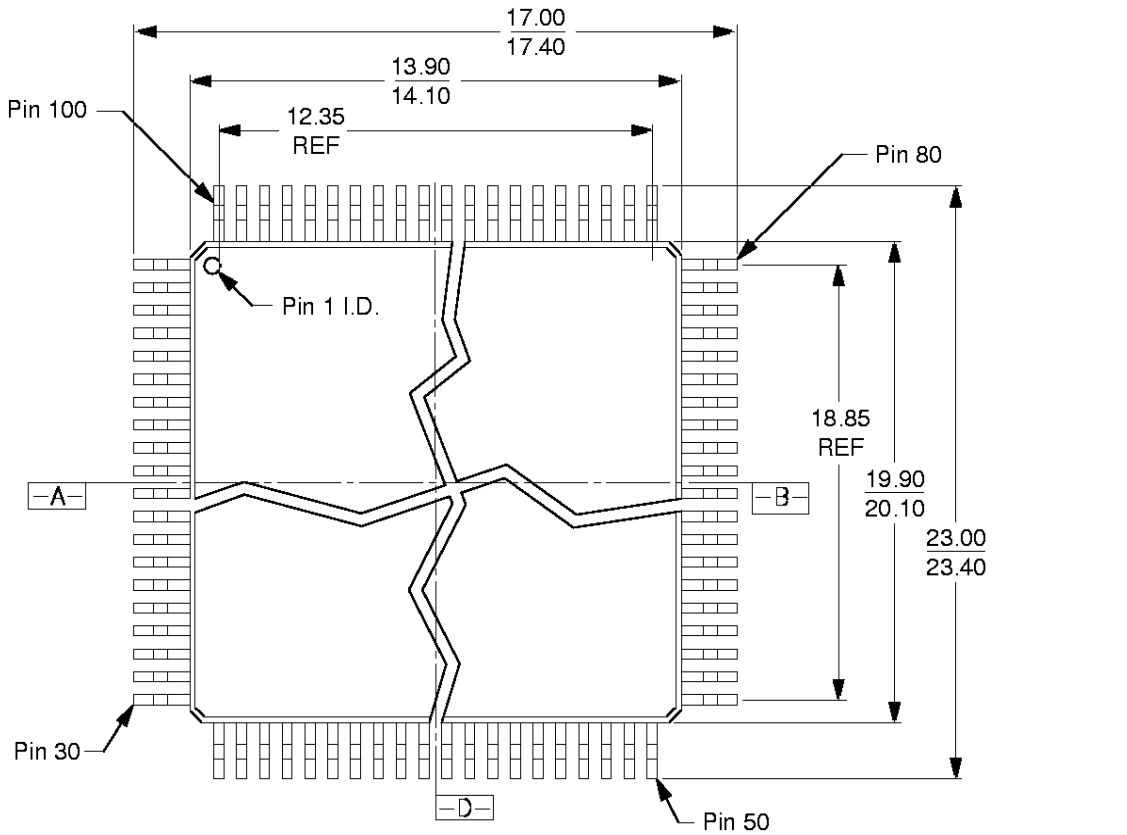

16-038-PQR-1_AH
PQR100
DP92
6-20-96 lv

MACH 5 Family

PHYSICAL DIMENSIONS

PQL100

100-Pin Thin Quad Flat Pack; Trimmed and Formed (measured in millimeters)

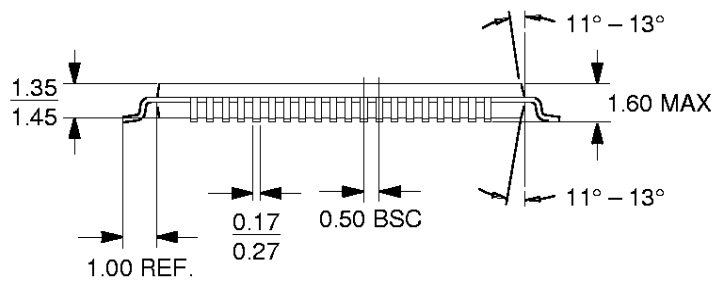
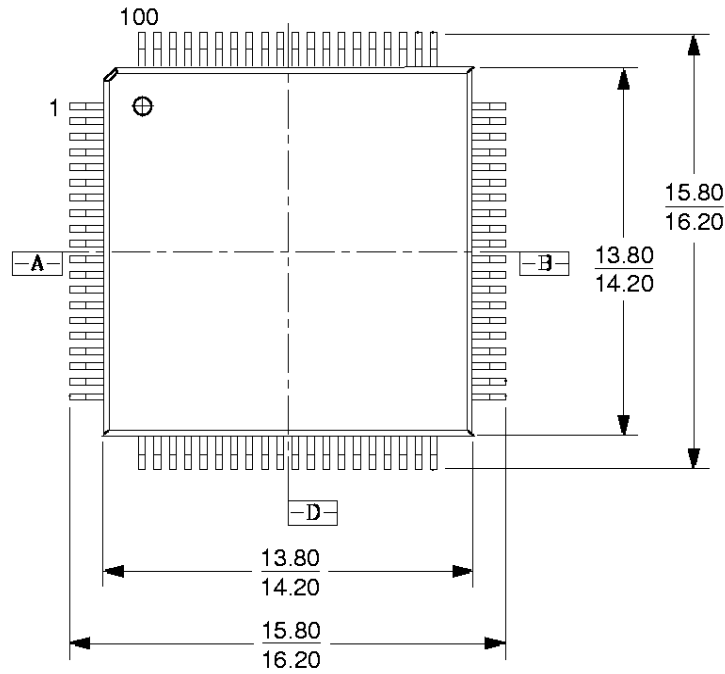

16-038-PQT-2_AI
PQL100
9.3.96 lv

PHYSICAL DIMENSIONS

PQR144

144-Pin Thin Quad Flat Pack; Trimmed and Formed (measured in millimeters)

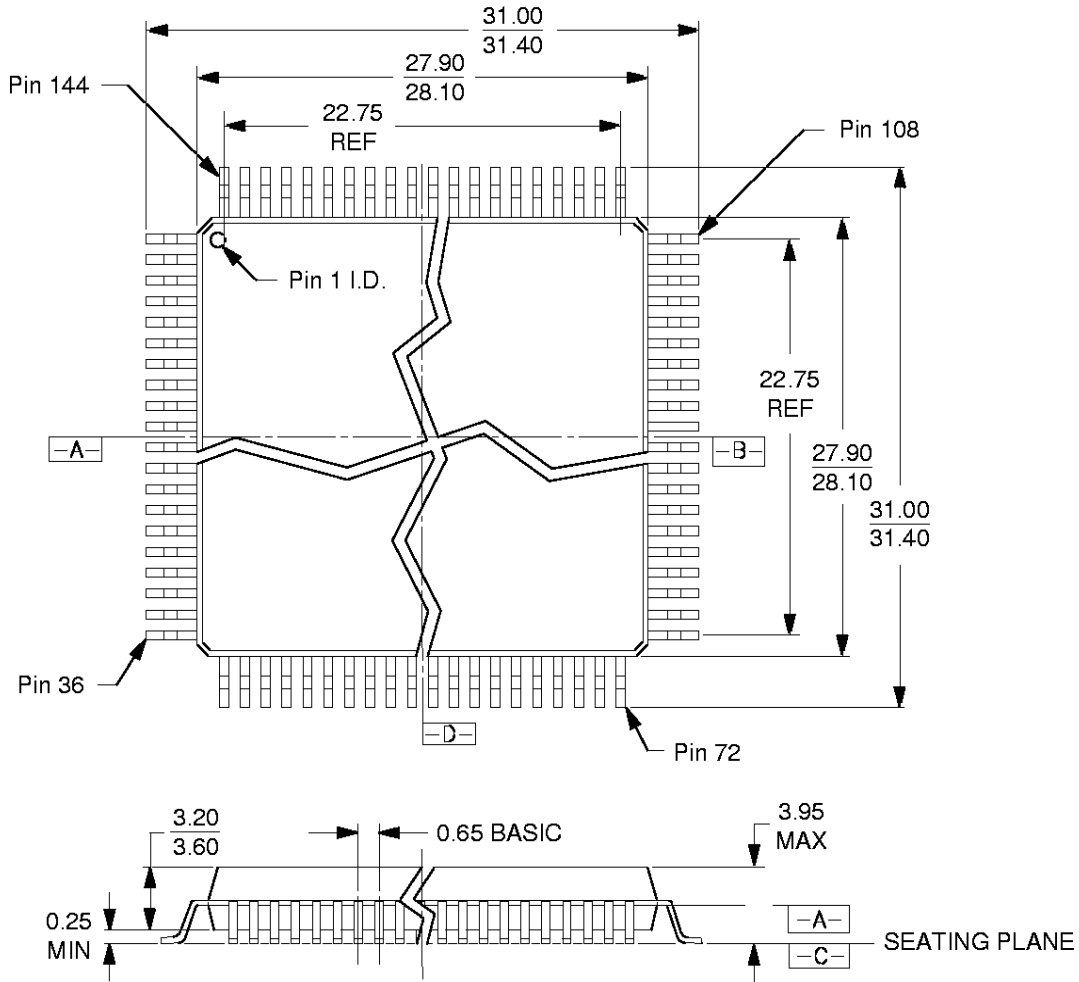

MACH5 Family

16-038-PQR-1_AH
PQR144
EC95

PHYSICAL DIMENSIONS

PQR160

160-Pin Thin Quad Flat Pack; Trimmed and Formed (measured in millimeters)

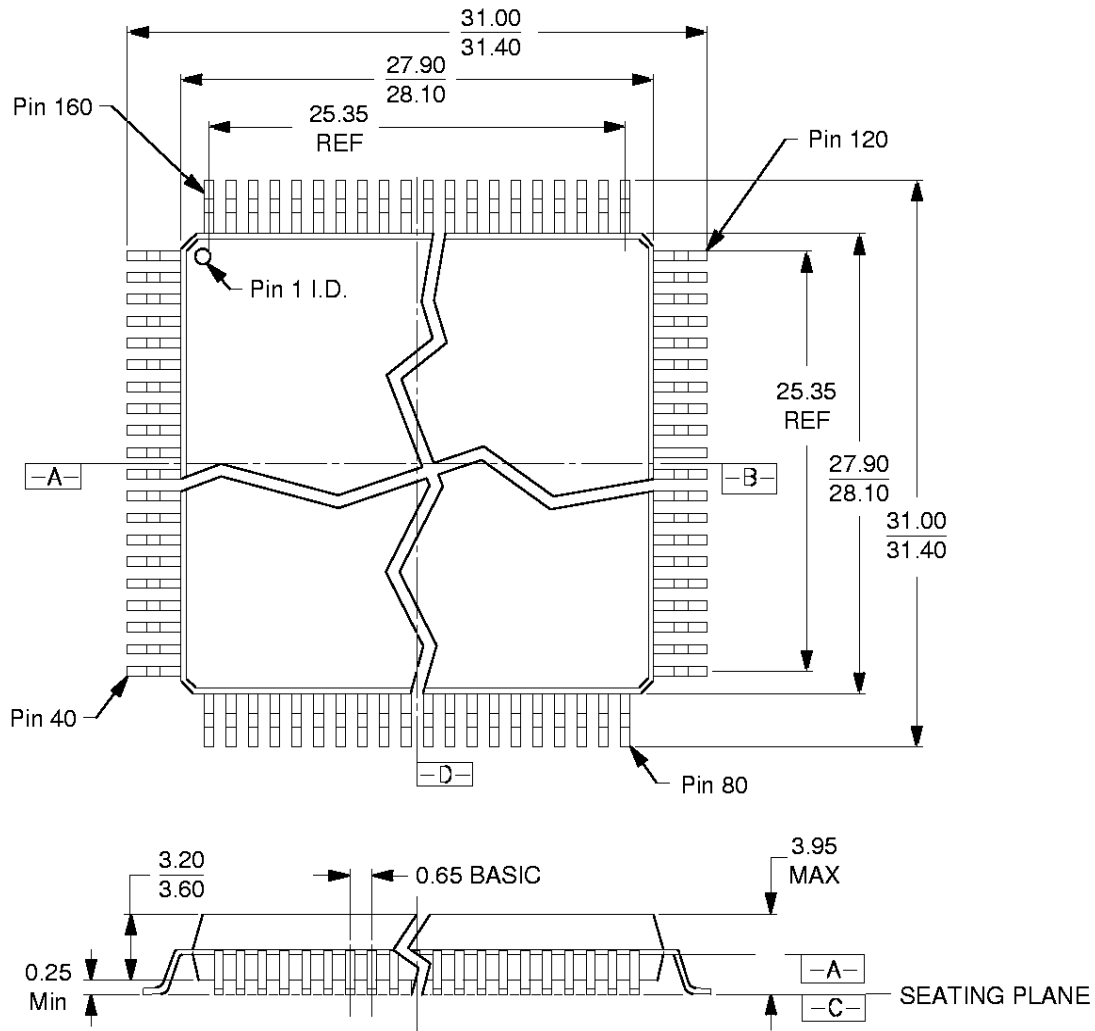

16-038-PQR-1
PQR160
12-22-95 lv

PHYSICAL DIMENSIONS

PQE160

160-Pin Thin Quad Flat Pack; Trimmed and Formed (measured in millimeters)

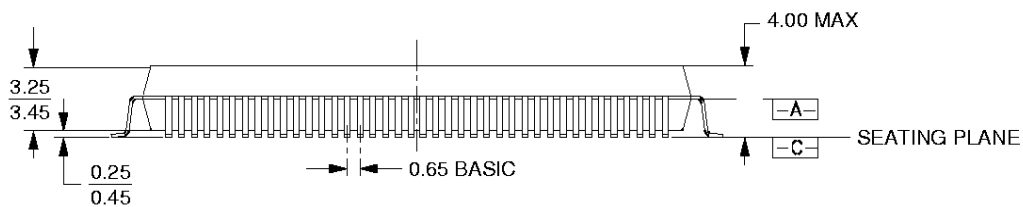
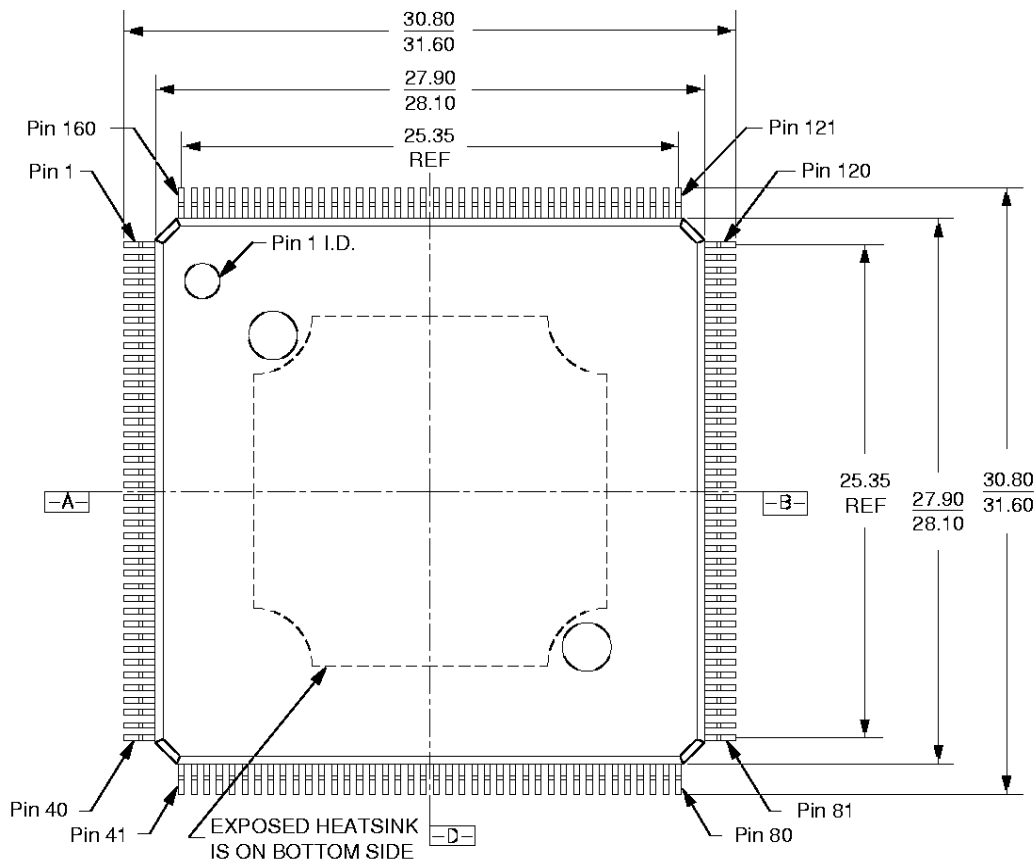

16-038-PQE160-1_AF
DT112
12-13-96 lv

MACH 5 Family

PHYSICAL DIMENSIONS

PRH208

208-Pin Thin Quad Flat Pack; Trimmed and Formed (measured in millimeters)

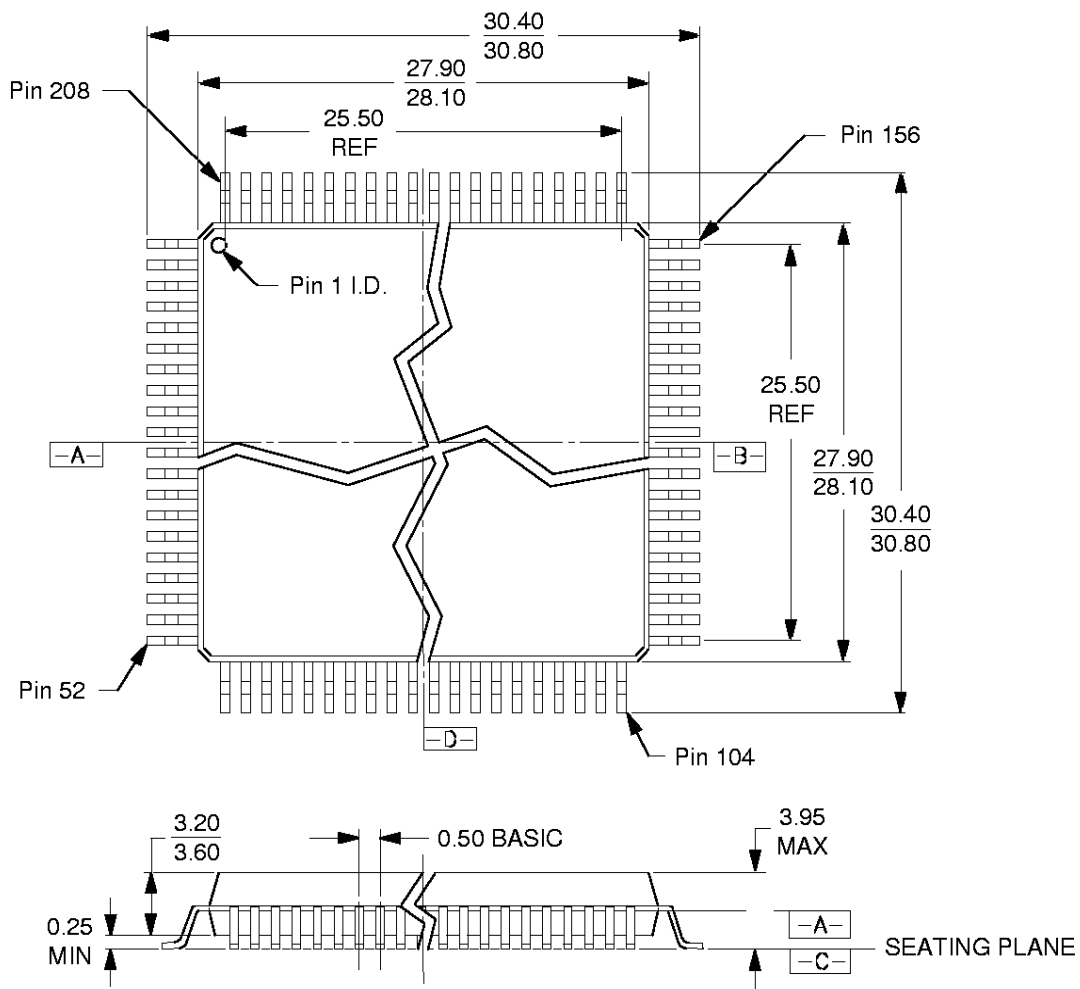

MACH 5 Family

16-038-PQR-1_AH
 PRH208
 EC95
 8-6-97 lv

PHYSICAL DIMENSIONS

PQE240

240-Pin Plastic Quad Flat Pack; Trimmed and Formed (measured in millimeters)

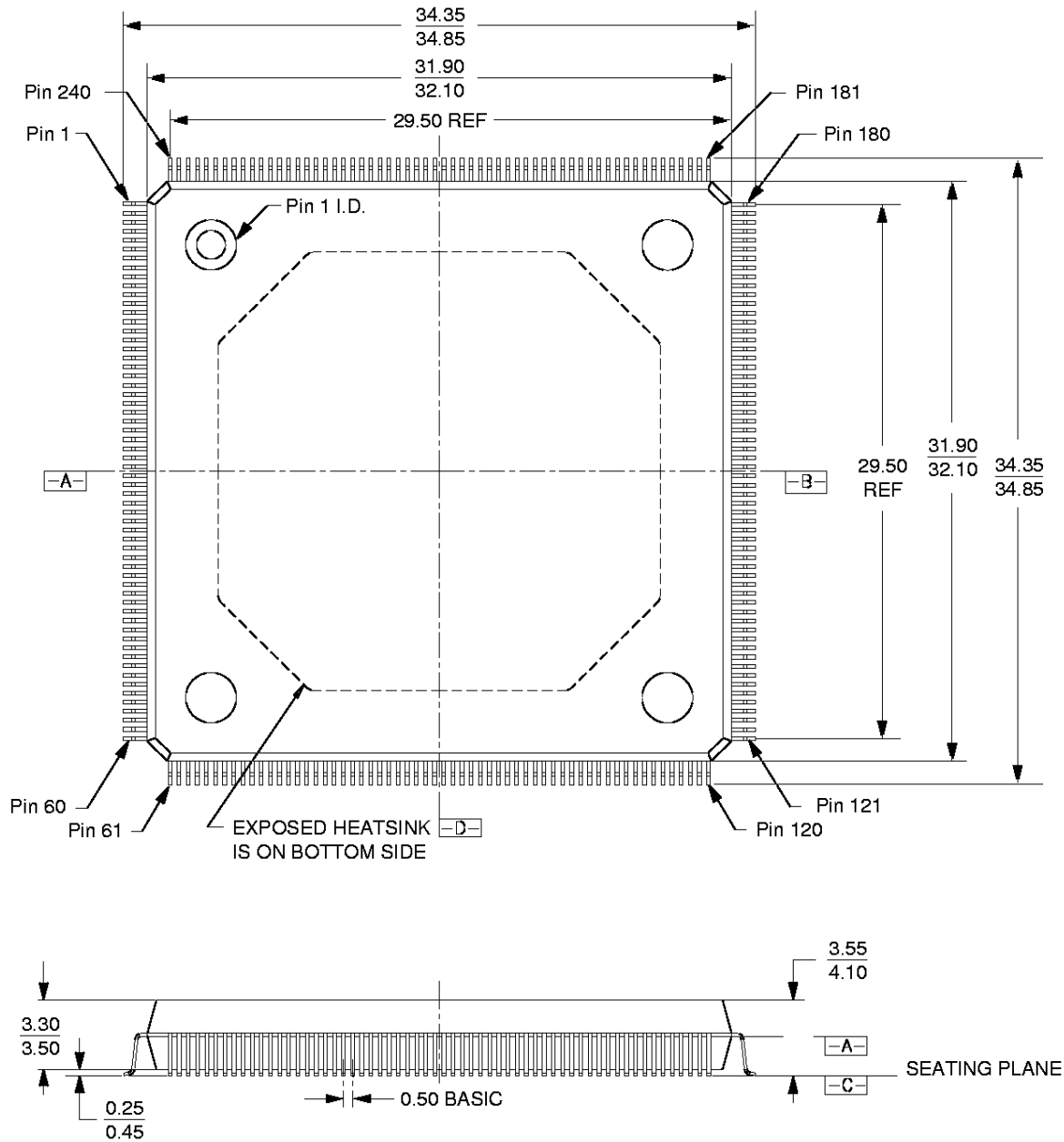

16-038-PQE240-3_AE
DT116
9-18-96 lv

PHYSICAL DIMENSIONS

BGD256

256-Pin Ball Grid Array (measured in millimeters)

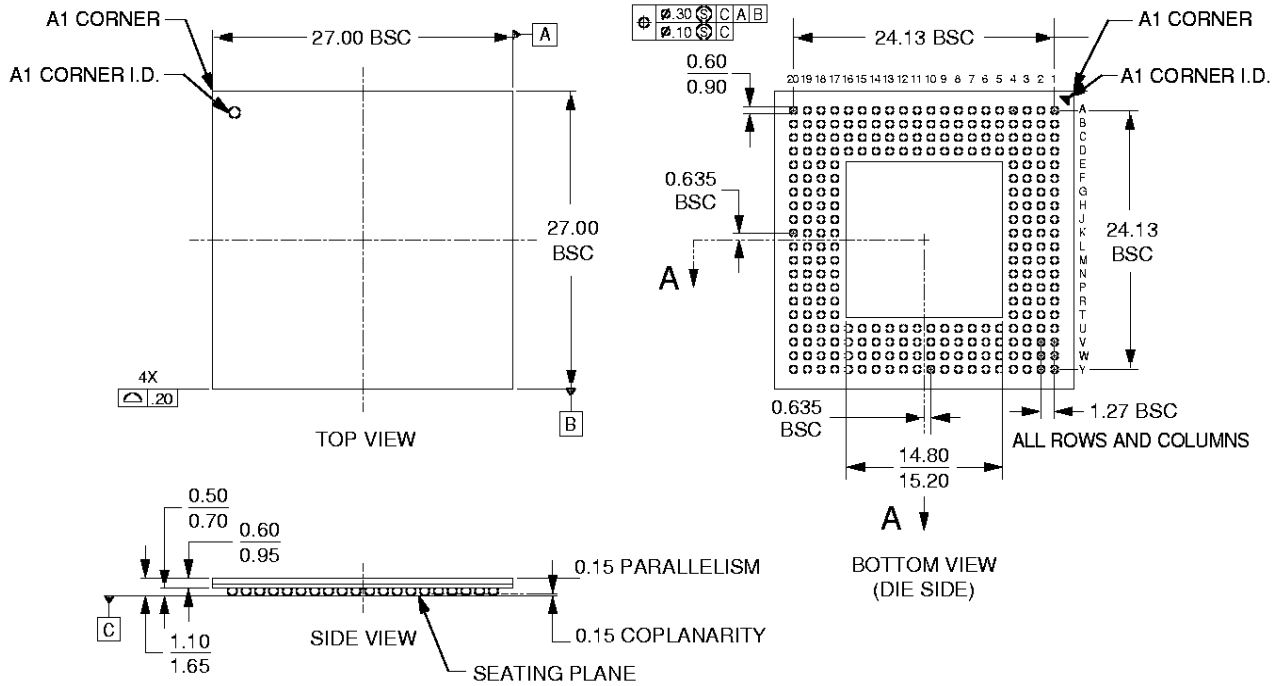

16-038-BGD256-1_AD
DT104
9-19-96 lv

MACH 5 Family

PHYSICAL DIMENSIONS

BGD352

352-Pin Ball Grid Array (measured in millimeters)

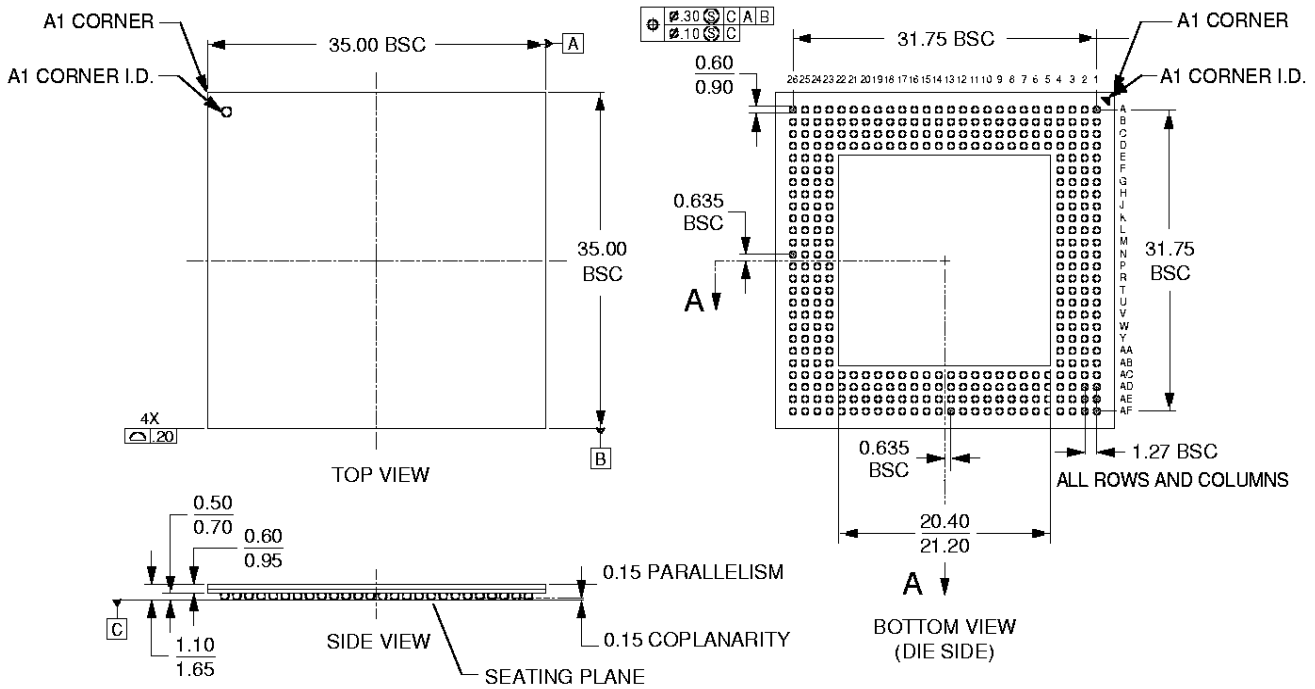

16-038-BGD352-1_AE
DT106
9-19-96 lv

Trademarks

Copyright © 1997 Advanced Micro Devices, Inc. All rights reserved.

AMD, Vantis, the Vantis logo and combinations thereof, and Bus-Friendly are trademarks, MACH, MACHXL and PAL are registered trademarks of Advanced Micro Devices, Inc.

Product names used in this publication are for identification purposes only and may be trademarks of their respective companies.