

MODEL HM76 SERIES

Drum Core Space Efficient

High Performance

Surface Mount Inductors

Inductance Range: 1 to 1,000µH

Rated Current: .1 to 10 Amps

NEW PRODUCT

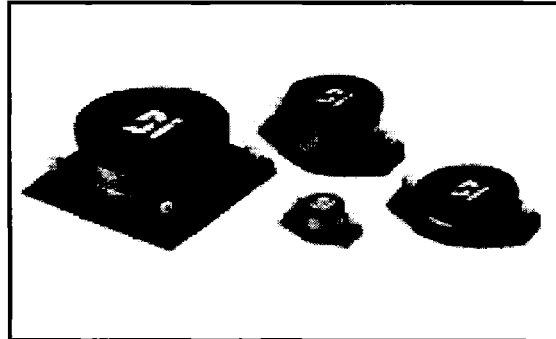

FEATURES

- High performance, high current capacities – Meets today's circuit demands for compact size and current requirements
- Low core loss, excellent for high frequency applications – Designed for the latest clock speeds
- Low profile, designed for machine placement – Easily incorporated into volume production
- Compatible with vapor phase and infrared reflow soldering – No special handling necessary
- Wide range of standard values – Special values available
- 1:1 coupled inductors are available in Model HM76-40xxx – Excellent for circuit isolation (Note 3 & 4)

APPLICATIONS

- Note book computers, PDA's
- DC/DC converters for hand held equipment
- Battery charging circuits
- EMI filters
- Inductor for general purpose
- Ideal for high current, space limited designs

ELECTRICAL

Operating/Storage Temperature Range	-25°C to +80°C
Insulation System	Class B, 130°C
Temperature Rise, Maximum	40°C

Specifications subject to change without notice.

6

BI technologies
CORPORATION

6-69

Model HM76 Series

BITCS00052

SPECIFICATIONS

Part Number (Note 5)	Inductance $\mu\text{H} \pm 20\%$ (Note 1)	DC Resistance @ 25°C Ω Max (Note 3)	Rated Current Amps (Note 2, 4)	Figure
HM76-101R0	1.0	0.03	2.90	1
HM76-101R5	1.5	0.05	2.80	1
HM76-102R2	2.2	0.06	2.40	1
HM76-103R3	3.3	0.09	2.00	1
HM76-104R7	4.7	0.12	1.50	1
HM76-106R8	6.8	0.17	1.30	1
HM76-10100	10	0.22	1.00	1
HM76-10150	15	0.30	0.80	1
HM76-10220	22	0.43	0.70	1
HM76-10330	33	0.69	0.57	1
HM76-10470	47	0.92	0.46	1
HM76-10680	68	1.39	0.37	1
HM76-10101	100	1.98	0.28	1
HM76-10151	150	3.08	0.22	1
HM76-10221	220	4.47	0.18	1
HM76-10331	330	6.90	0.15	1
HM76-10471	470	11.55	0.12	1
HM76-20100	10	0.07	2.00	1
HM76-20150	15	0.09	1.50	1
HM76-20220	22	0.15	1.30	1
HM76-20330	33	0.21	1.10	1
HM76-20470	47	0.31	0.80	1
HM76-20680	68	0.42	0.70	1
HM76-20101	100	0.58	0.60	1
HM76-20151	150	0.89	0.50	1
HM76-20221	220	1.30	0.40	1
HM76-20331	330	2.00	0.30	1
HM76-20471	470	2.50	0.20	1
HM76-20681	680	3.50	0.10	1
HM76-20102	1,000	6.00	0.05	1
HM76-301R0	1.0	0.01	8.50	1
HM76-301R5	1.5	0.01	7.90	1
HM76-302R2	2.2	0.02	7.40	1
HM76-303R3	3.3	0.02	6.60	1

- Notes: 1. Inductance measured at 100KHz, 0.1 Vrms, without DC current.
 2. Rated DC current at which inductance will be decreased by 10% from its initial value or the DC current at which $\Delta T = 40^\circ\text{C}$, whichever is smaller.
 3. Resistance measured with both windings conducted in parallel (case size 40 only).
 4. Rated current will be decreased by 50% when parts are connected as coupled inductors.
 5. Part numbers which appear in bold print are standard items and generally available from factory stock.

SPECIFICATIONS (CONT'D)

Part Number (Note 5)	Inductance $\mu\text{H} \pm 20\%$ (Note 1)	DC Resistance @ 25°C Ω Max (Note 3)	Rated Current Amps (Note 2, 4)	Figure
HM76-304R7	4.7	0.02	6.00	1
HM76-306R8	6.8	0.03	5.20	1
HM76-308R2	8.2	0.03	5.00	1
HM76-30100	10	0.04	4.60	1
HM76-30150	15	0.05	3.70	1
HM76-30220	22	0.07	3.10	1
HM76-30330	33	0.11	2.50	1
HM76-30470	47	0.16	2.00	1
HM76-30680	68	0.20	1.80	1
HM76-30820	82	0.24	1.58	1
HM76-30101	100	0.30	1.50	1
HM76-30151	150	0.44	1.20	1
HM76-30221	220	0.64	1.00	1
HM76-30331	330	1.00	0.80	1
HM76-30471	470	1.50	0.50	1
HM76-30681	680	2.20	0.40	1
HM76-30102	1,000	3.15	0.30	1
HM76-403R3	3.3	0.01	9.80	2
HM76-404R7	4.7	0.01	9.30	2
HM76-406R8	6.8	0.02	7.70	2
HM76-408R2	8.2	0.02	7.00	2
HM76-40100	10	0.02	6.50	2
HM76-40150	15	0.03	5.30	2
HM76-40220	22	0.04	4.40	2
HM76-40330	33	0.06	3.50	2
HM76-40470	47	0.07	3.00	2
HM76-40680	68	0.11	2.50	2
HM76-40820	82	0.12	2.20	2
HM76-40101	100	0.15	2.00	2
HM76-40151	150	0.22	1.70	2
HM76-40221	220	0.33	1.30	2
HM76-40331	330	0.45	1.10	2
HM76-40471	470	0.70	0.93	2
HM76-40681	680	1.00	0.78	2
HM76-40102	1,000	1.45	0.65	2

- Notes: 1. Inductance measured at 100KHz, 0.1 Vrms, without DC current.
 2. Rated DC current at which inductance will be decreased by 10% from its initial value or the DC current at which $\Delta T = 40^\circ\text{C}$, whichever is smaller.
 3. Resistance measured with both windings conducted in parallel (case size 40 only).
 4. Rated current will be decreased by 50% when parts are connected as coupled inductors.
 5. Part numbers which appear in bold print are standard items and generally available from factory stock.

OUTLINE DIMENSIONS/RECOMMENDED PCB LAYOUT (Inch/mm)

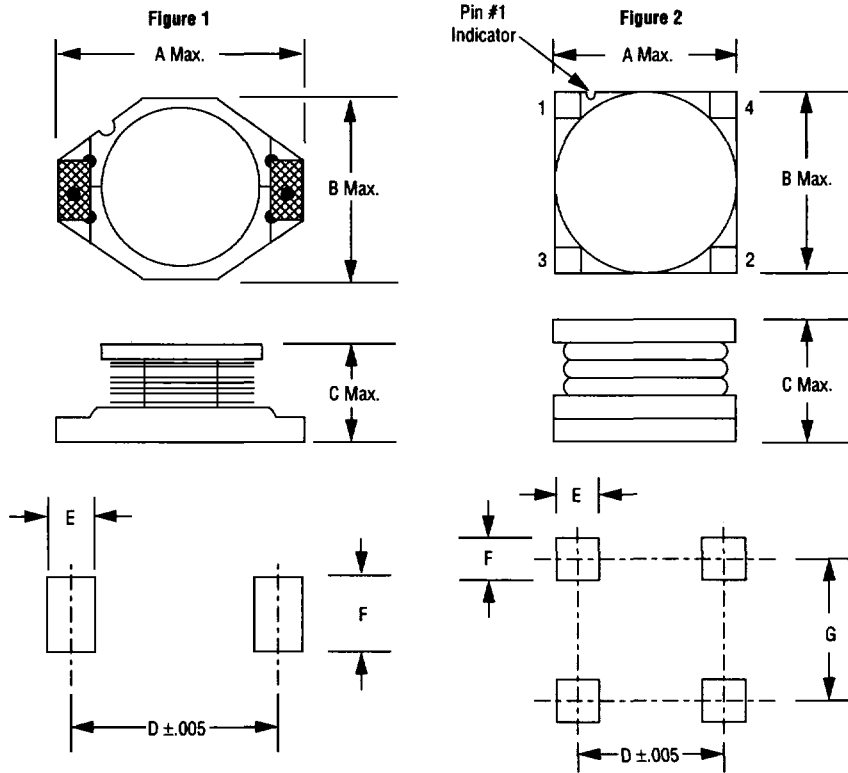

Case Size	Fig.	A	B	C	D	E	F	G
10	1	.279	.188	.127	.218	.059	.10	-
		7.10	4.78	3.23	5.54	1.50	2.54	-
20	1	.530	.370	.137	.404	.120	.135	-
		13.46	9.40	3.50	10.26	3.05	3.43	-
30	1	.530	.370	.232	.404	.120	.135	-
		13.46	9.40	5.90	10.26	3.05	3.43	-
40	2	.634	.622	.284	.520	.157	.138	.466
		16.10	15.80	7.21	13.21	4.00	3.50	11.84

SCHEMATICS

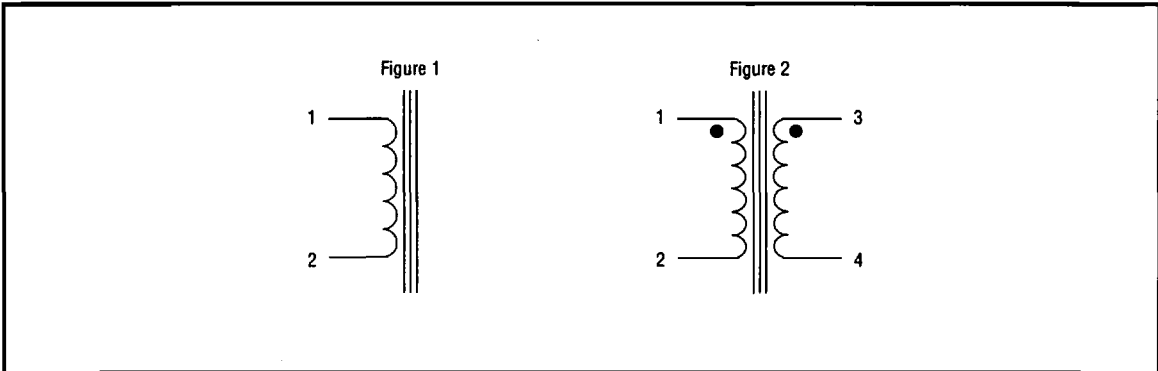

PACKAGING

Standard: Embossed Tape & Reel

Reel: Diameter	=	13"
Capacity, Units: Case Size 10	=	2,000
20	=	1,000
30	=	500
40	=	200

ORDERING INFORMATION

