

**S29GL-A MirrorBit™ Flash Family**  
**S29GL064A, S29GL032A, and S29GL016A**  
**64 Megabit, 32 Megabit, and 16 Megabit**  
**3.0-Volt only Page Mode Flash Memory**  
**Featuring 200 nm MirrorBit Process Technology**



*Data Sheet*

**PRELIMINARY**

**Notice to Readers:** This document indicates states the current technical specifications regarding the Spansion product(s) described herein. The Preliminary status of this document indicates that a product qualification has been completed, and that initial production has begun. Due to the phases of the manufacturing process that require maintaining efficiency and quality, this document may be revised by subsequent versions or modifications due to changes in technical specifications.

## Notice On Data Sheet Designations

Spansion LLC issues data sheets with Advance Information or Preliminary designations to advise readers of product information or intended specifications throughout the product life cycle, including development, qualification, initial production, and full production. In all cases, however, readers are encouraged to verify that they have the latest information before finalizing their design. The following descriptions of Spansion data sheet designations are presented here to highlight their presence and definitions.

### Advance Information

The Advance Information designation indicates that Spansion LLC is developing one or more specific products, but has not committed any design to production. Information presented in a document with this designation is likely to change, and in some cases, development on the product may discontinue. Spansion LLC therefore places the following conditions upon Advance Information content:

“This document contains information on one or more products under development at Spansion LLC. The information is intended to help you evaluate this product. Do not design in this product without contacting the factory. Spansion LLC reserves the right to change or discontinue work on this proposed product without notice.”

### Preliminary

The Preliminary designation indicates that the product development has progressed such that a commitment to production has taken place. This designation covers several aspects of the product life cycle, including product qualification, initial production, and the subsequent phases in the manufacturing process that occur before full production is achieved. Changes to the technical specifications presented in a Preliminary document should be expected while keeping these aspects of production under consideration. Spansion places the following conditions upon Preliminary content:

“This document states the current technical specifications regarding the Spansion product(s) described herein. The Preliminary status of this document indicates that product qualification has been completed, and that initial production has begun. Due to the phases of the manufacturing process that require maintaining efficiency and quality, this document may be revised by subsequent versions or modifications due to changes in technical specifications.”

### Combination

Some data sheets will contain a combination of products with different designations (Advance Information, Preliminary, or Full Production). This type of document will distinguish these products and their designations wherever necessary, typically on the first page, the ordering information page, and pages with DC Characteristics table and AC Erase and Program table (in the table notes). The disclaimer on the first page refers the reader to the notice on this page.

### Full Production (No Designation on Document)

When a product has been in production for a period of time such that no changes or only nominal changes are expected, the Preliminary designation is removed from the data sheet. Nominal changes may include those affecting the number of ordering part numbers available, such as the addition or deletion of a speed option, temperature range, package type, or  $V_{IO}$  range. Changes may also include those needed to clarify a description or to correct a typographical error or incorrect specification. Spansion LLC applies the following conditions to documents in this category:

“This document states the current technical specifications regarding the Spansion product(s) described herein. Spansion LLC deems the products to have been in sufficient production volume such that subsequent versions of this document are not expected to change. However, typographical or specification corrections, or modifications to the valid combinations offered may occur.”

Questions regarding these document designations may be directed to your local AMD or Fujitsu sales office.

# S29GL-A MirrorBit™ Flash Family

S29GL064A, S29GL032A, and S29GL016A

64 Megabit, 32 Megabit, and 16 Megabit

3.0-Volt only Page Mode Flash Memory

Featuring 200 nm MirrorBit Process Technology



Data Sheet

PRELIMINARY

## Distinctive Characteristics

### Architectural Advantages

- **Single power supply operation**
  - 3-Volt read, erase, and program operations
- **Manufactured on 200 nm MirrorBit process technology**
- **Secured Silicon Sector region**
  - 128-word/256-byte sector for permanent, secure identification through an 8-word/16-byte random Electronic Serial Number, accessible through a command sequence
  - May be programmed and locked at the factory or by the customer
- **Flexible sector architecture**
  - 64Mb (uniform sector models): 128 32 Kword (64 KB) sectors
  - 64 Mb (boot sector models): 127 32 Kword (64 KB) sectors + 8 4Kword (8KB) boot sectors
  - 32 Mb (uniform sector models): 64 32Kword (64 KB) sectors
  - 32 Mb (boot sector models): 63 32Kword (64 KB) sectors + 8 4Kword (8KB) boot sectors
  - 16 Mb (boot sector models): 31 31Kword (64 KB) sectors + 8 4Kword (8 KB) boot sectors
- **Compatibility with JEDEC standards**
  - Provides pinout and software compatibility for single-power supply flash, and superior inadvertent write protection
- **100,000 erase cycles typical per sector**
- **20-year data retention typical**

### Performance Characteristics

- **High performance**
  - 90 ns access time
  - 4-word/8-byte page read buffer
  - 25 ns page read times
  - 16-word/32-byte write buffer which reduces overall programming time for multiple-word updates

- **Low power consumption (typical values at 3.0 V, 5 MHz)**
  - 18 mA typical active read current
  - 50 mA typical erase/program current
  - 1  $\mu$ A typical standby mode current
- **Package options**
  - 48-pin TSOP
  - 56-pin TSOP
  - 64-ball Fortified BGA
  - 48-ball fine-pitch BGA
  - 56-ball fine pitch BGA (MCP-compatible for cellular handsets)

### Software & Hardware Features

- **Software features**
  - Program Suspend & Resume: read other sectors before programming operation is completed
  - Erase Suspend & Resume: read/program other sectors before an erase operation is completed
  - Data# polling & toggle bits provide status
  - CFI (Common Flash Interface) compliant: allows host system to identify and accommodate multiple flash devices
  - Unlock Bypass Program command reduces overall multiple-word programming time
- **Hardware features**
  - Sector Group Protection: hardware-level method of preventing write operations within a sector group
  - Temporary Sector Unprotect:  $V_{ID}$ -level method of charging code in locked sectors
  - WP#/ACC input accelerates programming time (when high voltage is applied) for greater throughput during system production. Protects first or last sector regardless of sector protection settings on uniform sector models
  - Hardware reset input (RESET#) resets device
  - Ready/Busy# output (RY/BY#) detects program or erase cycle completion

## General Description

The S29GL-A family of devices are 3.0-Volt single-power Flash memory manufactured using 200 nm MirrorBit technology. The S29GL064A is a 64-Mb device organized as 4,194,304 words or 8,388,608 bytes. The S29GL032A is a 32-Mb device organized as 2,097,152 words or 4,194,304 bytes. The S29GL016A is a 16-Mb device organized as 1,048,576 words or 2,097,152 bytes. Depending on the model number, the devices have an 8-bit wide data bus only, 16-bit wide data bus only, or a 16-bit wide data bus that can also function as an 8-bit wide data bus by using the BYTE# input. The devices can be programmed either in the host system or in standard EPROM programmers.

Access times as fast as 90 ns are available. Note that each access time has a specific operating voltage range ( $V_{CC}$ ) as specified in the [Product Selector Guide](#) and the [Ordering Information–S29GL016A](#), [Ordering Information–S29GL032A](#), and [Ordering Information–S29GL064A](#). Package offerings include 48-pin TSOP, 56-pin TSOP, 48-ball fine-pitch BGA and 64-ball Fortified BGA, depending on model number. Each device has separate chip enable (CE#), write enable (WE#) and output enable (OE#) controls.

Each device requires only a **single 3.0-Volt power supply** for both read and write functions. In addition to a  $V_{CC}$  input, a high-voltage **accelerated program (ACC)** feature provides shorter programming times through increased current on the WP#/ACC input. This feature is intended to facilitate factory throughput during system production, but may also be used in the field if desired.

The device is entirely command set compatible with the **JEDEC single-power-supply Flash standard**. Commands are written to the device using standard microprocessor write timing. Write cycles also internally latch addresses and data needed for the programming and erase operations.

The **sector erase architecture** allows memory sectors to be erased and reprogrammed without affecting the data contents of other sectors. The device is fully erased when shipped from the factory.

Device programming and erasure are initiated through command sequences. Once a program or erase operation begins, the host system need only poll the DQ7 (Data# Polling) or DQ6 (toggle) **status bits** or monitor the **Ready/Busy# (RY/BY#)** output to determine whether the operation is complete. To facilitate programming, an **Unlock Bypass** mode reduces command sequence overhead by requiring only two write cycles to program data instead of four.

**Hardware data protection** measures include a low  $V_{CC}$  detector that automatically inhibits write operations during power transitions. The hardware sector protection feature disables both program and erase operations in any combination of sectors of memory. This can be achieved in-system or via programming equipment.

The **Erase Suspend/Erase Resume** feature allows the host system to pause an erase operation in a given sector to read or program any other sector and then complete the erase operation. The **Program Suspend/Program Resume** feature enables the host system to pause a program operation in a given sector to read any other sector and then complete the program operation.

The **hardware RESET# pin** terminates any operation in progress and resets the device, after which it is then ready for a new operation. The RESET# pin may be tied to the system reset circuitry. A system reset would thus also reset the device, enabling the host system to read boot-up firmware from the Flash memory device.

The device reduces power consumption in the **standby mode** when it detects specific voltage levels on CE# and RESET#, or when addresses are stable for a specified period of time.

The **Write Protect (WP#)** feature protects the first or last sector by asserting a logic low on the WP#/ACC pin or WP# pin, depending on model number. The protected sector is still protected even during accelerated programming.

The **Secured Silicon Sector** provides a 128-word/256-byte area for code or data that can be permanently protected. Once this sector is protected, no further changes within the sector can occur.

Spansion MirrorBit flash technology combines years of Flash memory manufacturing experience to produce the highest levels of quality, reliability and cost effectiveness. The device electrically erases all bits within a sector simultaneously via hot-hole assisted erase. The data is programmed using hot electron injection.

# Table of Contents

<b>Notice On Data Sheet Designations</b> .....	<b>ii</b>	Unprotection Address Table .....	40
<b>Product Selector Guide</b> .....	<b>6</b>	Table 21. S29GL064A (Models R1, R2, R8, R9, W1, W2) Sector Group Protection/Unprotection Addresses .....	40
S29GL064A, S29GL032A, S29GL016A .....	6	Table 22. S29GL064A (Model R3, W3) Top Boot Sector Protection/Unprotection Addresses .....	41
<b>Block Diagram</b> .....	<b>7</b>	Table 23. S29GL064A (Model R4, W4) Bottom Boot Sector Protection/Unprotection Addresses .....	41
<b>Connection Diagrams</b> .....	<b>8</b>	Table 24. S29GL064A (Model R5) Sector Group Protection/Unprotection Addresses .....	42
<b>Pin Descriptions</b> .....	<b>12</b>	Table 25. S29GL064A (Models R6, R7) Sector Group Protection/Unprotection Addresses .....	42
Logic Symbol–S29GL064A (Models R1, R2, R8, R9) .....	12	<b>Temporary Sector Group Unprotect</b> .....	<b>43</b>
Logic Symbol–S29GL064A (Model R5) .....	13	Figure 1. Temporary Sector Group Unprotect Operation .....	43
Logic Symbol–S29GL064A (Models R6, R7) .....	13	Figure 2. In-System Sector Group Protect/Unprotect Algorithms .....	44
Logic Symbol–S29GL064A (Models W1, W2, WE, and W4) .....	14	<b>Secured Silicon Sector Flash Memory Region</b> .....	<b>45</b>
Logic Symbol–S29GL032A (Models R1, R2) .....	14	<b>Write Protect (WP#)</b> .....	<b>46</b>
Logic Symbol–S29GL032A (Models R3, R4) .....	14	<b>Hardware Data Protection</b> .....	<b>46</b>
Logic Symbol–S29GL032A (Models W1,W2,W3, and W4) .....	15	Table 26. CFI Query Identification String .....	48
Logic Symbol–S29GL016A (Models R1, R2) .....	15	Table 27. System Interface String .....	48
Logic Symbol–S29GL016A (Models W3,W4) .....	15	Table 29. Primary Vendor-Specific Extended Query .....	49
<b>Ordering Information–S29GL016A</b> .....	<b>16</b>	<b>Command Definitions</b> .....	<b>50</b>
S29GL016A Standard Products .....	16	Reading Array Data .....	50
Table 1. S29GL016A Ordering Options .....	16	Reset Command .....	50
<b>Ordering Information–S29GL032A</b> .....	<b>17</b>	Autoselect Command Sequence .....	51
S29GL032A Standard Products .....	17	Enter/Exit Secured Silicon Sector Command Sequence .....	51
Table 2. S29GL032A Ordering Options .....	17	Figure 3. Write Buffer Programming Operation.....	55
<b>Ordering Information–S29GL064A</b> .....	<b>18</b>	Figure 4. Program Operation .....	56
S29GL064A Standard Products .....	18	<b>Program Suspend/Program Resume Command Sequence</b> .....	<b>56</b>
Table 3. S29GL064A Valid Combinations .....	18	Figure 5. Program Suspend/Program Resume .....	57
<b>Device Bus Operations</b> .....	<b>19</b>	<b>Chip Erase Command Sequence</b> .....	<b>57</b>
Table 4. Device Bus Operations .....	19	Figure 6. Erase Operation .....	59
Word/Byte Configuration .....	20	<b>Erase Suspend/Erase Resume Commands</b> .....	<b>59</b>
Requirements for Reading Array Data .....	20	<b>Command Definitions</b> .....	<b>61</b>
Writing Commands/Command Sequences .....	20	Table 30. Command Definitions (x16 Mode, BYTE# = V <sub>IH</sub> ) .....	61
Standby Mode .....	21	Table 31. Command Definitions (x8 Mode, BYTE# = V <sub>IL</sub> ) .....	62
Automatic Sleep Mode .....	22	<b>Write Operation Status</b> .....	<b>63</b>
RESET#: Hardware Reset Pin .....	22	<b>DQ7: Data# Polling</b> .....	<b>63</b>
Output Disable Mode .....	22	Figure 7. Data# Polling Algorithm .....	64
Table 5. S29GL016A (Model R1, W1) Top Boot Sector Addresses .....	23	<b>RY/BY#: Ready/Busy#</b> .....	<b>64</b>
Table 6. S29GL016A (Model R2, W2) Bottom Boot Sector Addresses .....	24	<b>DQ6: Toggle Bit I</b> .....	<b>65</b>
Table 7. S29GL032A (Models R1, R2, W1, W2) Sector Addresses .....	25	Figure 8. Toggle Bit Algorithm .....	66
Table 8. S29GL032A (Model R3, W3) Top Boot Sector Addresses .....	26	<b>DQ2: Toggle Bit II</b> .....	<b>67</b>
Table 9. S29GL032A (Model R4, W4) Bottom Boot Sector Addresses .....	27	<b>Reading Toggle Bits DQ6/DQ2</b> .....	<b>67</b>
Table 10. S29GL064A (Models R1, R2, R8, R9, W1, W2) Sector Addresses .....	28	<b>DQ5: Exceeded Timing Limits</b> .....	<b>67</b>
Table 11. S29GL064A (Model R3, W3) Top Boot Sector Addresses .....	30	<b>DQ3: Sector Erase Timer</b> .....	<b>68</b>
Table 12. S29GL064A (Model R4, W4) Bottom Boot Sector Addresses .....	32	<b>DQI: Write-to-Buffer Abort</b> .....	<b>68</b>
Table 13. S29GL064A (Model R5) Sector Addresses .....	34	Table 32. Write Operation Status .....	68
Table 14. S29GL064A (Models R6, R7) Sector Addresses .....	36	<b>Absolute Maximum Ratings</b> .....	<b>69</b>
<b>Autoselect Mode</b> .....	<b>37</b>	Figure 9. Maximum Negative Overshoot Waveform .....	69
Table 15. Autoselect Codes, (High Voltage Method) .....	38	Figure 10. Maximum Positive Overshoot Waveform .....	69
<b>Sector Group Protection and Unprotection</b> .....	<b>38</b>	<b>Operating Ranges</b> .....	<b>70</b>
Table 16. S29GL016A (Model R1, O1, W1) Sector Group Protection/Unprotection Addresses .....	39	<b>DC Characteristics</b> .....	<b>71</b>
Table 17. S29GL016A (Model R2, O2, W2) Sector Group Protection/Unprotection Addresses .....	39	CMOS Compatible .....	71
Table 18. S29GL032A (Models R1, R2, W1, W2) Sector Group Protection/Unprotection Addresses .....	39	<b>Test Conditions</b> .....	<b>72</b>
Table 19. S29GL032A (Model R3, W3) Sector Group Protection/Unprotection Address Table .....	40	Figure 11. Test Setup .....	72
Table 20. S29GL032A (Model R4, W4) Sector Group Protection/Unprotection Address Table .....	40	Table 33. Test Specifications .....	72
		Figure 12. Input Waveforms and Measurement Levels .....	72
		<b>AC Characteristics</b> .....	<b>73</b>
		Table 34. Read-Only Operations-S29GL064A Only .....	73
		Table 35. Read-Only Operations-S29GL032A Only .....	73
		Table 36. Read-Only Operation-S29GL016A Only .....	74

Figure 13. Read Operation Timings .....	74	tion Timings.....	86
Figure 14. Page Read Timings .....	75	<b>Erase And Programming Performance .....</b>	<b>87</b>
Table 37. Hardware Reset (RESET#) .....	75	Table 45. TSOP Pin and BGA Package Capacitance .....	87
Figure 15. Reset Timings .....	75	<b>Physical Dimensions .....</b>	<b>88</b>
Table 38. Erase and Program Operations-S29GL064A .....	76	TS048—48-Pin Standard Thin Small Outline Package (TSOP) .....	88
Table 39. Erase and Program Operations-S29GL032A Only .....	77	TS056—56-Pin Standard Thin Small Outline Package (TSOP) .....	89
Table 40. Erase and Program Operations-S29GL016A Only .....	78	LAA064—64-Ball Fortified Ball Grid Array (BGA) .....	90
Figure 16. Program Operation Timings .....	79	VBN048—48-Ball Fine-pitch Ball Grid Array (BGA)	
Figure 17. Accelerated Program Timing Diagram.....	79	10x 6 mm Package .....	91
Figure 18. Chip/Sector Erase Operation Timings .....	80	VBK048—Ball Fine-pitch Ball Grid Array (BGA)	
Figure 19. Data# Polling Timings (During Embedded Algorithms) 80		8.15x 6.15 mm Package .....	92
Figure 20. Toggle Bit Timings (During Embedded Algorithms).....	81	VBU056—Ball Fine-pitch Ball Grid Array (BGA) 9 x 7 mm Package ..	93
Figure 21. DQ2 vs. DQ6 .....	81	<b>Revision Summary .....</b>	<b>94</b>
Table 41. Temporary Sector Unprotect .....	81	Revision A (October 13, 2004) .....	94
Figure 22. Temporary Sector Group Unprotect Timing Diagram ..	82	Revision A1 (December 17, 2004) .....	94
Figure 23. Sector Group Protect and Unprotect Timing Diagram..	82	Revision A2 (January 28, 2005) .....	94
Table 42. Alternate CE# Controlled Erase and Program Operations-		Revision A3 (April 22, 2005) .....	94
S29GL064A .....	83	Revision A4 (July 29, 2005) .....	94
Table 43. Alternate CE# Controlled Erase and Program Operations-		Revision A5 (January 4, 2006) .....	94
S29GL032A .....	84		
Table 44. Alternate CE# Controlled Erase and Program Operations-			
S29GL016A .....	85		
Figure 24. Alternate CE# Controlled Write (Erase/Program) Opera-			

## Product Selector Guide

### S29GL064A, S29GL032A, S29GL016A

Part Number	S29GL064A			S29GL032A			S29GL016A	
	90	10	11	90	10	11	90	10
Speed Option	90	10	11	90	10	11	90	10
Max. Access Time (ns)	90	100	110	90	100	110	90	100
Max. CE# Access Time (ns)	90	100	110	90	100	110	90	100
Max. Page Access Time (ns)	25	30	30	25	30	30	25	30
Max. OE# Access Time (ns)	25	30	30	25	30	30	25	30



## Block Diagram

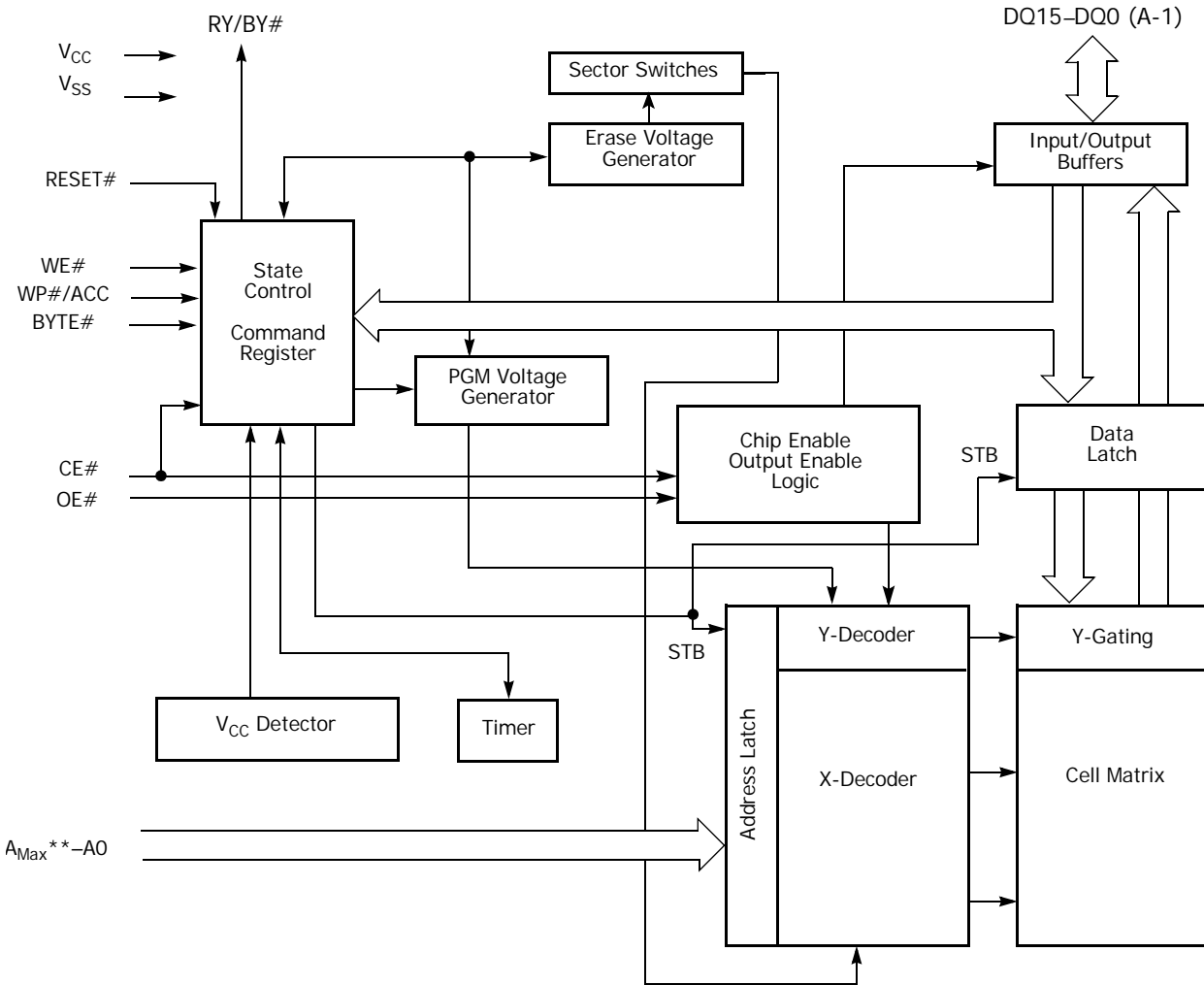

**Note:**

- \*\* $A_{MAX}$  GL064A = A21.
- \*\* $A_{MAX}$  GL032A = A20.
- \*\* $A_{MAX}$  GL016A = A19.

# Connection Diagrams

## Special Package Handling Instructions

Special handling is required for Flash Memory products in molded packages (TSOP and BGA). The package and/or data integrity may be compromised if the package body is exposed to temperatures above 150°C for prolonged periods of time.

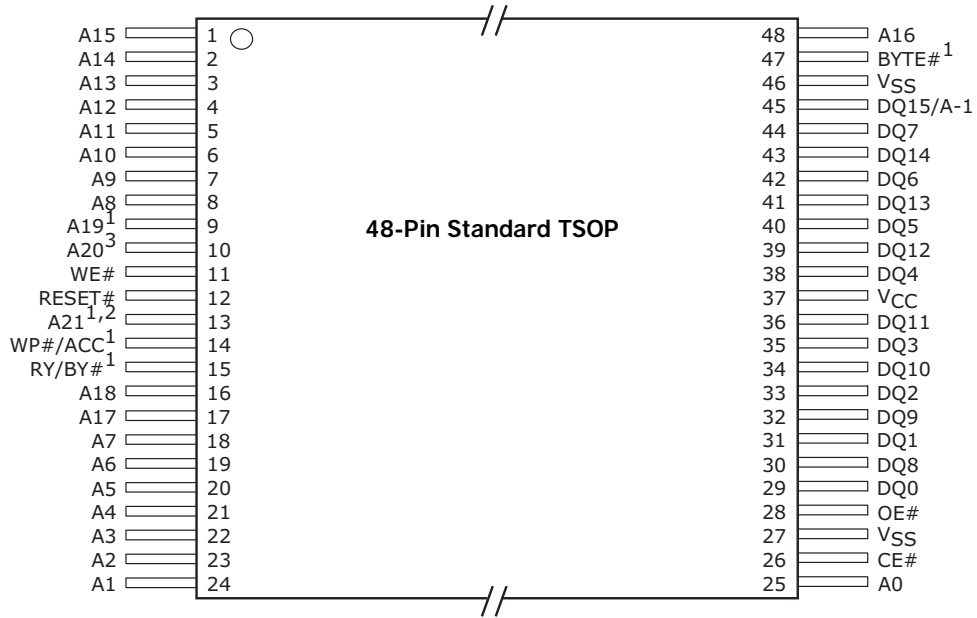

**Notes:**

1. Pin 9 is A21, Pin 13 is ACC, Pin 14 is WP#, Pin 15 is A19, and Pin 47 is V<sub>IO</sub> on S29GL064A (models R6, R7).
2. Pin 13 is NC on S29GL032A, and S29GL016A.
3. Pin 10 is NC on S29GL016A.

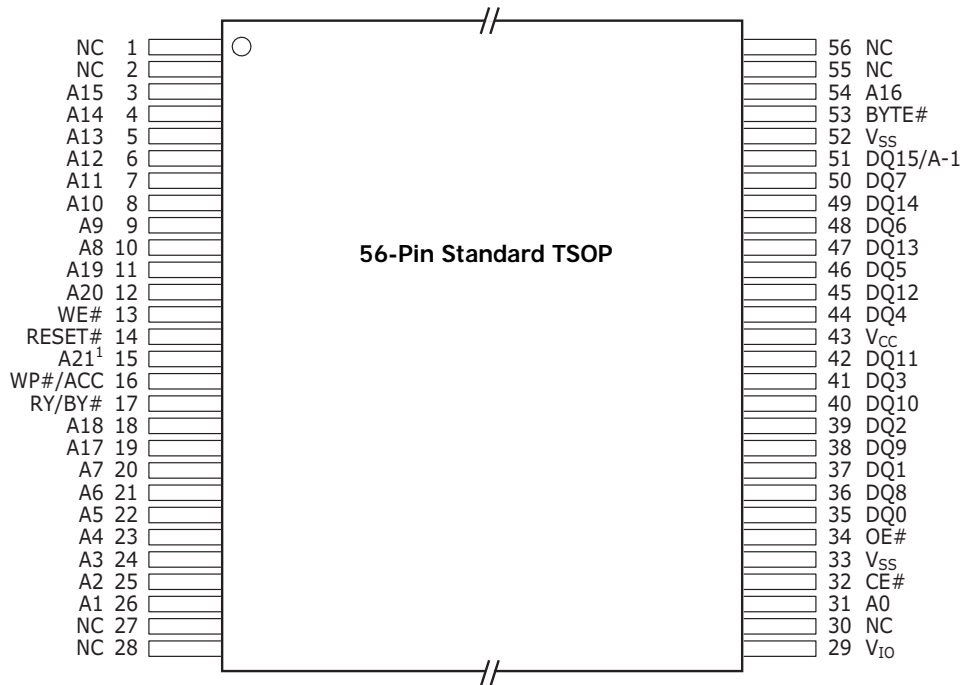

**Note:** Pin 15 is NC on S29GL032A.

**64-ball Fortified BGA**  
Top View, Balls Facing Down

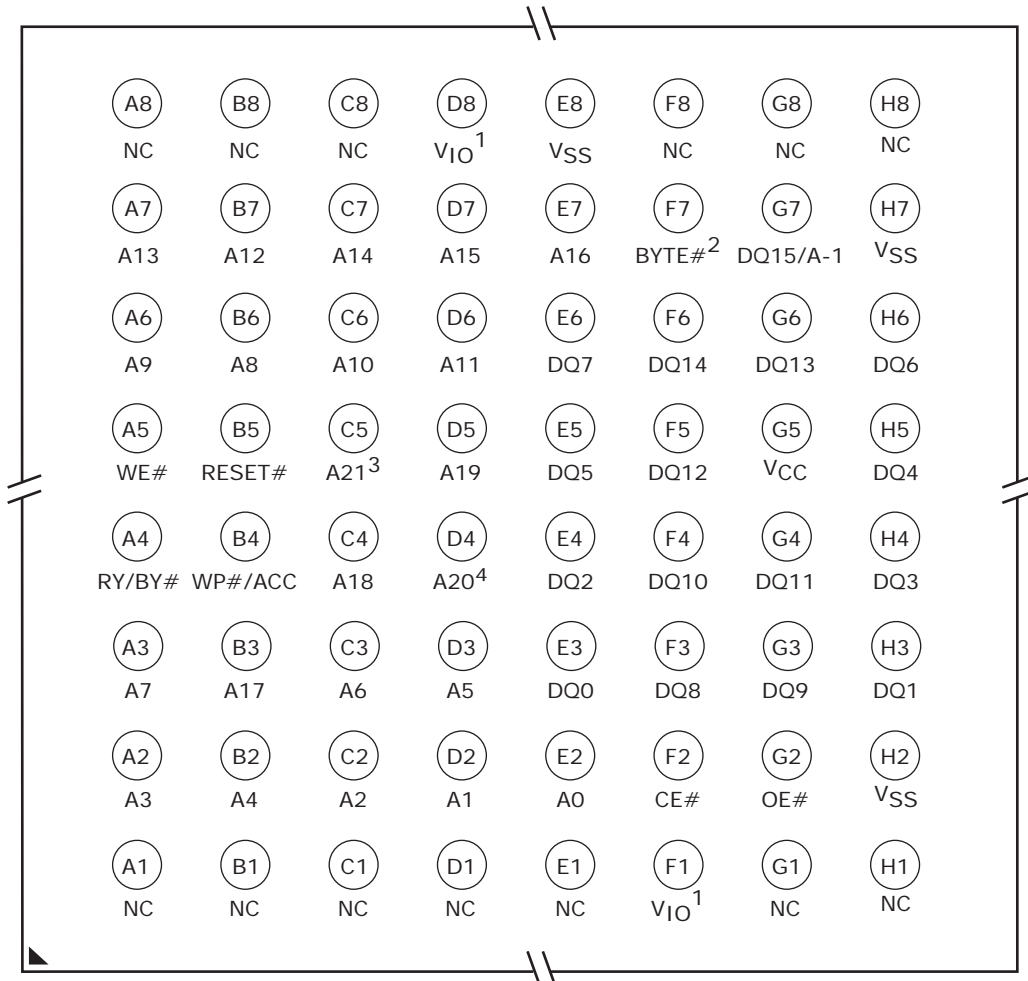

**Notes:**

1. Ball D8 and Ball F1 are NC on S29GL064A (models R3, R4).
2. Ball F7 is NC on S29GL064A (model R5).
3. Ball C5 is NC on S29GL032A and S29GL016A.
4. Ball D4 is NC on S29GL016A.

**56-Ball Fine-Pitch Ball Grid Array**  
Top View, Balls Facing Down

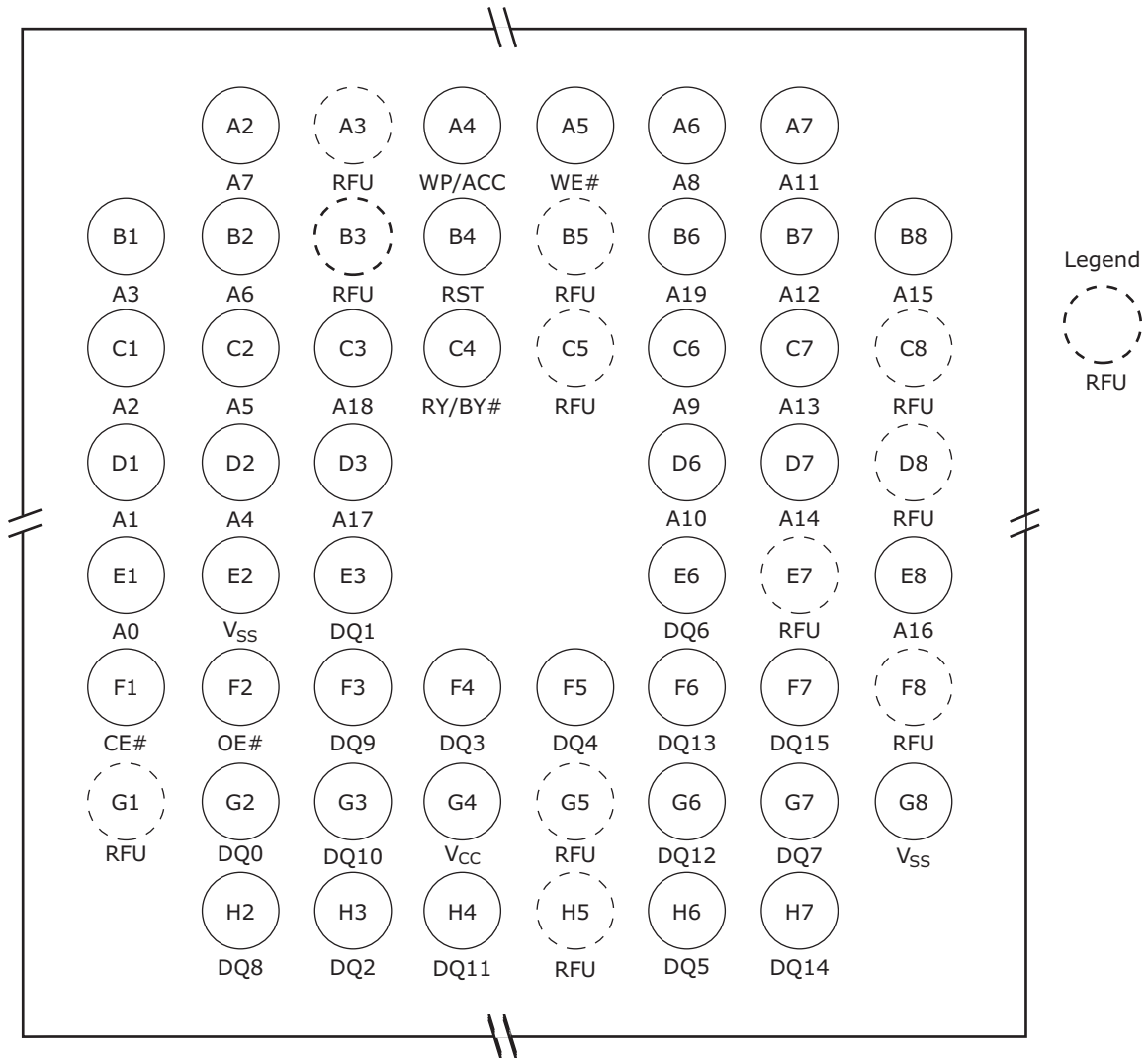

**Note:** MCP-compatible Connection Diagram for cellular handsets only

**48-ball Fine-pitch BGA**  
Top View, Balls Facing Down

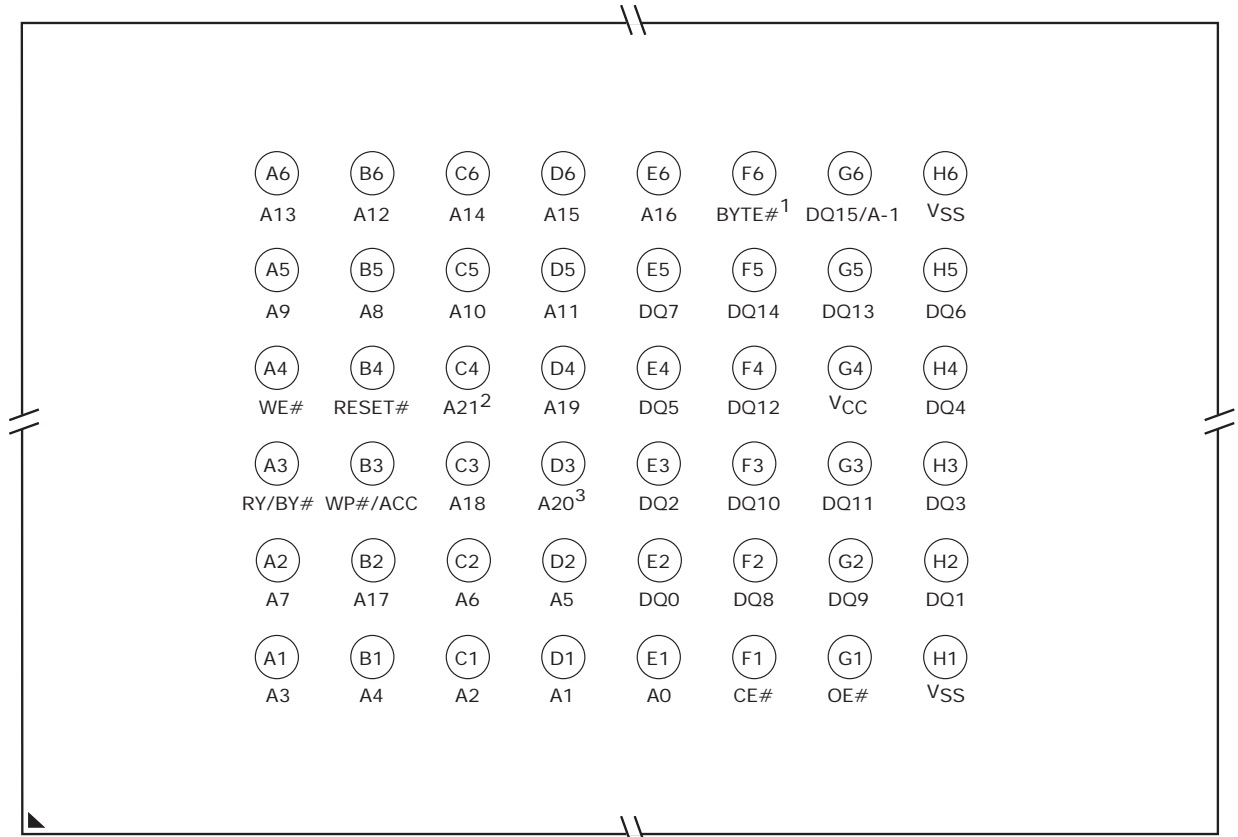

**Notes:**

1. Ball F6 is  $V_{IO}$  on S29GL064A (model R5).
2. Ball C4 is NC on S29GL032A and S29GL016A.
3. Ball D3 is NC on S29GL016A.

## Pin Descriptions

A21-A0	=	22 Address inputs
A20-A0	=	21 Address inputs
A19-A0	=	20 Address inputs
DQ7-DQ0	=	8 Data inputs/outputs
DQ14-DQ0	=	15 Data inputs/outputs
DQ15/A-1	=	DQ15 (Data input/output, word mode), A-1 (LSB Address input, byte mode)
CE#	=	Chip Enable input
OE#	=	Output Enable input
WE#	=	Write Enable input
WP#/ACC	=	Hardware Write Protect input/Programming Acceleration input
ACC	=	Acceleration input
WP#	=	Hardware Write Protect input
RESET#	=	Hardware Reset Pin input
RY/BY#	=	Ready/Busy output
BYTE#	=	Selects 8-bit or 16-bit mode
V <sub>CC</sub>	=	3.0 volt-only single power supply (see Product Selector Guide for speed options and voltage supply tolerances)
V <sub>SS</sub>	=	Device Ground
NC	=	Pin Not Connected Internally
V <sub>IO</sub>	=	Output Buffer Power

## Logic Symbols

### Logic Symbol-S29GL064A (Models R1, R2, R8, R9)

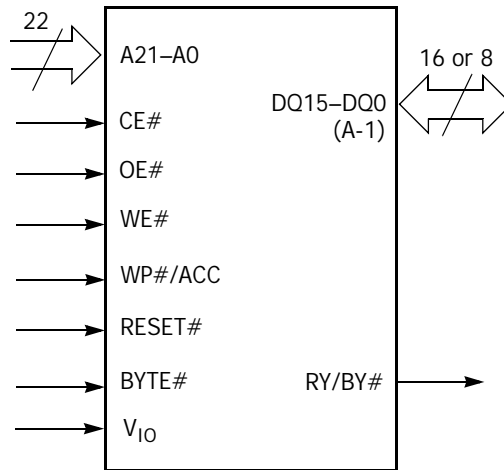

**Logic Symbol–S29GL064A (Models R3, R4)**

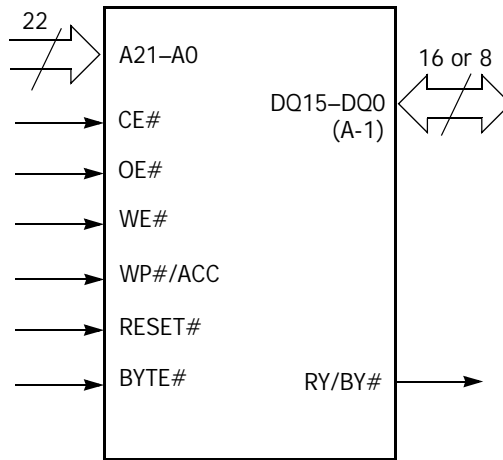

**Logic Symbol–S29GL064A (Model R5)**

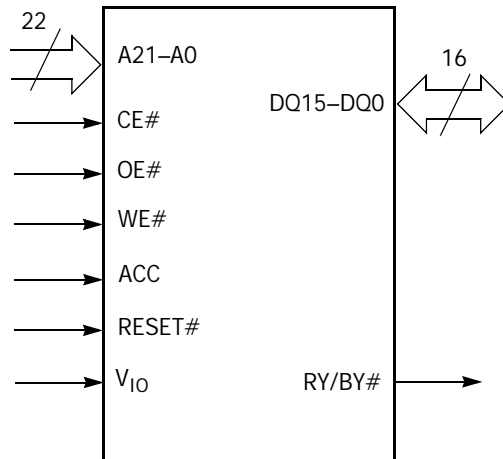

**Logic Symbol–S29GL064A (Models R6, R7)**

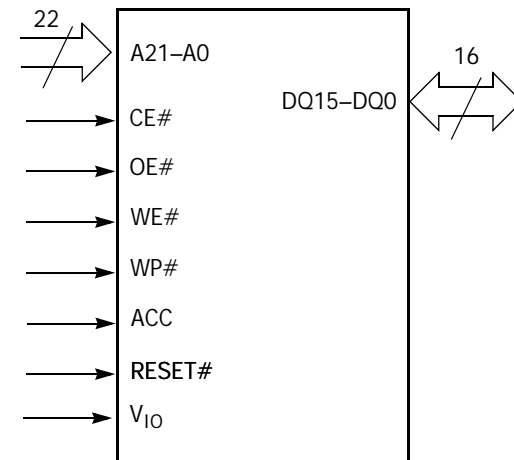

**Logic Symbol–S29GL064A (Models W1, W2, WE, and W4)**

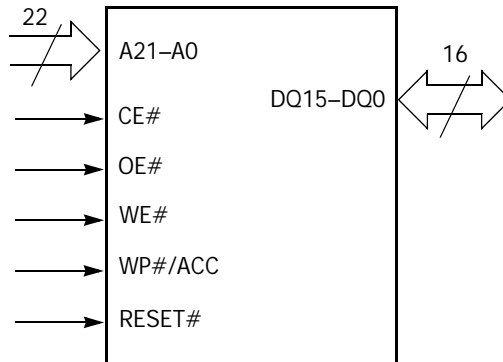

**Logic Symbol–S29GL032A (Models R1, R2)**

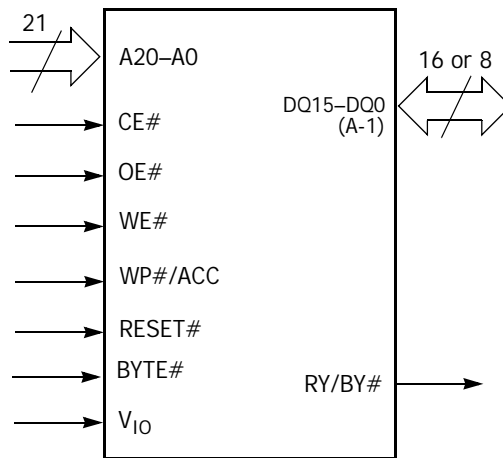

**Logic Symbol–S29GL032A (Models R3, R4)**

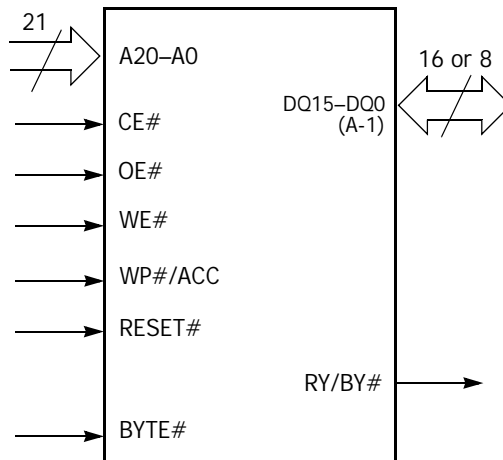



**Logic Symbol–S29GL032A (Models W1,W2,W3, and W4)**

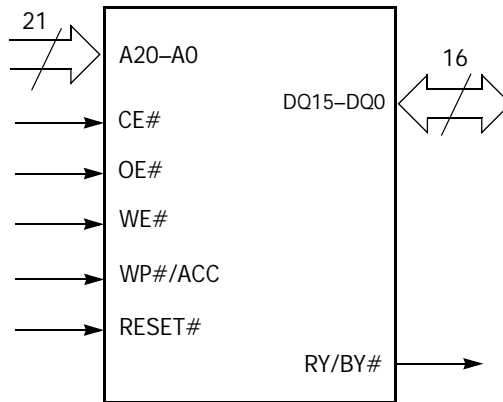

**Logic Symbol–S29GL016A (Models R1, R2)**

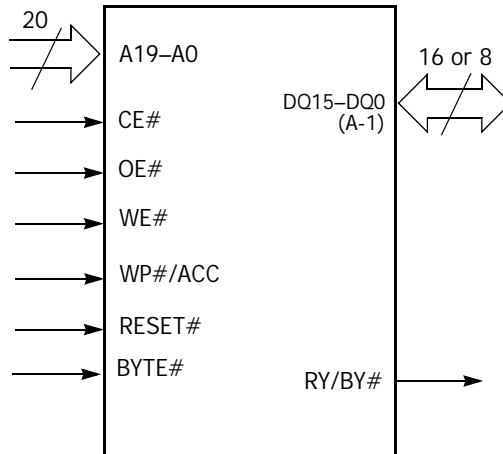

**Logic Symbol–S29GL016A (Models W3,W4)**

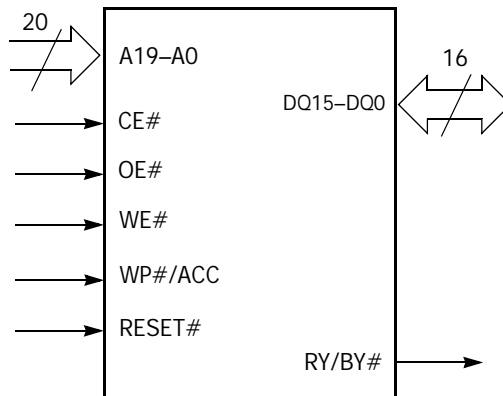

# Ordering Information–S29GL016A

## S29GL016A Standard Products

Standard products are available in several packages and operating ranges. The order number (Valid Combination) is formed by a combination of the following:

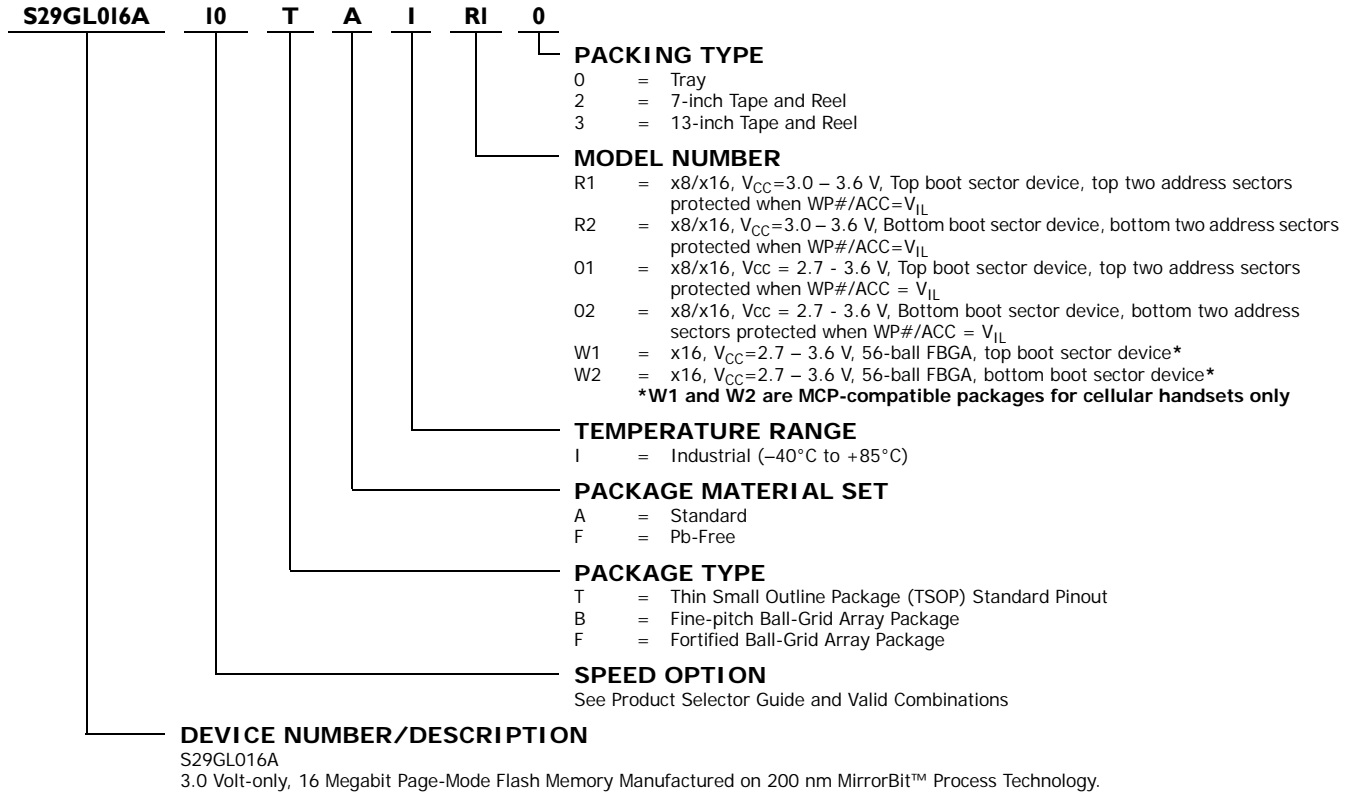

Table I. S29GL016A Ordering Options

S29GL016A Valid Combinations					Package Description (Notes)	
Device Number	Speed Option	Package, Material, & Temperature Range	Model Number	Packing Type (Note 1)		
S29GL016A	90, 10	TAI, TFI	R1, R2	0, 3	TS048 (Note 2)	TSOP
		BAI, BFI		0, 2, 3	VBK048 (Note 3)	Fine-Pitch BGA
		FAI, FFI			LAA064 (Note 3)	Fortified BGA
	10	BAI, BFI	W1, W2	0, 3	VBU056 (Note 3)	Fine-Pitch BGA (For cellular handsets only)
		TAI, TFI	01, 02		TS048 (Note 2)	TSOP
		BAI, BFI			0, 2, 3	VBK048 (Note 3)
FAI, FFI	LAA064 (Note 3)	Fortified BGA				

**Notes:**

- Type 0 is standard. Specify others as required: TSOPs can be packed in Types 0 and 3; BGAs can be packed in Types 0, 2, or 3.
- TSOP package marking omits packing type designator from ordering part number.
- BGA package marking omits leading S29 and packing type designator from ordering part number.

**Valid Combinations**

Valid Combinations list configurations planned to be supported in volume for this device. Consult your local sales office to confirm availability of specific valid combinations and to check on newly released combinations.

# Ordering Information–S29GL032A

## S29GL032A Standard Products

Standard products are available in several packages and operating ranges. The order number (Valid Combination) is formed by a combination of the following:

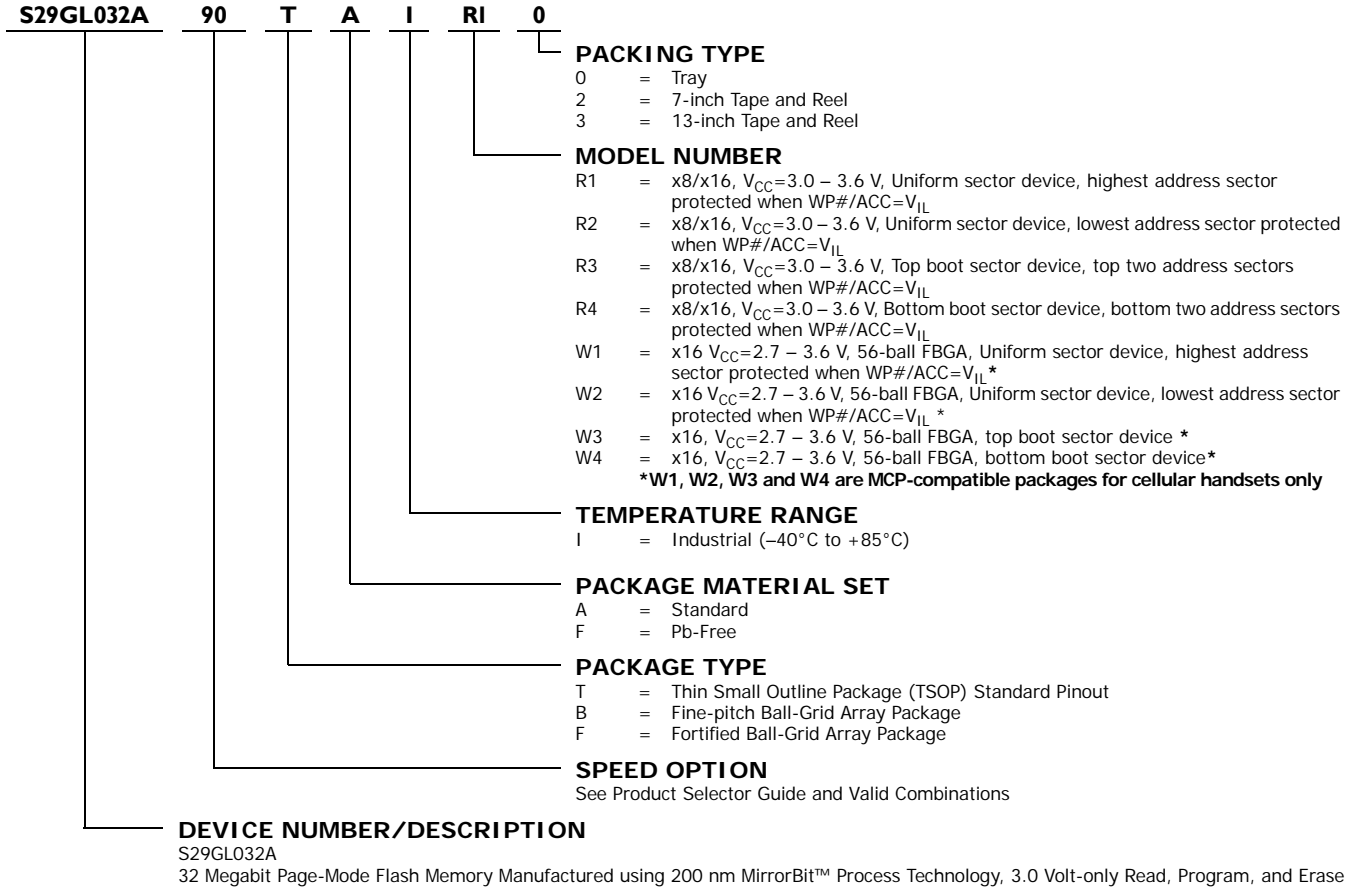

**Table 2. S29GL032A Ordering Options**

S29GL032A Valid Combinations					Package Description (Notes)	
Device Number	Speed Option	Package, Material, & Temperature Range	Model Number	Packing Type		
S29GL032A	90, 10, 11	TAI,TFI	R1, R2	0,2,3 (Note 1)	TS056 (Note 2)	TSOP
		FAI,FFI			LAA064 (Note 3)	Fortified BGA
		TAI,TFI	R3,R4		TS048 (Note 2)	TSOP
		BAI,BFI			VBK048 (Note 3)	Fine-Pitch BGA
		FAI,FFI			LAA064 (Note 3)	Fortified BGA
	10, 11	BAI,BFI	W1,W2,W3,W4		VBU056 (Note 3)	Fine-Pitch BGA (For cellular handsets only)

**Notes:**

- Type 0 is standard. Specify others as required: TSOPs can be packed in Types 0 and 3; BGAs can be packed in Types 0, 2, or 3.
- TSOP package marking omits packing type designator from ordering part number.
- BGA package marking omits leading S29 and packing type designator from ordering part number.

**Valid Combinations**

Valid Combinations list configurations planned to be supported in volume for this device. Consult your local sales office to confirm availability of specific valid combinations and to check on newly released combinations.

# Ordering Information–S29GL064A

## S29GL064A Standard Products

Standard products are available in several packages and operating ranges. The order number (Valid Combination) is formed by a combination of the following:

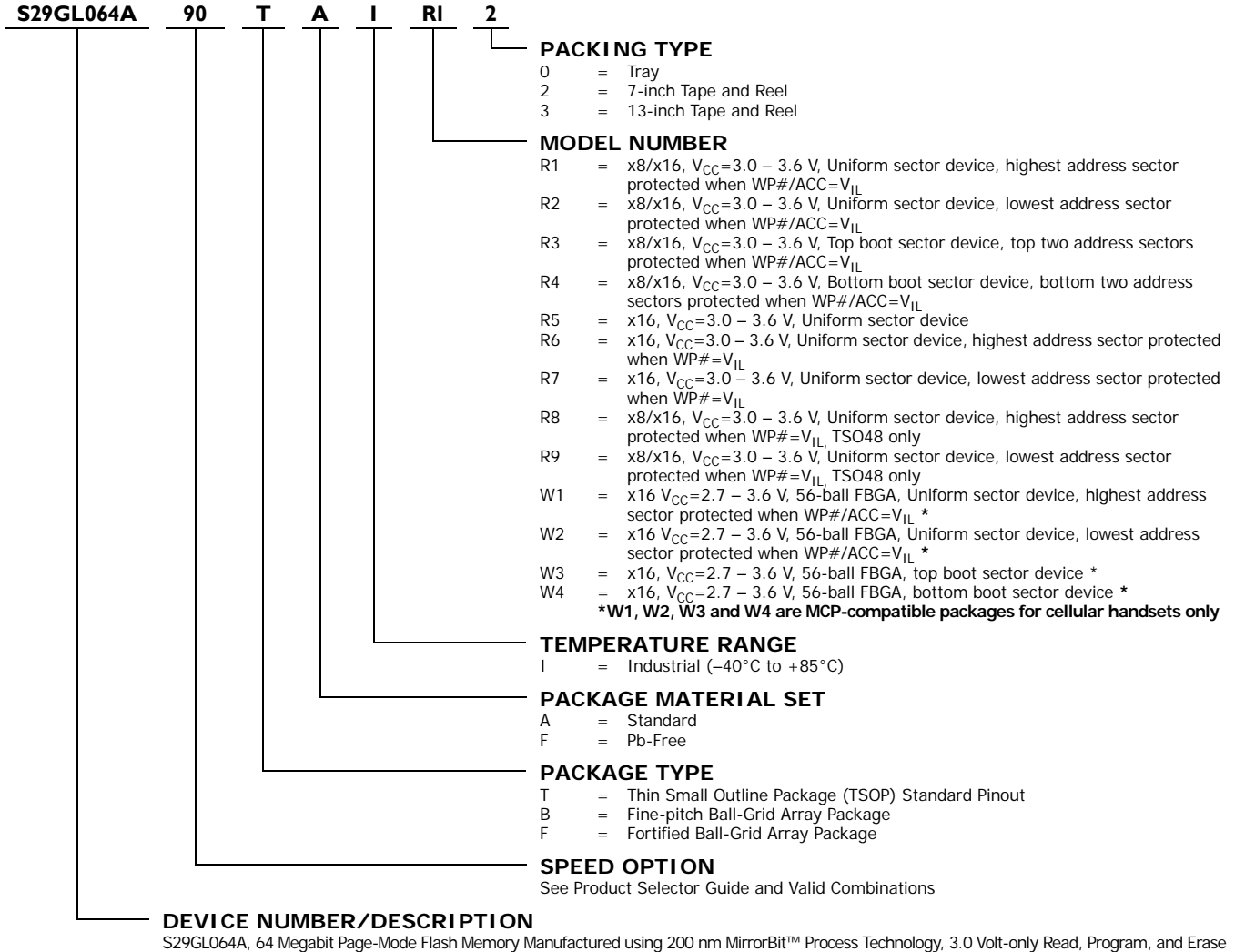

**Table 3. S29GL064A Valid Combinations**

S29GL064A Valid Combinations					Package Description	
Device Number	Speed Option	Package, Material & Temperature Range	Model Number	Packing Type		
S29GL064A	90, 10, 11	TAI, TFI	R3, R4, R6, R7, R8, R9	0, 2, 3 (Note 1)	TS048 (Note 2)	TSOP
			R1, R2		TS056 (Note 2)	TSOP
		BAI, BFI	R3, R4, R5		VBNO48 (Note 3)	Fine-pitch BGA
		FAI, FFI	R1, R2, R3, R4, R5		LAA064 (Note 3)	Fortified BGA
	10, 11	BAI, BFI	W1, W2, W3, W4		VBH064 (Note 3)	Fine-Pitch BGA (For cellular handsets only)

**Notes:**

- Type 0 is standard. Specify others as required: TSOPs can be packed in Types 0 and 3; BGAs can be packed in Types 0, 2, or 3.
- TSOP package marking omits packing type designator from ordering part number.
- BGA package marking omits leading S29 and packing type designator from ordering part number.

**Valid Combinations**

Valid Combinations list configurations planned to be supported in volume for this device. Consult your local sales office to confirm availability of specific valid combinations and to check on newly released combinations.

## Device Bus Operations

This section describes the requirements and use of the device bus operations, which are initiated through the internal command register. The command register itself does not occupy any addressable memory location. The register is a latch used to store the commands, along with the address and data information needed to execute the command. The contents of the register serve as inputs to the internal state machine. The state machine outputs dictate the function of the device. Table 4 lists the device bus operations, the inputs and control levels they require, and the resulting output. The following subsections describe each of these operations in further detail.

**Table 4. Device Bus Operations**

Operation	CE#	OE#	WE#	RESET#	WP#	ACC	Addresses (Note 1)	DQ0– DQ7	DQ8–DQ15	
									BYTE# = V <sub>IH</sub>	BYTE# = V <sub>IL</sub>
Read	L	L	H	H	X	X	A <sub>IN</sub>	D <sub>OUT</sub>	D <sub>OUT</sub>	DQ8–DQ14 = High-Z, DQ15 = A-1
Write (Program/Erase)	L	H	L	H	(Note 3)	X	A <sub>IN</sub>	(Note 4)	(Note 4)	
Accelerated Program	L	H	L	H	(Note 3)	V <sub>HH</sub>	A <sub>IN</sub>	(Note 4)	(Note 4)	
Standby	V <sub>CC</sub> ± 0.3 V	X	X	V <sub>CC</sub> ± 0.3 V	X	H	X	High-Z	High-Z	High-Z
Output Disable	L	H	H	H	X	X	X	High-Z	High-Z	High-Z
Reset	X	X	X	L	X	X	X	High-Z	High-Z	High-Z
Sector Group Protect (Note 2)	L	H	L	V <sub>ID</sub>	H	X	SA, A6=L, A3=L, A2=L, A1=H, A0=L	(Note 4)	X	X
Sector Group Unprotect (Note 2)	L	H	L	V <sub>ID</sub>	H	X	SA, A6=H, A3=L, A2=L, A1=H, A0=L	(Note 4)	X	X
Temporary Sector Group Unprotect	X	X	X	V <sub>ID</sub>	H	X	A <sub>IN</sub>	(Note 4)	(Note 4)	High-Z

**Legend:** L = Logic Low = V<sub>IL</sub>, H = Logic High = V<sub>IH</sub>, V<sub>ID</sub> = 11.5–12.5 V, V<sub>HH</sub> = 11.5–12.5 V, X = Don't Care, SA = Sector Address, A<sub>IN</sub> = Address In, D<sub>IN</sub> = Data In, D<sub>OUT</sub> = Data Out

**Notes:**

- Addresses are Amax:A0 in word mode; Amax:A-1 in byte mode. Sector addresses are Amax:A15 in both modes.
- The sector protect and sector unprotect functions may also be implemented via programming equipment. See the "Sector Group Protection and Unprotection" section.
- If WP# = V<sub>IL</sub>, the first or last sector remains protected (for uniform sector devices), and the two outer boot sectors are protected (for boot sector devices). If WP# = V<sub>IH</sub>, the first or last sector, or the two outer boot sectors are protected or unprotected as determined by the method described in [Sector Group Protection and Unprotection on page 38](#). All sectors are unprotected when shipped from the factory (The Secured Silicon Sector may be factory protected depending on version ordered.)
- D<sub>IN</sub> or D<sub>OUT</sub> as required by command sequence, data polling, or sector protect algorithm (see [Figure 7, on page 64](#)).

## Word/Byte Configuration

The BYTE# pin controls whether the device data I/O pins operate in the byte or word configuration. If the BYTE# pin is set at logic 1, the device is in word configuration, DQ0–DQ15 are active and controlled by CE# and OE#.

If the BYTE# pin is set at logic 0, the device is in byte configuration, and only data I/O pins DQ0–DQ7 are active and controlled by CE# and OE#. The data I/O pins DQ8–DQ14 are tri-stated, and the DQ15 pin is used as an input for the LSB (A-1) address function.

## Requirements for Reading Array Data

To read array data from the outputs, the system must drive the CE# and OE# pins to  $V_{IL}$ . CE# is the power control and selects the device. OE# is the output control and gates array data to the output pins. WE# should remain at  $V_{IH}$ .

The internal state machine is set for reading array data upon device power-up, or after a hardware reset. This ensures that no spurious alteration of the memory content occurs during the power transition. No command is necessary in this mode to obtain array data. Standard microprocessor read cycles that assert valid addresses on the device address inputs produce valid data on the device data outputs. The device remains enabled for read access until the command register contents are altered.

See [Reading Array Data on page 50](#) for more information. Refer to the AC Read-Only Operations table for timing specifications and the timing diagram. Refer to the DC Characteristics table for the active current specification on reading array data.

### Page Mode Read

The device is capable of fast page mode read and is compatible with the page mode Mask ROM read operation. This mode provides faster read access speed for random locations within a page. The page size of the device is 4 words/8 bytes. The appropriate page is selected by the higher address bits A(max)–A2. Address bits A1–A0 in word mode (A1–A-1 in byte mode) determine the specific word within a page. This is an asynchronous operation; the microprocessor supplies the specific word location.

The random or initial page access is equal to  $t_{ACC}$  or  $t_{CE}$  and subsequent page read accesses (as long as the locations specified by the microprocessor falls within that page) is equivalent to  $t_{PACC}$ . When CE# is deasserted and reasserted for a subsequent access, the access time is  $t_{ACC}$  or  $t_{CE}$ . Fast page mode accesses are obtained by keeping the *read-page addresses* constant and changing the *intra-read page addresses*.

## Writing Commands/Command Sequences

To write a command or command sequence (which includes programming data to the device and erasing sectors of memory), the system must drive WE# and CE# to  $V_{IL}$ , and OE# to  $V_{IH}$ .

The device features an **Unlock Bypass** mode to facilitate faster programming. Once the device enters the Unlock Bypass mode, only two write cycles are required to program a word, instead of four. The [Word Program Command Sequence on page 51](#) contains details on programming data to the device using both standard and Unlock Bypass command sequences.

An erase operation can erase one sector, multiple sectors, or the entire device. [Tables 7 – 25](#) indicate the address space that each sector occupies.

Refer to the DC Characteristics table for the active current specification for the write mode. The AC Characteristics section contains timing specification tables and timing diagrams for write operations.

### Write Buffer

Write Buffer Programming allows the system write to a maximum of 16 words/32 bytes in one programming operation. This results in faster effective programming time than the standard programming algorithms. See [Write Buffer on page 21](#) for more information.

### Accelerated Program Operation

The device offers accelerated program operations through the ACC function. This is one of two functions provided by the WP#/ACC or ACC pin, depending on model number. This function is primarily intended to allow faster manufacturing throughput at the factory.

If the system asserts  $V_{HH}$  on this pin, the device automatically enters the aforementioned Unlock Bypass mode, temporarily unprotects any protected sector groups, and uses the higher voltage on the pin to reduce the time required for program operations. The system would use a two-cycle program command sequence as required by the Unlock Bypass mode. Removing  $V_{HH}$  from the WP#/ACC or ACC pin, depending on model number, returns the device to normal operation. *Note that the WP#/ACC or ACC pin must not be at  $V_{HH}$  for operations other than accelerated programming, or device damage may result. WP# contains an internal pullup; when unconnected, WP# is at  $V_{IH}$ .*

### Autoselect Functions

If the system writes the autoselect command sequence, the device enters the autoselect mode. The system can then read autoselect codes from the internal register (which is separate from the memory array) on DQ7–DQ0. Standard read cycle timings apply in this mode. Refer to [Autoselect Mode on page 37](#) and [Autoselect Command Sequence on page 51](#) for more information.

## Standby Mode

When the system is not reading or writing to the device, it can place the device in the standby mode. In this mode, current consumption is greatly reduced, and the outputs are placed in the high impedance state, independent of the OE# input.

The device enters the CMOS standby mode when the CE# and RESET# pins are both held at  $V_{IO} \pm 0.3$  V. (Note that this is a more restricted voltage range than  $V_{IH}$ .) If CE# and RESET# are held at  $V_{IH}$ , but not within  $V_{IO} \pm 0.3$  V, the device is in the standby mode, but the standby current is greater. The device requires standard access time ( $t_{CE}$ ) for read access when the device is in either of these standby modes, before it is ready to read data.

If the device is deselected during erasure or programming, the device draws active current until the operation is completed.

Refer to the [DC Characteristics on page 71](#) for the standby current specification.

## Automatic Sleep Mode

The automatic sleep mode minimizes Flash device energy consumption. The device automatically enables this mode when addresses remain stable for  $t_{ACC} + 30$  ns. The automatic sleep mode is independent of the CE#, WE#, and OE# control signals. Standard address access timings provide new data when addresses are changed. While in sleep mode, output data is latched and always available to the system. Refer to the [DC Characteristics on page 71](#) for the automatic sleep mode current specification.

## RESET#: Hardware Reset Pin

The RESET# pin provides a hardware method of resetting the device to reading array data. When the RESET# pin is driven low for at least a period of  $t_{RP}$ , the device immediately terminates any operation in progress, tristates all output pins, and ignores all read/write commands for the duration of the RESET# pulse. The device also resets the internal state machine to reading array data. The operation that was interrupted should be reinitiated once the device is ready to accept another command sequence, to ensure data integrity.

Current is reduced for the duration of the RESET# pulse. When RESET# is held at  $V_{SS} \pm 0.3$  V, the device draws CMOS standby current ( $I_{CC5}$ ). If RESET# is held at  $V_{IL}$  but not within  $V_{SS} \pm 0.3$  V, the standby current is greater.

The RESET# pin may be tied to the system reset circuitry. A system reset would thus also reset the Flash memory, enabling the system to read the boot-up firmware from the Flash memory.

Refer to the AC Characteristics tables for RESET# parameters and to [Figure 15, on page 75](#) for the timing diagram.

## Output Disable Mode

When the OE# input is at  $V_{IH}$ , output from the device is disabled. The output pins are placed in the high impedance state.



**Table 5. S29GL016A (Model RI, WI) Top Boot Sector Addresses**

Sector	A19–A12	Sector Size (KB/Kwords)	8-bit Address Range	16-bit Address Range	Sector	A19–A12	Sector Size (KB/Kwords)	8-bit Address Range	16-bit Address Range
SA0	000000xxx	64/32	000000h–00FFFFh	00000h–07FFFh	SA20	010100xxx	64/32	140000h–14FFFFh	A0000h–A7FFFh
SA1	000001xxx	64/32	010000h–01FFFFh	08000h–0FFFFh	SA21	010101xxx	64/32	150000h–15FFFFh	A8000h–AFFFFh
SA2	000010xxx	64/32	020000h–02FFFFh	10000h–17FFFh	SA22	010110xxx	64/32	160000h–16FFFFh	B0000h–B7FFFh
SA3	000011xxx	64/32	030000h–03FFFFh	18000h–1FFFFh	SA23	010111xxx	64/32	170000h–17FFFFh	B8000h–BFFFFh
SA4	000100xxx	64/32	040000h–04FFFFh	20000h–27FFFh	SA24	011000xxx	64/32	180000h–18FFFFh	C0000h–C7FFFh
SA5	000101xxx	64/32	050000h–05FFFFh	28000h–2FFFFh	SA25	011001xxx	64/32	190000h–19FFFFh	C8000h–CFFFFh
SA6	000110xxx	64/32	060000h–06FFFFh	30000h–37FFFh	SA26	011010xxx	64/32	1A0000h–1AFFFFh	D0000h–D7FFFh
SA7	000111xxx	64/32	070000h–07FFFFh	38000h–3FFFFh	SA27	011011xxx	64/32	1B0000h–1BFFFFh	D8000h–DFFFFh
SA8	001000xxx	64/32	080000h–08FFFFh	40000h–47FFFh	SA28	011000xxx	64/32	1C0000h–1CFFFFh	E0000h–E7FFFh
SA9	001001xxx	64/32	090000h–09FFFFh	48000h–4FFFFh	SA29	011101xxx	64/32	1D0000h–1DFFFFh	E8000h–EFFFFh
SA10	001010xxx	64/32	0A0000h–0AFFFFh	50000h–57FFFh	SA30	011110xxx	64/32	1E0000h–1EFFFFh	F0000h–F7FFFh
SA11	001011xxx	64/32	0B0000h–0BFFFFh	58000h–5FFFFh	SA31	111111000	8/4	1F0000h–1F1FFFh	0F8000h–0F8FFFh
SA12	001100xxx	64/32	0C0000h–0CFFFFh	60000h–67FFFh	SA32	111111001	8/4	1F2000h–1F3FFFh	0F9000h–0F9FFFh
SA13	001101xxx	64/32	0D0000h–0DFFFFh	68000h–6FFFFh	SA33	111111010	8/4	1F4000h–1F5FFFh	0FA000h–0FAFFFh
SA14	001101xxx	64/32	0E0000h–0EFFFFh	70000h–77FFFh	SA34	111111011	8/4	1F6000h–1F7FFFh	0FB000h–0FBFFFh
SA15	001111xxx	64/32	0F0000h–0FFFFFh	78000h–7FFFFh	SA35	111111100	8/4	1F8000h–1F9FFFh	0FC000h–0FCFFFh
SA16	010000xxx	64/32	100000h–00FFFFh	80000h–87FFFh	SA36	111111101	8/4	1FA000h–1FBFFFh	0FD000h–0FDFFFh
SA17	010001xxx	64/32	110000h–11FFFFh	88000h–8FFFFh	SA37	111111110	8/4	1FC000h–1FDFFFh	0FE000h–0FEFFFh
SA18	010010xxx	64/32	120000h–12FFFFh	90000h–97FFFh	SA38	111111111	8/4	1FE000h–1FFFFFh	0FF000h–0FFFFFh
SA19	010011xxx	64/32	130000h–13FFFFh	98000h–9FFFFh					

**Table 6. S29GL016A (Model R2, W2)  
Bottom Boot Sector Addresses**

Sector	A19-A12	Sector Size (KB/Kwords)	8-bit Address Range	16-bit Address Range	Sector	A19-A12	Sector Size (KB/Kwords)	8-bit Address Range	16-bit Address Range
SA0	000000000	8/4	000000h-001FFFh	00000h-00FFFh	SA19	001100xxx	64/32	0C0000h-0CFFFFh	60000h-67FFFh
SA1	000000001	8/4	002000h-003FFFh	01000h-01FFFh	SA20	001101xxx	64/32	0D0000h-0DFFFFh	68000h-6FFFFh
SA2	000000010	8/4	004000h-005FFFh	02000h-02FFFh	SA21	001101xxx	64/32	0E0000h-0EFFFFh	70000h-77FFFh
SA3	000000011	8/4	006000h-007FFFh	03000h-03FFFh	SA22	001111xxx	64/32	0F0000h-0FFFFFh	78000h-7FFFFh
SA4	000000100	8/4	008000h-009FFFh	04000h-04FFFh	SA23	010000xxx	64/32	100000h-00FFFFh	80000h-87FFFh
SA5	000000101	8/4	00A000h-00BFFFh	05000h-05FFFh	SA24	010001xxx	64/32	110000h-11FFFFh	88000h-8FFFFh
SA6	000000110	8/4	00C000h-00DFFFh	06000h-06FFFh	SA25	010010xxx	64/32	120000h-12FFFFh	90000h-97FFFh
SA7	000000111	8/4	00E000h-00FFFFh	07000h-07FFFh	SA26	010011xxx	64/32	130000h-13FFFFh	98000h-9FFFFh
SA8	000001xxx	64/32	010000h-01FFFFh	08000h-0FFFFh	SA27	010100xxx	64/32	140000h-14FFFFh	A0000h-A7FFFh
SA9	000010xxx	64/32	020000h-02FFFFh	10000h-17FFFh	SA28	010101xxx	64/32	150000h-15FFFFh	A8000h-AFFFFh
SA10	000011xxx	64/32	030000h-03FFFFh	18000h-1FFFFh	SA29	010110xxx	64/32	160000h-16FFFFh	B0000h-B7FFFh
SA11	000100xxx	64/32	040000h-04FFFFh	20000h-27FFFh	SA30	010111xxx	64/32	170000h-17FFFFh	B8000h-BFFFFh
SA12	000101xxx	64/32	050000h-05FFFFh	28000h-2FFFFh	SA31	011000xxx	64/32	180000h-18FFFFh	C0000h-C7FFFh
SA13	000110xxx	64/32	060000h-06FFFFh	30000h-37FFFh	SA32	011001xxx	64/32	190000h-19FFFFh	C8000h-CFFFFh
SA14	000111xxx	64/32	070000h-07FFFFh	38000h-3FFFFh	SA33	011010xxx	64/32	1A0000h-1AFFFFh	D0000h-D7FFFh
SA15	001000xxx	64/32	080000h-08FFFFh	40000h-47FFFh	SA34	011011xxx	64/32	1B0000h-1BFFFFh	D8000h-DFFFFh
SA16	001001xxx	64/32	090000h-09FFFFh	48000h-4FFFFh	SA35	011000xxx	64/32	1C0000h-1CFFFFh	E0000h-E7FFFh
SA17	001010xxx	64/32	0A0000h-0AFFFFh	50000h-57FFFh	SA36	011101xxx	64/32	1D0000h-1DFFFFh	E8000h-EFFFFh
SA18	001011xxx	64/32	0B0000h-0BFFFFh	58000h-5FFFFh	SA37	011110xxx	64/32	1E0000h-1EFFFFh	F0000h-F7FFFh
					SA38	011111xxx	64/32	1F0000h-1FFFFFh	F8000h-FFFFFh

**Table 7. S29GL032A (Models RI, R2, WI, W2) Sector Addresses**

Sector	A20-A15	Sector Size (KB/Kwords)	8-bit Address Range	16-bit Address Range	Sector	A20-A15	Sector Size (KB/Kwords)	8-bit Address Range	16-bit Address Range
SA0	0 0 0 0 0 0	64/32	000000–00FFFF	000000–007FFF	SA32	1 1 0 0 0 0	64/32	200000–20FFFF	100000–107FFF
SA1	0 0 0 0 0 1	64/32	010000–01FFFF	008000–00FFFF	SA33	1 1 0 0 0 1	64/32	210000–21FFFF	108000–10FFFF
SA2	0 0 0 0 1 0	64/32	020000–02FFFF	010000–017FFF	SA34	1 1 0 0 1 0	64/32	220000–22FFFF	110000–117FFF
SA3	0 0 0 0 1 1	64/32	030000–03FFFF	018000–01FFFF	SA35	1 1 0 0 1 1	64/32	230000–23FFFF	118000–11FFFF
SA4	0 0 0 1 0 0	64/32	040000–04FFFF	020000–027FFF	SA36	1 1 0 1 0 0	64/32	240000–24FFFF	120000–127FFF
SA5	0 0 0 1 0 1	64/32	050000–05FFFF	028000–02FFFF	SA37	1 1 0 1 0 1	64/32	250000–25FFFF	128000–12FFFF
SA6	0 0 0 1 1 0	64/32	060000–06FFFF	030000–037FFF	SA38	1 1 0 1 1 0	64/32	260000–26FFFF	130000–137FFF
SA7	0 0 0 1 1 1	64/32	070000–07FFFF	038000–03FFFF	SA39	1 1 0 1 1 1	64/32	270000–27FFFF	138000–13FFFF
SA8	0 0 1 0 0 0	64/32	080000–08FFFF	040000–047FFF	SA40	1 1 0 1 0 0	64/32	280000–28FFFF	140000–147FFF
SA9	0 0 1 0 0 1	64/32	090000–09FFFF	048000–04FFFF	SA41	1 1 0 1 0 1	64/32	290000–29FFFF	148000–14FFFF
SA10	0 0 1 0 1 0	64/32	0A0000–0AFFFF	050000–057FFF	SA42	1 1 0 1 1 0	64/32	2A0000–2AFFFF	150000–157FFF
SA11	0 0 1 0 1 1	64/32	0B0000–0BFFFF	058000–05FFFF	SA43	1 1 0 1 1 1	64/32	2B0000–2BFFFF	158000–15FFFF
SA12	0 0 1 1 0 0	64/32	0C0000–0CFFFF	060000–067FFF	SA44	1 1 0 1 1 0	64/32	2C0000–2CFFFF	160000–167FFF
SA13	0 0 1 1 0 1	64/32	0D0000–0DFFFF	068000–06FFFF	SA45	1 1 0 1 1 1	64/32	2D0000–2DFFFF	168000–16FFFF
SA14	0 0 1 1 1 0	64/32	0E0000–0EFFFF	070000–077FFF	SA46	1 1 0 1 1 0	64/32	2E0000–2EFFFF	170000–177FFF
SA15	0 0 1 1 1 1	64/32	0F0000–0FFFFF	078000–07FFFF	SA47	1 1 0 1 1 1	64/32	2F0000–2FFFFF	178000–17FFFF
SA16	0 1 0 0 0 0	64/32	100000–10FFFF	080000–087FFF	SA48	1 1 1 0 0 0	64/32	300000–30FFFF	180000–187FFF
SA17	0 1 0 0 0 1	64/32	110000–11FFFF	088000–08FFFF	SA49	1 1 1 0 0 1	64/32	310000–31FFFF	188000–18FFFF
SA18	0 1 0 0 1 0	64/32	120000–12FFFF	090000–097FFF	SA50	1 1 1 0 1 0	64/32	320000–32FFFF	190000–197FFF
SA19	0 1 0 0 1 1	64/32	130000–13FFFF	098000–09FFFF	SA51	1 1 1 0 1 1	64/32	330000–33FFFF	198000–19FFFF
SA20	0 1 0 1 0 0	64/32	140000–14FFFF	0A0000–0A7FFF	SA52	1 1 1 0 1 0	64/32	340000–34FFFF	1A0000–1A7FFF
SA21	0 1 0 1 0 1	64/32	150000–15FFFF	0A8000–0AFFFF	SA53	1 1 1 0 1 1	64/32	350000–35FFFF	1A8000–1AFFFF
SA22	0 1 0 1 1 0	64/32	160000–16FFFF	0B0000–0B7FFF	SA54	1 1 1 0 1 0	64/32	360000–36FFFF	1B0000–1B7FFF
SA23	0 1 0 1 1 1	64/32	170000–17FFFF	0B8000–0BFFFF	SA55	1 1 1 0 1 1	64/32	370000–37FFFF	1B8000–1BFFFF
SA24	0 1 1 0 0 0	64/32	180000–18FFFF	0C0000–0C7FFF	SA56	1 1 1 1 0 0	64/32	380000–38FFFF	1C0000–1C7FFF
SA25	0 1 1 0 0 1	64/32	190000–19FFFF	0C8000–0CFFFF	SA57	1 1 1 1 0 1	64/32	390000–39FFFF	1C8000–1CFFFF
SA26	0 1 1 0 1 0	64/32	1A0000–1AFFFF	0D0000–0D7FFF	SA58	1 1 1 1 1 0	64/32	3A0000–3AFFFF	1D0000–1D7FFF
SA27	0 1 1 0 1 1	64/32	1B0000–1BFFFF	0D8000–0DFFFF	SA59	1 1 1 1 1 1	64/32	3B0000–3BFFFF	1D8000–1DFFFF
SA28	0 1 1 1 0 0	64/32	1C0000–1CFFFF	0E0000–0E7FFF	SA60	1 1 1 1 1 0	64/32	3C0000–3CFFFF	1E0000–1E7FFF
SA29	0 1 1 1 0 1	64/32	1D0000–1DFFFF	0E8000–0EFFFF	SA61	1 1 1 1 1 1	64/32	3D0000–3DFFFF	1E8000–1EFFFF
SA30	0 1 1 1 1 0	64/32	1E0000–1EFFFF	0F0000–0F7FFF	SA62	1 1 1 1 1 0	64/32	3E0000–3EFFFF	1F0000–1F7FFF
SA31	0 1 1 1 1 1	64/32	1F0000–1FFFFF	0F8000–0FFFFF	SA63	1 1 1 1 1 1	64/32	3F0000–3FFFFF	1F8000–1FFFFF

**Table 8. S29GL032A (Model R3, W3) Top Boot Sector Addresses**

Sector	A20–A12	Sector Size (KB/Kwords)	8-bit Address Range	16-bit Address Range	Sector	A20–A12	Sector Size (KB/Kwords)	8-bit Address Range	16-bit Address Range
SA0	000000xxx	64/32	000000h–00FFFFh	00000h–07FFFh	SA36	100100xxx	64/32	240000h–24FFFFh	120000h–127FFFh
SA1	000001xxx	64/32	010000h–01FFFFh	08000h–0FFFFh	SA37	100101xxx	64/32	250000h–25FFFFh	128000h–12FFFFh
SA2	000010xxx	64/32	020000h–02FFFFh	10000h–17FFFh	SA38	100110xxx	64/32	260000h–26FFFFh	130000h–137FFFh
SA3	000011xxx	64/32	030000h–03FFFFh	18000h–1FFFFh	SA39	100111xxx	64/32	270000h–27FFFFh	138000h–13FFFFh
SA4	000100xxx	64/32	040000h–04FFFFh	20000h–27FFFh	SA40	101000xxx	64/32	280000h–28FFFFh	140000h–147FFFh
SA5	000101xxx	64/32	050000h–05FFFFh	28000h–2FFFFh	SA41	101001xxx	64/32	290000h–29FFFFh	148000h–14FFFFh
SA6	000110xxx	64/32	060000h–06FFFFh	30000h–37FFFh	SA42	101010xxx	64/32	2A0000h–2AFFFFh	150000h–157FFFh
SA7	000111xxx	64/32	070000h–07FFFFh	38000h–3FFFFh	SA43	101011xxx	64/32	2B0000h–2BFFFFh	158000h–15FFFFh
SA8	001000xxx	64/32	080000h–08FFFFh	40000h–47FFFh	SA44	101100xxx	64/32	2C0000h–2CFFFFh	160000h–167FFFh
SA9	001001xxx	64/32	090000h–09FFFFh	48000h–4FFFFh	SA45	101101xxx	64/32	2D0000h–2DFFFFh	168000h–16FFFFh
SA10	001010xxx	64/32	0A0000h–0AFFFFh	50000h–57FFFh	SA46	101110xxx	64/32	2E0000h–2EFFFFh	170000h–177FFFh
SA11	001011xxx	64/32	0B0000h–0BFFFFh	58000h–5FFFFh	SA47	101111xxx	64/32	2F0000h–2FFFFh	178000h–17FFFFh
SA12	001100xxx	64/32	0C0000h–0CFFFFh	60000h–67FFFh	SA48	110000xxx	64/32	300000h–30FFFFh	180000h–187FFFh
SA13	001101xxx	64/32	0D0000h–0DFFFFh	68000h–6FFFFh	SA49	110001xxx	64/32	310000h–31FFFFh	188000h–18FFFFh
SA14	001101xxx	64/32	0E0000h–0EFFFFh	70000h–77FFFh	SA50	110010xxx	64/32	320000h–32FFFFh	190000h–197FFFh
SA15	001111xxx	64/32	0F0000h–0FFFFh	78000h–7FFFFh	SA51	110011xxx	64/32	330000h–33FFFFh	198000h–19FFFFh
SA16	010000xxx	64/32	100000h–00FFFFh	80000h–87FFFh	SA52	100100xxx	64/32	340000h–34FFFFh	1A0000h–1A7FFFh
SA17	010001xxx	64/32	110000h–11FFFFh	88000h–8FFFFh	SA53	110101xxx	64/32	350000h–35FFFFh	1A8000h–1AFFFFh
SA18	010010xxx	64/32	120000h–12FFFFh	90000h–97FFFh	SA54	110110xxx	64/32	360000h–36FFFFh	1B0000h–1B7FFFh
SA19	010011xxx	64/32	130000h–13FFFFh	98000h–9FFFFh	SA55	110111xxx	64/32	370000h–37FFFFh	1B8000h–1BFFFFh
SA20	010100xxx	64/32	140000h–14FFFFh	A0000h–A7FFFh	SA56	111000xxx	64/32	380000h–38FFFFh	1C0000h–1C7FFFh
SA21	010101xxx	64/32	150000h–15FFFFh	A8000h–AFFFFh	SA57	111001xxx	64/32	390000h–39FFFFh	1C8000h–1CFFFFh
SA22	010110xxx	64/32	160000h–16FFFFh	B0000h–B7FFFh	SA58	111010xxx	64/32	3A0000h–3AFFFFh	1D0000h–1D7FFFh
SA23	010111xxx	64/32	170000h–17FFFFh	B8000h–BFFFFh	SA59	111011xxx	64/32	3B0000h–3BFFFFh	1D8000h–1DFFFFh
SA24	011000xxx	64/32	180000h–18FFFFh	C0000h–C7FFFh	SA60	111100xxx	64/32	3C0000h–3CFFFFh	1E0000h–1E7FFFh
SA25	011001xxx	64/32	190000h–19FFFFh	C8000h–CFFFFh	SA61	111101xxx	64/32	3D0000h–3DFFFFh	1E8000h–1EFFFFh
SA26	011010xxx	64/32	1A0000h–1AFFFFh	D0000h–D7FFFh	SA62	111110xxx	64/32	3E0000h–3EFFFFh	1F0000h–1F7FFFh
SA27	011011xxx	64/32	1B0000h–1BFFFFh	D8000h–DFFFFh	SA63	111111000	8/4	3F0000h–3F1FFFh	1F8000h–1F8FFFh
SA28	011100xxx	64/32	1C0000h–1CFFFFh	E0000h–E7FFFh	SA64	111111001	8/4	3F2000h–3F3FFFh	1F9000h–1F9FFFh
SA29	011101xxx	64/32	1D0000h–1DFFFFh	E8000h–EFFFFh	SA65	111111010	8/4	3F4000h–3F5FFFh	1FA000h–1FAFFFh
SA30	011110xxx	64/32	1E0000h–1EFFFFh	F0000h–F7FFFh	SA66	111111011	8/4	3F6000h–3F7FFFh	1FB000h–1FBFFFh
SA31	011111xxx	64/32	1F0000h–1FFFFh	F8000h–FFFFh	SA67	111111100	8/4	3F8000h–3F9FFFh	1FC000h–1FCFFFh
SA32	100000xxx	64/32	200000h–20FFFFh	F9000h–107FFFh	SA68	111111101	8/4	3FA000h–3FBFFFh	1FD000h–1FDFFFh
SA33	100001xxx	64/32	210000h–21FFFFh	108000h–10FFFFh	SA69	111111110	8/4	3FC000h–3FDFFFh	1FE000h–1FEFFFh
SA34	100010xxx	64/32	220000h–22FFFFh	110000h–117FFFh	SA70	111111111	8/4	3FE000h–3FFFFh	1FF000h–1FFFFh
SA35	101011xxx	64/32	230000h–23FFFFh	118000h–11FFFFh					

**Table 9. S29GL032A (Model R4, W4)  
Bottom Boot Sector Addresses**

Sector	A20-A12	Sector Size (KB/Kwords)	8-bit Address Range	16-bit Address Range	Sector	A20-A12	Sector Size (KB/Kwords)	8-bit Address Range	16-bit Address Range
SA0	000000000	8/4	000000h-001FFFh	00000h-00FFFh	SA19	001100xxx	64/32	0C0000h-0CFFFFh	60000h-67FFFh
SA1	000000001	8/4	002000h-003FFFh	01000h-01FFFh	SA20	001101xxx	64/32	0D0000h-0DFFFFh	68000h-6FFFFh
SA2	000000010	8/4	004000h-005FFFh	02000h-02FFFh	SA21	001101xxx	64/32	0E0000h-0EFFFFh	70000h-77FFFh
SA3	000000011	8/4	006000h-007FFFh	03000h-03FFFh	SA22	001111xxx	64/32	0F0000h-0FFFFFh	78000h-7FFFFh
SA4	000000100	8/4	008000h-009FFFh	04000h-04FFFh	SA23	010000xxx	64/32	100000h-00FFFFh	80000h-87FFFh
SA5	000000101	8/4	00A000h-00BFFFh	05000h-05FFFh	SA24	010001xxx	64/32	110000h-11FFFFh	88000h-8FFFFh
SA6	000000110	8/4	00C000h-00DFFFh	06000h-06FFFh	SA25	010010xxx	64/32	120000h-12FFFFh	90000h-97FFFh
SA7	000000111	8/4	00E000h-00FFFFh	07000h-07FFFh	SA26	010011xxx	64/32	130000h-13FFFFh	98000h-9FFFFh
SA8	000001xxx	64/32	010000h-01FFFh	08000h-0FFFFh	SA27	010100xxx	64/32	140000h-14FFFFh	A0000h-A7FFFh
SA9	000010xxx	64/32	020000h-02FFFh	10000h-17FFFh	SA28	010101xxx	64/32	150000h-15FFFFh	A8000h-AFFFFh
SA10	000011xxx	64/32	030000h-03FFFh	18000h-1FFFFh	SA29	010110xxx	64/32	160000h-16FFFFh	B0000h-B7FFFh
SA11	000100xxx	64/32	040000h-04FFFh	20000h-27FFFh	SA30	010111xxx	64/32	170000h-17FFFFh	B8000h-BFFFFh
SA12	000101xxx	64/32	050000h-05FFFh	28000h-2FFFFh	SA31	011000xxx	64/32	180000h-18FFFFh	C0000h-C7FFFh
SA13	000110xxx	64/32	060000h-06FFFh	30000h-37FFFh	SA32	011001xxx	64/32	190000h-19FFFFh	C8000h-CFFFFh
SA14	000111xxx	64/32	070000h-07FFFh	38000h-3FFFFh	SA33	011010xxx	64/32	1A0000h-1AFFFFh	D0000h-D7FFFh
SA15	001000xxx	64/32	080000h-08FFFh	40000h-47FFFh	SA34	011011xxx	64/32	1B0000h-1BFFFFh	D8000h-DFFFFh
SA16	001001xxx	64/32	090000h-09FFFh	48000h-4FFFFh	SA35	011000xxx	64/32	1C0000h-1CFFFFh	E0000h-E7FFFh
SA17	001010xxx	64/32	0A0000h-0AFFFFh	50000h-57FFFh	SA36	011101xxx	64/32	1D0000h-1DFFFFh	E8000h-EFFFFh
SA18	001011xxx	64/32	0B0000h-0BFFFFh	58000h-5FFFFh	SA37	011110xxx	64/32	1E0000h-1EFFFFh	F0000h-F7FFFh
SA38	011111xxx	64/32	1F0000h-1FFFFh	F8000h-FFFFh	SA55	110000xxx	64/32	300000h-30FFFFh	180000h-187FFFh
SA39	100000xxx	64/32	200000h-20FFFh	F9000h-107FFFh	SA56	110001xxx	64/32	310000h-31FFFFh	188000h-18FFFFh
SA40	100001xxx	64/32	210000h-21FFFh	108000h-10FFFFh	SA57	110010xxx	64/32	320000h-32FFFFh	190000h-197FFFh
SA41	100010xxx	64/32	220000h-22FFFh	110000h-117FFFh	SA58	110011xxx	64/32	330000h-33FFFFh	198000h-19FFFFh
SA42	101011xxx	64/32	230000h-23FFFh	118000h-11FFFFh	SA59	100100xxx	64/32	340000h-34FFFFh	1A0000h-1A7FFFh
SA43	100100xxx	64/32	240000h-24FFFh	120000h-127FFFh	SA60	110101xxx	64/32	350000h-35FFFFh	1A8000h-1AFFFFh
SA44	100101xxx	64/32	250000h-25FFFh	128000h-12FFFFh	SA61	110110xxx	64/32	360000h-36FFFFh	1B0000h-1B7FFFh
SA45	100110xxx	64/32	260000h-26FFFh	130000h-137FFFh	SA62	110111xxx	64/32	370000h-37FFFFh	1B8000h-1BFFFFh
SA46	100111xxx	64/32	270000h-27FFFh	138000h-13FFFFh	SA63	111000xxx	64/32	380000h-38FFFFh	1C0000h-1C7FFFh
SA47	101000xxx	64/32	280000h-28FFFh	140000h-147FFFh	SA64	111001xxx	64/32	390000h-39FFFFh	1C8000h-1CFFFFh
SA48	101001xxx	64/32	290000h-29FFFh	148000h-14FFFFh	SA65	111010xxx	64/32	3A0000h-3AFFFFh	1D0000h-1D7FFFh
SA49	101010xxx	64/32	2A0000h-2AFFFFh	150000h-157FFFh	SA66	111011xxx	64/32	3B0000h-3BFFFFh	1D8000h-1DFFFFh
SA50	101011xxx	64/32	2B0000h-2BFFFFh	158000h-15FFFFh	SA67	111100xxx	64/32	3C0000h-3CFFFFh	1E0000h-1E7FFFh
SA51	101100xxx	64/32	2C0000h-2CFFFFh	160000h-167FFFh	SA68	111101xxx	64/32	3D0000h-3DFFFFh	1E8000h-1EFFFFh
SA52	101101xxx	64/32	2D0000h-2DFFFFh	168000h-16FFFFh	SA69	111110xxx	64/32	3E0000h-3EFFFFh	1F0000h-1F7FFFh
SA53	101110xxx	64/32	2E0000h-2EFFFFh	170000h-177FFFh	SA70	111111xxx	64/32	3F0000h-3FFFFh	1F8000h-1FFFFh
SA54	101111xxx	64/32	2F0000h-2FFFFh	178000h-17FFFFh					

**Table 10. S29GL064A (Models RI, R2, R8, R9, WI, W2) Sector Addresses (Sheet 1 of 2)**

Sector	A21-A15	Sector Size (KB/Kwords)	8-bit Address Range	16-bit Address Range	Sector	A21-A15	Sector Size (KB/Kwords)	8-bit Address Range	16-bit Address Range
SA0	0000000	64/32	000000-00FFFF	000000-007FFF	SA37	0100101	64/32	250000-25FFFF	128000-12FFFF
SA1	0000001	64/32	010000-01FFFF	008000-00FFFF	SA38	0100110	64/32	260000-26FFFF	130000-137FFF
SA2	0000010	64/32	020000-02FFFF	010000-017FFF	SA39	0100111	64/32	270000-27FFFF	138000-13FFFF
SA3	0000011	64/32	030000-03FFFF	018000-01FFFF	SA40	0101000	64/32	280000-28FFFF	140000-147FFF
SA4	0000100	64/32	040000-04FFFF	020000-027FFF	SA41	0101001	64/32	290000-29FFFF	148000-14FFFF
SA5	0000101	64/32	050000-05FFFF	028000-02FFFF	SA42	0101010	64/32	2A0000-2AFFFF	150000-157FFF
SA6	0000110	64/32	060000-06FFFF	030000-037FFF	SA43	0101011	64/32	2B0000-2BFFFF	158000-15FFFF
SA7	0000111	64/32	070000-07FFFF	038000-03FFFF	SA44	0101100	64/32	2C0000-2CFFFF	160000-167FFF
SA8	0001000	64/32	080000-08FFFF	040000-047FFF	SA45	0101101	64/32	2D0000-2DFFFF	168000-16FFFF
SA9	0001001	64/32	090000-09FFFF	048000-04FFFF	SA46	0101110	64/32	2E0000-2EFFFF	170000-177FFF
SA10	0001010	64/32	0A0000-0AFFFF	050000-057FFF	SA47	0101111	64/32	2F0000-2FFFFF	178000-17FFFF
SA11	0001011	64/32	0B0000-0BFFFF	058000-05FFFF	SA48	0110000	64/32	300000-30FFFF	180000-187FFF
SA12	0001100	64/32	0C0000-0CFFFF	060000-067FFF	SA49	0110001	64/32	310000-31FFFF	188000-18FFFF
SA13	0001101	64/32	0D0000-0DFFFF	068000-06FFFF	SA50	0110010	64/32	320000-32FFFF	190000-197FFF
SA14	0001110	64/32	0E0000-0EFFFF	070000-077FFF	SA51	0110011	64/32	330000-33FFFF	198000-19FFFF
SA15	0001111	64/32	0F0000-0FFFFF	078000-07FFFF	SA52	0110100	64/32	340000-34FFFF	1A0000-1A7FFF
SA16	0010000	64/32	100000-10FFFF	080000-087FFF	SA53	0110101	64/32	350000-35FFFF	1A8000-1AFFFF
SA17	0010001	64/32	110000-11FFFF	088000-08FFFF	SA54	0110110	64/32	360000-36FFFF	1B0000-1B7FFF
SA18	0010010	64/32	120000-12FFFF	090000-097FFF	SA55	0110111	64/32	370000-37FFFF	1B8000-1BFFFF
SA19	0010011	64/32	130000-13FFFF	098000-09FFFF	SA56	0111000	64/32	380000-38FFFF	1C0000-1C7FFF
SA20	0010100	64/32	140000-14FFFF	0A0000-0A7FFF	SA57	0111001	64/32	390000-39FFFF	1C8000-1CFFFF
SA21	0010101	64/32	150000-15FFFF	0A8000-0AFFFF	SA58	0111010	64/32	3A0000-3AFFFF	1D0000-1D7FFF
SA22	0010110	64/32	160000-16FFFF	0B0000-0B7FFF	SA59	0111011	64/32	3B0000-3BFFFF	1D8000-1DFFFF
SA23	0010111	64/32	170000-17FFFF	0B8000-0BFFFF	SA60	0111100	64/32	3C0000-3CFFFF	1E0000-1E7FFF
SA24	0011000	64/32	180000-18FFFF	0C0000-0C7FFF	SA61	0111101	64/32	3D0000-3DFFFF	1E8000-1EFFFF
SA25	0011001	64/32	190000-19FFFF	0C8000-0CFFFF	SA62	0111110	64/32	3E0000-3EFFFF	1F0000-1F7FFF
SA26	0011010	64/32	1A0000-1AFFFF	0D0000-0D7FFF	SA63	0111111	64/32	3F0000-3FFFFF	1F8000-1FFFFF
SA27	0011011	64/32	1B0000-1BFFFF	0D8000-0DFFFF	SA64	1000000	64/32	400000-40FFFF	200000-207FFF
SA28	0011100	64/32	1C0000-1CFFFF	0E0000-0E7FFF	SA65	1000001	64/32	410000-41FFFF	208000-20FFFF
SA29	0011101	64/32	1D0000-1DFFFF	0E8000-0EFFFF	SA66	1000010	64/32	420000-42FFFF	210000-217FFF
SA30	0011110	64/32	1E0000-1EFFFF	0F0000-0F7FFF	SA67	1000011	64/32	430000-43FFFF	218000-21FFFF
SA31	0011111	64/32	1F0000-1FFFFF	0F8000-0FFFFF	SA68	1000100	64/32	440000-44FFFF	220000-227FFF
SA32	0100000	64/32	200000-20FFFF	100000-107FFF	SA69	1000101	64/32	450000-45FFFF	228000-22FFFF
SA33	0100001	64/32	210000-21FFFF	108000-10FFFF	SA70	1000110	64/32	460000-46FFFF	230000-237FFF
SA34	0100010	64/32	220000-22FFFF	110000-117FFF	SA71	1000111	64/32	470000-47FFFF	238000-23FFFF
SA35	0100011	64/32	230000-23FFFF	118000-11FFFF	SA72	1001000	64/32	480000-48FFFF	240000-247FFF
SA36	0100100	64/32	240000-24FFFF	120000-127FFF	SA73	1001001	64/32	490000-49FFFF	248000-24FFFF

Table 10. S29GL064A (Models RI, R2, R8, R9, WI, W2) Sector Addresses (Sheet 2 of 2)

Sector	A21–A15	Sector Size (KB/Kwords)	8-bit Address Range	16-bit Address Range	Sector	A21–A15	Sector Size (KB/Kwords)	8-bit Address Range	16-bit Address Range
SA74	1001010	64/32	4A0000–4AFFFF	250000–257FFF	SA101	1100101	64/32	650000–65FFFF	328000–32FFFF
SA75	1001011	64/32	4B0000–4BFFFF	258000–25FFFF	SA102	1100110	64/32	660000–66FFFF	330000–337FFF
SA76	1001100	64/32	4C0000–4CFFFF	260000–267FFF	SA103	1100111	64/32	670000–67FFFF	338000–33FFFF
SA77	1001101	64/32	4D0000–4DFFFF	268000–26FFFF	SA104	1101000	64/32	680000–68FFFF	340000–347FFF
SA78	1001110	64/32	4E0000–4EFFFF	270000–277FFF	SA105	1101001	64/32	690000–69FFFF	348000–34FFFF
SA79	1001111	64/32	4F0000–4FFFFF	278000–27FFFF	SA106	1101010	64/32	6A0000–6AFFFF	350000–357FFF
SA80	1010000	64/32	500000–50FFFF	280000–287FFF	SA107	1101011	64/32	6B0000–6BFFFF	358000–35FFFF
SA81	1010001	64/32	510000–51FFFF	288000–28FFFF	SA108	1101100	64/32	6C0000–6CFFFF	360000–367FFF
SA82	1010010	64/32	520000–52FFFF	290000–297FFF	SA109	1101101	64/32	6D0000–6DFFFF	368000–36FFFF
SA83	1010011	64/32	530000–53FFFF	298000–29FFFF	SA110	1101110	64/32	6E0000–6EFFFF	370000–377FFF
SA84	1010100	64/32	540000–54FFFF	2A0000–2A7FFF	SA111	1101111	64/32	6F0000–6FFFFF	378000–37FFFF
SA85	1010101	64/32	550000–55FFFF	2A8000–2AFFFF	SA112	1110000	64/32	700000–70FFFF	380000–387FFF
SA86	1010110	64/32	560000–56FFFF	2B0000–2B7FFF	SA113	1110001	64/32	710000–71FFFF	388000–38FFFF
SA87	1010111	64/32	570000–57FFFF	2B8000–2BFFFF	SA114	1110010	64/32	720000–72FFFF	390000–397FFF
SA88	1011000	64/32	580000–58FFFF	2C0000–2C7FFF	SA115	1110011	64/32	730000–73FFFF	398000–39FFFF
SA89	1011001	64/32	590000–59FFFF	2C8000–2CFFFF	SA116	1110100	64/32	740000–74FFFF	3A0000–3A7FFF
SA90	1011010	64/32	5A0000–5AFFFF	2D0000–2D7FFF	SA117	1110101	64/32	750000–75FFFF	3A8000–3AFFFF
SA91	1011011	64/32	5B0000–5BFFFF	2D8000–2DFFFF	SA118	1110110	64/32	760000–76FFFF	3B0000–3B7FFF
SA92	1011100	64/32	5C0000–5CFFFF	2E0000–2E7FFF	SA119	1110111	64/32	770000–77FFFF	3B8000–3BFFFF
SA93	1011101	64/32	5D0000–5DFFFF	2E8000–2EFFFF	SA120	1111000	64/32	780000–78FFFF	3C0000–3C7FFF
SA94	1011110	64/32	5E0000–5EFFFF	2F0000–2F7FFF	SA121	1111001	64/32	790000–79FFFF	3C8000–3CFFFF
SA95	1011111	64/32	5F0000–5FFFFF	2F8000–2FFFFF	SA122	1111010	64/32	7A0000–7AFFFF	3D0000–3D7FFF
SA96	1100000	64/32	600000–60FFFF	300000–307FFF	SA123	1111011	64/32	7B0000–7BFFFF	3D8000–3DFFFF
SA97	1100001	64/32	610000–61FFFF	308000–30FFFF	SA124	1111100	64/32	7C0000–7CFFFF	3E0000–3E7FFF
SA98	1100010	64/32	620000–62FFFF	310000–317FFF	SA125	1111101	64/32	7D0000–7DFFFF	3E8000–3EFFFF
SA99	1100011	64/32	630000–63FFFF	318000–31FFFF	SA126	1111110	64/32	7E0000–7EFFFF	3F0000–3F7FFF
SA100	1100100	64/32	640000–64FFFF	320000–327FFF	SA127	1111111	64/32	7F0000–7FFFFF	3F8000–3FFFFF

**Table II. S29GL064A (Model R3, W3)  
Top Boot Sector Addresses (Sheet 1 of 2)**

Sector	A21-A12	Sector Size (KB/Kwords)	8-bit Address Range	16-bit Address Range	Sector	A21-A12	Sector Size (KB/Kwords)	8-bit Address Range	16-bit Address Range
SA0	000000xxx	64/32	000000h-00FFFFh	00000h-07FFFh	SA34	0100010xxx	64/32	220000h-22FFFFh	110000h-117FFFh
SA1	0000001xxx	64/32	010000h-01FFFFh	08000h-0FFFFh	SA35	0101011xxx	64/32	230000h-23FFFFh	118000h-11FFFFh
SA2	0000010xxx	64/32	020000h-02FFFFh	10000h-17FFFh	SA36	0100100xxx	64/32	240000h-24FFFFh	120000h-127FFFh
SA3	0000011xxx	64/32	030000h-03FFFFh	18000h-1FFFFh	SA37	0100101xxx	64/32	250000h-25FFFFh	128000h-12FFFFh
SA4	0000100xxx	64/32	040000h-04FFFFh	20000h-27FFFh	SA38	0100110xxx	64/32	260000h-26FFFFh	130000h-137FFFh
SA5	0000101xxx	64/32	050000h-05FFFFh	28000h-2FFFFh	SA39	0100111xxx	64/32	270000h-27FFFFh	138000h-13FFFFh
SA6	0000110xxx	64/32	060000h-06FFFFh	30000h-37FFFh	SA40	0101000xxx	64/32	280000h-28FFFFh	140000h-147FFFh
SA7	0000111xxx	64/32	070000h-07FFFFh	38000h-3FFFFh	SA41	0101001xxx	64/32	290000h-29FFFFh	148000h-14FFFFh
SA8	0001000xxx	64/32	080000h-08FFFFh	40000h-47FFFh	SA42	0101010xxx	64/32	2A0000h-2AFFFFh	150000h-157FFFh
SA9	0001001xxx	64/32	090000h-09FFFFh	48000h-4FFFFh	SA43	0101011xxx	64/32	2B0000h-2BFFFFh	158000h-15FFFFh
SA10	0001010xxx	64/32	0A0000h-0AFFFFh	50000h-57FFFh	SA44	0101100xxx	64/32	2C0000h-2CFFFFh	160000h-167FFFh
SA11	0001011xxx	64/32	0B0000h-0BFFFFh	58000h-5FFFFh	SA45	0101101xxx	64/32	2D0000h-2DFFFFh	168000h-16FFFFh
SA12	0001100xxx	64/32	0C0000h-0CFFFFh	60000h-67FFFh	SA46	0101110xxx	64/32	2E0000h-2EFFFFh	170000h-177FFFh
SA13	0001101xxx	64/32	0D0000h-0DFFFFh	68000h-6FFFFh	SA47	0101111xxx	64/32	2F0000h-2FFFFFh	178000h-17FFFFh
SA14	0001101xxx	64/32	0E0000h-0EFFFFh	70000h-77FFFh	SA48	0110000xxx	64/32	300000h-30FFFFh	180000h-187FFFh
SA15	0001111xxx	64/32	0F0000h-0FFFFFh	78000h-7FFFFh	SA49	0110001xxx	64/32	310000h-31FFFFh	188000h-18FFFFh
SA16	0010000xxx	64/32	100000h-00FFFFh	80000h-87FFFh	SA50	0110010xxx	64/32	320000h-32FFFFh	190000h-197FFFh
SA17	0010001xxx	64/32	110000h-11FFFFh	88000h-8FFFFh	SA51	0110011xxx	64/32	330000h-33FFFFh	198000h-19FFFFh
SA18	0010010xxx	64/32	120000h-12FFFFh	90000h-97FFFh	SA52	0100100xxx	64/32	340000h-34FFFFh	1A0000h-1A7FFFh
SA19	0010011xxx	64/32	130000h-13FFFFh	98000h-9FFFFh	SA53	0110101xxx	64/32	350000h-35FFFFh	1A8000h-1AFFFFh
SA20	0010100xxx	64/32	140000h-14FFFFh	A0000h-A7FFFh	SA54	0110110xxx	64/32	360000h-36FFFFh	1B0000h-1B7FFFh
SA21	0010101xxx	64/32	150000h-15FFFFh	A8000h-AFFFFh	SA55	0110111xxx	64/32	370000h-37FFFFh	1B8000h-1BFFFFh
SA22	0010110xxx	64/32	160000h-16FFFFh	B0000h-B7FFFh	SA56	0111000xxx	64/32	380000h-38FFFFh	1C0000h-1C7FFFh
SA23	0010111xxx	64/32	170000h-17FFFFh	B8000h-BFFFFh	SA57	0111001xxx	64/32	390000h-39FFFFh	1C8000h-1CFFFFh
SA24	0011000xxx	64/32	180000h-18FFFFh	C0000h-C7FFFh	SA58	0111010xxx	64/32	3A0000h-3AFFFFh	1D0000h-1D7FFFh
SA25	0011001xxx	64/32	190000h-19FFFFh	C8000h-CFFFFh	SA59	0111011xxx	64/32	3B0000h-3BFFFFh	1D8000h-1DFFFFh
SA26	0011010xxx	64/32	1A0000h-1AFFFFh	D0000h-D7FFFh	SA60	0111100xxx	64/32	3C0000h-3CFFFFh	1E0000h-1E7FFFh
SA27	0011011xxx	64/32	1B0000h-1BFFFFh	D8000h-DFFFFh	SA61	0111101xxx	64/32	3D0000h-3DFFFFh	1E8000h-1EFFFFh
SA28	0011000xxx	64/32	1C0000h-1CFFFFh	E0000h-E7FFFh	SA62	0111110xxx	64/32	3E0000h-3EFFFFh	1F0000h-1F7FFFh
SA29	0011101xxx	64/32	1D0000h-1DFFFFh	E8000h-EFFFFh	SA63	0111111xxx	64/32	3F0000h-3FFFFFh	1F8000h-1FFFFFh
SA30	0011110xxx	64/32	1E0000h-1EFFFFh	F0000h-F7FFFh	SA64	1000000xxx	64/32	400000h-40FFFFh	200000h-207FFFh
SA31	0011111xxx	64/32	1F0000h-1FFFFFh	F8000h-FFFFFh	SA65	1000001xxx	64/32	410000h-41FFFFh	208000h-20FFFFh
SA32	0100000xxx	64/32	200000h-20FFFFh	F9000h-107FFFh	SA66	1000010xxx	64/32	420000h-42FFFFh	210000h-217FFFh
SA33	0100001xxx	64/32	210000h-21FFFFh	108000h-10FFFFh	SA67	1000011xxx	64/32	430000h-43FFFFh	218000h-21FFFFh
SA68	1000100xxx	64/32	440000h-44FFFFh	220000h-227FFFh	SA102	1100110xxx	64/32	660000h-66FFFFh	330000h-337FFFh
SA69	1000101xxx	64/32	450000h-45FFFFh	228000h-22FFFFh	SA103	1100111xxx	64/32	670000h-67FFFFh	338000h-33FFFFh
SA70	1000110xxx	64/32	460000h-46FFFFh	230000h-237FFFh	SA104	1101000xxx	64/32	680000h-68FFFFh	340000h-347FFFh
SA71	1000111xxx	64/32	470000h-47FFFFh	238000h-23FFFFh	SA105	1101001xxx	64/32	690000h-69FFFFh	348000h-34FFFFh
SA72	1001000xxx	64/32	480000h-48FFFFh	240000h-247FFFh	SA106	1101010xxx	64/32	6A0000h-6AFFFFh	350000h-357FFFh
SA73	1001001xxx	64/32	490000h-49FFFFh	248000h-24FFFFh	SA107	1101011xxx	64/32	6B0000h-6BFFFFh	358000h-35FFFFh
SA74	1001010xxx	64/32	4A0000h-4AFFFFh	250000h-257FFFh	SA108	1101100xxx	64/32	6C0000h-6CFFFFh	360000h-367FFFh



**Table II. S29GL064A (Model R3, W3)  
Top Boot Sector Addresses (Sheet 2 of 2)**

Sector	A21-A12	Sector Size (KB/Kwords)	8-bit Address Range	16-bit Address Range	Sector	A21-A12	Sector Size (KB/Kwords)	8-bit Address Range	16-bit Address Range
SA75	1001011xxx	64/32	4B0000h-4BFFFFh	258000h-25FFFFh	SA109	1101101xxx	64/32	6D0000h-6DFFFFh	368000h-36FFFFh
SA76	1001100xxx	64/32	4C0000h-4CFFFFh	260000h-267FFFh	SA110	1101110xxx	64/32	6E0000h-6EFFFFh	370000h-377FFFh
SA77	1001101xxx	64/32	4D0000h-4DFFFFh	268000h-26FFFFh	SA111	1101111xxx	64/32	6F0000h-6FFFFFh	378000h-37FFFFh
SA78	1001110xxx	64/32	4E0000h-4EFFFFh	270000h-277FFFh	SA112	1110000xxx	64/32	700000h-70FFFFh	380000h-387FFFh
SA79	1001111xxx	64/32	4F0000h-4FFFFFh	278000h-27FFFFh	SA113	1110001xxx	64/32	710000h-71FFFFh	388000h-38FFFFh
SA80	1010000xxx	64/32	500000h-50FFFFh	280000h-28FFFFh	SA114	1110010xxx	64/32	720000h-72FFFFh	390000h-397FFFh
SA81	1010001xxx	64/32	510000h-51FFFFh	288000h-28FFFFh	SA115	1110011xxx	64/32	730000h-73FFFFh	398000h-39FFFFh
SA82	1010010xxx	64/32	520000h-52FFFFh	290000h-297FFFh	SA116	1110100xxx	64/32	740000h-74FFFFh	3A0000h-3A7FFFh
SA83	1010011xxx	64/32	530000h-53FFFFh	298000h-29FFFFh	SA117	1110101xxx	64/32	750000h-75FFFFh	3A8000h-3AFFFFh
SA84	1010100xxx	64/32	540000h-54FFFFh	2A0000h-2A7FFFh	SA118	1110110xxx	64/32	760000h-76FFFFh	3B0000h-3B7FFFh
SA85	1010101xxx	64/32	550000h-55FFFFh	2A8000h-2AFFFFh	SA119	1110111xxx	64/32	770000h-77FFFFh	3B8000h-3BFFFFh
SA86	1010110xxx	64/32	560000h-56FFFFh	2B0000h-2B7FFFh	SA120	1111000xxx	64/32	780000h-78FFFFh	3C0000h-3C7FFFh
SA87	1010111xxx	64/32	570000h-57FFFFh	2B8000h-2BFFFFh	SA121	1111001xxx	64/32	790000h-79FFFFh	3C8000h-3CFFFFh
SA88	1011000xxx	64/32	580000h-58FFFFh	2C0000h-2C7FFFh	SA122	1111010xxx	64/32	7A0000h-7AFFFFh	3D0000h-3D7FFFh
SA89	1011001xxx	64/32	590000h-59FFFFh	2C8000h-2CFFFFh	SA123	1111011xxx	64/32	7B0000h-7BFFFFh	3D8000h-3DFFFFh
SA90	1011010xxx	64/32	5A0000h-5AFFFFh	2D0000h-2D7FFFh	SA124	1111100xxx	64/32	7C0000h-7CFFFFh	3E0000h-3E7FFFh
SA91	1011011xxx	64/32	5B0000h-5BFFFFh	2D8000h-2DFFFFh	SA125	1111101xxx	64/32	7D0000h-7DFFFFh	3E8000h-3EFFFFh
SA92	1011100xxx	64/32	5C0000h-5CFFFFh	2E0000h-2E7FFFh	SA126	1111110xxx	64/32	7E0000h-7EFFFFh	3F0000h-3F7FFFh
SA93	1011101xxx	64/32	5D0000h-5DFFFFh	2E8000h-2EFFFFh	SA127	1111111000	8/4	7F0000h-7F1FFFh	3F8000h-3F8FFFh
SA94	1011110xxx	64/32	5E0000h-5EFFFFh	2F0000h-2F7FFFh	SA128	1111111001	8/4	7F2000h-7F3FFFh	3F9000h-3F9FFFh
SA95	1011111xxx	64/32	5F0000h-5FFFFFh	2F8000h-2F7FFFh	SA129	1111111010	8/4	7F4000h-7F5FFFh	3FA000h-3FAFFFh
SA96	1100000xxx	64/32	600000h-60FFFFh	300000h-307FFFh	SA130	1111111011	8/4	7F6000h-7F7FFFh	3FB000h-3FBFFFh
SA97	1100001xxx	64/32	610000h-61FFFFh	308000h-30FFFFh	SA131	1111111100	8/4	7F8000h-7F9FFFh	3FC000h-3FCFFFh
SA98	1100010xxx	64/32	620000h-62FFFFh	310000h-317FFFh	SA132	1111111101	8/4	7FA000h-7FBFFFh	3FD000h-3FDFFFh
SA99	1100011xxx	64/32	630000h-63FFFFh	318000h-31FFFFh	SA133	1111111110	8/4	7FC000h-7FDFFFh	3FE000h-3FEFFFh
SA100	1100100xxx	64/32	640000h-64FFFFh	320000h-327FFFh	SA134	1111111111	8/4	7FE000h-7FFFFFh	3FF000h-3FFFFFh
SA101	1100101xxx	64/32	650000h-65FFFFh	328000h-32FFFFh					

**Table I2. S29GL064A (Model R4, W4) B  
Bottom Boot Sector Addresses (Sheet I of 2)**

Sector	A21–A12	Sector Size (KB/Kwords)	8-bit Address Range	16-bit Address Range	Sector	A21–A12	Sector Size (KB/Kwords)	8-bit Address Range	16-bit Address Range
SA0	000000000	8/4	000000h–001FFFh	00000h–00FFFh	SA27	0010100xxx	64/32	140000h–14FFFFh	A0000h–A7FFFh
SA1	000000001	8/4	002000h–003FFFh	01000h–01FFFh	SA28	0010101xxx	64/32	150000h–15FFFFh	A8000h–AFFFFh
SA2	000000010	8/4	004000h–005FFFh	02000h–02FFFh	SA29	0010110xxx	64/32	160000h–16FFFFh	B0000h–B7FFFh
SA3	000000011	8/4	006000h–007FFFh	03000h–03FFFh	SA30	0010111xxx	64/32	170000h–17FFFFh	B8000h–BFFFFh
SA4	000000100	8/4	008000h–009FFFh	04000h–04FFFh	SA31	0011000xxx	64/32	180000h–18FFFFh	C0000h–C7FFFh
SA5	000000101	8/4	00A000h–00BFFFh	05000h–05FFFh	SA32	0011001xxx	64/32	190000h–19FFFFh	C8000h–CFFFFh
SA6	000000110	8/4	00C000h–00DFFFh	06000h–06FFFh	SA33	0011010xxx	64/32	1A0000h–1AFFFFh	D0000h–D7FFFh
SA7	000000111	8/4	00E000h–00FFFFh	07000h–07FFFh	SA34	0011011xxx	64/32	1B0000h–1BFFFFh	D8000h–DFFFFh
SA8	000001xxx	64/32	010000h–01FFFh	08000h–0FFFFh	SA35	0011000xxx	64/32	1C0000h–1CFFFFh	E0000h–E7FFFh
SA9	000010xxx	64/32	020000h–02FFFh	10000h–17FFFh	SA36	0011101xxx	64/32	1D0000h–1DFFFFh	E8000h–EFFFFh
SA10	000011xxx	64/32	030000h–03FFFh	18000h–1FFFFh	SA37	0011110xxx	64/32	1E0000h–1EFFFFh	F0000h–F7FFFh
SA11	0000100xxx	64/32	040000h–04FFFh	20000h–27FFFh	SA38	0011111xxx	64/32	1F0000h–1FFFFh	F8000h–FFFFh
SA12	0000101xxx	64/32	050000h–05FFFh	28000h–2FFFFh	SA39	0100000xxx	64/32	200000h–20FFFFh	F9000h–107FFFh
SA13	0000110xxx	64/32	060000h–06FFFh	30000h–37FFFh	SA40	0100001xxx	64/32	210000h–21FFFFh	108000h–10FFFFh
SA14	0000111xxx	64/32	070000h–07FFFh	38000h–3FFFFh	SA41	0100010xxx	64/32	220000h–22FFFFh	110000h–117FFFh
SA15	0001000xxx	64/32	080000h–08FFFh	40000h–47FFFh	SA42	0101011xxx	64/32	230000h–23FFFFh	118000h–11FFFFh
SA16	0001001xxx	64/32	090000h–09FFFh	48000h–4FFFFh	SA43	0100100xxx	64/32	240000h–24FFFFh	120000h–127FFFh
SA17	0001010xxx	64/32	0A0000h–0AFFFFh	50000h–57FFFh	SA44	0100101xxx	64/32	250000h–25FFFFh	128000h–12FFFFh
SA18	0001011xxx	64/32	0B0000h–0BFFFFh	58000h–5FFFFh	SA45	0100110xxx	64/32	260000h–26FFFFh	130000h–137FFFh
SA19	0001100xxx	64/32	0C0000h–0CFFFFh	60000h–67FFFh	SA46	0100111xxx	64/32	270000h–27FFFFh	138000h–13FFFFh
SA20	0001101xxx	64/32	0D0000h–0DFFFFh	68000h–6FFFFh	SA47	0101000xxx	64/32	280000h–28FFFFh	140000h–147FFFh
SA21	0001101xxx	64/32	0E0000h–0EFFFFh	70000h–77FFFh	SA48	0101001xxx	64/32	290000h–29FFFFh	148000h–14FFFFh
SA22	0001111xxx	64/32	0F0000h–0FFFFh	78000h–7FFFFh	SA49	0101010xxx	64/32	2A0000h–2AFFFFh	150000h–157FFFh
SA23	0010000xxx	64/32	100000h–00FFFh	80000h–87FFFh	SA50	0101011xxx	64/32	2B0000h–2BFFFFh	158000h–15FFFFh
SA24	0010001xxx	64/32	110000h–11FFFh	88000h–8FFFFh	SA51	0101100xxx	64/32	2C0000h–2CFFFFh	160000h–167FFFh
SA25	0010010xxx	64/32	120000h–12FFFh	90000h–97FFFh	SA52	0101101xxx	64/32	2D0000h–2DFFFFh	168000h–16FFFFh
SA26	0010011xxx	64/32	130000h–13FFFh	98000h–9FFFFh	SA53	0101110xxx	64/32	2E0000h–2EFFFFh	170000h–177FFFh
SA54	0101111xxx	64/32	2F0000h–2FFFFh	178000h–17FFFFh	SA95	1011000xxx	64/32	580000h–58FFFFh	2C0000h–2C7FFFh
SA55	0110000xxx	64/32	300000h–30FFFh	180000h–187FFFh	SA96	1011001xxx	64/32	590000h–59FFFFh	2C8000h–2CFFFFh
SA56	0110001xxx	64/32	310000h–31FFFh	188000h–18FFFFh	SA97	1011010xxx	64/32	5A0000h–5AFFFFh	2D0000h–2D7FFFh
SA57	0110010xxx	64/32	320000h–32FFFh	190000h–197FFFh	SA98	1011011xxx	64/32	5B0000h–5BFFFFh	2D8000h–2DFFFFh
SA58	0110011xxx	64/32	330000h–33FFFh	198000h–19FFFFh	SA99	1011100xxx	64/32	5C0000h–5CFFFFh	2E0000h–2E7FFFh
SA59	0100100xxx	64/32	340000h–34FFFh	1A0000h–1A7FFFh	SA100	1011101xxx	64/32	5D0000h–5DFFFFh	2E8000h–2EFFFFh
SA60	0110101xxx	64/32	350000h–35FFFh	1A8000h–1AFFFFh	SA101	1011110xxx	64/32	5E0000h–5EFFFFh	2F0000h–2FFFFh
SA61	0110110xxx	64/32	360000h–36FFFh	1B0000h–1B7FFFh	SA102	1011111xxx	64/32	5F0000h–5FFFFh	2F8000h–2FFFFh
SA62	0110111xxx	64/32	370000h–37FFFh	1B8000h–1BFFFFh	SA103	1100000xxx	64/32	600000h–60FFFFh	300000h–307FFFh
SA63	0111000xxx	64/32	380000h–38FFFh	1C0000h–1C7FFFh	SA104	1100001xxx	64/32	610000h–61FFFFh	308000h–30FFFFh
SA64	0111001xxx	64/32	390000h–39FFFh	1C8000h–1CFFFFh	SA105	1100010xxx	64/32	620000h–62FFFFh	310000h–317FFFh
SA65	0111010xxx	64/32	3A0000h–3AFFFFh	1D0000h–1D7FFFh	SA106	1100011xxx	64/32	630000h–63FFFFh	318000h–31FFFFh
SA66	0111011xxx	64/32	3B0000h–3BFFFFh	1D8000h–1DFFFFh	SA107	1100100xxx	64/32	640000h–64FFFFh	320000h–327FFFh
SA67	0111100xxx	64/32	3C0000h–3CFFFFh	1E0000h–1E7FFFh	SA108	1100101xxx	64/32	650000h–65FFFFh	328000h–32FFFFh
SA68	0111101xxx	64/32	3D0000h–3DFFFFh	1E8000h–1EFFFFh	SA109	1100110xxx	64/32	660000h–66FFFFh	330000h–337FFFh
SA69	0111110xxx	64/32	3E0000h–3EFFFFh	1F0000h–1F7FFFh	SA110	1100111xxx	64/32	670000h–67FFFFh	338000h–33FFFFh

**Table I2. S29GL064A (Model R4, W4) B  
ottom Boot Sector Addresses (Sheet 2 of 2)**

Sector	A21–A12	Sector Size (KB/Kwords)	8-bit Address Range	16-bit Address Range	Sector	A21–A12	Sector Size (KB/Kwords)	8-bit Address Range	16-bit Address Range
SA70	0111111xxx	64/32	3F0000h–3FFFFFFh	1F8000h–1FFFFFFh	SA111	1101000xxx	64/32	680000h–68FFFFFFh	340000h–347FFFh
SA71	1000000xxx	64/32	400000h–40FFFFFFh	200000h–207FFFh	SA112	1101001xxx	64/32	690000h–69FFFFFFh	348000h–34FFFFFFh
SA72	1000001xxx	64/32	410000h–41FFFFFFh	208000h–20FFFFFFh	SA113	1101010xxx	64/32	6A0000h–6AFFFFFFh	350000h–357FFFh
SA73	1000010xxx	64/32	420000h–42FFFFFFh	210000h–217FFFh	SA114	1101011xxx	64/32	6B0000h–6BFFFFFFh	358000h–35FFFFFFh
SA74	1000011xxx	64/32	430000h–43FFFFFFh	218000h–21FFFFFFh	SA115	1101100xxx	64/32	6C0000h–6CFFFFFFh	360000h–367FFFh
SA75	1000100xxx	64/32	440000h–44FFFFFFh	220000h–227FFFh	SA116	1101101xxx	64/32	6D0000h–6DFFFFFFh	368000h–36FFFFFFh
SA76	1000101xxx	64/32	450000h–45FFFFFFh	228000h–22FFFFFFh	SA117	1101110xxx	64/32	6E0000h–6EFFFFFFh	370000h–377FFFh
SA77	1000110xxx	64/32	460000h–46FFFFFFh	230000h–237FFFh	SA118	1101111xxx	64/32	6F0000h–6FFFFFFh	378000h–37FFFFFFh
SA78	1000111xxx	64/32	470000h–47FFFFFFh	238000h–23FFFFFFh	SA119	1110000xxx	64/32	700000h–70FFFFFFh	380000h–387FFFh
SA79	1001000xxx	64/32	480000h–48FFFFFFh	240000h–247FFFh	SA120	1110001xxx	64/32	710000h–71FFFFFFh	388000h–38FFFFFFh
SA80	1001001xxx	64/32	490000h–49FFFFFFh	248000h–24FFFFFFh	SA121	1110010xxx	64/32	720000h–72FFFFFFh	390000h–397FFFh
SA81	1001010xxx	64/32	4A0000h–4AFFFFFFh	250000h–257FFFh	SA122	1110011xxx	64/32	730000h–73FFFFFFh	398000h–39FFFFFFh
SA82	1001011xxx	64/32	4B0000h–4BFFFFFFh	258000h–25FFFFFFh	SA123	1110100xxx	64/32	740000h–74FFFFFFh	3A0000h–3A7FFFh
SA83	1001100xxx	64/32	4C0000h–4CFFFFFFh	260000h–267FFFh	SA124	1110101xxx	64/32	750000h–75FFFFFFh	3A8000h–3AFFFFFFh
SA84	1001101xxx	64/32	4D0000h–4DFFFFFFh	268000h–26FFFFFFh	SA125	1110110xxx	64/32	760000h–76FFFFFFh	3B0000h–3B7FFFh
SA85	1001110xxx	64/32	4E0000h–4EFFFFFFh	270000h–277FFFh	SA126	1110111xxx	64/32	770000h–77FFFFFFh	3B8000h–3BFFFFFFh
SA86	1001111xxx	64/32	4F0000h–4FFFFFFh	278000h–27FFFFFFh	SA127	1111000xxx	64/32	780000h–78FFFFFFh	3C0000h–3C7FFFh
SA87	1010000xxx	64/32	500000h–50FFFFFFh	280000h–287FFFh	SA128	1111001xxx	64/32	790000h–79FFFFFFh	3C8000h–3CFFFFFFh
SA88	1010001xxx	64/32	510000h–51FFFFFFh	288000h–28FFFFFFh	SA129	1111010xxx	64/32	7A0000h–7AFFFFFFh	3D0000h–3D7FFFh
SA89	1010010xxx	64/32	520000h–52FFFFFFh	290000h–297FFFh	SA130	1111011xxx	64/32	7B0000h–7BFFFFFFh	3D8000h–3DFFFFFFh
SA90	1010011xxx	64/32	530000h–53FFFFFFh	298000h–29FFFFFFh	SA131	1111100xxx	64/32	7C0000h–7CFFFFFFh	3E0000h–3E7FFFh
SA91	1010100xxx	64/32	540000h–54FFFFFFh	2A0000h–2A7FFFh	SA132	1111101xxx	64/32	7D0000h–7DFFFFFFh	3E8000h–3EFFFFFFh
SA92	1010101xxx	64/32	550000h–55FFFFFFh	2A8000h–2AFFFFFFh	SA133	1111110xxx	64/32	7E0000h–7EFFFFFFh	3F0000h–3F7FFFh
SA93	1010110xxx	64/32	560000h–56FFFFFFh	2B0000h–2B7FFFh	SA134	1111111000	64/32	7F0000h–7FFFFFFh	3F8000h–3FFFFFFh
SA94	1010111xxx	64/32	570000h–57FFFFFFh	2B8000h–2BFFFFFFh					

**Table 13. S29GL064A (Model R5) Sector Addresses (Sheet 1 of 2)**

Sector	A21–A15	16-bit Address Range	Sector	A21–A15	16-bit Address Range
SA0	0000000	000000–007FFF	SA21	0010101	0A8000–0AFFFF
SA1	0000001	008000–00FFFF	SA22	0010110	0B0000–0B7FFF
SA2	0000010	010000–017FFF	SA23	0010111	0B8000–0BF7FF
SA3	0000011	018000–01FFFF	SA24	0011000	0C0000–0C7FFF
SA4	0000100	020000–027FFF	SA25	0011001	0C8000–0CF7FF
SA5	0000101	028000–02FFFF	SA26	0011010	0D0000–0D7FFF
SA6	0000110	030000–037FFF	SA27	0011011	0D8000–0DF7FF
SA7	0000111	038000–03FFFF	SA28	0011100	0E0000–0E7FFF
SA8	0001000	040000–047FFF	SA29	0011101	0E8000–0EF7FF
SA9	0001001	048000–04FFFF	SA30	0011110	0F0000–0F7FFF
SA10	0001010	050000–057FFF	SA31	0011111	0F8000–0FF7FF
SA11	0001011	058000–05FFFF	SA32	0100000	200000–207FFF
SA12	0001100	060000–067FFF	SA33	0100001	208000–20FFFF
SA13	0001101	068000–06FFFF	SA34	0100010	210000–217FFF
SA14	0001110	070000–077FFF	SA35	0100011	218000–21FFFF
SA15	0001111	078000–07FFFF	SA36	0100100	220000–227FFF
SA16	0010000	080000–087FFF	SA37	0100101	228000–22FFFF
SA17	0010001	088000–08FFFF	SA38	0100110	230000–237FFF
SA18	0010010	090000–097FFF	SA39	0100111	238000–23FFFF
SA19	0010011	098000–09FFFF	SA40	0101000	240000–247FFF
SA20	0010100	0A0000–0A7FFF	SA41	0101001	248000–24FFFF
SA42	0101010	250000–257FFF	SA85	1010101	1A8000–1AFFFF
SA43	0101011	258000–25FFFF	SA86	1010110	1B0000–1B7FFF
SA44	0101100	260000–267FFF	SA87	1010111	1B8000–1BF7FF
SA45	0101101	268000–26FFFF	SA88	1011000	1C0000–1C7FFF
SA46	0101110	270000–277FFF	SA89	1011001	1C8000–1CF7FF
SA47	0101111	278000–27FFFF	SA90	1011010	1D0000–1D7FFF
SA48	0110000	280000–287FFF	SA91	1011011	1D8000–1DF7FF
SA49	0110001	288000–28FFFF	SA92	1011100	1E0000–1E7FFF
SA50	0110010	290000–297FFF	SA93	1011101	1E8000–1EF7FF
SA51	0110011	298000–29FFFF	SA94	1011110	1F0000–1F7FFF
SA52	0110100	2A0000–2A7FFF	SA95	1011111	1F8000–1FF7FF
SA53	0110101	2A8000–2AFFFF	SA96	1100000	300000–307FFF
SA54	0110110	2B0000–2B7FFF	SA97	1100001	308000–30FFFF
SA55	0110111	2B8000–2BF7FF	SA98	1100010	310000–317FFF
SA56	0111000	2C0000–2C7FFF	SA99	1100011	318000–31FFFF
SA57	0111001	2C8000–2CF7FF	SA100	1100100	320000–327FFF
SA58	0111010	2D0000–2D7FFF	SA101	1100101	328000–32FFFF
SA59	0111011	2D8000–2DF7FF	SA102	1100110	330000–337FFF
SA60	0111100	2E0000–2E7FFF	SA103	1100111	338000–33FFFF
SA61	0111101	2E8000–2EF7FF	SA104	1101000	340000–347FFF
SA62	0111110	2F0000–2F7FFF	SA105	1101001	348000–34FFFF
SA63	0111111	2F8000–2FFFFF	SA106	1101010	350000–357FFF
SA64	1000000	100000–107FFF	SA107	1101011	358000–35FFFF
SA65	1000001	108000–10FFFF	SA108	1101100	360000–367FFF
SA66	1000010	110000–117FFF	SA109	1101101	368000–36FFFF

Table I3. S29GL064A (Model R5) Sector Addresses (Sheet 2 of 2)

Sector	A21–A15	16-bit Address Range	Sector	A21–A15	16-bit Address Range
SA67	1000011	118000–11FFFF	SA110	1101110	370000–377FFF
SA68	1000100	120000–127FFF	SA111	1101111	378000–37FFFF
SA69	1000101	128000–12FFFF	SA112	1110000	380000–387FFF
SA70	1000110	130000–137FFF	SA113	1110001	388000–38FFFF
SA71	1000111	138000–13FFFF	SA114	1110010	390000–397FFF
SA72	1001000	140000–147FFF	SA115	1110011	398000–39FFFF
SA73	1001001	148000–14FFFF	SA116	1110100	3A0000–3A7FFF
SA74	1001010	150000–157FFF	SA117	1110101	3A8000–3AFFFF
SA75	1001011	158000–15FFFF	SA118	1110110	3B0000–3B7FFF
SA76	1001100	160000–167FFF	SA119	1110111	3B8000–3BFFFF
SA77	1001101	168000–16FFFF	SA120	1111000	3C0000–3C7FFF
SA78	1001110	170000–177FFF	SA121	1111001	3C8000–3CFFFF
SA79	1001111	178000–17FFFF	SA122	1111010	3D0000–3D7FFF
SA80	1010000	180000–187FFF	SA123	1111011	3D8000–3DFFFF
SA81	1010001	188000–18FFFF	SA124	1111100	3E0000–3E7FFF
SA82	1010010	190000–197FFF	SA125	1111101	3E8000–3EFFFF
SA83	1010011	198000–19FFFF	SA126	1111110	3F0000–3F7FFF
SA84	1010100	1A0000–1A7FFF	SA127	1111111	3F8000–3FFFFF

**Table I4. S29GL064A (Models R6, R7) Sector Addresses (Sheet 1 of 2)**

Sector	A21–A15	16-bit Address Range	Sector	A21–A15	16-bit Address Range
SA0	0000000	000000–007FFF	SA21	0010101	0A8000–0AFFFF
SA1	0000001	008000–00FFFF	SA22	0010110	0B0000–0B7FFF
SA2	0000010	010000–017FFF	SA23	0010111	0B8000–0BFFFF
SA3	0000011	018000–01FFFF	SA24	0011000	0C0000–0C7FFF
SA4	0000100	020000–027FFF	SA25	0011001	0C8000–0CFFFF
SA5	0000101	028000–02FFFF	SA26	0011010	0D0000–0D7FFF
SA6	0000110	030000–037FFF	SA27	0011011	0D8000–0DFFFF
SA7	0000111	038000–03FFFF	SA28	0011100	0E0000–0E7FFF
SA8	0001000	040000–047FFF	SA29	0011101	0E8000–0EFFFF
SA9	0001001	048000–04FFFF	SA30	0011110	0F0000–0F7FFF
SA10	0001010	050000–057FFF	SA31	0011111	0F8000–0FFFFF
SA11	0001011	058000–05FFFF	SA32	0100000	200000–207FFF
SA12	0001100	060000–067FFF	SA33	0100001	208000–20FFFF
SA13	0001101	068000–06FFFF	SA34	0100010	210000–217FFF
SA14	0001110	070000–077FFF	SA35	0100011	218000–21FFFF
SA15	0001111	078000–07FFFF	SA36	0100100	220000–227FFF
SA16	0010000	080000–087FFF	SA37	0100101	228000–22FFFF
SA17	0010001	088000–08FFFF	SA38	0100110	230000–237FFF
SA18	0010010	090000–097FFF	SA39	0100111	238000–23FFFF
SA19	0010011	098000–09FFFF	SA40	0101000	240000–247FFF
SA20	0010100	0A0000–0A7FFF	SA41	0101001	248000–24FFFF
SA42	0101010	250000–257FFF	SA85	1010101	1A8000–1AFFFF
SA43	0101011	258000–25FFFF	SA86	1010110	1B0000–1B7FFF
SA44	0101100	260000–267FFF	SA87	1010111	1B8000–1BFFFF
SA45	0101101	268000–26FFFF	SA88	1011000	1C0000–1C7FFF
SA46	0101110	270000–277FFF	SA89	1011001	1C8000–1CFFFF
SA47	0101111	278000–27FFFF	SA90	1011010	1D0000–1D7FFF
SA48	0110000	280000–287FFF	SA91	1011011	1D8000–1DFFFF
SA49	0110001	288000–28FFFF	SA92	1011100	1E0000–1E7FFF
SA50	0110010	290000–297FFF	SA93	1011101	1E8000–1EFFFF
SA51	0110011	298000–29FFFF	SA94	1011110	1F0000–1F7FFF
SA52	0110100	2A0000–2A7FFF	SA95	1011111	1F8000–1FFFFF
SA53	0110101	2A8000–2AFFFF	SA96	1100000	300000–307FFF
SA54	0110110	2B0000–2B7FFF	SA97	1100001	308000–30FFFF
SA55	0110111	2B8000–2BFFFF	SA98	1100010	310000–317FFF
SA56	0111000	2C0000–2C7FFF	SA99	1100011	318000–31FFFF
SA57	0111001	2C8000–2CFFFF	SA100	1100100	320000–327FFF
SA58	0111010	2D0000–2D7FFF	SA101	1100101	328000–32FFFF
SA59	0111011	2D8000–2DFFFF	SA102	1100110	330000–337FFF
SA60	0111100	2E0000–2E7FFF	SA103	1100111	338000–33FFFF
SA61	0111101	2E8000–2EFFFF	SA104	1101000	340000–347FFF
SA62	0111110	2F0000–2F7FFF	SA105	1101001	348000–34FFFF
SA63	0111111	2F8000–2FFFFF	SA106	1101010	350000–357FFF
SA64	1000000	100000–107FFF	SA107	1101011	358000–35FFFF
SA65	1000001	108000–10FFFF	SA108	1101100	360000–367FFF

**Table I4. S29GL064A (Models R6, R7) Sector Addresses (Sheet 2 of 2)**

Sector	A21–A15	16-bit Address Range	Sector	A21–A15	16-bit Address Range
SA66	1000010	110000–117FFF	SA109	1101101	368000–36FFFF
SA67	1000011	118000–11FFFF	SA110	1101110	370000–377FFF
SA68	1000100	120000–127FFF	SA111	1101111	378000–37FFFF
SA69	1000101	128000–12FFFF	SA112	1110000	380000–387FFF
SA70	1000110	130000–137FFF	SA113	1110001	388000–38FFFF
SA71	1000111	138000–13FFFF	SA114	1110010	390000–397FFF
SA72	1001000	140000–147FFF	SA115	1110011	398000–39FFFF
SA73	1001001	148000–14FFFF	SA116	1110100	3A0000–3A7FFF
SA74	1001010	150000–157FFF	SA117	1110101	3A8000–3AFFFF
SA75	1001011	158000–15FFFF	SA118	1110110	3B0000–3B7FFF
SA76	1001100	160000–167FFF	SA119	1110111	3B8000–3BFFFF
SA77	1001101	168000–16FFFF	SA120	1111000	3C0000–3C7FFF
SA78	1001110	170000–177FFF	SA121	1111001	3C8000–3CFFFF
SA79	1001111	178000–17FFFF	SA122	1111010	3D0000–3D7FFF
SA80	1010000	180000–187FFF	SA123	1111011	3D8000–3DFFFF
SA81	1010001	188000–18FFFF	SA124	1111100	3E0000–3E7FFF
SA82	1010010	190000–197FFF	SA125	1111101	3E8000–3EFFFF
SA83	1010011	198000–19FFFF	SA126	1111110	3F0000–3F7FFF
SA84	1010100	1A0000–1A7FFF	SA127	1111111	3F8000–3FFFFF

## Autoselect Mode

The autoselect mode provides manufacturer and device identification, and sector group protection verification, through identifier codes output on DQ7–DQ0. This mode is primarily intended for programming equipment to automatically match a device to be programmed with its corresponding programming algorithm. However, the autoselect codes can also be accessed in-system through the command register.

When using programming equipment, the autoselect mode requires  $V_{ID}$  on address pin A9. Address pins A6, A3, A2, A1, and A0 must be as shown in [Table 15 on page 38](#). In addition, when verifying sector protection, the sector address must appear on the appropriate highest order address bits (see [Table 7-Table 25](#)). [Table 15 on page 38](#) shows the remaining address bits that are don't care. When all necessary bits are set as required, the programming equipment may then read the corresponding identifier code on DQ7–DQ0.

To access the autoselect codes in-system, the host system can issue the autoselect command via the command register, as shown in [Table 30 on page 61](#) and [Table 31 on page 62](#). This method does not require  $V_{ID}$ . Refer to the Autoselect Command Sequence section for more information.

**Table I5. Autoselect Codes, (High Voltage Method)**

Description	CE#	OE#	WE#	A22 to A15	A14 to A10	A9	A8 to A7	A6	A5 to A4	A3 to A2	A1	A0	DQ8 to DQ15		DQ7 to DQ0		
													BYTE# = V <sub>IH</sub>	BYTE# = V <sub>IL</sub>	Model Number		
															R1, R2, W1, W2, R8, R9	R3, R4, W3, W4	R5, R6, R7
Manufacturer ID: Spansion Products	L	L	H	X	X	V <sub>ID</sub>	X	L	X	L	L	L	00	X	01h	01h	01h
S29GL064A	L	L	H	X	X	V <sub>ID</sub>	X	L	X	L	L	H	22	X	7Eh	7Eh	7Eh
										H	H	L	22	X	0Ch	10h	13h
										H	H	H	22	X	01h	00h (-R4, bottom boot) 01h (-R3, top boot)	01h
S29GL032A	L	L	H	X	X	V <sub>ID</sub>	X	L	X	L	L	H	22	X	7Eh	7Eh	
										H	H	L	22	X	1Dh	1Ah	
										H	H	H	22	X	00h	00h (-R4, bottom boot) 01h (-R3, top boot)	
S29GL016A	L	L	H	X	X	V <sub>ID</sub>	X	X	X	X	L	H	22	X	49h (-R2, -02, -W2, bottom boot) C4h (-R1, -01, -W1, top boot)		
Sector Group Protection Verification	L	L	H	SA	X	V <sub>ID</sub>	X	L	X	L	H	L	X	X	01h (protected), 00h (unprotected)		
Secured Silicon Sector Indicator Bit (DQ7), WP# protects highest address sector	L	L	H	X	X	V <sub>ID</sub>	X	L	X	L	H	H	X	X	For S29GL064A and S29GL032A: 99h (factory locked), 19h (not factory locked) For S29GL016A: 94h (factory locked), 14h (not factory locked)		
Secured Silicon Sector Indicator Bit (DQ7), WP# protects lowest address sector	L	L	H	X	X	V <sub>ID</sub>	X	L	X	L	H	H	X	X	For S29GL064A and S29GL032A: 89h (factory locked), 09h (not factory locked) For S29GL016A: 84h (factory locked), 04h (not factory locked)		

**Legend:** L = Logic Low = V<sub>IL</sub>, H = Logic High = V<sub>IH</sub>, SA = Sector Address, X = Don't care.

### Sector Group Protection and Unprotection

The hardware sector group protection feature disables both program and erase operations in any sector group (see [Tables 14 – 25](#)). The hardware sector group unprotection feature re-enables both program and erase operations in previously protected sector groups. Sector group protection/unprotection can be implemented via two methods.

Sector protection/unprotection requires V<sub>ID</sub> on the RESET# pin only, and can be implemented either in-system or via programming equipment. [Figure 2, on page 44](#) shows the algorithms and [Figure 24, on page 86](#) shows the timing diagram. This method uses standard microprocessor bus cycle timing. For sector group unprotect, all unprotected sector groups must first be protected prior to the first sector group unprotect write cycle.

The device is shipped with all sector groups unprotected. Spansion offers the option of programming and protecting sector groups at its factory prior to shipping the device through Spansion Programming Service. Contact a Spansion representative for details.

It is possible to determine whether a sector group is protected or unprotected. See [Autoselect Mode on page 37](#) for details.



**Table 16. S29GL016A (Model RI, 0I, WI) Sector Group Protection/Unprotection Addresses**

Sector	A19–A12	Sector/Sector Block Size (Kbytes)	Sector	A19–A12	Sector/Sector Block Size (Kbytes)
SA0-SA3	000XXXXh	256 (4x64)	SA31	11111000h	8
SA4-SA7	001XXXXh	256 (4x64)	SA32	11111001h	8
SA8-SA11	010XXXXh	256 (4x64)	SA33	11111010h	8
SA12-SA15	011XXXXh	256 (4x64)	SA34	11111011h	8
SA16-SA19	100XXXXh	256 (4x64)	SA35	11111100h	8
SA20-SA23	101XXXXh	256 (4x64)	SA36	11111101h	8
SA24-SA27	110XXXXh	256 (4x64)	SA37	11111110h	8
SA28-SA30	11100XXXh	192 (3x64)	SA38	11111111h	8
	11101XXXh				
	11110XXXh				

**Table 17. S29GL016A (Model R2, 02, W2) Sector Group Protection/Unprotection Addresses**

Sector	A19–A12	Sector/Sector Block Size (Kbytes)	Sector	A19–A12	Sector/Sector Block Size (Kbytes)
SA0	00000000h	8	SA8–SA10	00001XXXh	192 (3x64)
SA1	00000001h	8		00010XXXh	
SA2	00000010h	8		00011XXXh	
SA3	00000011h	8	SA11–SA14	001XXXXh	256 (4x64)
SA4	00000100h	8	SA15–SA18	010XXXXh	256 (4x64)
SA5	00000101h	8	SA19–SA22	011XXXXh	256 (4x64)
SA6	00000110h	8	SA23–SA26	100XXXXh	256 (4x64)
SA7	00000111h	8	SA27-SA30	101XXXXh	256 (4x64)
			SA31-SA34	110XXXXh	256 (4x64)
			SA35-SA38	111XXXXh	256 (4x64)

**Table 18. S29GL032A (Models RI, R2, WI, W2) Sector Group Protection/Unprotection Addresses**

Sector	A20–A15	Sector /Sector Block Size (Kbytes)	Sector	A20–A15	Sector /Sector Block Size (Kbytes)	Sector	A20–A15	Sector /Sector Block Size (Kbytes)	Sector	A20–A15	Sector /Sector Block Size (Kbytes)
SA0	000000	64	SA12–SA15	0011xx	256 (4x64)	SA36–SA39	1001xx	256 (4x64)	SA56–SA59	1110xx	256 (4x64)
SA1	000001	64	SA16–SA19	0100xx	256 (4x64)	SA40–SA43	1010xx	256 (4x64)	SA60	111100	64
SA2	000010	64	SA20–SA23	0101xx	256 (4x64)	SA44–SA47	1011xx	256 (4x64)	SA61	111101	64
SA3	000011	64	SA24–SA27	0110xx	256 (4x64)	SA48–SA51	1100xx	256 (4x64)	SA62	111110	64
SA4–SA7	0001xx	256 (4x64)	SA28–SA31	0111xx	256 (4x64)	SA52–SA55	1101xx	256 (4x64)	SA63	111111	64
SA8–SA11	0010xx	256 (4x64)	SA32–SA35	1000xx	256 (4x64)						

**Table 19. S29GL032A (Model R3, W3) Sector Group Protection/Unprotection Address Table**

Sector	A20–A12	Sector/Sector Block Size (Kbytes)	Sector	A20–A12	Sector/Sector Block Size (Kbytes)	Sector	A20–A12	Sector/Sector Block Size (Kbytes)
SA0-SA3	0000XXXXXh	256 (4x64)	SA36-SA39	1001XXXXXh	256 (4x64)	SA63	111111000h	8
SA4-SA7	0001XXXXXh	256 (4x64)	SA40-SA43	1010XXXXXh	256 (4x64)	SA64	111111001h	8
SA8-SA11	0010XXXXXh	256 (4x64)	SA44-SA47	1011XXXXXh	256 (4x64)	SA65	111111010h	8
SA12-SA15	0011XXXXXh	256 (4x64)	SA48-SA51	1100XXXXXh	256 (4x64)	SA66	111111011h	8
SA16-SA19	0100XXXXXh	256 (4x64)	SA52-SA55	1101XXXXXh	256 (4x64)	SA67	111111100h	8
SA20-SA23	0101XXXXXh	256 (4x64)	SA56-SA59	1110XXXXXh	256 (4x64)	SA68	111111101h	8
SA24-SA27	0110XXXXXh	256 (4x64)	SA60-SA62	111100XXXh	192 (3x64)	SA69	111111110h	8
SA28-SA31	0111XXXXXh	256 (4x64)		111101XXXh		SA70	111111111h	8
SA32-SA35	1000XXXXXh	256 (4x64)		111110XXXh				

**Table 20. S29GL032A (Model R4, W4) Sector Group Protection/Unprotection Address Table**

Sector	A20–A12	Sector/Sector Block Size (Kbytes)	Sector	A20–A12	Sector/Sector Block Size (Kbytes)	Sector	A20–A12	Sector/Sector Block Size (Kbytes)
SA0	000000000h	8	SA8-SA10	000001XXXh	192 (3x64)	SA35-SA38	0111XXXXXh	256 (4x64)
SA1	000000001h	8		000010XXXh		SA39-SA42	1000XXXXXh	256 (4x64)
SA2	000000010h	8		000011XXXh		SA43-SA46	1001XXXXXh	256 (4x64)
SA3	000000011h	8	SA11-SA14	0001XXXXXh	256 (4x64)	SA47-SA50	1010XXXXXh	256 (4x64)
SA4	000000100h	8	SA15-SA18	0010XXXXXh	256 (4x64)	SA51-SA54	1011XXXXXh	256 (4x64)
SA5	000000101h	8	SA19-SA22	0011XXXXXh	256 (4x64)	SA55-SA58	1100XXXXXh	256 (4x64)
SA6	000000110h	8	SA23-SA26	0100XXXXXh	256 (4x64)	SA59-SA62	1101XXXXXh	256 (4x64)
SA7	000000111h	8	SA27-SA30	0101XXXXXh	256 (4x64)	SA63-SA66	1110XXXXXh	256 (4x64)
			SA31-SA34	0110XXXXXh	256 (4x64)	SA67-SA70	1111XXXXXh	256 (4x64)

**Table 21. S29GL064A (Models RI, R2, R8, R9, WI, W2) Sector Group Protection/Unprotection Addresses**

Sector	A21–A15	Sector/Sector Block Size (Kbytes)	Sector	A21–A15	Sector/Sector Block Size (Kbytes)	Sector	A21–A15	Sector/Sector Block Size (Kbytes)	Sector	A21–A15	Sector/Sector Block Size (Kbytes)
SA0	0000000	64	SA28-SA31	00111xx	256 (4x64)	SA68-SA71	10001xx	256 (4x64)	SA108-SA111	11011xx	256 (4x64)
SA1	0000001	64	SA32-SA35	01000xx	256 (4x64)	SA72-SA75	10010xx	256 (4x64)	SA112-SA115	11100xx	256 (4x64)
SA2	0000010	64	SA36-SA39	01001xx	256 (4x64)	SA76-SA79	10011xx	256 (4x64)	SA116-SA119	11101xx	256 (4x64)
SA3	0000011	64	SA40-SA43	01010xx	256 (4x64)	SA80-SA83	10100xx	256 (4x64)	SA120-SA123	11110xx	256 (4x64)
SA4-SA7	00001xx	256 (4x64)	SA44-SA47	01011xx	256 (4x64)	SA84-SA87	10101xx	256 (4x64)	SA124	1111100	64
SA8-SA11	00010xx	256 (4x64)	SA48-SA51	01100xx	256 (4x64)	SA88-SA91	10110xx	256 (4x64)	SA125	1111101	64
SA12-SA15	00011xx	256 (4x64)	SA52-SA55	01101xx	256 (4x64)	SA92-SA95	10111xx	256 (4x64)	SA126	1111110	64
SA16-SA19	00100xx	256 (4x64)	SA56-SA59	01110xx	256 (4x64)	SA96-SA99	11000xx	256 (4x64)	SA127	1111111	64
SA20-SA23	00101xx	256 (4x64)	SA60-SA63	01111xx	256 (4x64)	SA100-SA103	11001xx	256 (4x64)			
SA24-SA27	00110xx	256 (4x64)	SA64-SA67	10000xx	256 (4x64)	SA104-SA107	11010xx	256 (4x64)			

**Table 22. S29GL064A (Model R3, W3) Top Boot Sector Protection/Unprotection Addresses**

Sector	A21–A12	Sector/Sector Block Size (Kbytes)	Sector	A20–A12	Sector/Sector Block Size (Kbytes)	Sector	A20–A12	Sector/Sector Block Size (Kbytes)
SA0-SA3	00000XXXXX	256 (4x64)	SA56-SA59	01110XXXXX	256 (4x64)	SA112-SA115	11100XXXXX	256 (4x64)
SA4-SA7	00001XXXXX	256 (4x64)	SA60-SA63	01111XXXXX	256 (4x64)	SA116-SA119	11101XXXXX	256 (4x64)
SA8-SA11	00010XXXXX	256 (4x64)	SA64-SA67	10000XXXXX	256 (4x64)	SA120-SA123	11110XXXXX	256 (4x64)
SA12-SA15	00011XXXXX	256 (4x64)	SA68-SA71	10001XXXXX	256 (4x64)	SA124-SA126	1111100XXX 1111101XXX 1111110XXX	192 (3x64)
SA16-SA19	00100XXXXX	256 (4x64)	SA72-SA75	10010XXXXX	256 (4x64)	SA127	1111111000	8
SA20-SA23	00101XXXXX	256 (4x64)	SA76-SA79	10011XXXXX	256 (4x64)	SA128	1111111001	8
SA24-SA27	00110XXXXX	256 (4x64)	SA80-SA83	10100XXXXX	256 (4x64)	SA129	1111111010	8
SA28-SA31	00111XXXXX	256 (4x64)	SA84-SA87	10101XXXXX	256 (4x64)	SA130	1111111011	8
SA32-SA35	01000XXXXX	256 (4x64)	SA88-SA91	10110XXXXX	256 (4x64)	SA131	1111111100	8
SA36-SA39	01001XXXXX	256 (4x64)	SA92-SA95	10111XXXXX	256 (4x64)	SA132	1111111101	8
SA40-SA43	01010XXXXX	256 (4x64)	SA96-SA99	11000XXXXX	256 (4x64)	SA133	1111111110	8
SA44-SA47	01011XXXXX	256 (4x64)	SA100-SA103	11001XXXXX	256 (4x64)	SA134	1111111111	8
SA48-SA51	01100XXXXX	256 (4x64)	SA104-SA107	11010XXXXX	256 (4x64)			
SA52-SA55	01101XXXXX	256 (4x64)	SA108-SA111	11011XXXXX	256 (4x64)			

**Table 23. S29GL064A (Model R4, W4) Bottom Boot Sector Protection/Unprotection Addresses**

Sector	A21–A12	Sector/Sector Block Size (Kbytes)	Sector	A20–A12	Sector/Sector Block Size (Kbytes)	Sector	A20–A12	Sector/Sector Block Size (Kbytes)
SA0	0000000000	8	SA31-SA34	00110XXXXX	256 (4x64)	SA87-SA90	10100XXXXX	256 (4x64)
SA1	0000000001	8	SA35-SA38	00111XXXXX	256 (4x64)	SA91-SA94	10101XXXXX	256 (4x64)
SA2	0000000010	8	SA39-SA42	01000XXXXX	256 (4x64)	SA95-SA98	10110XXXXX	256 (4x64)
SA3	0000000011	8	SA43-SA46	01001XXXXX	256 (4x64)	SA99-SA102	10111XXXXX	256 (4x64)
SA4	0000000100	8	SA47-SA50	01010XXXXX	256 (4x64)	SA103-SA106	11000XXXXX	256 (4x64)
SA5	0000000101	8	SA51-SA54	01011XXXXX	256 (4x64)	SA107-SA110	11001XXXXX	256 (4x64)
SA6	0000000110	8	SA55-SA58	01100XXXXX	256 (4x64)	SA111-SA114	11010XXXXX	256 (4x64)
SA7	0000000111	8	SA59-SA62	01101XXXXX	256 (4x64)	SA115-SA118	11011XXXXX	256 (4x64)
SA8-SA10	0000001XXX, 0000010XXX, 0000011XXX,	192 (3x64)	SA63-SA66	01110XXXXX	256 (4x64)	SA119-SA122	11100XXXXX	256 (4x64)
SA11-SA14	00001XXXXX	256 (4x64)	SA67-SA70	01111XXXXX	256 (4x64)	SA123-SA126	11101XXXXX	256 (4x64)
SA15-SA18	00010XXXXX	256 (4x64)	SA71-SA74	10000XXXXX	256 (4x64)	SA127-SA130	11110XXXXX	256 (4x64)
SA19-SA22	00011XXXXX	256 (4x64)	SA75-SA78	10001XXXXX	256 (4x64)	SA131-SA134	11111XXXXX	256 (4x64)
SA23-SA26	00100XXXXX	256 (4x64)	SA79-SA82	10010XXXXX	256 (4x64)			
SA27-SA30	00101XXXXX	256 (4x64)	SA83-SA86	10011XXXXX	256 (4x64)			

**Table 24. S29GL064A (Model R5) Sector Group Protection/Unprotection Addresses**

Sector	A21–A15	Sector/ Sector Block Size (Kbytes)	Sector	A21–A15	Sector/ Sector Block Size (Kbytes)	Sector	A21–A15	Sector/ Sector Block Size (Kbytes)	Sector	A21–A15	Sector/ Sector Block Size (Kbytes)
SA0–SA3	00000	256 (4x64)	SA32–SA35	01000	256 (4x64)	SA64–SA67	10000	256 (4x64)	SA96–SA99	11000	256 (4x64)
SA4–SA7	00001	256 (4x64)	SA36–SA39	01001	256 (4x64)	SA68–SA71	10001	256 (4x64)	SA100–SA103	11001	256 (4x64)
SA8–SA11	00010	256 (4x64)	SA40–SA43	01010	256 (4x64)	SA72–SA75	10010	256 (4x64)	SA104–SA107	11010	256 (4x64)
SA12–SA15	00011	256 (4x64)	SA44–SA47	01011	256 (4x64)	SA76–SA79	10011	256 (4x64)	SA108–SA111	11011	256 (4x64)
SA16–SA19	00100	256 (4x64)	SA48–SA51	01100	256 (4x64)	SA80–SA83	10100	256 (4x64)	SA112–SA115	11100	256 (4x64)
SA20–SA23	00101	256 (4x64)	SA52–SA55	01101	256 (4x64)	SA84–SA87	10101	256 (4x64)	SA116–SA119	11101	256 (4x64)
SA24–SA27	00110	256 (4x64)	SA56–SA59	01110	256 (4x64)	SA88–SA91	10110	256 (4x64)	SA120–SA123	11110	256 (4x64)
SA28–SA31	00111	256 (4x64)	SA60–SA63	01111	256 (4x64)	SA92–SA95	10111	256 (4x64)	SA124–SA127	11111	256 (4x64)

**Table 25. S29GL064A (Models R6, R7) Sector Group Protection/Unprotection Addresses**

Sector	A21–A15	Sector/ Sector Block Size (Kbytes)	Sector	A21–A15	Sector/ Sector Block Size (Kbytes)	Sector	A21–A15	Sector/ Sector Block Size (Kbytes)	Sector	A21–A15	Sector/ Sector Block Size (Kbytes)
SA0–SA3	00000	256 (4x64)	SA32–SA35	01000	256 (4x64)	SA64–SA67	10000	256 (4x64)	SA96–SA99	11000	256 (4x64)
SA4–SA7	00001	256 (4x64)	SA36–SA39	01001	256 (4x64)	SA68–SA71	10001	256 (4x64)	SA100–SA103	11001	256 (4x64)
SA8–SA11	00010	256 (4x64)	SA40–SA43	01010	256 (4x64)	SA72–SA75	10010	256 (4x64)	SA104–SA107	11010	256 (4x64)
SA12–SA15	00011	256 (4x64)	SA44–SA47	01011	256 (4x64)	SA76–SA79	10011	256 (4x64)	SA108–SA111	11011	256 (4x64)
SA16–SA19	00100	256 (4x64)	SA48–SA51	01100	256 (4x64)	SA80–SA83	10100	256 (4x64)	SA112–SA115	11100	256 (4x64)
SA20–SA23	00101	256 (4x64)	SA52–SA55	01101	256 (4x64)	SA84–SA87	10101	256 (4x64)	SA116–SA119	11101	256 (4x64)
SA24–SA27	00110	256 (4x64)	SA56–SA59	01110	256 (4x64)	SA88–SA91	10110	256 (4x64)	SA120–SA123	11110	256 (4x64)
SA28–SA31	00111	256 (4x64)	SA60–SA63	01111	256 (4x64)	SA92–SA95	10111	256 (4x64)	SA124–SA127	11111	256 (4x64)

## Temporary Sector Group Unprotect

This feature allows temporary unprotection of previously protected sector groups to change data in-system. The Sector Group Unprotect mode is activated by setting the RESET# pin to  $V_{ID}$ . During this mode, formerly protected sector groups can be programmed or erased by selecting the sector group addresses. Once  $V_{ID}$  is removed from the RESET# pin, all the previously protected sector groups are protected again. [Figure 1](#) shows the algorithm, and [Figure 22, on page 82](#) shows the timing diagrams, for this feature.

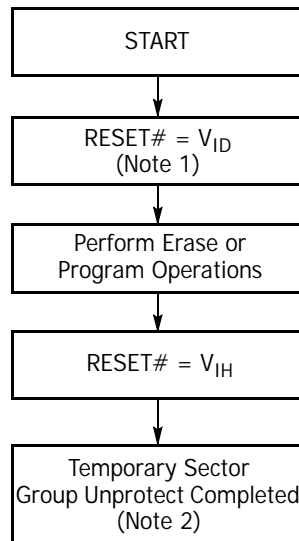

**Notes:**

1. All protected sector groups unprotected (If WP# =  $V_{IL}$ , the highest or lowest address sector remains protected for uniform sector devices; the top or bottom two address sectors remains protected for boot sector devices).
2. All previously protected sector groups are protected once again.

**Figure 1. Temporary Sector Group Unprotect Operation**

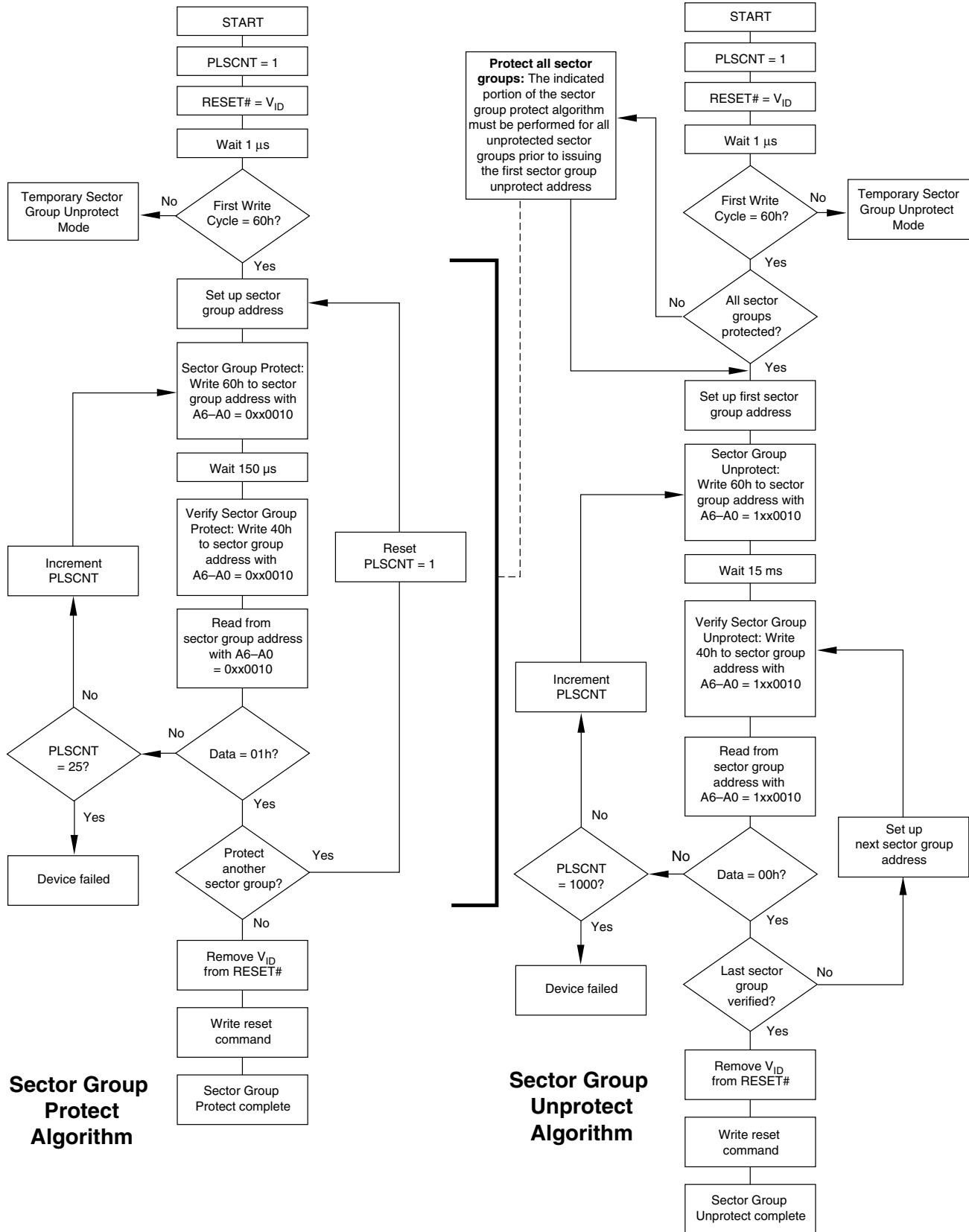

Figure 2. In-System Sector Group Protect/Unprotect Algorithms

## Secured Silicon Sector Flash Memory Region

The Secured Silicon Sector feature provides a Flash memory region that enables permanent part identification through an Electronic Serial Number (ESN). The Secured Silicon Sector is 256 bytes in length, and uses a Secured Silicon Sector Indicator Bit (DQ7) to indicate whether or not the Secured Silicon Sector is locked when shipped from the factory. This bit is permanently set at the factory and cannot be changed, which prevents cloning of a factory locked part. This ensures the security of the ESN once the product is shipped to the field.

The factory offers the device with the Secured Silicon Sector either customer lockable (standard shipping option) or factory locked (contact a Spansion sales representative for ordering information). The customer-lockable version is shipped with the Secured Silicon Sector unprotected, allowing customers to program the sector after receiving the device. The customer-lockable version also contains the Secured Silicon Sector Indicator Bit permanently set to a 0. The factory-locked version is always protected when shipped from the factory, and has the Secured Silicon Sector Indicator Bit permanently set to a 1. Thus, the Secured Silicon Sector Indicator Bit prevents customer-lockable devices from being used to replace devices that are factory locked. *Note that the ACC function and unlock bypass modes are not available when the Secured Silicon Sector is enabled.*

The Secured Silicon sector address space in this device is allocated as follows:

Secured Silicon Sector Address Range		Standard Factory Locked	ExpressFlash Factory Locked	Customer Lockable
x16	x8			
000000h–000007h	000000h–00000Fh	ESN	ESN or determined by customer	Determined by customer
000008h–00007Fh	000010h–0000FFh	Unavailable	Determined by customer	

The system accesses the Secured Silicon Sector through a command sequence (see [Write Protect \(WP#\) on page 46](#)). After the system writes the Enter Secured Silicon Sector command sequence, it may read the Secured Silicon Sector by using the addresses normally occupied by the first sector (SA0). This mode of operation continues until the system issues the Exit Secured Silicon Sector command sequence, or until power is removed from the device. On power-up, or following a hardware reset, the device reverts to sending commands to sector SA0.

### Customer Lockable: Secured Silicon Sector NOT Programmed or Protected At the Factory

Unless otherwise specified, the device is shipped such that the customer may program and protect the 256-byte Secured Silicon sector.

The system may program the Secured Silicon Sector using the write-buffer, accelerated and/or unlock bypass methods, in addition to the standard programming command sequence. See [Command Definitions on page 50](#).

Programming and protecting the Secured Silicon Sector must be used with caution since, once protected, there is no procedure available for unprotecting the Secured Silicon Sector area and none of the bits in the Secured Silicon Sector memory space can be modified in any way.

The Secured Silicon Sector area can be protected using one of the following procedures:

- Write the three-cycle Enter Secured Silicon Sector Region command sequence, and then follow the in-system sector protect algorithm as shown in [Figure 2, on page 44](#), except that *RESET#* may be at either  $V_{IH}$  or  $V_{ID}$ . This allows in-system protection of the Secured Silicon Sector without raising any device pin to a high voltage. Note that this method is only applicable to the Secured Silicon Sector.
- Write the three-cycle Enter Secured Silicon Sector Region command sequence, and then use the alternate method of sector protection described in the [Sector Group Protection and Unprotection on page 38](#) section.

Once the Secured Silicon Sector is programmed, locked and verified, the system must write the Exit Secured Silicon Sector Region command sequence to return to reading and writing within the remainder of the array.

### Factory Locked: Secured Silicon Sector Programmed and Protected At the Factory

In devices with an ESN, the Secured Silicon Sector is protected when the device is shipped from the factory. The Secured Silicon Sector cannot be modified in any way. An ESN Factory Locked device has an 16-byte random ESN at addresses 000000h–000007h. Please contact your sales representative for details on ordering ESN Factory Locked devices.

Customers may opt to have their code programmed by the factory through the Spansion programming service (Customer Factory Locked). The devices are then shipped from the factory with the Secured Silicon Sector permanently locked. Contact your sales representative for details on using the Spansion programming service.

### Write Protect (WP#)

The Write Protect function provides a hardware method of protecting the first or last sector group without using  $V_{ID}$ . Write Protect is one of two functions provided by the WP#/ACC input.

If the system asserts  $V_{IL}$  on the WP#/ACC pin, the device disables program and erase functions in the first or last sector group independently of whether those sector groups were protected or unprotected. Note that if WP#/ACC is at  $V_{IL}$  when the device is in the standby mode, the maximum input load current is increased. See the table in [DC Characteristics on page 71](#).

**If the system asserts  $V_{IH}$  on the WP#/ACC pin, the device reverts to whether the first or last sector was previously set to be protected or unprotected using the method described in [Sector Group Protection and Unprotection on page 38](#). Note that WP# contains an internal pullup; when unconnected, WP# is at  $V_{IH}$ .**

### Hardware Data Protection

The command sequence requirement of unlock cycles for programming or erasing provides data protection against inadvertent writes (refer to [Table 30 on page 61](#) and [Table 31 on page 62](#) for command definitions). In addition, the following hardware data protection measures prevent accidental erasure or programming, which might otherwise be caused by spurious system level signals during  $V_{CC}$  power-up and power-down transitions, or from system noise.



### Low $V_{CC}$ Write Inhibit

When  $V_{CC}$  is less than  $V_{LKO}$ , the device does not accept any write cycles. This protects data during  $V_{CC}$  power-up and power-down. The command register and all internal program/erase circuits are disabled, and the device resets to the read mode. Subsequent writes are ignored until  $V_{CC}$  is greater than  $V_{LKO}$ . The system must provide the proper signals to the control pins to prevent unintentional writes when  $V_{CC}$  is greater than  $V_{LKO}$ .

### Write Pulse *Glitch* Protection

Noise pulses of less than 3 ns (typical) on OE#, CE# or WE# do not initiate a write cycle.

### Logical Inhibit

Write cycles are inhibited by holding any one of OE# =  $V_{IL}$ , CE# =  $V_{IH}$  or WE# =  $V_{IH}$ . To initiate a write cycle, CE# and WE# must be a logical zero while OE# is a logical one.

### Power-Up Write Inhibit

If WE# = CE# =  $V_{IL}$  and OE# =  $V_{IH}$  during power up, the device does not accept commands on the rising edge of WE#. The internal state machine is automatically reset to the read mode on power-up.

## Common Flash Memory Interface (CFI)

The Common Flash Interface (CFI) specification outlines device and host system software interrogation handshake, which allows specific vendor-specified software algorithms to be used for entire families of devices. Software support can then be device-independent, JEDEC ID-independent, and forward- and backward-compatible for the specified flash device families. Flash vendors can standardize their existing interfaces for long-term compatibility.

This device enters the CFI Query mode when the system writes the CFI Query command, 98h, to address 55h, any time the device is ready to read array data. The system can read CFI information at the addresses given in [Tables 26–29](#). To terminate reading CFI data, the system must write the reset command.

The system can also write the CFI query command when the device is in the autoselect mode. The device enters the CFI query mode, and the system can read CFI data at the addresses given in [Tables 26–29](#). The system must write the reset command to return the device to reading array data.

For further information, please refer to the CFI Specification and CFI Publication 100. Alternatively, contact your sales representative for copies of these documents.

**Table 26. CFI Query Identification String**

Addresses (x16)	Addresses (x8)	Data	Description
10h 11h 12h	20h 22h 24h	0051h 0052h 0059h	Query Unique ASCII string "QRY"
13h 14h	26h 28h	0002h 0000h	Primary OEM Command Set
15h 16h	2Ah 2Ch	0040h 0000h	Address for Primary Extended Table
17h 18h	2Eh 30h	0000h 0000h	Alternate OEM Command Set (00h = none exists)
19h 1Ah	32h 34h	0000h 0000h	Address for Alternate OEM Extended Table (00h = none exists)

**Table 27. System Interface String**

Addresses (x16)	Addresses (x8)	Data	Description
1Bh	36h	0027h	V <sub>CC</sub> Min. (write/erase) D7-D4: volt, D3-D0: 100 millivolt
1Ch	38h	0036h	V <sub>CC</sub> Max. (write/erase) D7-D4: volt, D3-D0: 100 millivolt
1Dh	3Ah	0000h	V <sub>PP</sub> Min. voltage (00h = no V <sub>PP</sub> pin present)
1Eh	3Ch	0000h	V <sub>PP</sub> Max. voltage (00h = no V <sub>PP</sub> pin present)
1Fh	3Eh	0007h	Reserved for future use
20h	40h	0007h	Typical timeout for Min. size buffer write 2 <sup>n</sup> μs (00h = not supported)
21h	42h	000Ah	Typical timeout per individual block erase 2 <sup>n</sup> ms
22h	44h	0000h	Typical timeout for full chip erase 2 <sup>n</sup> ms (00h = not supported)
23h	46h	0001h	Reserved for future use
24h	48h	0005h	Max. timeout for buffer write 2 <sup>n</sup> times typical
25h	4Ah	0004h	Max. timeout per individual block erase 2 <sup>n</sup> times typical
26h	4Ch	0000h	Max. timeout for full chip erase 2 <sup>n</sup> times typical (00h = not supported)

**Note:** CFI data related to V<sub>CC</sub> and time-outs may differ from actual V<sub>CC</sub> and time-outs of the product. Please consult the Ordering Information tables to obtain the V<sub>CC</sub> range for particular part numbers. Please consult the Erase and Programming Performance table for typical timeout specifications.

**Table 28. Device Geometry Definition (Sheet I of 2)**

Addresses (x16)	Addresses (x8)	Data	Description
27h	4Eh	00xxh	Device Size = 2 <sup>n</sup> byte 0017h = 64 Mb, 0016h = 32Mb, 0015h = 16Mb
28h 29h	50h 52h	000xh 0000h	Flash Device Interface description (refer to CFI publication 100) 0000h = x8-only bus devices 0001h = x16-only bus devices 0002h = x8/x16 bus devices
2Ah 2Bh	54h 56h	0005h 0000h	Max. number of byte in multi-byte write = 2 <sup>n</sup> (00h = not supported)
2Ch	58h	00xxh	Number of Erase Block Regions within device (01h = uniform device, 02h = boot device)
2Dh 2Eh 2Fh 30h	5Ah 5Ch 5Eh 60h	00xxh 000xh 00x0h 000xh	Erase Block Region 1 Information (refer to the CFI specification or CFI publication 100) 0000h, 0020h, 0000h, 0007h = 16 Mb (-R1, -R2) 007Fh, 0000h, 0020h, 0000h = 32 Mb (-R1, -R2) 003Fh, 0000h, 0001h = 32 Mb (-R3, R4) 007Fh, 0000h, 0020h, 0000h = 64 Mb (-R1, -R2, -R8, -R9) 007Fh, 0000h, 0000h, 0001h = 64 Mb (-R3, -R4, -R5, -R6, -R7)

**Table 28. Device Geometry Definition (Sheet 2 of 2)**

Addresses (x16)	Addresses (x8)	Data	Description
31h 32h 33h 34h	60h 64h 66h 68h	00xxh 0000h 0000h 000xh	Erase Block Region 2 Information (refer to CFI publication 100) 0001h, 0000h, 0000h, 001Eh = 16 Mb (-R1, -R2) 003Eh, 0000h, 0000h, 0001h = 32 Mb (-R1, -R2) 007Eh, 0000h, 0000h, 0001h = 64 Mb (-R1, -R2, -R8, -R9) 0000h, 0000h, 0000h, 0000h = all others
35h 36h 37h 38h	6Ah 6Ch 6Eh 70h	0000h 0000h 0000h 0000h	Erase Block Region 3 Information (refer to CFI publication 100)
39h 3Ah 3Bh 3Ch	72h 74h 76h 78h	0000h 0000h 0000h 0000h	Erase Block Region 4 Information (refer to CFI publication 100)

**Table 29. Primary Vendor-Specific Extended Query**

Addresses (x16)	Addresses (x8)	Data	Description
40h 41h 42h	80h 82h 84h	0050h 0052h 0049h	Query-unique ASCII string "PRI"
43h	86h	0031h	Major version number, ASCII
44h	88h	0033h	Minor version number, ASCII
45h	8Ah	000xh	Address Sensitive Unlock (Bits 1-0) 0 = Required, 1 = Not Required Process Technology (Bits 7-2) 0010b = 200 nm MirrorBit 0009h = x8-only bus devices 0008h = all other devices
46h	8Ch	0002h	Erase Suspend 0 = Not Supported, 1 = To Read Only, 2 = To Read & Write
47h	8Eh	0001h	Sector Protect 0 = Not Supported, X = Number of sectors in smallest sector group
48h	90h	0001h	Sector Temporary Unprotect 00 = Not Supported, 01 = Supported
49h	92h	0004h	Sector Protect/Unprotect scheme 0004h = Standard Mode (Refer to Text)
4Ah	94h	0000h	Simultaneous Operation 00 = Not Supported, X = Number of Sectors in Bank
4Bh	96h	0000h	Burst Mode Type 00 = Not Supported, 01 = Supported
4Ch	98h	0001h	Page Mode Type 00 = Not Supported, 01 = 4 Word Page, 02 = 8 Word Page
4Dh	9Ah	00B5h	ACC (Acceleration) Supply Minimum 00h = Not Supported, D7-D4: Volt, D3-D0: 100 mV
4Eh	9Ch	00C5h	ACC (Acceleration) Supply Maximum 00h = Not Supported, D7-D4: Volt, D3-D0: 100 mV
4Fh	9Eh	00xxh	Top/Bottom Boot Sector Flag 02h = Bottom Boot Device, 03h = Top Boot Device, 04h = Uniform sectors bottom WP# protect, 05h = Uniform sectors top WP# protect
50h	A0h	0001h	Program Suspend 00h = Not Supported, 01h = Supported

## Command Definitions

Writing specific address and data commands or sequences into the command register initiates device operations. [Table 30 on page 61](#) and [Table 31 on page 62](#) define the valid register command sequences. *Writing incorrect address and data values or writing them in the improper sequence may place the device in an unknown state.* A reset command is then required to return the device to reading array data.

All addresses are latched on the falling edge of WE# or CE#, whichever happens later. All data is latched on the rising edge of WE# or CE#, whichever happens first. Refer to the AC Characteristics section for timing diagrams.

### Reading Array Data

The device is automatically set to reading array data after device power-up. No commands are required to retrieve data. The device is ready to read array data after completing an Embedded Program or Embedded Erase algorithm.

After the device accepts an Erase Suspend command, the device enters the erase-suspend-read mode, after which the system can read data from any non-erase-suspended sector. After completing a programming operation in the Erase Suspend mode, the system may once again read array data with the same exception. See [Erase Suspend/Erase Resume Commands on page 59](#) for more information.

The system *must* issue the reset command to return the device to the read (or erase-suspend-read) mode if DQ5 goes high during an active program or erase operation, or if the device is in the autoselect mode. See the next section, Reset Command, for more information.

See also Requirements for Reading Array Data in the Device Bus Operations section for more information. The Read-Only Operations—AC Characteristics on [page 73](#) provide the read parameters, and [Figure 13, on page 74](#) shows the timing diagram.

### Reset Command

Writing the reset command resets the device to the read or erase-suspend-read mode. Address bits are don't cares for this command.

The reset command may be written between the sequence cycles in an erase command sequence before erasing begins. This resets the device to the read mode. Once erasure begins, however, the device ignores reset commands until the operation is complete.

The reset command may be written between the sequence cycles in a program command sequence before programming begins. This resets the device to the read mode. If the program command sequence is written while the device is in the Erase Suspend mode, writing the reset command returns the device to the erase-suspend-read mode. Once programming begins, however, the device ignores reset commands until the operation is complete.

The reset command may be written between the sequence cycles in an autoselect command sequence. Once in the autoselect mode, the reset command must be written to return to the read mode. If the device entered the autoselect mode while in the Erase Suspend mode, writing the reset command returns the device to the erase-suspend-read mode.

If DQ5 goes high during a program or erase operation, writing the reset command returns the device to the read mode (or erase-suspend-read mode if the device was in Erase Suspend).

Note that if DQ1 goes high during a Write Buffer Programming operation, the system must write the Write-to-Buffer-Abort Reset command sequence to reset the device for the next operation.

## Autoselect Command Sequence

The autoselect command sequence allows the host system to read several identifier codes at specific addresses:

Identifier Code	A7:A0 (x16)	A6:A-1 (x8)
Manufacturer ID	00h	00h
Device ID, Cycle 1	01h	02h
Device ID, Cycle 2	0Eh	1Ch
Device ID, Cycle 3	0Fh	1Eh
Secured Silicon Sector Factory Protect	03h	06h
Sector Protect Verify	(SA)02h	(SA)04h

**Note:** The device ID is read over three cycles. SA = Sector Address

The autoselect command sequence is initiated by first writing two unlock cycles. This is followed by a third write cycle that contains the autoselect command. The device then enters the autoselect mode. The system may read at any address any number of times without initiating another autoselect command sequence:

The system must write the reset command to return to the read mode (or erase-suspend-read mode if the device was previously in Erase Suspend).

## Enter/Exit Secured Silicon Sector Command Sequence

The Secured Silicon Sector region provides a secured data area containing an 8-word/16-byte random Electronic Serial Number (ESN). The system can access the Secured Silicon Sector region by issuing the three-cycle Enter Secured Silicon Sector command sequence. The device continues to access the Secured Silicon Sector region until the system issues the four-cycle Exit Secured Silicon Sector command sequence. The Exit Secured Silicon Sector command sequence returns the device to normal operation. [Table 30 on page 61](#) and [Table 31 on page 62](#) show the address and data requirements for both command sequences. See also [Secured Silicon Sector Flash Memory Region on page 45](#) for further information. *Note that the ACC function and unlock bypass modes are not available when the Secured Silicon Sector is enabled.*

## Word Program Command Sequence

Programming is a four-bus-cycle operation. The program command sequence is initiated by writing two unlock write cycles, followed by the program set-up command. The program address and data are written next, which in turn initiate the Embedded Program algorithm. The system is not required to provide further controls or timings. The device automatically provides internally generated program pulses and verifies the programmed cell margin. [Table 30 on page 61](#) and [Table 31 on page 62](#) show the address and data requirements for the word program command sequence, respectively.

When the Embedded Program algorithm is complete, the device then returns to the read mode and addresses are no longer latched. The system can determine the status of the program operation by using DQ7 or DQ6. Refer to the Write Operation Status section for information on these status bits. Any commands written to the device during the Embedded Program Algorithm are ignored. *Note that the Secured Silicon Sector, autoselect, and CFI functions are unavailable when a program operation is in progress.* Note that a **hardware reset** immediately terminates the program operation. The program command sequence should be reinitiated once the device returns to the read mode, to ensure data integrity.

Programming is allowed in any sequence of address locations and across sector boundaries. Programming to the same word address multiple times without intervening erases (incremental bit programming) requires a modified programming method. For such application requirements, please contact your local Spansion representative. Word programming is supported for backward compatibility with existing Flash driver software and for occasional writing of individual words. Use of write buffer programming (see below) is strongly recommended for general programming use when more than a few words are to be programmed. The effective word programming time using write buffer programming is approximately four times shorter than the single word programming time.

**Any bit in a word cannot be programmed from 0 back to a 1.** Attempting to do so may cause the device to set DQ5=1, or cause DQ7 and DQ6 status bits to indicate the operation was successful. However, a succeeding read shows that the data is still 0. Only erase operations can convert a 0 to a 1.

### Unlock Bypass Command Sequence

The unlock bypass feature allows the system to program words to the device faster than using the standard program command sequence. The unlock bypass command sequence is initiated by first writing two unlock cycles. This is followed by a third write cycle containing the unlock bypass command, 20h. The device then enters the unlock bypass mode. A two-cycle unlock bypass mode command sequence is all that is required to program in this mode. The first cycle in this sequence contains the unlock bypass program command, A0h; the second cycle contains the program address and data. Additional data is programmed in the same manner. This mode dispenses with the initial two unlock cycles required in the standard program command sequence, resulting in faster total programming time. [Table 30 on page 61](#) and [Table 31 on page 62](#) show the requirements for the command sequence.

During the unlock bypass mode, only the Unlock Bypass Program and Unlock Bypass Reset commands are valid. To exit the unlock bypass mode, the system must issue the two-cycle unlock bypass reset command sequence. The first cycle must contain the data 90h. The second cycle must contain the data 00h. The device then returns to the read mode.

### Write Buffer Programming

Write Buffer Programming allows the system write to a maximum of 16 words/32 bytes in one programming operation. This results in faster effective programming time than the standard programming algorithms. The Write Buffer Programming command sequence is initiated by first writing two unlock cycles. This is followed by a third write cycle containing the Write Buffer Load command written at the Sector Address in which programming occurs. The fourth cycle

writes the sector address and the number of word locations, minus one, to be programmed. For example, if the system programs six unique address locations, then 05h should be written to the device. This tells the device how many write buffer addresses are loaded with data and therefore when to expect the Program Buffer to Flash command. The number of locations to program cannot exceed the size of the write buffer or the operation aborts.

The fifth cycle writes the first address location and data to be programmed. The write-buffer-page is selected by address bits  $A_{MAX}-A_4$ . All subsequent address/data pairs must fall within the selected-write-buffer-page. The system then writes the remaining address/data pairs into the write buffer. Write buffer locations may be loaded in any order.

The write-buffer-page address must be the same for all address/data pairs loaded into the write buffer. (This means Write Buffer Programming cannot be performed across multiple write-buffer pages.) This also means that Write Buffer Programming cannot be performed across multiple sectors. If the system attempts to load programming data outside of the selected write-buffer page, the operation aborts.

Note that if a Write Buffer address location is loaded multiple times, the address/data pair counter is decremented for every data load operation. The host system must therefore account for loading a write-buffer location more than once. The counter decrements for each data load operation, not for each unique write-buffer-address location. Note also that if an address location is loaded more than once into the buffer, the final data loaded for that address is programmed.

Once the specified number of write buffer locations are loaded, the system must then write the Program Buffer to Flash command at the sector address. Any other address and data combination aborts the Write Buffer Programming operation. The device then begins programming. Data polling should be used while monitoring the last address location loaded into the write buffer. DQ7, DQ6, DQ5, and DQ1 should be monitored to determine the device status during Write Buffer Programming.

The write-buffer programming operation can be suspended using the standard program suspend/resume commands. Upon successful completion of the Write Buffer Programming operation, the device is ready to execute the next command.

The Write Buffer Programming Sequence can be aborted in the following ways:

- Load a value that is greater than the page buffer size during the Number of Locations to Program step.
- Write to an address in a sector different than the one specified during the Write-Buffer-Load command.
- Write an Address/Data pair to a different write-buffer-page than the one selected by the Starting Address during the write buffer data loading stage of the operation.
- Write data other than the Confirm Command after the specified number of data load cycles.

The abort condition is indicated by  $DQ1 = 1$ ,  $DQ7 = DATA\#$  (for the last address location loaded),  $DQ6 = \text{toggle}$ , and  $DQ5 = 0$ . A Write-to-Buffer-Abort Reset command sequence must be written to reset the device for the next operation.

*Note that the Secured Silicon Sector, autoselect, and CFI functions are unavailable when a program operation is in progress.* This flash device is capable of handling multiple write buffer programming operations on the same write buffer address range without intervening erases. For applications requiring incremental

bit programming, a modified programming method is required; please contact your local Spansion representative. **Any bit in a write buffer address range cannot be programmed from 0 back to a 1.** Attempting to do so may cause the device to set DQ5=1, or cause the DQ7 and DQ6 status bits to indicate the operation was successful. However, a succeeding read shows that the data is still 0. Only erase operations can convert a 0 to a 1.

### Accelerated Program

The device offers accelerated program operations through the WP#/ACC or ACC pin depending on the particular product. When the system asserts  $V_{HH}$  on the WP#/ACC or ACC pin. The device uses the higher voltage on the WP#/ACC or ACC pin to accelerate the operation. *Note that the WP#/ACC pin must not be at  $V_{HH}$  for operations other than accelerated programming, or device damage may result. WP# contains an internal pullup; when unconnected, WP# is at  $V_{IH}$ .*

[Figure 3, on page 55](#) illustrates the algorithm for the program operation. Refer to the Erase and Program Operations—[AC Characteristics on page 73](#) for parameters, and [Figure 14, on page 75](#) for timing diagrams.



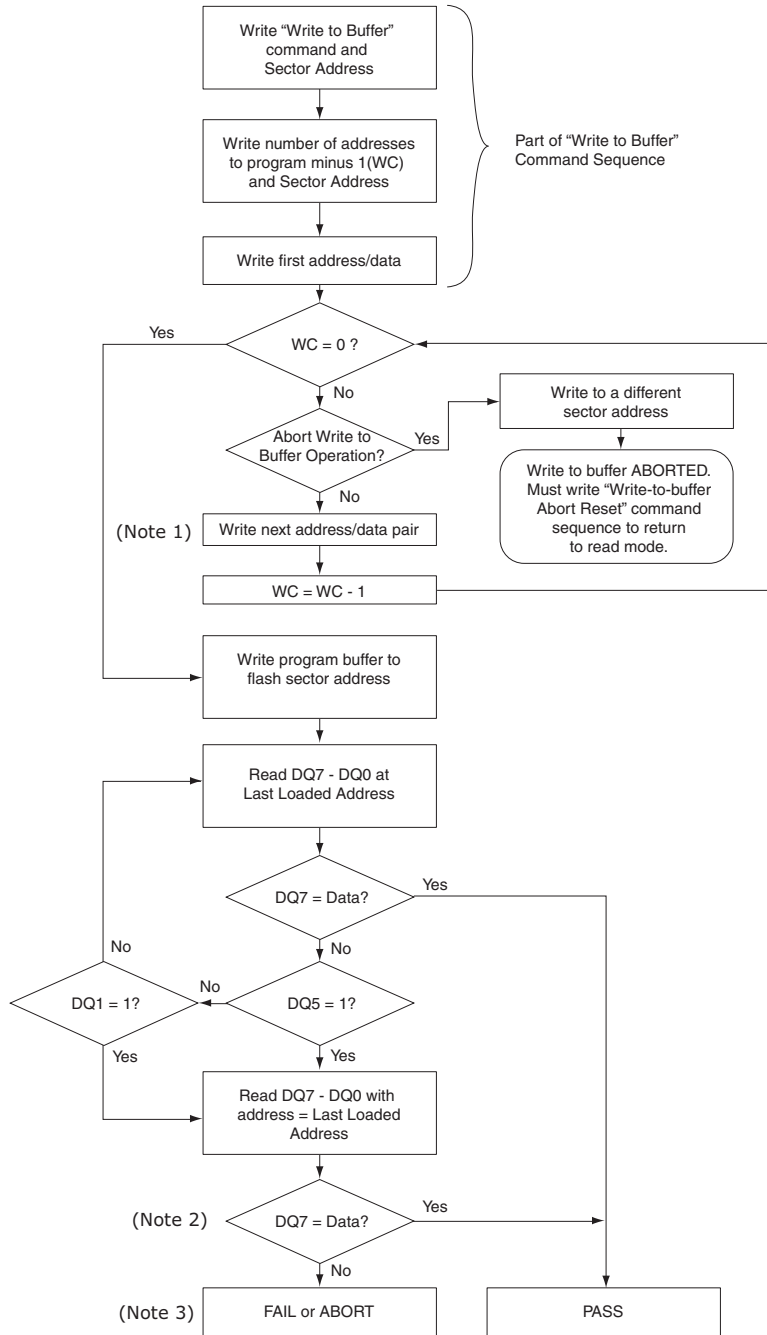

**Notes:**

1. When Sector Address is specified, any address in the selected sector is acceptable. However, when loading Write-Buffer address locations with data, all addresses must fall within the selected Write-Buffer Page.
2. DQ7 may change simultaneously with DQ5. Therefore, DQ7 should be verified.
3. If this flowchart location was reached because DQ5= 1, then the device FAILED. If this flowchart location was reached because DQ1= 1, then the Write to Buffer operation was ABORTED. In either case, the proper reset command must be written before the device can begin another operation. If DQ1= 1, write the Write-Buffer-Programming-Abort-Reset command. If DQ5= 1, write the Reset command.
4. See Table 30 on page 61 and Table 31 on page 62 for command sequences required for write buffer programming.

**Figure 3. Write Buffer Programming Operation**

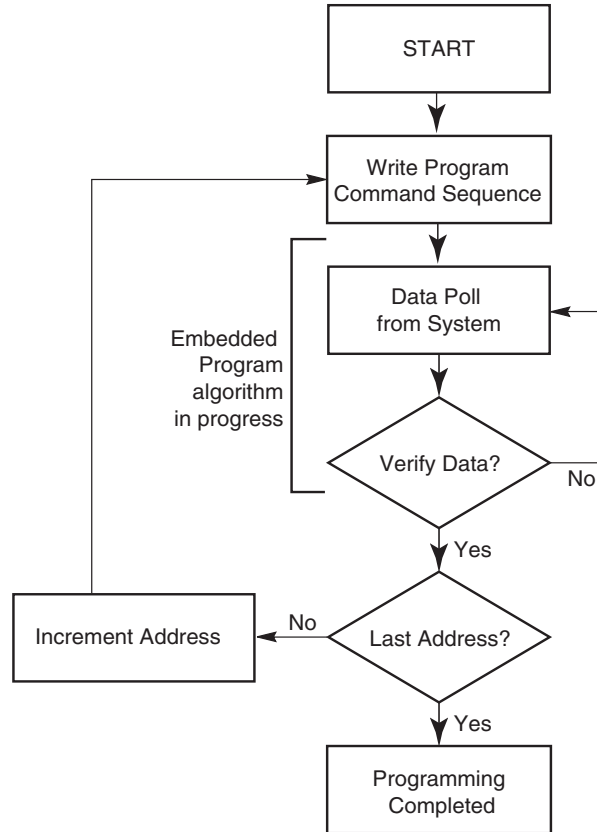

*Note:* See [Table 30 on page 61](#) and [Table 31 on page 62](#) for program command sequence.

**Figure 4. Program Operation**

### Program Suspend/Program Resume Command Sequence

The Program Suspend command allows the system to interrupt a programming operation or a Write to Buffer programming operation so that data can be read from any non-suspended sector. When the Program Suspend command is written during a programming process, the device halts the program operation within 15  $\mu$ s maximum (5 $\mu$ s typical) and updates the status bits. Addresses are not required when writing the Program Suspend command.

After the programming operation is suspended, the system can read array data from any non-suspended sector. The Program Suspend command may also be issued during a programming operation while an erase is suspended. In this case, data may be read from any addresses not in Erase Suspend or Program Suspend. If a read is needed from the Secured Silicon Sector area (One-time Program area), then user must use the proper command sequences to enter and exit this region. Note that the Secured Silicon Sector, autoselect, and CFI functions are unavailable when a program operation is in progress.

The system may also write the autoselect command sequence when the device is in the Program Suspend mode. The system can read as many autoselect codes as required. When the device exits the autoselect mode, the device reverts to the Program Suspend mode, and is ready for another valid operation. See [Autoselect Command Sequence on page 51](#) for more information.

After the Program Resume command is written, the device reverts to programming. The system can determine the status of the program operation using the

DQ7 or DQ6 status bits, just as in the standard program operation. See [Write Operation Status on page 63](#) for more information.

The system must write the Program Resume command (address bits are don't care) to exit the Program Suspend mode and continue the programming operation. Further writes of the Resume command are ignored. Another Program Suspend command can be written after the device resumes programming.

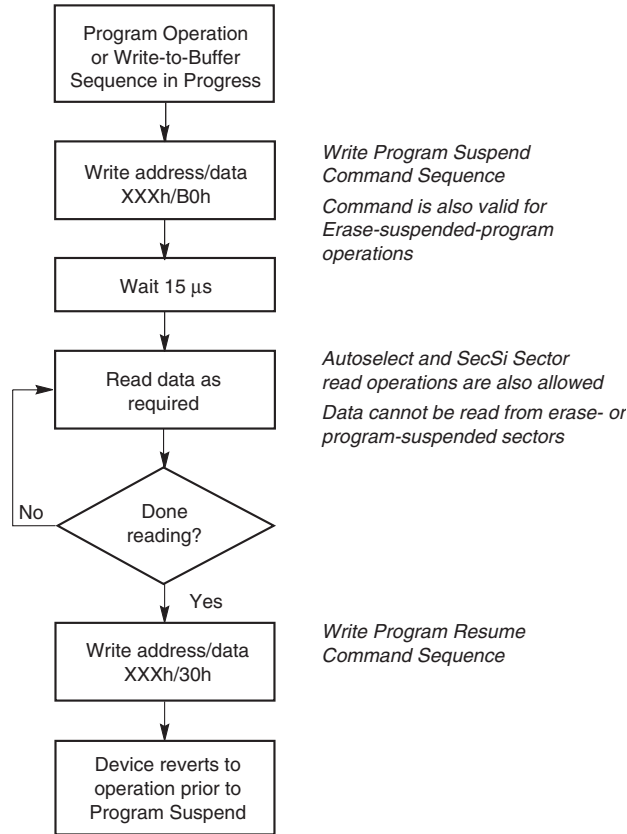

**Figure 5. Program Suspend/Program Resume**

## Chip Erase Command Sequence

Chip erase is a six bus cycle operation. The chip erase command sequence is initiated by writing two unlock cycles, followed by a set-up command. Two additional unlock write cycles are then followed by the chip erase command, which in turn invokes the Embedded Erase algorithm. The device does *not* require the system to preprogram prior to erase. The Embedded Erase algorithm automatically preprograms and verifies the entire memory for an all zero data pattern prior to electrical erase. The system is not required to provide any controls or timings during these operations. [Table 30 on page 61](#) and [Table 31 on page 62](#) show the address and data requirements for the chip erase command sequence.

When the Embedded Erase algorithm is complete, the device returns to the read mode and addresses are no longer latched. The system can determine the status of the erase operation by using DQ7, DQ6, or DQ2. Refer to [Write Operation Status on page 63](#) for information on these status bits.

Any commands written during the chip erase operation are ignored. However, note that a **hardware reset** immediately terminates the erase operation. If this

occurs, the chip erase command sequence should be reinitiated once the device returns to reading array data, to ensure data integrity.

Figure 6, on page 59 illustrates the algorithm for the erase operation. Refer to Table 38 on page 76 for parameters, and Figure 18, on page 80 for timing diagrams.

## Sector Erase Command Sequence

Sector erase is a six bus cycle operation. The sector erase command sequence is initiated by writing two unlock cycles, followed by a set-up command. Two additional unlock cycles are written, and are then followed by the address of the sector to be erased, and the sector erase command. Table 30 on page 61 and Table 31 on page 62 shows the address and data requirements for the sector erase command sequence.

The device does *not* require the system to preprogram prior to erase. The Embedded Erase algorithm automatically programs and verifies the entire memory for an all zero data pattern prior to electrical erase. The system is not required to provide any controls or timings during these operations.

After the command sequence is written, a sector erase time-out of 50  $\mu$ s occurs. During the time-out period, additional sector addresses and sector erase commands may be written. Loading the sector erase buffer may be done in any sequence, and the number of sectors may be from one sector to all sectors. The time between these additional cycles must be less than 50  $\mu$ s, otherwise erasure may begin. Any sector erase address and command following the exceeded time-out may or may not be accepted. It is recommended that processor interrupts be disabled during this time to ensure all commands are accepted. The interrupts can be re-enabled after the last Sector Erase command is written. **Any command other than Sector Erase or Erase Suspend during the time-out period resets the device to the read mode. Note that the Secured Silicon Sector, autoselect, and CFI functions are unavailable when an erase operation is in progress.** The system must rewrite the command sequence and any additional addresses and commands.

The system can monitor DQ3 to determine if the sector erase timer has timed out (See the section on DQ3: Sector Erase Timer.). The time-out begins from the rising edge of the final WE# pulse in the command sequence.

When the Embedded Erase algorithm is complete, the device returns to reading array data and addresses are no longer latched. The system can determine the status of the erase operation by reading DQ7, DQ6, or DQ2 in the erasing sector. Refer to the Write Operation Status section for information on these status bits.

Once the sector erase operation begins, only the Erase Suspend command is valid. All other commands are ignored. However, note that a **hardware reset** immediately terminates the erase operation. If that occurs, the sector erase command sequence should be reinitiated once the device returns to reading array data, to ensure data integrity.

Figure 6, on page 59 illustrates the algorithm for the erase operation. Refer to Table 38 on page 76 for parameters, and Figure 18, on page 80 for timing diagrams.

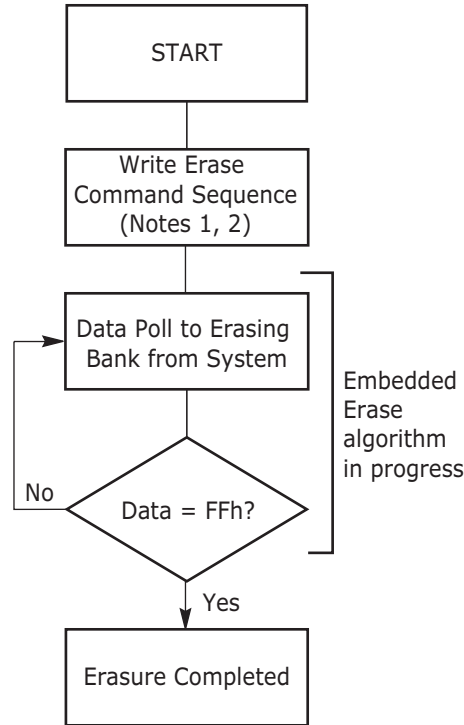
**Notes:**

1. See [Table 30](#) and [Table 31](#) for program command sequence.
2. See the section on [DQ3](#) for information on the sector erase timer.

**Figure 6. Erase Operation****Erase Suspend/Erase Resume Commands**

The Erase Suspend command, B0h, allows the system to interrupt a sector erase operation and then read data from, or program data to, any sector not selected for erasure. This command is valid only during the sector erase operation, including the 50  $\mu$ s time-out period during the sector erase command sequence. The Erase Suspend command is ignored if written during the chip erase operation or Embedded Program algorithm.

When the Erase Suspend command is written during the sector erase operation, the device requires a typical of 5  $\mu$ s (maximum of 20  $\mu$ s) to suspend the erase operation. However, when the Erase Suspend command is written during the sector erase time-out, the device immediately terminates the time-out period and suspends the erase operation.

After the erase operation is suspended, the device enters the erase-suspend-read mode. The system can read data from or program data to any sector not selected for erasure. (The device *erase suspends* all sectors selected for erasure.) Reading at any address within erase-suspended sectors produces status information on DQ7–DQ0. The system can use DQ7, or DQ6 and DQ2 together, to determine if a sector is actively erasing or is erase-suspended. Refer to [Write Operation Status on page 63](#) for information on these status bits.

After an erase-suspended program operation is complete, the device returns to the erase-suspend-read mode. The system can determine the status of the program operation using the DQ7 or DQ6 status bits, just as in the standard word program operation. Refer to [Write Operation Status on page 63](#) for more information.

In the erase-suspend-read mode, the system can also issue the autoselect command sequence. Refer to the [Autoselect Mode on page 37](#) and [Autoselect Command Sequence on page 51](#) sections for details.

To resume the sector erase operation, the system must write the Erase Resume command. Further writes of the Resume command are ignored. Another Erase Suspend command can be written after the chip resumes erasing.

**Note:**

*During an erase operation, this flash device performs multiple internal operations which are invisible to the system. When an erase operation is suspended, any of the internal operations that were not fully completed must be restarted. As such, if this flash device is continually issued suspend/resume commands in rapid succession, erase progress is impeded as a function of the number of suspends. The result is a longer cumulative erase time than without suspends. Note that the additional suspends do not affect device reliability or future performance. In most systems rapid erase/suspend activity occurs only briefly. In such cases, erase performance is not significantly impacted.*

## Command Definitions

**Table 30. Command Definitions (x16 Mode, BYTE# = V<sub>IH</sub>)**

Command Sequence (Note 1)	Cycles	Bus Cycles (Notes 2–5)												
		First		Second		Third		Fourth		Fifth		Sixth		
Read (Note 5)	1	RA	RD											
Reset (Note 6)	1	XXX	FO											
Autoselect (Note 7)	Manufacturer ID	4	555	AA	2AA	55	555	90	X00	0001				
	Device ID (Note 8)	6	555	AA	2AA	55	555	90	X01	227E	X0E (Note 19)	X0F (Note 19)		
	Device ID (Note 9)	4	555	AA	2AA	55	555	90	X01	(Note 18)				
	Secured Silicon Sector Factory Protect	4	555	AA	2AA	55	555	90	X03	(Note 10)				
	Sector Group Protect Verify (Note 11)	4	555	AA	2AA	55	555	90	(SA)X02	00/01				
Enter Secured Silicon Sector Region	3	555	AA	2AA	55	555	88							
Exit Secured Silicon Sector Region	4	555	AA	2AA	55	555	90	XXX	00					
Program	4	555	AA	2AA	55	555	A0	PA	PD					
Write to Buffer (Note 12)	3	555	AA	2AA	55	SA	25	SA	WC	PA	PD	WBL	PD	
Program Buffer to Flash	1	SA	29											
Write to Buffer Abort Reset (Note 13)	3	555	AA	2AA	55	555	F0							
Unlock Bypass	3	555	AA	2AA	55	555	20							
Unlock Bypass Program (Note 14)	2	XXX	A0	PA	PD									
Unlock Bypass Reset (Note 15)	2	XXX	90	XXX	00									
Chip Erase	6	555	AA	2AA	55	555	80	555	AA	2AA	55	555	10	
Sector Erase	6	555	AA	2AA	55	555	80	555	AA	2AA	55	SA	30	
Program/Erase Suspend (Note 16)	1	XXX	B0											
Program/Erase Resume (Note 17)	1	XXX	30											
CFI Query (Note 18)	1	55	98											

### Legend:

X = Don't care

RA = Read Address of memory location to be read.

RD = Read Data read from location RA during read operation.

PA = Program Address. Addresses latch on falling edge of WE# or CE# pulse, whichever happens later.

PD = Program Data for location PA. Data latches on rising edge of WE# or CE# pulse, whichever happens first.

SA = Sector Address of sector to be verified (in autoselect mode) or erased. Address bits A21–A15 uniquely select any sector.

WBL = Write Buffer Location. Address must be within same write buffer page as PA.

WC = Word Count. Number of write buffer locations to load minus 1.

### Notes:

- See Table 4 on page 19 for description of bus operations.
- All values are in hexadecimal.
- Shaded cells indicate read cycles. All others are write cycles.
- During unlock and command cycles, when lower address bits are 555 or 2AA as shown in table, address bits above A11 and data bits above DQ7 are don't care.
- No unlock or command cycles required when device is in read mode.
- Reset command is required to return to read mode (or to erase-suspend-read mode if previously in Erase Suspend) when device is in autoselect mode, or if DQ5 goes high while device is providing status information.
- Fourth cycle of the autoselect command sequence is a read cycle. Data bits DQ15–DQ8 are don't care. Except for RD, PD and WC. See Autoselect Command Sequence on page 51 for more information.
- For S29GL064A and S29GL032A, Device ID must be read in three cycles.
- For S29GL016A, Device ID must be read in one cycle.
- Refer to Table 15 on page 38 for data indicating Secured Silicon Sector factory protect status.
- Data is 00h for an unprotected sector group and 01h for a protected sector group.
- Total number of cycles in command sequence is determined by number of words written to write buffer. Maximum number of cycles in command sequence is 21, including Program Buffer to Flash command.
- Command sequence resets device for next command after aborted write-to-buffer operation.
- Unlock Bypass command is required prior to Unlock Bypass Program command.
- Unlock Bypass Reset command is required to return to read mode when device is in unlock bypass mode.
- System may read and program in non-erasing sectors, or enter autoselect mode, when in Erase Suspend mode. Erase Suspend command is valid only during a sector erase operation.
- Erase Resume command is valid only during Erase Suspend mode.
- Command is valid when device is ready to read array data or when device is in autoselect mode.
- Refer to Table 15 on page 38, for individual Device IDs per device density and model number.

**Table 3I. Command Definitions (x8 Mode, BYTE# = V<sub>IL</sub>)**

Command Sequence (Note 1)	Cycles	Bus Cycles (Notes 2–5)												
		First		Second		Third		Fourth		Fifth		Sixth		
		Addr	Data	Addr	Data	Addr	Data	Addr	Data	Addr	Data	Addr	Data	
Read (Note 6)	1	RA	RD											
Reset (Note 7)	1	XXX	F0											
Autoselect (Note 8)	Manufacturer ID	4	AAA	AA	555	55	AAA	90	X00	01				
	Device ID (Note 9)	6	AAA	AA	555	55	AAA	90	X02	7E	X1C	(Note 18)	X1E	(Note 18)
	Device ID (Note 10)	4	AAA	AA	555	55	AAA	90	X02	(Note 11)				
	Secured Silicon Sector Factory Protect	4	AAA	AA	555	55	AAA	90	X06	(Note 10)				
	Sector Group Protect Verify (Note 12)	4	AAA	AA	555	55	AAA	90	(SA)X04	00/01				
Enter Secured Silicon Sector Region	3	AAA	AA	555	55	AAA	88							
Exit Secured Silicon Sector Region	4	AAA	AA	555	55	AAA	90	XXX	00					
Write to Buffer (Note 13)	3	AAA	AA	555	55	SA	25	SA	BC	PA	PD	WBL	PD	
Program Buffer to Flash	1	SA	29											
Write to Buffer Abort Reset (Note 14)	3	AAA	AA	555	55	AAA	F0							
Chip Erase	6	AAA	AA	555	55	AAA	80	AAA	AA	555	55	AAA	10	
Sector Erase	6	AAA	AA	555	55	AAA	80	AAA	AA	555	55	SA	30	
Program/Erase Suspend (Note 15)	1	XXX	B0											
Program/Erase Resume (Note 16)	1	XXX	30											
CFI Query (Note 17)	1	AA	98											

**Legend:**

X = Don't care

RA = Read Address of memory location to be read.

RD = Read Data read from location RA during read operation.

PA = Program Address. Addresses latch on falling edge of WE# or CE# pulse, whichever happens later.

PD = Program Data for location PA. Data latches on rising edge of WE# or CE# pulse, whichever happens first.

SA = Sector Address of sector to be verified (in autoselect mode) or erased. Address bits A21–A15 uniquely select any sector.

WBL = Write Buffer Location. Address must be within same write buffer page as PA.

BC = Byte Count. Number of write buffer locations to load minus 1.

**Notes:**

- See Table 4 on page 19 for description of bus operations.
- All values are in hexadecimal.
- Shaded cells indicate read cycles. All others are write cycles.
- During unlock and command cycles, when lower address bits are 555 or AAA as shown in table, address bits above A11 are don't care.
- Unless otherwise noted, address bits A21–A11 are don't cares.
- No unlock or command cycles required when device is in read mode.
- Reset command is required to return to read mode (or to erase-suspend-read mode if previously in Erase Suspend) when device is in autoselect mode, or if DQ5 goes high while device is providing status information.
- Fourth cycle of autoselect command sequence is a read cycle. Data bits DQ15–DQ8 are don't care. See Autoselect Command Sequence on page 51 or more information.
- For S29GL064A and S29GL032A Device ID must be read in three cycles.
- For S29GL016A, Device ID must be read in one cycle.
- Refer to Table 15 on page 38, for data indicating Secured Silicon Sector factory protect status.
- Data is 00h for an unprotected sector group and 01h for a protected sector group.
- Total number of cycles in command sequence is determined by number of bytes written to write buffer. Maximum number of cycles in command sequence is 37, including Program Buffer to Flash command.
- Command sequence resets device for next command after aborted write-to-buffer operation.
- System may read and program in non-erasing sectors, or enter autoselect mode, when in Erase Suspend mode. Erase Suspend command is valid only during a sector erase operation.
- Erase Resume command is valid only during Erase Suspend mode.
- Command is valid when device is ready to read array data or when device is in autoselect mode.
- Refer to Table 15 on page 38, for individual Device IDs per device density and model number.



## Write Operation Status

The device provides several bits to determine the status of a program or erase operation: DQ2, DQ3, DQ5, DQ6, and DQ7. [Table 32 on page 68](#) and the following subsections describe the function of these bits. DQ7 and DQ6 each offer a method for determining whether a program or erase operation is complete or in progress. The device also provides a hardware-based output signal, RY/BY#, to determine whether an Embedded Program or Erase operation is in progress or is completed.

### DQ7: Data# Polling

The Data# Polling bit, DQ7, indicates to the host system whether an Embedded Program or Erase algorithm is in progress or completed, or whether the device is in Erase Suspend. Data# Polling is valid after the rising edge of the final WE# pulse in the command sequence.

During the Embedded Program algorithm, the device outputs on DQ7 the complement of the datum programmed to DQ7. This DQ7 status also applies to programming during Erase Suspend. When the Embedded Program algorithm is complete, the device outputs the datum programmed to DQ7. The system must provide the program address to read valid status information on DQ7. If a program address falls within a protected sector, Data# Polling on DQ7 is active for approximately 1  $\mu$ s, then the device returns to the read mode.

During the Embedded Erase algorithm, Data# Polling produces a 0 on DQ7. When the Embedded Erase algorithm is complete, or if the device enters the Erase Suspend mode, Data# Polling produces a 1 on DQ7. The system must provide an address within any of the sectors selected for erasure to read valid status information on DQ7.

After an erase command sequence is written, if all sectors selected for erasing are protected, Data# Polling on DQ7 is active for approximately 100  $\mu$ s, then the device returns to the read mode. If not all selected sectors are protected, the Embedded Erase algorithm erases the unprotected sectors, and ignores the selected sectors that are protected. However, if the system reads DQ7 at an address within a protected sector, the status may not be valid.

Just prior to the completion of an Embedded Program or Erase operation, DQ7 may change asynchronously with DQ0–DQ6 while Output Enable (OE#) is asserted low. That is, the device may change from providing status information to valid data on DQ7. Depending on when the system samples the DQ7 output, it may read the status or valid data. Even if the device completed the program or erase operation and DQ7 has valid data, the data outputs on DQ0–DQ6 may be still invalid. Valid data on DQ0–DQ7 appears on successive read cycles.

[Table 32 on page 68](#) shows the outputs for Data# Polling on DQ7. [Figure 7, on page 64](#) shows the Data# Polling algorithm. [Figure 19, on page 80](#) shows the Data# Polling timing diagram.

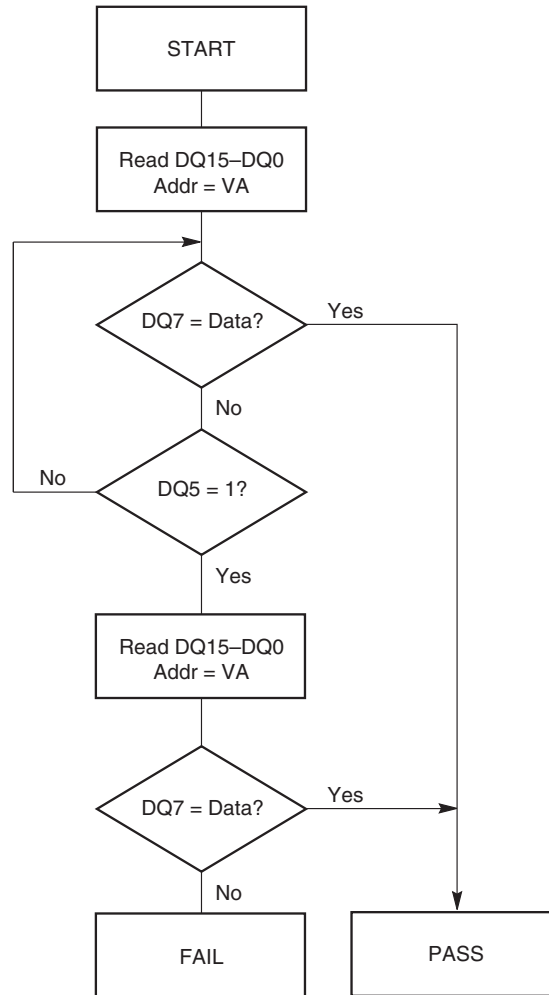

**Notes:**

1. VA = Valid address for programming. During a sector erase operation, a valid address is any sector address within the sector being erased. During chip erase, a valid address is any non-protected sector address.
2. DQ7 should be rechecked even if DQ5 = 1 because DQ7 may change simultaneously with DQ5.

**Figure 7. Data# Polling Algorithm**

**RY/BY#: Ready/Busy#**

The RY/BY# is a dedicated, open-drain output pin which indicates whether an Embedded Algorithm is in progress or complete. The RY/BY# status is valid after the rising edge of the final WE# pulse in the command sequence. Since RY/BY# is an open-drain output, several RY/BY# pins can be tied together in parallel with a pull-up resistor to V<sub>CC</sub>.

If the output is low (Busy), the device is actively erasing or programming. (This includes programming in the Erase Suspend mode.) If the output is high (Ready), the device is in the read mode, the standby mode, or in the erase-suspend-read mode. [Table 32 on page 68](#) shows the outputs for RY/BY#.

## DQ6: Toggle Bit I

Toggle Bit I on DQ6 indicates whether an Embedded Program or Erase algorithm is in progress or complete, or whether the device entered the Erase Suspend mode. Toggle Bit I may be read at any address, and is valid after the rising edge of the final WE# pulse in the command sequence (prior to the program or erase operation), and during the sector erase time-out.

During an Embedded Program or Erase algorithm operation, successive read cycles to any address cause DQ6 to toggle. The system may use either OE# or CE# to control the read cycles. When the operation is complete, DQ6 stops toggling.

After an erase command sequence is written, if all sectors selected for erasing are protected, DQ6 toggles for approximately 100  $\mu$ s, then returns to reading array data. If not all selected sectors are protected, the Embedded Erase algorithm erases the unprotected sectors, and ignores the selected sectors that are protected.

The system can use DQ6 and DQ2 together to determine whether a sector is actively erasing or is erase-suspended. When the device is actively erasing (that is, the Embedded Erase algorithm is in progress), DQ6 toggles. When the device enters the Erase Suspend mode, DQ6 stops toggling. However, the system must also use DQ2 to determine which sectors are erasing or erase-suspended. Alternatively, the system can use DQ7 (see the subsection on [DQ7: Data# Polling on page 63](#)).

If a program address falls within a protected sector, DQ6 toggles for approximately 1  $\mu$ s after the program command sequence is written, then returns to reading array data.

DQ6 also toggles during the erase-suspend-program mode, and stops toggling once the Embedded Program algorithm is complete.

[Table 32 on page 68](#) shows the outputs for Toggle Bit I on DQ6. [Figure 8, on page 66](#) shows the toggle bit algorithm. [Figure 20, on page 81](#) shows the toggle bit timing diagrams. [Figure 21, on page 81](#) shows the differences between DQ2 and DQ6 in graphical form. See also the subsection on [DQ2: Toggle Bit II on page 67](#).

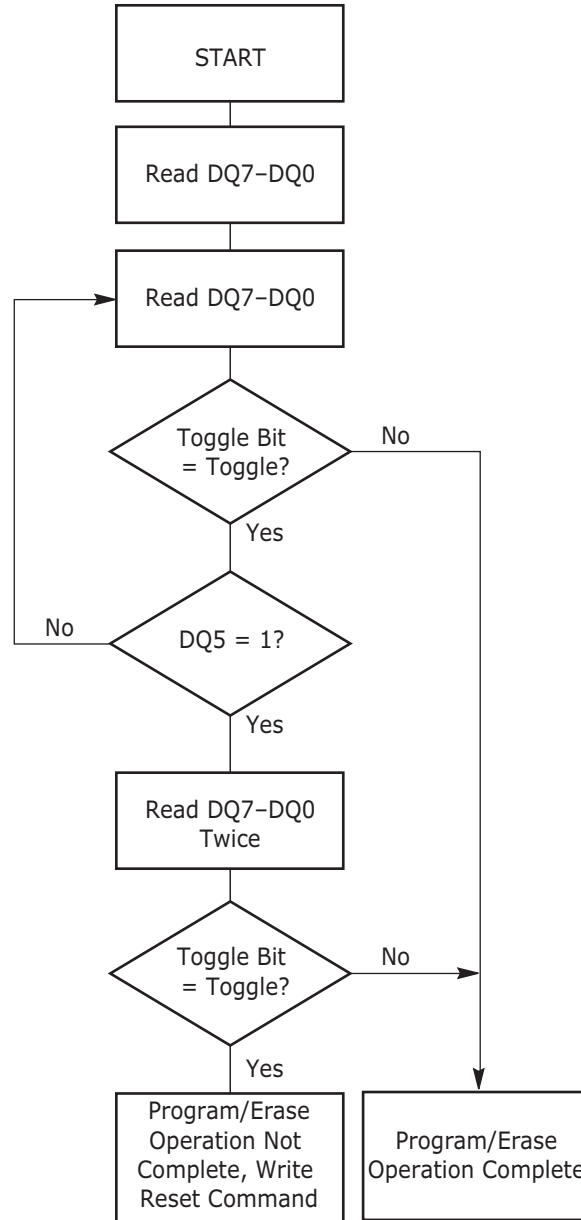

**Note:**

The system should recheck the toggle bit even if DQ5 = 1 because the toggle bit may stop toggling as DQ5 changes to 1. See the subsections on DQ6 and DQ2 for more information.

**Figure 8. Toggle Bit Algorithm**

## DQ2: Toggle Bit II

The “Toggle Bit II” on DQ2, when used with DQ6, indicates whether a particular sector is actively erasing (that is, the Embedded Erase algorithm is in progress), or whether that sector is erase-suspended. Toggle Bit II is valid after the rising edge of the final WE# pulse in the command sequence.

DQ2 toggles when the system reads at addresses within those sectors that were selected for erasure. (The system may use either OE# or CE# to control the read cycles.) But DQ2 cannot distinguish whether the sector is actively erasing or is erase-suspended. DQ6, by comparison, indicates whether the device is actively erasing, or is in Erase Suspend, but cannot distinguish which sectors are selected for erasure. Thus, both status bits are required for sector and mode information. Refer to [Table 32 on page 68](#) to compare outputs for DQ2 and DQ6.

[Figure 8, on page 66](#) shows the toggle bit algorithm in flowchart form, and the section “DQ2: Toggle Bit II” explains the algorithm. See also the RY/BY#: Ready/Busy# subsection. [Figure 20, on page 81](#) shows the toggle bit timing diagram. [Figure 21, on page 81](#) shows the differences between DQ2 and DQ6 in graphical form.

## Reading Toggle Bits DQ6/DQ2

Refer to [Figure 8, on page 66](#) for the following discussion. Whenever the system initially begins reading toggle bit status, it must read DQ7–DQ0 at least twice in a row to determine whether a toggle bit is toggling. Typically, the system would note and store the value of the toggle bit after the first read. After the second read, the system would compare the new value of the toggle bit with the first. If the toggle bit is not toggling, the device completed the program or erase operation. The system can read array data on DQ7–DQ0 on the following read cycle.

However, if after the initial two read cycles, the system determines that the toggle bit is still toggling, the system also should note whether the value of DQ5 is high (see the section on DQ5). If it is, the system should then determine again whether the toggle bit is toggling, since the toggle bit may have stopped toggling just as DQ5 went high. If the toggle bit is no longer toggling, the device successfully completed the program or erase operation. If it is still toggling, the device did not complete the operation successfully, and the system must write the reset command to return to reading array data.

The remaining scenario is that the system initially determines that the toggle bit is toggling and DQ5 has not gone high. The system may continue to monitor the toggle bit and DQ5 through successive read cycles, determining the status as described in the previous paragraph. Alternatively, it may choose to perform other system tasks. In this case, the system must start at the beginning of the algorithm when it returns to determine the status of the operation (top of [Figure 8, on page 66](#)).

## DQ5: Exceeded Timing Limits

DQ5 indicates whether the program, erase, or write-to-buffer time exceeded a specified internal pulse count limit. Under these conditions DQ5 produces a *1*, indicating that the program or erase cycle was not successfully completed.

The device may output a *1* on DQ5 if the system tries to program a *1* to a location that was previously programmed to *0*. **Only an erase operation can change a *0* back to a *1*.** Under this condition, the device halts the operation, and when the timing limit is exceeded, DQ5 produces a *1*.

In all these cases, the system must write the reset command to return the device to the reading the array (or to erase-suspend-read if the device was previously in the erase-suspend-program mode).

### DQ3: Sector Erase Timer

After writing a sector erase command sequence, the system may read DQ3 to determine whether or not erasure began. (The sector erase timer does not apply to the chip erase command.) If additional sectors are selected for erasure, the entire time-out also applies after each additional sector erase command. When the time-out period is complete, DQ3 switches from a 0 to a 1. If the time between additional sector erase commands from the system can be assumed to be less than 50 μs, the system need not monitor DQ3. See also the Sector Erase Command Sequence section.

After the sector erase command is written, the system should read the status of DQ7 (Data# Polling) or DQ6 (Toggle Bit 1) to ensure that the device accepted the command sequence, and then read DQ3. If DQ3 is 1, the Embedded Erase algorithm has begun; all further commands (except Erase Suspend) are ignored until the erase operation is complete. If DQ3 is 0, the device accepts additional sector erase commands. To ensure the command is accepted, the system software should check the status of DQ3 prior to and following each subsequent sector erase command. If DQ3 is high on the second status check, the last command might not have been accepted.

Table 32 on page 68 shows the status of DQ3 relative to the other status bits.

### DQ1: Write-to-Buffer Abort

DQ1 indicates whether a Write-to-Buffer operation was aborted. Under these conditions DQ1 produces a 1. The system must issue the Write-to-Buffer-Abort-Reset command sequence to return the device to reading array data. See Write Buffer on page 21 for more details.

**Table 32. Write Operation Status**

Status		DQ7 (Note 2)	DQ6	DQ5 (Note 1)	DQ3	DQ2 (Note 2)	DQ1	RY/BY#	
Standard Mode	Embedded Program Algorithm	DQ7#	Toggle	0	N/A	No toggle	0	0	
	Embedded Erase Algorithm	0	Toggle	0	1	Toggle	N/A	0	
Program Suspend Mode	Program-Suspend Read	Program-Suspended Sector	Invalid (not allowed)					1	
		Non-Program Suspended Sector	Data					1	
Erase Suspend Mode	Erase-Suspend Read	Erase-Suspended Sector	1	No toggle	0	N/A	Toggle	N/A	1
		Non-Erase Suspended Sector	Data					1	
		Erase-Suspend-Program (Embedded Program)	DQ7#	Toggle	0	N/A	N/A	N/A	0
Write-to-Buffer	Busy (Note 3)	DQ7#	Toggle	0	N/A	N/A	0	0	
	Abort (Note 4)	DQ7#	Toggle	0	N/A	N/A	1	0	

**Notes:**

1. DQ5 switches to 1 when an Embedded Program, Embedded Erase, or Write-to-Buffer operation exceeded the maximum timing limits. Refer to the section on DQ5 for more information.
2. DQ7 and DQ2 require a valid address when reading status information. Refer to the appropriate subsection for further details.
3. The Data# Polling algorithm should be used to monitor the last loaded write-buffer address location.
4. DQ1 switches to 1 when the device aborts the write-to-buffer operation.

## Absolute Maximum Ratings

Storage Temperature, Plastic Packages . . . . .	-65°C to +150°C
Ambient Temperature with Power Applied . . . . .	-65°C to +125°C
Voltage with Respect to Ground:	
$V_{CC}$ (Note 1) . . . . .	-0.5 V to +4.0 V
A9, OE#, ACC and RESET# (Note 2) . . . . .	-0.5 V to +12.5 V
All other pins (Note 1) . . . . .	-0.5 V to $V_{CC}+0.5$ V
Output Short Circuit Current (Note 3) . . . . .	200 mA

**Notes:**

1. Minimum DC voltage on input or I/Os is -0.5 V. During voltage transitions, inputs or I/Os may overshoot  $V_{SS}$  to -2.0 V for periods of up to 20 ns. See Figure 9, on page 69. Maximum DC voltage on input or I/Os is  $V_{CC} + 0.5$  V. During voltage transitions, input or I/O pins may overshoot to  $V_{CC} + 2.0$  V for periods up to 20 ns. See Figure 10, on page 69.
2. Minimum DC input voltage on pins A9, OE#, ACC, and RESET# is -0.5 V. During voltage transitions, A9, OE#, ACC, and RESET# may overshoot  $V_{SS}$  to -2.0 V for periods of up to 20 ns. See Figure 9, on page 69. Maximum DC input voltage on pin A9, OE#, ACC, and RESET# is +12.5 V which may overshoot to +14.0V for periods up to 20 ns.
3. No more than one output may be shorted to ground at a time. Duration of the short circuit should not be greater than one second.
4. Stresses above those listed under Absolute Maximum Ratings may cause permanent damage to the device. This is a stress rating only; functional operation of the device at these or any other conditions above those indicated in the operational sections of this data sheet is not implied. Exposure of the device to absolute maximum rating conditions for extended periods may affect device reliability.

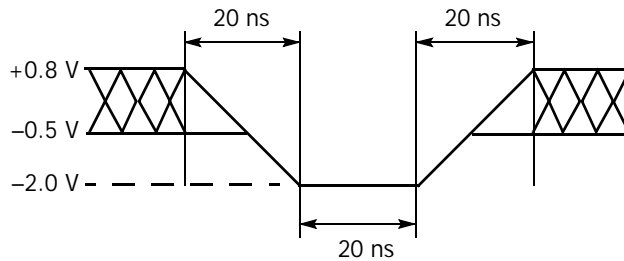

**Figure 9. Maximum Negative Overshoot Waveform**

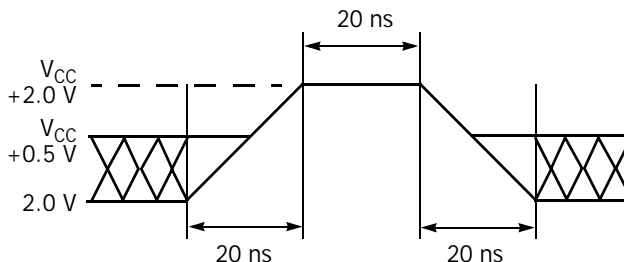

**Figure 10. Maximum Positive Overshoot Waveform**

## Operating Ranges

### Industrial (I) Devices

Ambient Temperature ( $T_A$ ) . . . . .  $-40^{\circ}\text{C}$  to  $+85^{\circ}\text{C}$

### Supply Voltages

$V_{CC}$  for full voltage range . . . . .  $+2.7\text{ V}$  to  $+3.6\text{ V}$

$V_{CC}$  for regulated voltage range. . . . .  $+3.0\text{ V}$  to  $+3.6\text{ V}$

$V_{IO}$  . . . . .  $V_{CC}$

*Note: Operating ranges define those limits between which the functionality of the device is guaranteed.*



## DC Characteristics

### CMOS Compatible

Parameter Symbol	Parameter Description (Notes)	Test Conditions	Min	Typ	Max	Unit	
$I_{LI}$	Input Load Current (Note 1)	$V_{IN} = V_{SS}$ to $V_{CC}$ , $V_{CC} = V_{CC\ max}$			$\pm 1.0$	$\mu A$	
$I_{LIT}$	A9, ACC Input Load Current	$V_{CC} = V_{CC\ max}$ ; A9 = 12.5 V	-40°C to 0°C		250	$\mu A$	
			0°C to 85°C		35		
$I_{LR}$	Reset Leakage Current	$V_{CC} = V_{CC\ max}$ ; RESET# = 12.5 V			35	$\mu A$	
$I_{LO}$	Output Leakage Current	$V_{OUT} = V_{SS}$ to $V_{CC}$ , $V_{CC} = V_{CC\ max}$			$\pm 1.0$	$\mu A$	
$I_{CC1}$	$V_{CC}$ Initial Read Current (Notes 2, 3)	CE# = $V_{IL}$ , OE# = $V_{IH}$	1 MHz		5	20	mA
			5 MHz		18	25	
			10 MHz		35	50	
$I_{CC2}$	$V_{CC}$ Intra-Page Read Current (Notes 2, 3)	CE# = $V_{IL}$ , OE# = $V_{IH}$	10 MHz		5	20	mA
			40 MHz		10	40	
$I_{CC3}$	$V_{CC}$ Active Write Current (Note 3)	CE# = $V_{IL}$ , OE# = $V_{IH}$		50	60	mA	
$I_{CC4}$	$V_{CC}$ Standby Current (Note 3)	CE#, RESET# = $V_{CC} \pm 0.3$ V, WP# = $V_{IH}$		1	5	$\mu A$	
$I_{CC5}$	$V_{CC}$ Reset Current (Note 3)	RESET# = $V_{SS} \pm 0.3$ V, WP# = $V_{IH}$		1	5	$\mu A$	
$I_{CC6}$	Automatic Sleep Mode (Notes 3, 5)	$V_{IH} = V_{CC} \pm 0.3$ V; $-0.1 < V_{IL} \leq 0.3$ V, WP# = $V_{IH}$		1	5	$\mu A$	
$V_{IL}$	Input Low Voltage 1 (Note 6)		-0.5		0.8	V	
$V_{IH}$	Input High Voltage 1 (Note 6)		$0.7 V_{CC}$		$V_{CC} + 0.5$	V	
$V_{HH}$	Voltage for ACC Program Acceleration	$V_{CC} = 2.7 - 3.6$ V	11.5	12.0	12.5	V	
$V_{ID}$	Voltage for Autoselect and Temporary Sector Unprotect	$V_{CC} = 2.7 - 3.6$ V	11.5	12.0	12.5	V	
$V_{OL}$	Output Low Voltage (Note 6)	$I_{OL} = 4.0$ mA, $V_{CC} = V_{CC\ min}$			0.45	V	
$V_{OH1}$	Output High Voltage	$I_{OH} = -2.0$ mA, $V_{CC} = V_{CC\ min}$	$0.85 V_{CC}$			V	
$V_{OH2}$		$I_{OH} = -100$ $\mu A$ , $V_{CC} = V_{CC\ min}$	$V_{CC} - 0.4$			V	
$V_{LKO}$	Low $V_{CC}$ Lock-Out Voltage (Note 7)		2.3		2.5	V	

#### Notes:

1. On the WP#/ACC pin only, the maximum input load current when WP# =  $V_{IL}$  is  $\pm 5.0$   $\mu A$ .
2. The  $I_{CC}$  current listed is typically less than 3.5 mA/MHz, with OE# at  $V_{IH}$ .
3. Maximum  $I_{CC}$  specifications are tested with  $V_{CC} = V_{CC\ max}$ .
4.  $I_{CC}$  active while Embedded Erase or Embedded Program is in progress.
5. Automatic sleep mode enables the low power mode when addresses remain stable for  $t_{ACC} + 30$  ns.
6.  $V_{CC}$  voltage requirements.
7. Not 100% tested.

## Test Conditions

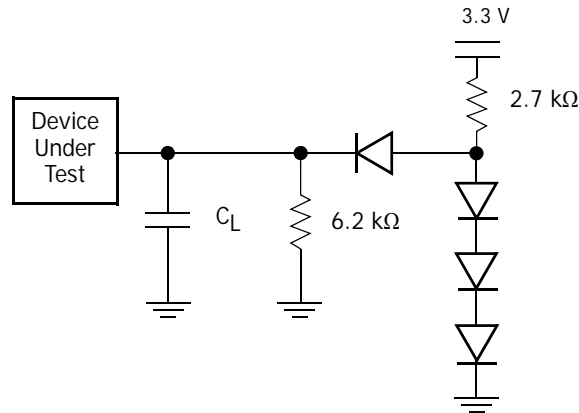

**Note:** Diodes are IN3064 or equivalent.

**Figure II. Test Setup**

**Table 33. Test Specifications**

Test Condition	All Speeds	Unit
Output Load	1 TTL gate	
Output Load Capacitance, $C_L$ (including jig capacitance)	30	pF
Input Rise and Fall Times	5	ns
Input Pulse Levels	0.0 or $V_{CC}$	V
Input timing measurement reference levels	0.5 $V_{CC}$	V
Output timing measurement reference levels	0.5 $V_{CC}$	V

## Key to Switching Waveforms

Waveform	Inputs	Outputs
	Steady	
	Changing from H to L	
	Changing from L to H	
	Don't Care, Any Change Permitted	Changing, State Unknown
	Does Not Apply	Center Line is High Impedance State (High Z)

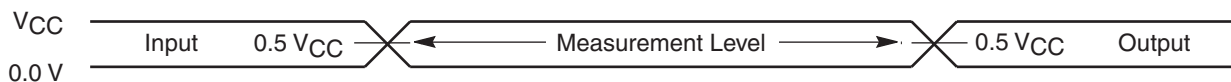

**Figure I2. Input Waveforms and Measurement Levels**

## AC Characteristics

**Table 34. Read-Only Operations-S29GL064A Only**

Parameter		Description	Test Setup		Speed Options			Unit
JEDEC	Std.				90	10	11	
$t_{AVAV}$	$t_{RC}$	Read Cycle Time (Note 1)		Min	90	100	110	ns
$t_{AVQV}$	$t_{ACC}$	Address to Output Delay	CE#, OE# = V <sub>IL</sub>	Max	90	100	110	ns
$t_{ELQV}$	$t_{CE}$	Chip Enable to Output Delay	OE# = V <sub>IL</sub>	Max	90	100	110	ns
	$t_{PACC}$	Page Access Time		Max	25	30	30	ns
$t_{GLQV}$	$t_{OE}$	Output Enable to Output Delay		Max	25	30	30	ns
$t_{EHQZ}$	$t_{DF}$	Chip Enable to Output High Z (Note 1)		Max	16			ns
$t_{GHQZ}$	$t_{DF}$	Output Enable to Output High Z (Note 1)		Max	16			ns
$t_{AXQX}$	$t_{OH}$	Output Hold Time From Addresses, CE# or OE#, Whichever Occurs First		Min	0			ns
	$t_{OEH}$	Output Enable Hold Time (Note 1)	Read	Min	0			ns
			Toggle and Data# Polling	Min	10			ns

**Notes:**

- Not 100% tested.
- See Figure 11, on page 72 and Table 33 on page 72 for test specifications

**Table 35. Read-Only Operations-S29GL032A Only**

Parameter		Description	Test Setup		Speed Options			Unit
JEDEC	Std.				90	10	11	
$t_{AVAV}$	$t_{RC}$	Read Cycle Time (Note 1)		Min	90	100	110	ns
$t_{AVQV}$	$t_{ACC}$	Address to Output Delay	CE#, OE# = V <sub>IL</sub>	Max	90	100	110	ns
$t_{ELQV}$	$t_{CE}$	Chip Enable to Output Delay	OE# = V <sub>IL</sub>	Max	90	100	110	ns
	$t_{PACC}$	Page Access Time		Max	25	30	30	ns
$t_{GLQV}$	$t_{OE}$	Output Enable to Output Delay		Max	25	30	30	ns
$t_{EHQZ}$	$t_{DF}$	Chip Enable to Output High Z (Note 1)		Max	16			ns
$t_{GHQZ}$	$t_{DF}$	Output Enable to Output High Z (Note 1)		Max	16			ns
$t_{AXQX}$	$t_{OH}$	Output Hold Time From Addresses, CE# or OE#, Whichever Occurs First		Min	0			ns
	$t_{OEH}$	Output Enable Hold Time (Note 1)	Read	Min	0			ns
			Toggle and Data# Polling	Min	10			ns

**Notes:**

- Not 100% tested.
- See Figure 11, on page 72 and Table 33 on page 72 for test specifications.

**Table 36. Read-Only Operation-S29GL016A Only**

Parameter		Description	Test Setup		Speed Options		Unit
JEDEC	Std.				90	10	
$t_{AVAV}$	$t_{RC}$	Read Cycle Time (Note 1)		Min	90	100	ns
$t_{AVQV}$	$t_{ACC}$	Address to Output Delay	CE#, OE# = $V_{IL}$	Max	90	100	ns
$t_{ELQV}$	$t_{CE}$	Chip Enable to Output Delay	OE# = $V_{IL}$	Max	90	100	ns
	$t_{PACC}$	Page Access Time		Max	25	30	ns
$t_{GLQV}$	$t_{OE}$	Output Enable to Output Delay		Max	25	30	ns
$t_{EHQZ}$	$t_{DF}$	Chip Enable to Output High Z (Note 1)		Max	16		ns
$t_{GHQZ}$	$t_{DF}$	Output Enable to Output High Z (Note 1)		Max	16		ns
$t_{AXQX}$	$t_{OH}$	Output Hold Time From Addresses, CE# or OE#, Whichever Occurs First		Min	0		ns
	$t_{OEh}$	Output Enable Hold Time (Note 1)	Read	Min	0		ns
		Toggle and Data# Polling		Min	10		ns

**Notes:**

1. Not 100% tested.
2. See Figure 11, on page 72 and Table 33 on page 72 for test specifications.

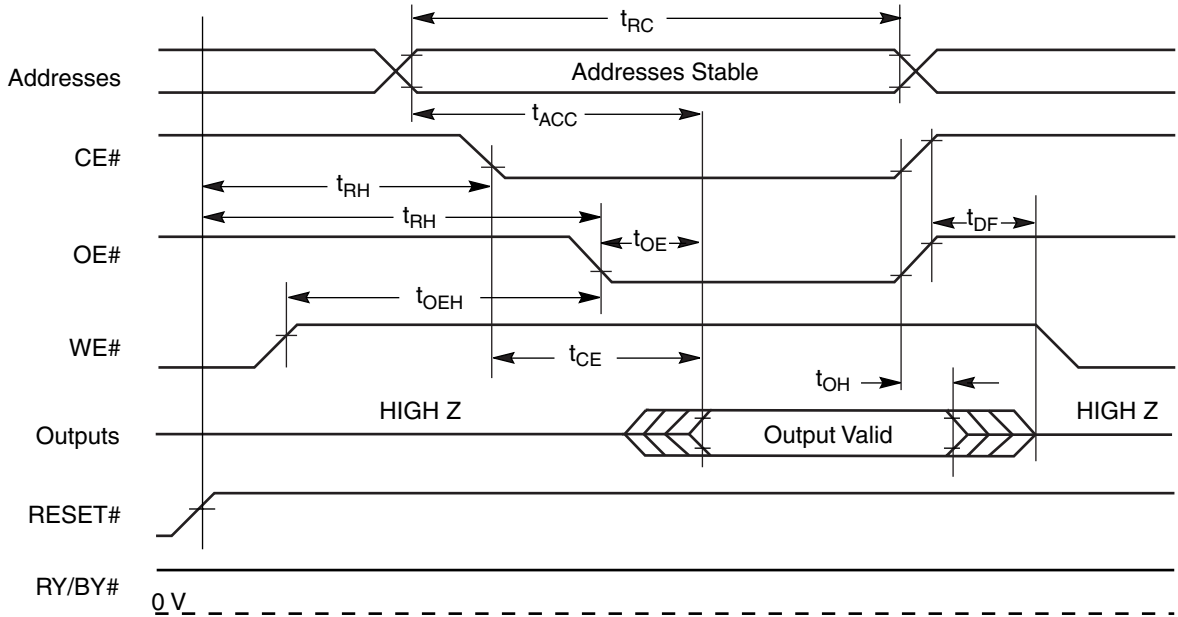

**Figure I3. Read Operation Timings**

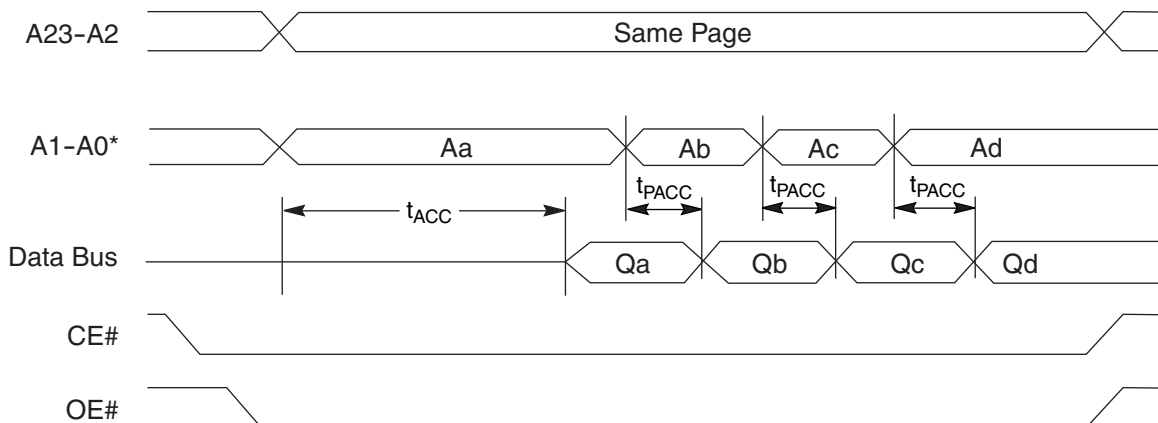

**Note:** \* Figure shows device in word mode. Addresses are A1-A-1 for byte mode.

Figure 14. Page Read Timings

Table 37. Hardware Reset (RESET#)

Parameter		Description		All Speed Options	Unit
JEDEC	Std.				
	$t_{Ready}$	RESET# Pin Low (During Embedded Algorithms) to Read Mode (See Note)	Max	20	$\mu$ s
	$t_{Ready}$	RESET# Pin Low (NOT During Embedded Algorithms) to Read Mode(See Note)	Max	500	ns
	$t_{RP}$	RESET# Pulse Width	Min	500	ns
	$t_{RH}$	Reset High Time Before Read (See Note)	Min	50	ns
	$t_{RPD}$	RESET# Input Low to Standby Mode (See Note)	Min	20	$\mu$ s
	$t_{RB}$	RY/BY# Output High to CE#, OE# pin Low	Min	0	ns

Note: Not 100% tested.

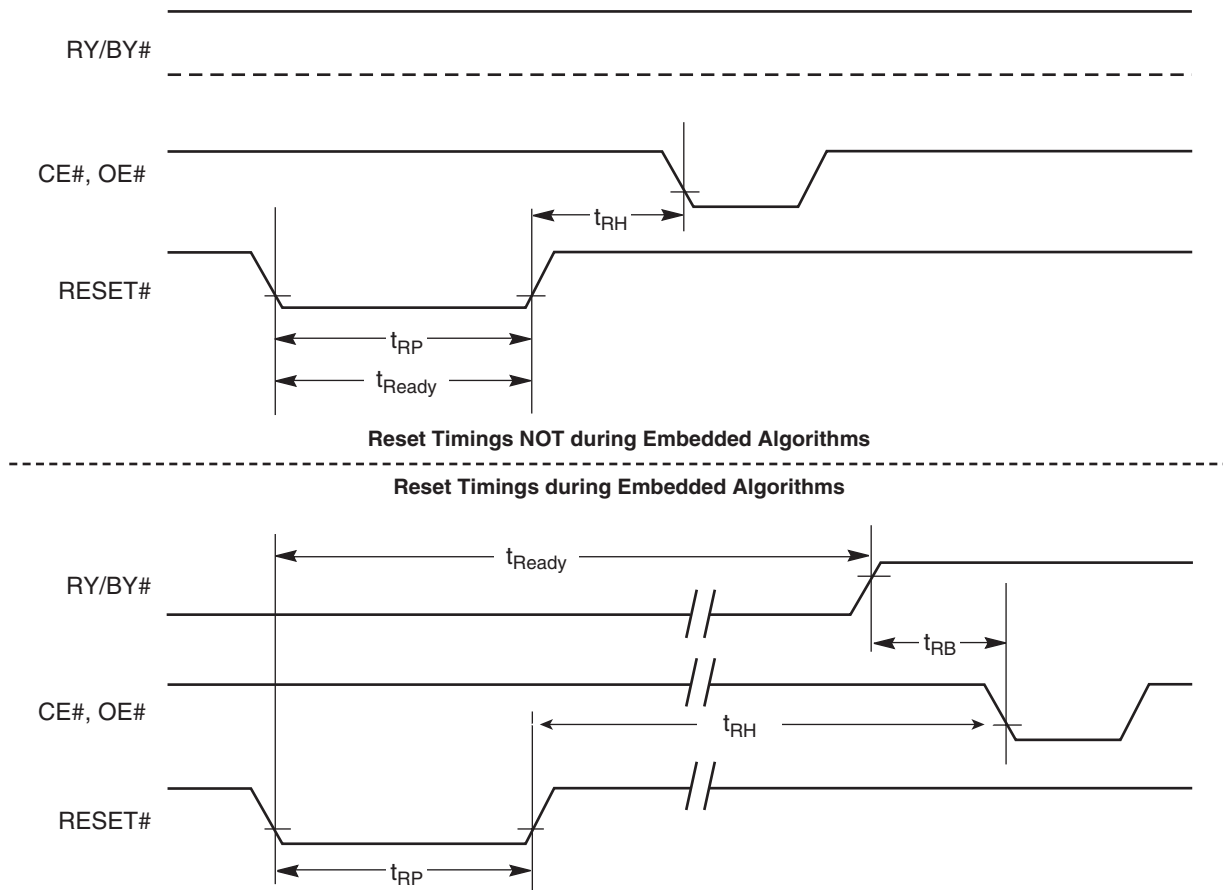

Notes:

1. Not 100% tested.
2. See the [Erase And Programming Performance on page 87](#) for more information.
3. For 1–16 words/1–32 bytes programmed.

Figure 15. Reset Timings

**Table 38. Erase and Program Operations-S29GL064A**

Parameter		Description		Speed Options			Unit
JEDEC	Std.			90	10	11	
$t_{AVAV}$	$t_{WC}$	Write Cycle Time (Note 1)	Min	90	100	110	ns
$t_{AVWL}$	$t_{AS}$	Address Setup Time	Min	0			ns
	$t_{ASO}$	Address Setup Time to OE# low during toggle bit polling	Min	15			ns
$t_{WLAX}$	$t_{AH}$	Address Hold Time	Min	45			ns
	$t_{AHT}$	Address Hold Time From CE# or OE# high during toggle bit polling	Min	0			ns
$t_{DVWH}$	$t_{DS}$	Data Setup Time	Min	35			ns
$t_{WHDX}$	$t_{DH}$	Data Hold Time	Min	0			ns
	$t_{CEPH}$	CE# High during toggle bit polling	Min	20			ns
	$t_{OEPH}$	OE# High during toggle bit polling	Min	20			ns
$t_{GHWL}$	$t_{GHWL}$	Read Recovery Time Before Write (OE# High to WE# Low)	Min	0			ns
$t_{ELWL}$	$t_{CS}$	CE# Setup Time	Min	0			ns
$t_{WHEH}$	$t_{CH}$	CE# Hold Time	Min	0			ns
$t_{WLWH}$	$t_{WP}$	Write Pulse Width	Min	35			ns
$t_{WHDL}$	$t_{WPH}$	Write Pulse Width High	Min	30			ns
$t_{WHWH1}$	$t_{WHWH1}$	Write Buffer Program Operation (Note 2, Note 3)	Typ	240			$\mu$ s
		Single Word Program Operation (Note 2)	Typ	60			
		Accelerated Single Word Program Operation (Note 2)	Typ	54			
$t_{WHWH2}$	$t_{WHWH2}$	Sector Erase Operation (Note 2)	Typ	0.5			sec
	$t_{VHH}$	$V_{HH}$ Rise and Fall Time (Note 1)	Min	250			ns
	$t_{VCS}$	$V_{CC}$ Setup Time (Note 1)	Min	50			$\mu$ s
	$t_{BUSY}$	WE# High to RY/BY# Low	Min	90	100	110	ns
	$t_{POLL}$	Program Valid before Status Polling	Max	4			$\mu$ s

**Notes:**

1. Not 100% tested.
2. See the [Erase And Programming Performance](#) on page 87 for more information.
3. For 1–16 words/1–32 bytes programmed.
4. If a program suspend command is issued within  $t_{POLL}$ , the device requires  $t_{POLL}$  before reading status data, once programming resumes (that is, the program resume command is written). If the suspend command was issued after  $t_{POLL}$ , status data is available immediately after programming resumes. See [Figure 16](#), on page 79.

Table 39. Erase and Program Operations-S29GL032A Only

Parameter		Description		Speed Options			Unit
JEDEC	Std.			90	10	11	
$t_{AVAV}$	$t_{WC}$	Write Cycle Time (Note 1)	Min	90	100	110	ns
$t_{AVWL}$	$t_{AS}$	Address Setup Time	Min	0			ns
	$t_{ASO}$	Address Setup Time to OE# low during toggle bit polling	Min	15			ns
$t_{WLAX}$	$t_{AH}$	Address Hold Time	Min	45			ns
	$t_{AHT}$	Address Hold Time From CE# or OE# high during toggle bit polling	Min	0			ns
$t_{DVWH}$	$t_{DS}$	Data Setup Time	Min	35			ns
$t_{WHDX}$	$t_{DH}$	Data Hold Time	Min	0			ns
	$t_{CEPH}$	CE# High during toggle bit polling	Min	20			ns
	$t_{OEPH}$	OE# High during toggle bit polling	Min	20			ns
$t_{GHWL}$	$t_{GHWL}$	Read Recovery Time Before Write (OE# High to WE# Low)	Min	0			ns
$t_{ELWL}$	$t_{CS}$	CE# Setup Time	Min	0			ns
$t_{WHEH}$	$t_{CH}$	CE# Hold Time	Min	0			ns
$t_{WLWH}$	$t_{WP}$	Write Pulse Width	Min	35			ns
$t_{WHDL}$	$t_{WPH}$	Write Pulse Width High	Min	30			ns
$t_{WHWH1}$	$t_{WHWH1}$	Write Buffer Program Operation (Note 2, Note 3)	Typ	240			$\mu$ s
		Single Word Program Operation (Note 2)	Typ	60			
		Accelerated Single Word Program Operation (Note 2)	Typ	54			
$t_{WHWH2}$	$t_{WHWH2}$	Sector Erase Operation (Note 2)	Typ	0.5			sec
	$t_{VHH}$	$V_{HH}$ Rise and Fall Time (Note 1)	Min	250			ns
	$t_{VCS}$	$V_{CC}$ Setup Time (Note 1)	Min	50			$\mu$ s
	$t_{BUSY}$	WE# High to RY/BY# Low	Min	90	100	110	ns
	$t_{POLL}$	Program Valid before Status Polling	Max	4			$\mu$ s

**Notes:**

- Not 100% tested.
- See [Erase And Programming Performance on page 87](#) for more information
- For 1–16 words/1–32 bytes programmed.
- Effective write buffer specification is based upon a 16-word/32-byte write buffer operation.
- If a program suspend command is issued within  $t_{POLL}$ , the device requires  $t_{POLL}$  before reading status data, once programming resumes (that is, the program resume command is written). If the suspend command was issued after  $t_{POLL}$ , status data is available immediately after programming resumes. See [Figure 16, on page 79](#).

**Table 40. Erase and Program Operations-S29GL016A Only**

Parameter		Description		Speed Options		Unit
JEDEC	Std.			90	10	
$t_{AVAV}$	$t_{WC}$	Write Cycle Time (Note 1)	Min	90	100	ns
$t_{AVWL}$	$t_{AS}$	Address Setup Time	Min	0		ns
	$t_{ASO}$	Address Setup Time to OE# low during toggle bit polling	Min	15		ns
$t_{WLAX}$	$t_{AH}$	Address Hold Time	Min	45		ns
	$t_{AHT}$	Address Hold Time From CE# or OE# high during toggle bit polling	Min	0		ns
$t_{DVWH}$	$t_{DS}$	Data Setup Time	Min	35		ns
$t_{WHDX}$	$t_{DH}$	Data Hold Time	Min	0		ns
	$t_{CEPH}$	CE# High during toggle bit polling	Min	20		ns
	$t_{OEPH}$	OE# High during toggle bit polling	Min	20		ns
$t_{GHWL}$	$t_{GHWL}$	Read Recovery Time Before Write (OE# High to WE# Low)	Min	0		ns
$t_{ELWL}$	$t_{CS}$	CE# Setup Time	Min	0		ns
$t_{WHEH}$	$t_{CH}$	CE# Hold Time	Min	0		ns
$t_{WLWH}$	$t_{WP}$	Write Pulse Width	Min	35		ns
$t_{WHDL}$	$t_{WPH}$	Write Pulse Width High	Min	30		ns
$t_{WHWH1}$	$t_{WHWH1}$	Write Buffer Program Operation (Note 2, Note 3)	Typ	240		$\mu$ s
		Single Word Program Operation (Note 2)	Typ	60		
		Accelerated Single Word Program Operation (Note 2)	Typ	54		
$t_{WHWH2}$	$t_{WHWH2}$	Sector Erase Operation (Note 2)	Typ	0.5		sec
	$t_{VHH}$	$V_{HH}$ Rise and Fall Time (Note 1)	Min	250		ns
	$t_{VCS}$	$V_{CC}$ Setup Time (Note 1)	Min	50		$\mu$ s
	$t_{BUSY}$	WE# High to RY/BY# Low	Min	90	100	ns
	$t_{POLL}$	Program Valid before Status Polling	Max	4		$\mu$ s

**Notes:**

1. Not 100% tested.
2. See [Erase And Programming Performance on page 87](#) for more information
3. For 1–16 words/1–32 bytes programmed.
4. Effective write buffer specification is based upon a 16-word/32-byte write buffer operation.
5. If a program suspend command is issued within  $t_{POLL}$ , the device requires  $t_{POLL}$  before reading status data, once programming resumes (that is, the program resume command is written). If the suspend command was issued after  $t_{POLL}$ , status data is available immediately after programming resumes. See [Figure 16, on page 79](#)



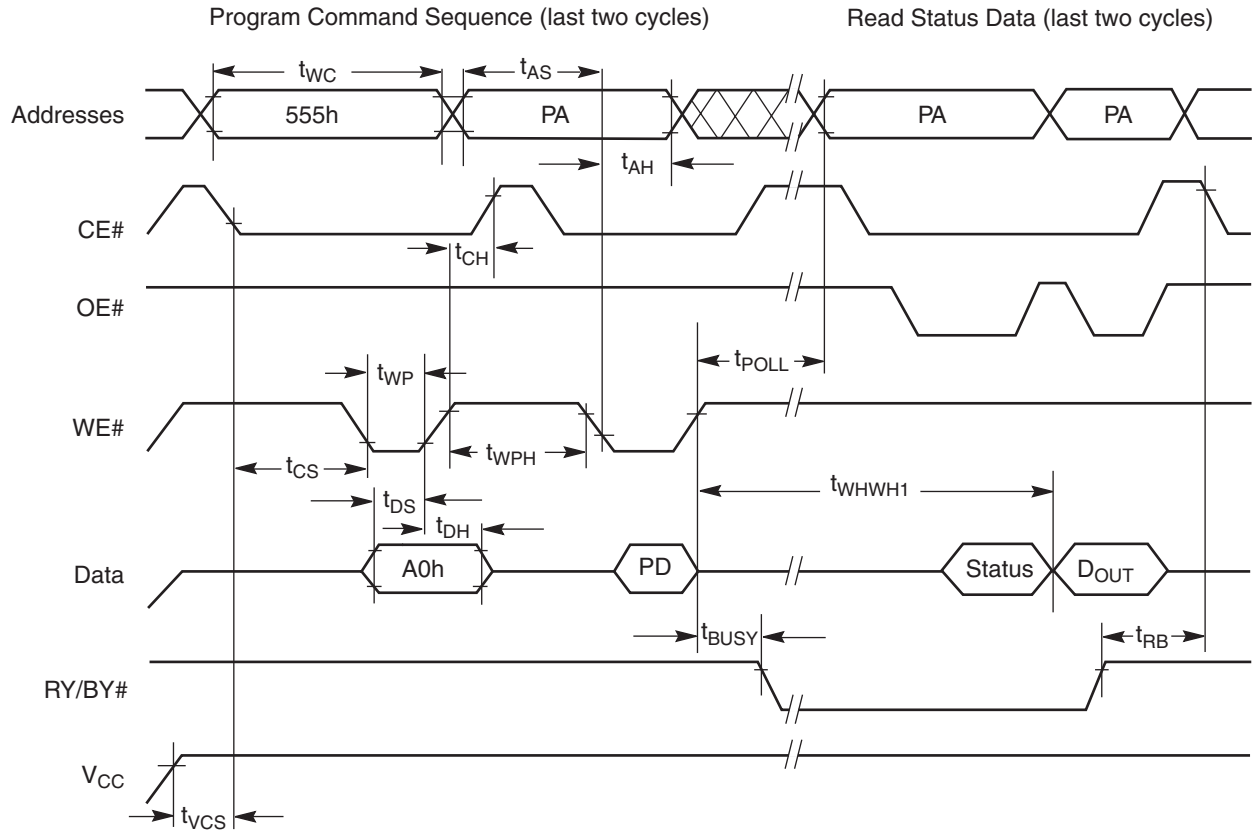

**Notes:**

1. PA = program address, PD = program data, D<sub>OUT</sub> is the true data at the program address.
2. Illustration shows device in word mode.

**Figure I6. Program Operation Timings**

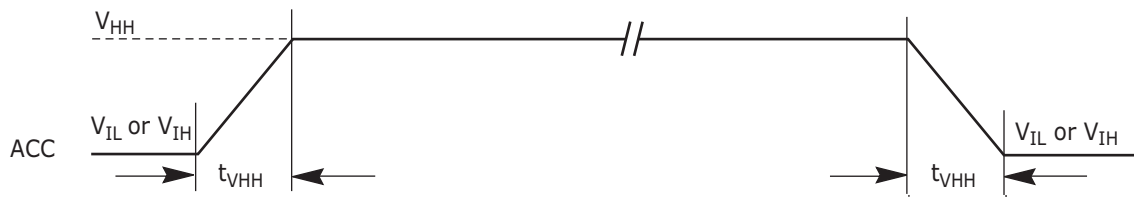

**Figure I7. Accelerated Program Timing Diagram**

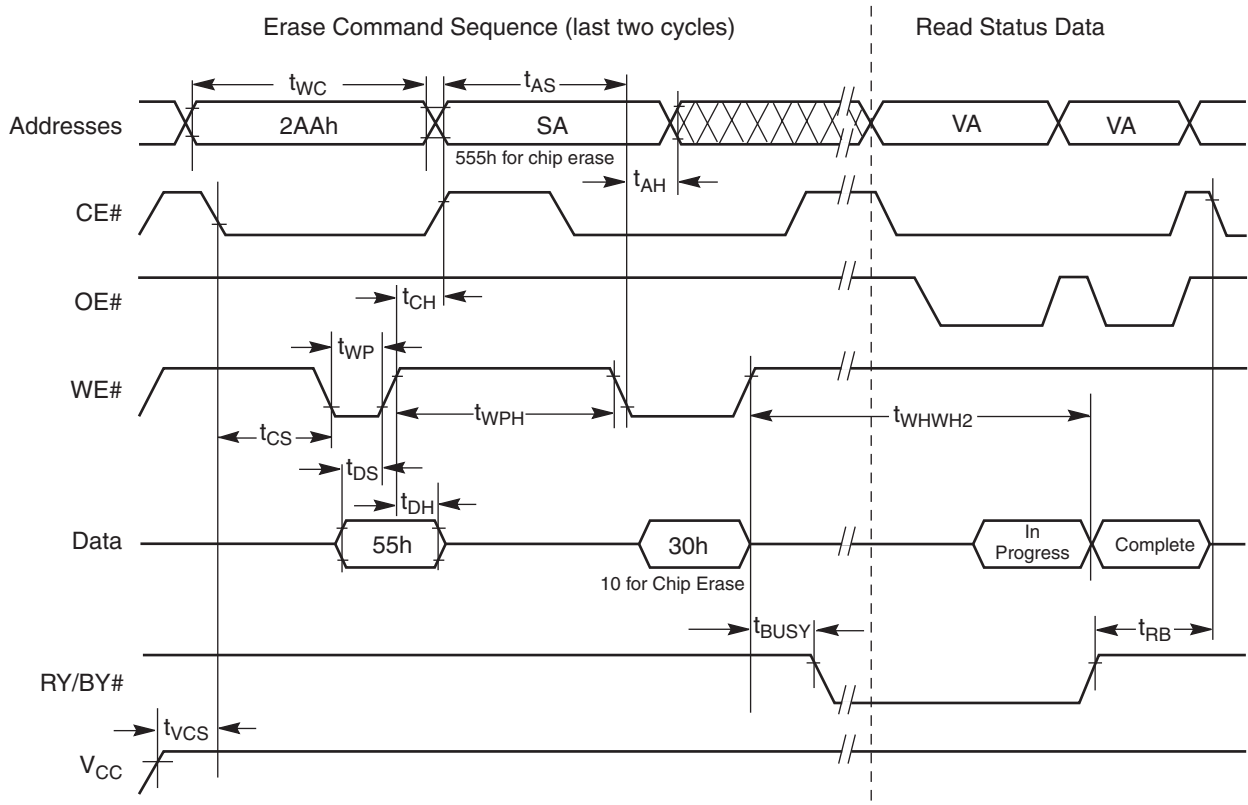

**Notes:**

1. SA = sector address (for Sector Erase), VA = Valid Address for reading status data (see [Write Operation Status on page 63.](#))
2. Illustration shows device in word mode.

**Figure 18. Chip/Sector Erase Operation Timings**

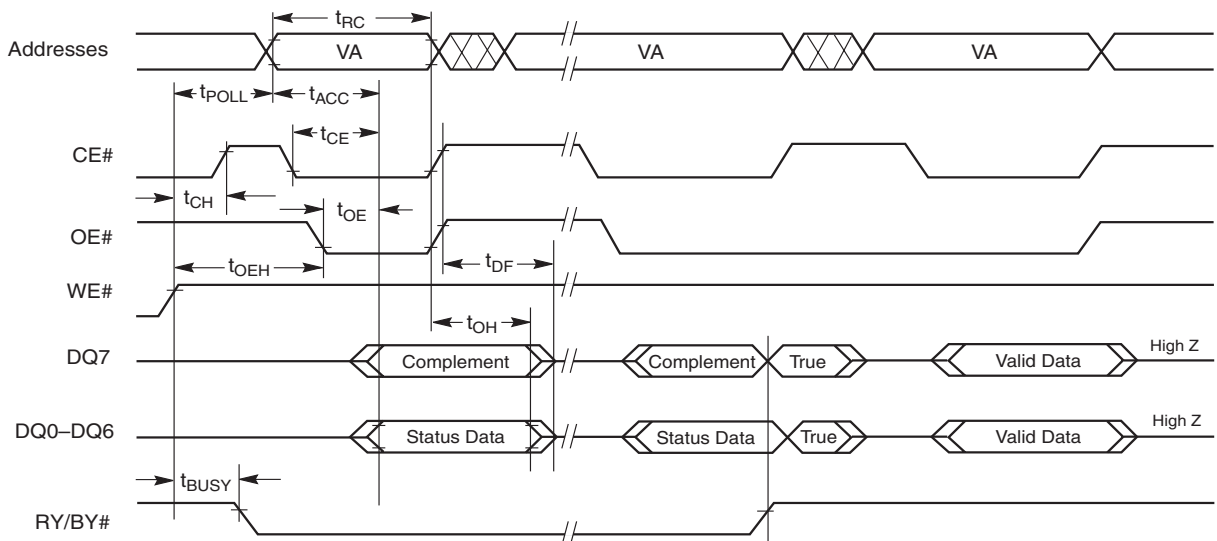

**Note:** VA = Valid address. Illustration shows first status cycle after command sequence, last status read cycle, and array data read cycle.

**Figure 19. Data# Polling Timings (During Embedded Algorithms)**

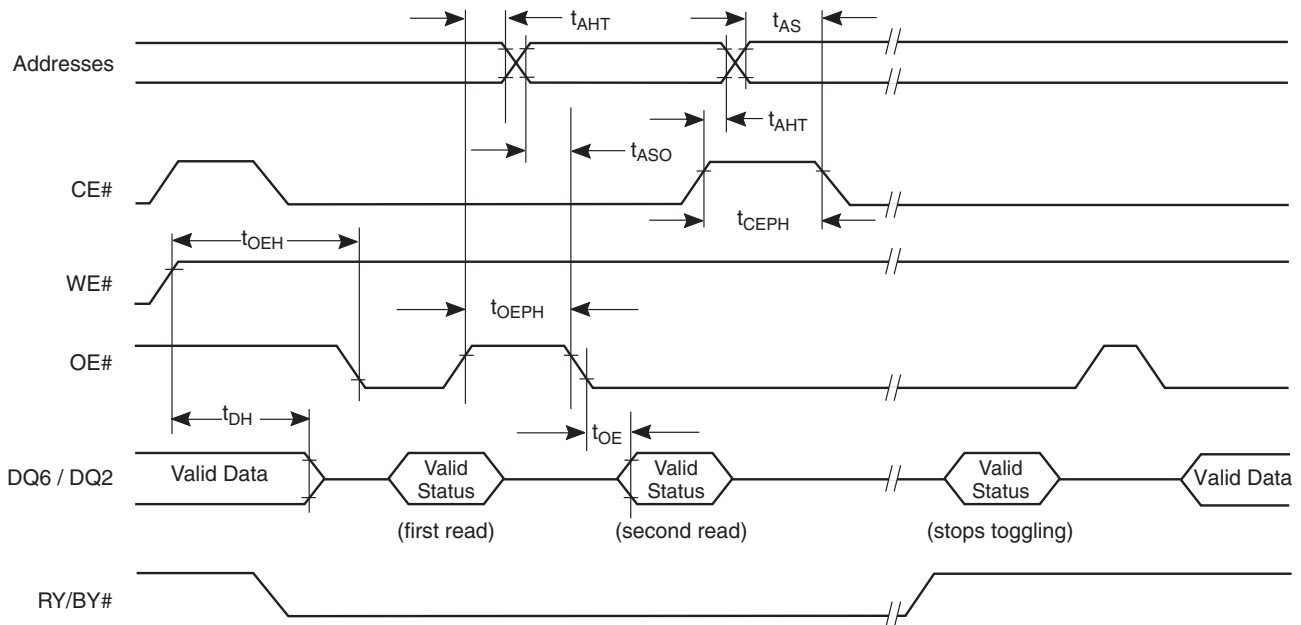

**Note:** VA = Valid address; not required for DQ6. Illustration shows first two status cycle after command sequence, last status read cycle, and array data read cycle.

**Figure 20. Toggle Bit Timings (During Embedded Algorithms)**

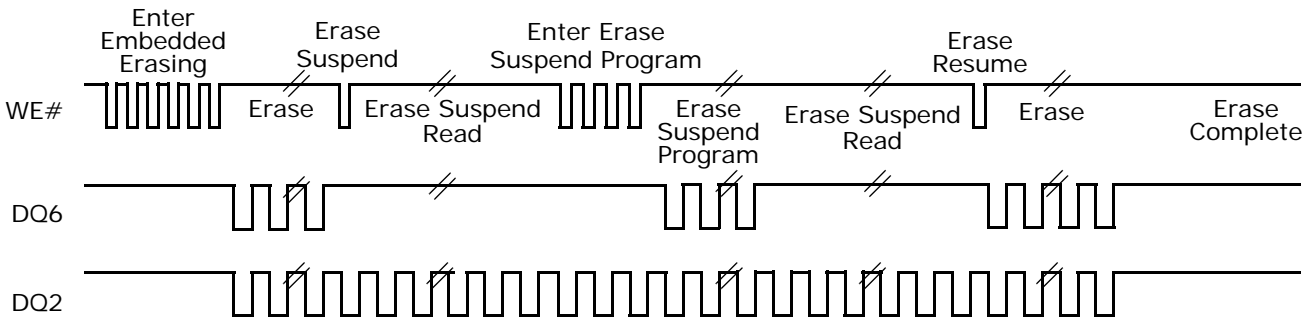

**Note:** DQ2 toggles only when read at an address within an erase-suspended sector. The system may use OE# or CE# to toggle DQ2 and DQ6.

**Figure 21. DQ2 vs. DQ6**

**Table 4I. Temporary Sector Unprotect**

Parameter		Description		All Speed Options	Unit
JEDEC	Std				
	t <sub>VIDR</sub>	V <sub>ID</sub> Rise and Fall Time (See Note)	Min	500	ns
	t <sub>RSP</sub>	RESET# Setup Time for Temporary Sector Unprotect	Min	4	µs

**Note:** Not 100% tested.

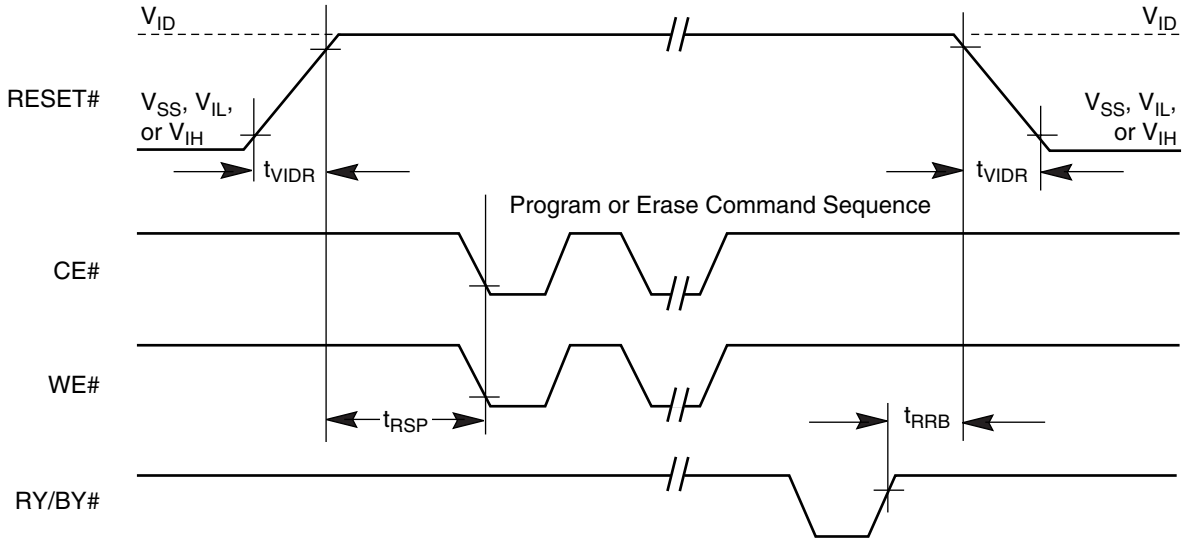
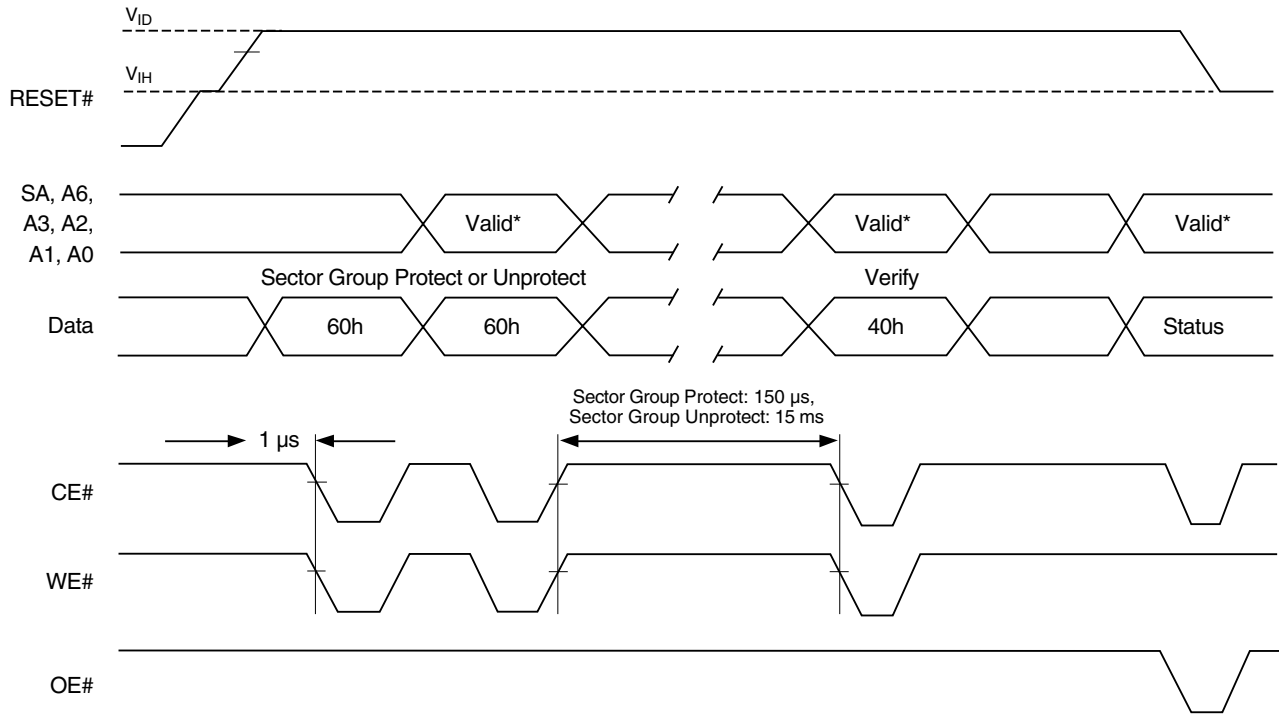

Figure 22. Temporary Sector Group Unprotect Timing Diagram



**Note:** For sector group protect, A6:A0 = 0xx0010. For sector group unprotect, A6:A0 = 1xx0010.

Figure 23. Sector Group Protect and Unprotect Timing Diagram

**Table 42. Alternate CE# Controlled Erase and Program Operations-S29GL064A**

Parameter		Description		Speed Options			Unit
JEDEC	Std.			90	10	11	
$t_{AVAV}$	$t_{WC}$	Write Cycle Time (Note 1)	Min	90	100	110	ns
$t_{AVWL}$	$t_{AS}$	Address Setup Time	Min	0			ns
$t_{ELAX}$	$t_{AH}$	Address Hold Time	Min	45			ns
$t_{DVEH}$	$t_{DS}$	Data Setup Time	Min	35			ns
$t_{EHDX}$	$t_{DH}$	Data Hold Time	Min	0			ns
$t_{GHEL}$	$t_{GHEL}$	Read Recovery Time Before Write (OE# High to WE# Low)	Min	0			ns
$t_{WLEL}$	$t_{WS}$	WE# Setup Time	Min	0			ns
$t_{EHWH}$	$t_{WH}$	WE# Hold Time	Min	0			ns
$t_{ELEH}$	$t_{CP}$	CE# Pulse Width	Min	35			ns
$t_{EHEL}$	$t_{CPH}$	CE# Pulse Width High	Min	25			ns
$t_{WHWH1}$	$t_{WHWH1}$	Write Buffer Program Operation (Notes 2, 3)	Typ	240			$\mu$ s
		Single Word Program Operation (Note 2)	Typ	60			
		Accelerated Single Word Program Operation (Note 2)	Typ	54			
$t_{WHWH2}$	$t_{WHWH2}$	Sector Erase Operation (Note 2)	Typ	0.5			sec
	$t_{RH}$	RESET# High Time Before Write	Min	50			ns
	$t_{POLL}$	Program Valid before Status Polling (Note 4)	Max	4			$\mu$ s

**Notes:**

1. Not 100% tested.
2. See the [Erase And Programming Performance](#) on page 87 for more information.
3. For 1–16 words/1–32 bytes programmed.
4. If a program suspend command is issued within  $t_{POLL}$ , the device requires  $t_{POLL}$  before reading status data, once programming resumes (that is, the program resume command is written). If the suspend command was issued after  $t_{POLL}$ , status data is available immediately after programming resumes. See [Figure 24](#), on page 86.

**Table 43. Alternate CE# Controlled Erase and Program Operations-S29GL032A**

Parameter		Description		Speed Options			Unit
JEDEC	Std.			90	10	11	
$t_{AVAV}$	$t_{WC}$	Write Cycle Time (Note 1)	Min	90	100	110	ns
$t_{AVWL}$	$t_{AS}$	Address Setup Time	Min	0			ns
$t_{ELAX}$	$t_{AH}$	Address Hold Time	Min	45			ns
$t_{DVEH}$	$t_{DS}$	Data Setup Time	Min	35			ns
$t_{EHDX}$	$t_{DH}$	Data Hold Time	Min	0			ns
$t_{GHLEL}$	$t_{GHLEL}$	Read Recovery Time Before Write (OE# High to WE# Low)	Min	0			ns
$t_{WLEL}$	$t_{WS}$	WE# Setup Time	Min	0			ns
$t_{EHWH}$	$t_{WH}$	WE# Hold Time	Min	0			ns
$t_{ELEH}$	$t_{CP}$	CE# Pulse Width	Min	35			ns
$t_{EHEL}$	$t_{CPH}$	CE# Pulse Width High	Min	25			ns
$t_{WHWH1}$	$t_{WHWH1}$	Write Buffer Program Operation (Notes 2, 3)	Typ	240			$\mu$ s
		Single Word Program Operation (Note 2)	Typ	60			
		Accelerated Single Word Program Operation (Note 2)	Typ	54			
$t_{WHWH2}$	$t_{WHWH2}$	Sector Erase Operation (Note 2)	Typ	0.5			sec
	$t_{RH}$	RESET# High Time Before Write	Min	50			ns
	$t_{POLL}$	Program Valid before Status Polling (Note 4)	Max	4			$\mu$ s

**Notes:**

1. Not 100% tested.
2. See [Erase And Programming Performance on page 87](#) for more information
3. For 1–16 words/1–32 bytes programmed.
4. If a program suspend command is issued within  $t_{POLL}$ , the device requires  $t_{POLL}$  before reading status data, once programming resumes (that is, the program resume command is written). If the suspend command was issued after  $t_{POLL}$ , status data is available immediately after programming resumes. See [Figure 24, on page 86](#).

Table 44. Alternate CE# Controlled Erase and Program Operations-S29GL016A

Parameter		Description		Speed Options		Unit
JEDEC	Std.			90	10	
$t_{AVAV}$	$t_{WC}$	Write Cycle Time (Note 1)	Min	90	100	ns
$t_{AVWL}$	$t_{AS}$	Address Setup Time	Min	0		ns
$t_{ELAX}$	$t_{AH}$	Address Hold Time	Min	45		ns
$t_{DVEH}$	$t_{DS}$	Data Setup Time	Min	35		ns
$t_{EHDX}$	$t_{DH}$	Data Hold Time	Min	0		ns
$t_{GHLEL}$	$t_{GHLEL}$	Read Recovery Time Before Write (OE# High to WE# Low)	Min	0		ns
$t_{WLEL}$	$t_{WS}$	WE# Setup Time	Min	0		ns
$t_{EHWH}$	$t_{WH}$	WE# Hold Time	Min	0		ns
$t_{ELEH}$	$t_{CP}$	CE# Pulse Width	Min	35		ns
$t_{EHEL}$	$t_{CPH}$	CE# Pulse Width High	Min	25		ns
$t_{WHWH1}$	$t_{WHWH1}$	Write Buffer Program Operation (Note 2, Note 3)	Typ	240		$\mu$ s
		Single Word Program Operation (Note 2)	Typ	60		
		Accelerated Single Word Program Operation (Note 2)	Typ	54		
$t_{WHWH2}$	$t_{WHWH2}$	Sector Erase Operation (Note 2)	Typ	0.5		sec
	$t_{RH}$	RESET# High Time Before Write	Min	50		ns
	$t_{POLL}$	Program Valid before Status Polling (Note 4)	Max	4		$\mu$ s

**Notes:**

1. Not 100% tested.
2. See [Erase And Programming Performance on page 87](#) for more information
3. For 1–16 words/1–32 bytes programmed.
4. If a program suspend command is issued within  $t_{POLL}$ , the device requires  $t_{POLL}$  before reading status data, once programming resumes (that is, the program resume command is written). If the suspend command was issued after  $t_{POLL}$ , status data is available immediately after programming resumes. See [Figure 24, on page 86](#)

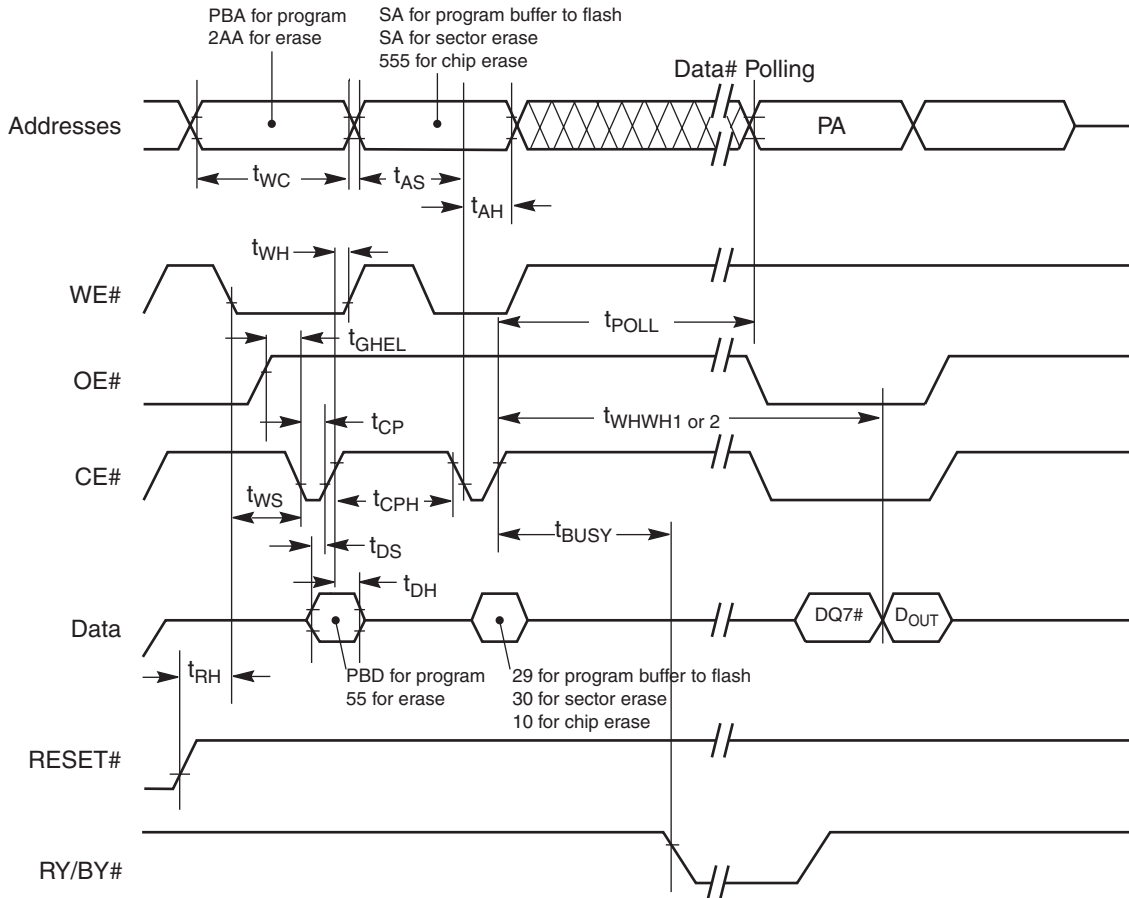

**Notes:**

1. Figure indicates last two bus cycles of a program or erase operation.
2. PA = program address, SA = sector address, PD = program data.
3. DQ7# is the complement of the data written to the device. D<sub>OUT</sub> is the data written to the device.
4. Illustration shows device in word mode

**Figure 24. Alternate CE# Controlled Write (Erase/Program) Operation Timings**



## Erase And Programming Performance

Parameter		Typ (Note 1)	Max (Note 2)	Unit	Comments
Sector Erase Time		0.5	3.5	sec	Excludes 00h programming prior to erasure (Note 6)
Chip Erase Time	S29GL016A	17.5	35		
	S29GL032A	32	64		
	S29GL064A	64	128		
Total Write Buffer Program Time (Notes 3, 5)		240		μs	Excludes system level overhead (Note 7)
Total Accelerated Effective Write Buffer Program Time (Notes 4, 5)		200			
Chip Program Time	S29GL016A	16		sec	
	S29GL032A	31.5			
	S29GL064A	63			

### Notes:

1. Typical program and erase times assume the following conditions: 25°C,  $V_{CC} = 3.0V$ , 10,000 cycles; checkerboard data pattern.
2. Under worst case conditions of 90°C; Worst case  $V_{CC}$ , 100,000 cycles.
3. Effective programming time (typ) is 15 μs (per word), 7.5 μs (per byte).
4. Effective accelerated programming time (typ) is 12.5 μs (per word), 6.3 μs (per byte).
5. Effective write buffer specification is calculated on a per-word/per-byte basis for a 16-word/32-byte write buffer operation.
6. In the pre-programming step of the Embedded Erase algorithm, all bits are programmed to 00h before erasure.
7. System-level overhead is the time required to execute the command sequence(s) for the program command. See Table 30 on page 61 and Table 31 on page 62 for further information on command definitions.

**Table 45. TSOP Pin and BGA Package Capacitance**

Parameter Symbol	Parameter Description	Test Setup	Typ	Max	Unit	
$C_{IN}$	Input Capacitance	$V_{IN} = 0$	TSOP	6	7.5	pF
			BGA	4.2	5.0	pF
$C_{OUT}$	Output Capacitance	$V_{OUT} = 0$	TSOP	8.5	12	pF
			BGA	5.4	6.5	pF
$C_{IN2}$	Control Pin Capacitance	$V_{IN} = 0$	TSOP	7.5	9	pF
			BGA	3.9	4.7	pF

### Notes:

1. Sampled, not 100% tested.
2. Test conditions  $T_A = 25^\circ C$ ,  $f = 1.0$  MHz.

# Physical Dimensions

## TS048—48-Pin Standard Thin Small Outline Package (TSOP)

### STANDARD PIN OUT (TOP VIEW)

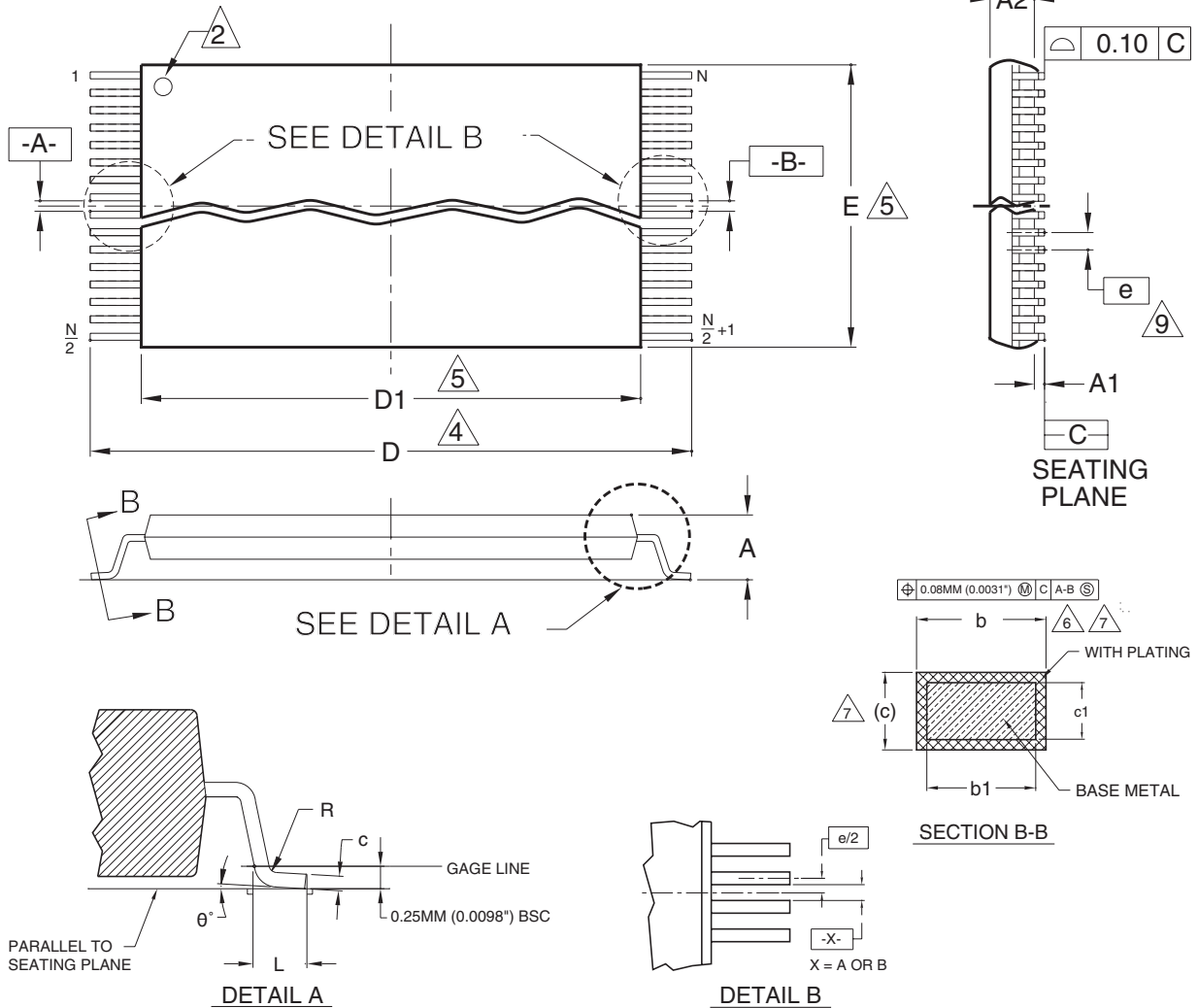

Package	TS 048		
Jedec	MO-142 (B) EC		
Symbol	MIN	NOM	MAX
A	—	—	1.20
A1	0.05	—	0.15
A2	0.95	1.00	1.05
b1	0.17	0.20	0.23
b	0.17	0.22	0.27
c1	0.10	—	0.16
c	0.10	—	0.21
D	19.80	20.00	20.20
D1	18.30	18.40	18.50
E	11.90	12.00	12.10
e	0.50 BASIC		
L	0.50	0.60	0.70
0	0°	3°	5°
R	0.08	—	0.20
N	48		

NOTES:

- ① CONTROLLING DIMENSIONS ARE IN MILLIMETERS (MM). (DIMENSIONING AND TOLERANCING CONFORMS TO ANSI Y14.5M-1982)
- ② PIN 1 IDENTIFIER FOR STANDARD PIN OUT (DIE UP).
- ③ NOT APPLICABLE.
- ④ TO BE DETERMINED AT THE SEATING PLANE [C-C]. THE SEATING PLANE IS DEFINED AS THE PLANE OF CONTACT THAT IS MADE WHEN THE PACKAGE LEADS ARE ALLOWED TO REST FREELY ON A FLAT HORIZONTAL SURFACE.
- ⑤ DIMENSIONS D1 AND E DO NOT INCLUDE MOLD PROTRUSION. ALLOWABLE MOLD PROTRUSION IS 0.15MM (.0059") PER SIDE.
- ⑥ DIMENSION b DOES NOT INCLUDE DAMBAR PROTRUSION. ALLOWABLE DAMBAR PROTRUSION SHALL BE 0.08 (0.0031") TOTAL IN EXCESS OF b DIMENSION AT MAX. MATERIAL CONDITION. MINIMUM SPACE BETWEEN PROTRUSION AND AN ADJACENT LEAD TO BE 0.07 (0.0028").
- ⑦ THESE DIMENSIONS APPLY TO THE FLAT SECTION OF THE LEAD BETWEEN 0.10MM (.0039") AND 0.25MM (0.0098") FROM THE LEAD TIP.
- ⑧ LEAD COPLANARITY SHALL BE WITHIN 0.10MM (0.004") AS MEASURED FROM THE SEATING PLANE.
- ⑨ DIMENSION "e" IS MEASURED AT THE CENTERLINE OF THE LEADS.

3325 \ 16-038.10a

## TS056—56-Pin Standard Thin Small Outline Package (TSOP)

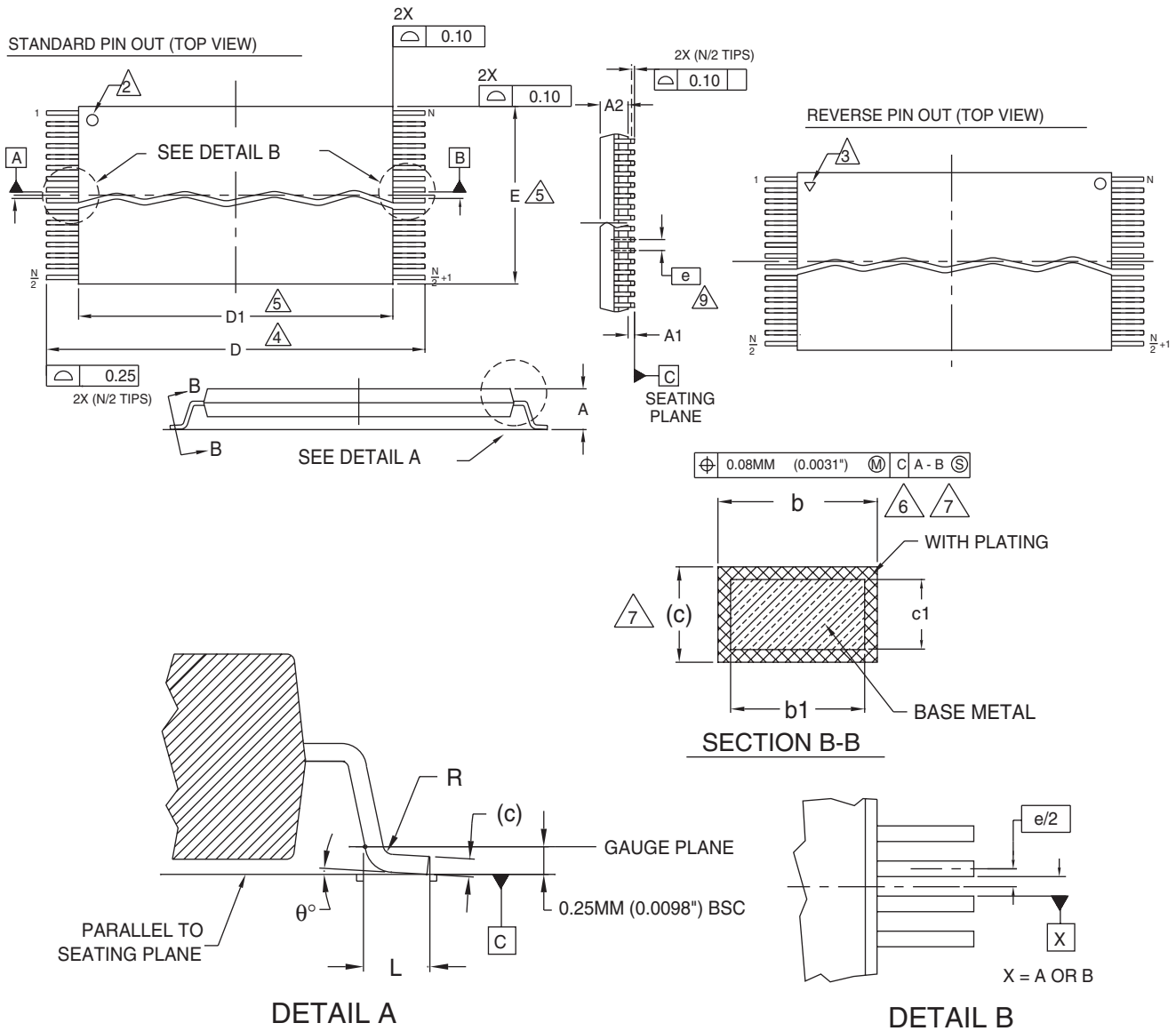

Package	TS 056		
Jedec	MO-142 (D) EC		
Symbol	MIN	NOM	MAX
A	—	—	1.20
A1	0.05	—	0.15
A2	0.95	1.00	1.05
b1	0.17	0.20	0.23
b	0.17	0.22	0.27
c1	0.10	—	0.16
c	0.10	—	0.21
D	19.80	20.00	20.20
D1	18.30	18.40	18.50
E	13.90	14.00	14.10
e	0.50 BASIC		
L	0.50	0.60	0.70
θ	0°	—	8°
R	0.08	—	0.20
N	56		

**NOTES:**

- ① CONTROLLING DIMENSIONS ARE IN MILLIMETERS (mm). (DIMENSIONING AND TOLERANCING CONFORMS TO ANSI Y14.5M-1982)
- ② PIN 1 IDENTIFIER FOR REVERSE PIN OUT (DIE UP).
- ③ PIN 1 IDENTIFIER FOR REVERSE PIN OUT (DIE DOWN), INK OR LASER MARK.
- ④ TO BE DETERMINED AT THE SEATING PLANE [C-C]. THE SEATING PLANE IS DEFINED AS THE PLANE OF CONTACT THAT IS MADE WHEN THE PACKAGE LEADS ARE ALLOWED TO REST FREELY ON A FLAT HORIZONTAL SURFACE.
- ⑤ DIMENSIONS D1 AND E DO NOT INCLUDE MOLD PROTRUSION. ALLOWABLE MOLD PROTRUSION IS 0.15mm (.0059") PER SIDE.
- ⑥ DIMENSION b DOES NOT INCLUDE DAMBAR PROTRUSION. ALLOWABLE DAMBAR PROTRUSION SHALL BE 0.08 (0.0031") TOTAL IN EXCESS OF b DIMENSION AT MAX. MATERIAL CONDITION. MINIMUM SPACE BETWEEN PROTRUSION AND AN ADJACENT LEAD TO BE 0.07 (0.0028").
- ⑦ THESE DIMENSIONS APPLY TO THE FLAT SECTION OF THE LEAD BETWEEN 0.10MM (.0039") AND 0.25MM (0.0098") FROM THE LEAD TIP.
- ⑧ LEAD COPLANARITY SHALL BE WITHIN 0.10mm (0.004") AS MEASURED FROM THE SEATING PLANE.
- ⑨ DIMENSION "e" IS MEASURED AT THE CENTERLINE OF THE LEADS.

3356 \ 16-038.10c

# LAA064—64-Ball Fortified Ball Grid Array (BGA)

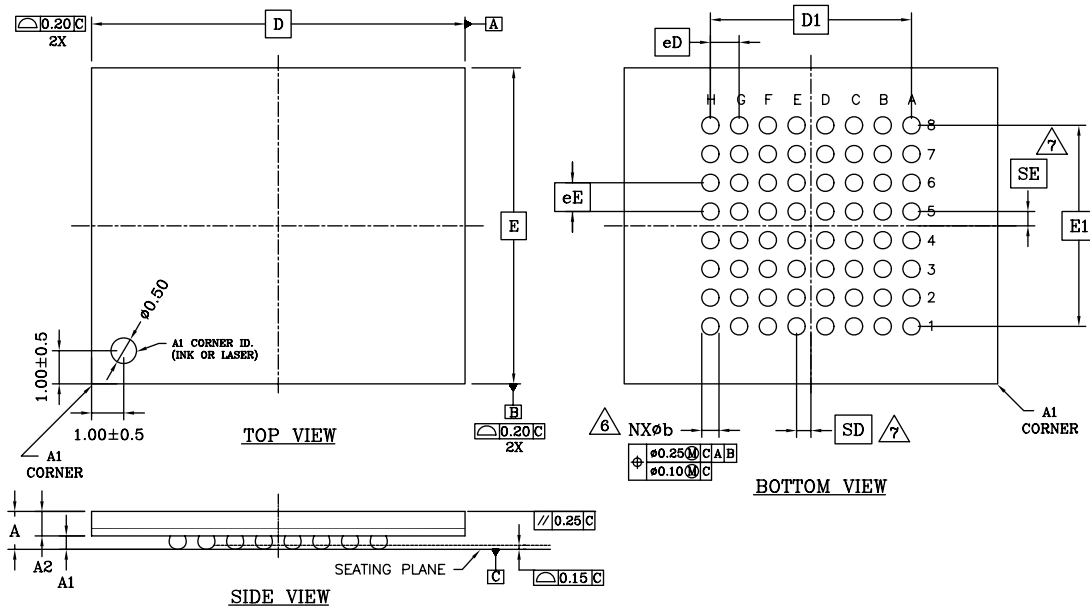

PACKAGE	LAA 064			
JEDEC	N/A			
	13.00x11.00 mm PACKAGE			
SYMBOL	MIN.	NOM.	MAX.	NOTE
A	—	—	1.40	PROFILE HEIGHT
A1	0.40	—	—	STANDOFF
A2	0.60	—	—	BODY THICKNESS
D	13.00 BSC.			BODY SIZE
E	11.00 BSC.			BODY SIZE
D1	7.00 BSC.			MATRIX FOOTPRINT
E1	7.00 BSC.			MATRIX FOOTPRINT
MD	8			MATRIX SIZE D DIRECTION
ME	8			MATRIX SIZE E DIRECTION
N	64			BALL COUNT
phi b	0.50	0.60	0.70	BALL DIAMETER
eD	1.00 BSC.			BALL PITCH - D DIRECTION
eE	1.00 BSC.			BALL PITCH - E DIRECTION
SD/SE	0.50 BSC.			SOLDER BALL PLACEMENT
	A1-AB, K1-KB			DEPOPULATED SOLDER BALLS

**NOTES:**

- DIMENSIONING AND TOLERANCING METHODS PER ASME Y14.5M-1994 .
- ALL DIMENSIONS ARE IN MILLIMETERS .
- BALL POSITION DESIGNATION PER JESD 95-1, SPP-010 (EXCEPT AS NOTED).
- [C] REPRESENTS THE SOLDER BALL GRID PITCH .
- SYMBOL "MD" IS THE BALL MATRIX SIZE IN THE "D" DIRECTION.  
SYMBOL "ME" IS THE BALL COLUMN MATRIX SIZE IN THE "E" DIRECTION.  
N IS THE NUMBER OF POPULATED SOLDER BALL POSITIONS FOR MATRIX SIZE MD X ME.
- [6] DIMENSION "b" IS MEASURED AT THE MAXIMUM BALL DIAMETER IN A PLANE PARALLEL TO DATUM "C".
- [7] SD AND SE ARE MEASURED WITH RESPECT TO DATUMS A AND B AND DEFINE THE POSITION OF THE CENTER SOLDER BALL IN THE OUTER ROW.  
WHEN THERE IS AN ODD NUMBER OF SOLDER BALLS IN THE OUTER ROW, SD OR SE = 0.000.  
WHEN THERE IS AN EVEN NUMBER OF SOLDER BALLS IN THE OUTER ROW, SD OR SE =  $\frac{e}{2}$
- "X" IN THE PACKAGE VARIATIONS DENOTES PART IS UNDER QUALIFICATION.
- "+" INDICATES THE THEORETICAL CENTER OF DEPOPULATED BALLS.

# VBN048—48-Ball Fine-pitch Ball Grid Array (BGA) 10x 6 mm Package

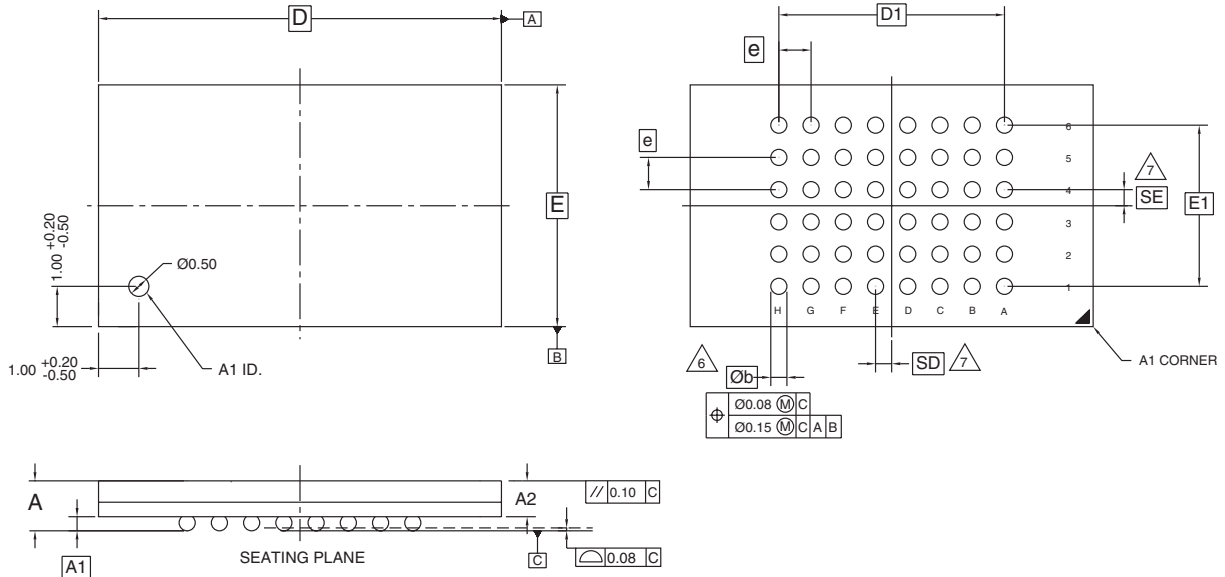

PACKAGE	VBN 048			
JEDEC	N/A			
	10.00 mm x 6.00 mm NOM PACKAGE			
SYMBOL	MIN	NOM	MAX	NOTE
A	---	---	1.00	OVERALL THICKNESS
A1	0.17	---	---	BALL HEIGHT
A2	0.62	---	0.73	BODY THICKNESS
D	10.00 BSC.			BODY SIZE
E	6.00 BSC.			BODY SIZE
D1	5.60 BSC.			BALL FOOTPRINT
E1	4.00 BSC.			BALL FOOTPRINT
MD	8			ROW MATRIX SIZE D DIRECTION
ME	6			ROW MATRIX SIZE E DIRECTION
N	48			TOTAL BALL COUNT
φb	0.35	---	0.45	BALL DIAMETER
e	0.80 BSC.			BALL PITCH
SD / SE	0.40 BSC.			SOLDER BALL PLACEMENT
	NONE			DEPOPULATED SOLDER BALLS

NOTES:

- DIMENSIONING AND TOLERANCING PER ASME Y14.5M-1994.
- ALL DIMENSIONS ARE IN MILLIMETERS.
- BALL POSITION DESIGNATION PER JESD 95-1, SPP-010 (EXCEPT AS NOTED).
- e** REPRESENTS THE SOLDER BALL GRID PITCH.
- SYMBOL "MD" IS THE BALL ROW MATRIX SIZE IN THE "D" DIRECTION.  
SYMBOL "ME" IS THE BALL COLUMN MATRIX SIZE IN THE "E" DIRECTION.  
N IS THE TOTAL NUMBER OF SOLDER BALLS.
- 6** DIMENSION "b" IS MEASURED AT THE MAXIMUM BALL DIAMETER IN A PLANE PARALLEL TO DATUM C.
- 7** SD AND SE ARE MEASURED WITH RESPECT TO DATUMS A AND B AND DEFINE THE POSITION OF THE CENTER SOLDER BALL IN THE OUTER ROW.  
WHEN THERE IS AN ODD NUMBER OF SOLDER BALLS IN THE OUTER ROW PARALLEL TO THE D OR E DIMENSION, RESPECTIVELY, SD OR SE = 0.000.  
WHEN THERE IS AN EVEN NUMBER OF SOLDER BALLS IN THE OUTER ROW, SD OR SE =  $\frac{e}{2}$
- NOT USED.
- "+" INDICATES THE THEORETICAL CENTER OF DEPOPULATED BALLS.
- 10** A1 CORNER TO BE IDENTIFIED BY CHAMFER, LASER OR INK MARK, METALLIZED MARK INDENTATION OR OTHER MEANS.

34251 16-038.25

# VBK048—Ball Fine-pitch Ball Grid Array (BGA) 8.15x 6.15 mm Package

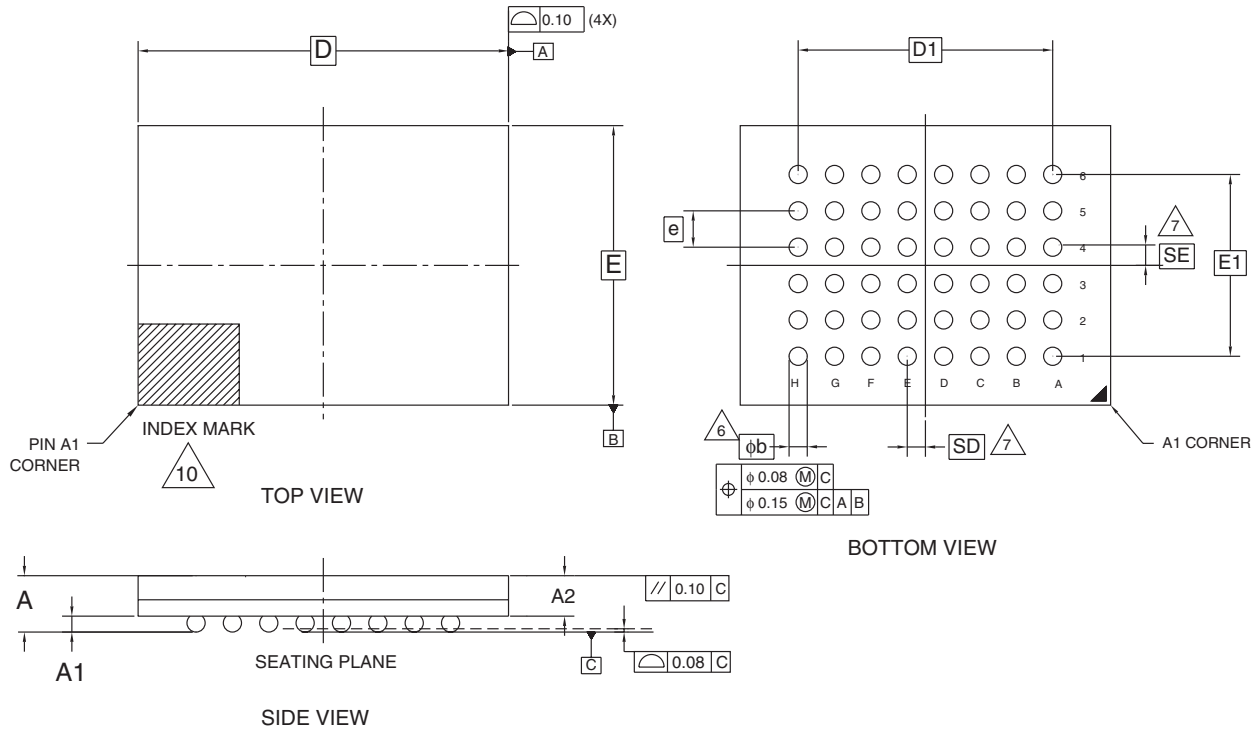

PACKAGE	VBK 048			NOTE
JEDEC	N/A			
	8.15 mm x 6.15 mm NOM PACKAGE			
SYMBOL	MIN	NOM	MAX	
A	---	---	1.00	OVERALL THICKNESS
A1	0.18	---	---	BALL HEIGHT
A2	0.62	---	0.76	BODY THICKNESS
D	8.15 BSC.			BODY SIZE
E	6.15 BSC.			BODY SIZE
D1	5.60 BSC.			BALL FOOTPRINT
E1	4.00 BSC.			BALL FOOTPRINT
MD	8			ROW MATRIX SIZE D DIRECTION
ME	6			ROW MATRIX SIZE E DIRECTION
N	48			TOTAL BALL COUNT
φb	0.35	---	0.43	BALL DIAMETER
e	0.80 BSC.			BALL PITCH
SD / SE	0.40 BSC.			SOLDER BALL PLACEMENT
	---			DEPOPULATED SOLDER BALLS

NOTES:

- DIMENSIONING AND TOLERANCING PER ASME Y14.5M-1994.
- ALL DIMENSIONS ARE IN MILLIMETERS.
- BALL POSITION DESIGNATION PER JESD 95-1, SPP-010 (EXCEPT AS NOTED).
- [e] REPRESENTS THE SOLDER BALL GRID PITCH.
- SYMBOL "MD" IS THE BALL ROW MATRIX SIZE IN THE "D" DIRECTION.  
SYMBOL "ME" IS THE BALL COLUMN MATRIX SIZE IN THE "E" DIRECTION.  
N IS THE TOTAL NUMBER OF SOLDER BALLS.
- [6] DIMENSION "b" IS MEASURED AT THE MAXIMUM BALL DIAMETER IN A PLANE PARALLEL TO DATUM C.
- [7] SD AND SE ARE MEASURED WITH RESPECT TO DATUMS A AND B AND DEFINE THE POSITION OF THE CENTER SOLDER BALL IN THE OUTER ROW.  
WHEN THERE IS AN ODD NUMBER OF SOLDER BALLS IN THE OUTER ROW PARALLEL TO THE D OR E DIMENSION, RESPECTIVELY, SD OR SE = 0.000.  
WHEN THERE IS AN EVEN NUMBER OF SOLDER BALLS IN THE OUTER ROW, SD OR SE = [e/2]
- NOT USED.
- "+" INDICATES THE THEORETICAL CENTER OF DEPOPULATED BALLS.
- [10] A1 CORNER TO BE IDENTIFIED BY CHAMFER, LASER OR INK MARK, METALLIZED MARK INDENTATION OR OTHER MEANS.

3338 \ 16-038.25 \ 10.05.04

## VBU056—Ball Fine-pitch Ball Grid Array (BGA) 9 x 7 mm Package

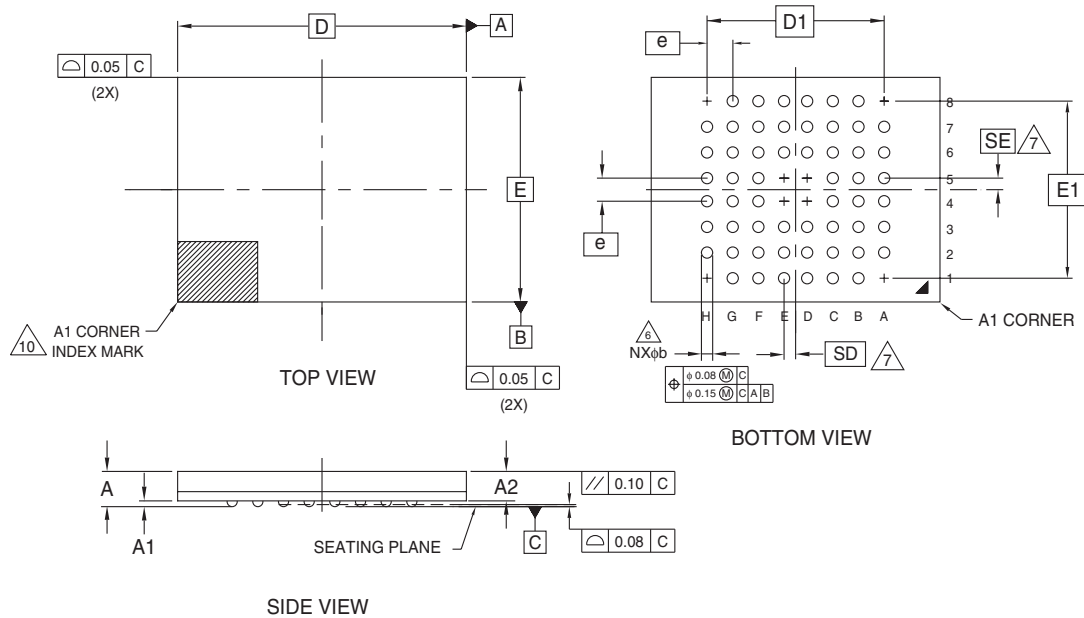

PACKAGE	VBU 056			
JEDEC	N/A			
	9.00 mm x 7.00 mm NOM PACKAGE			
SYMBOL	MIN	NOM	MAX	NOTE
A	---	---	1.00	OVERALL THICKNESS
A1	0.17	---	---	BALL HEIGHT
A2	0.62	---	0.76	BODY THICKNESS
D	9.00 BSC.			BODY SIZE
E	7.00 BSC.			BODY SIZE
D1	5.60 BSC.			BALL FOOTPRINT
E1	5.60 BSC.			BALL FOOTPRINT
MD	8			ROW MATRIX SIZE D DIRECTION
ME	8			ROW MATRIX SIZE E DIRECTION
N	56			TOTAL BALL COUNT
$\phi b$	0.35	0.40	0.45	BALL DIAMETER
e	0.80 BSC.			BALL PITCH
SD / SE	0.40 BSC.			SOLDER BALL PLACEMENT
	A1,A8,D4,D5,E4,E5,H1,H8			DEPOPULATED SOLDER BALLS

NOTES:

- DIMENSIONING AND TOLERANCING PER ASME Y14.5M-1994.
- ALL DIMENSIONS ARE IN MILLIMETERS.
- BALL POSITION DESIGNATION PER JEDEC 95-1, SPP-010 (EXCEPT AS NOTED).
- $\square e$  REPRESENTS THE SOLDER BALL GRID PITCH.
- SYMBOL "MD" IS THE BALL ROW MATRIX SIZE IN THE "D" DIRECTION.  
SYMBOL "ME" IS THE BALL COLUMN MATRIX SIZE IN THE "E" DIRECTION.  
N IS THE TOTAL NUMBER OF SOLDER BALLS.
- DIMENSION "b" IS MEASURED AT THE MAXIMUM BALL DIAMETER IN A PLANE PARALLEL TO DATUM C.
- SD AND SE ARE MEASURED WITH RESPECT TO DATUMS A AND B AND DEFINE THE POSITION OF THE CENTER SOLDER BALL IN THE OUTER ROW.  
WHEN THERE IS AN ODD NUMBER OF SOLDER BALLS IN THE OUTER ROW PARALLEL TO THE D OR E DIMENSION, RESPECTIVELY, SD OR SE = 0.000.  
WHEN THERE IS AN EVEN NUMBER OF SOLDER BALLS IN THE OUTER ROW, SD OR SE =  $\frac{e}{2}$
- NOT USED.
- "+" INDICATES THE THEORETICAL CENTER OF DEPOPULATED BALLS.
- A1 CORNER TO BE IDENTIFIED BY CHAMFER, LASER OR INK MARK, METALLIZED MARK INDENTATION OR OTHER MEANS.

34401\_16-038.25\01.13.05

## Revision Summary

### Revision A (October 13, 2004)

Initial Release.

### Revision A1 (December 17, 2004)

Secured Silicon Sector Flash Memory Region

Updated Secured Silicon Sector address table with addresses in x8-mode.

DC Characteristics (CMOS Compatible)

$I_{LIT}$  re-specified over temperature.

Corrected WP#/ACC input load current footnote.

### Revision A2 (January 28, 2005)

Global: Added S29GL032A information.

### Revision A3 (April 22, 2005)

Added S29GL016A information.

Corrected Secured Silicon Sector Indicator Bit in [Table 15](#).

### Revision A4 (July 29, 2005)

Corrected S29GL032A fine-pitch BGA package description from VBN048 to VBK048.

Corrected S29GL016A information in Table 15.

Corrected S29GL016A information in Table 17.

Updated Ordering Information and Valid Combinations for S29GL016A, S29GL032A, and S29GL064A. Added requirements for MCP Cellular Handsets.

Added VBU056 Connection Diagram and VBU056 Package Dimension drawings

### Revision A5 (January 11, 2006)

Added model numbers 01 and 02 to ordering information section and autoselect codes table.

Corrected sector address bit range in S29GL064A table for models R3, W3 and table for models R4 and W4.

Replaced model numbers W1, W2 with W3, W4 in DQ7 to DQ0 section of sector address table.



**Colophon**

The products described in this document are designed, developed and manufactured as contemplated for general use, including without limitation, ordinary industrial use, general office use, personal use, and household use, but are not designed, developed and manufactured as contemplated (1) for any use that includes fatal risks or dangers that, unless extremely high safety is secured, could have a serious effect to the public, and could lead directly to death, personal injury, severe physical damage or other loss (i.e., nuclear reaction control in nuclear facility, aircraft flight control, air traffic control, mass transport control, medical life support system, missile launch control in weapon system), or (2) for any use where chance of failure is intolerable (i.e., submersible repeater and artificial satellite). Please note that Spansion will not be liable to you and/or any third party for any claims or damages arising in connection with above-mentioned uses of the products. Any semiconductor devices have an inherent chance of failure. You must protect against injury, damage or loss from such failures by incorporating safety design measures into your facility and equipment such as redundancy, fire protection, and prevention of over-current levels and other abnormal operating conditions. If any products described in this document represent goods or technologies subject to certain restrictions on export under the Foreign Exchange and Foreign Trade Law of Japan, the US Export Administration Regulations or the applicable laws of any other country, the prior authorization by the respective government entity will be required for export of those products.

**Trademarks and Notice**

The contents of this document are subject to change without notice. This document may contain information on a Spansion product under development by Spansion LLC. Spansion LLC reserves the right to change or discontinue work on any product without notice. The information in this document is provided as is without warranty or guarantee of any kind as to its accuracy, completeness, operability, fitness for particular purpose, merchantability, non-infringement of third-party rights, or any other warranty, express, implied, or statutory. Spansion LLC assumes no liability for any damages of any kind arising out of the use of the information in this document.

Copyright © 2004 – 2006 Spansion LLC. All rights reserved. Spansion, the Spansion logo, MirrorBit, combinations thereof, and ExpressFlash are trademarks of Spansion LLC. Other company and product names used in this publication are for identification purposes only and may be trademarks of their respective companies.