

4-channel digital audio system with FFX™ driver

Features

- High efficiency FFX™ class-D modulator
- 100-dB dynamic range
- Two stereo channels with I²S input/output data interface
- 16-bit stereo ADC input with PGA and microphone biasing
- Analog and digital muxing/mixing capability
- 4-channel input sample rate converter (8 kHz to 192 kHz)
- Four channels of 24-bit audio processing
- Flexible channel mapping and routing
- Output configurations:
 - 2.0
 - 2.1
 - 4.0
 - Mono
- Embedded CMOS bridge: up to 0.5 W/channel
- pfStart™ for pop-free single-ended operations
- Play and record simultaneous operation
- Pre and post mix stages
- Individual channel and master gain/attenuation

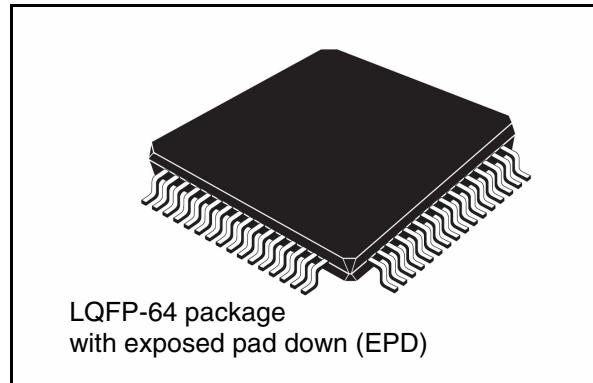

- Digital gain/attenuation -105 dB to +36 dB in 0.5-dB steps
- Soft volume update and muting
- DC-blocking selectable high-pass filter
- Selectable de-emphasis filter
- Up to 13 28-bit user programmable biquads (EQ) per channel
- Bass/treble tone control
- Ternary, binary or phase shift modulation
- PWM output
- Headphone output with jack detector
- I²C control.

Table 1. Device summary

| Order code | Temperature range | Package | Packaging |
|------------|-------------------|-------------|---------------|
| STA321 | 0 to 70 °C | LQFP-64 EPD | Tray |
| STA321TR | 0 to 70 °C | LQFP-64 EPD | Tape and reel |

Contents

- 1 Overview 9**
- 2 Pin description 10**
- 3 Electrical specifications 13**
 - 3.1 Absolute maximum ratings 13
 - 3.2 Recommended operating conditions 13
 - 3.3 Electrical characteristics 14
 - 3.4 Embedded crystal oscillator 17
 - 3.5 Embedded DC regulator 19
- 4 Power-up and power-down sequences 20**
 - 4.1 Device power-up 20
 - 4.2 Software power-down mode 21
 - 4.2.1 Configuration example 22
 - 4.3 Hardware power-down mode 23
 - 4.3.1 Mild power-down 25
 - 4.3.2 Full power-down 27
- 5 Clock management 29**
 - 5.1 System clock 30
 - 5.1.1 Configuration example 30
 - 5.2 Peripheral clock manager 31
 - 5.3 Fractional PLL 31
 - 5.3.1 PLL block description 31
 - 5.3.2 Output frequency computation 32
- 6 Digital processing stage 34**
 - 6.1 Signal processing flow 34
 - 6.2 Sampling rate converter 35
 - 6.3 Pre-EQ mix 1 and post-EQ mix 36
 - 6.3.1 Presets 37
 - 6.4 Pre scaler 37

| | | |
|----------|---|-----------|
| 6.4.1 | Presets | 37 |
| 6.5 | Equalization, tone control and effects | 37 |
| 6.6 | Biquads | 39 |
| 6.6.1 | Presets | 39 |
| 6.7 | High-pass filter | 39 |
| 6.8 | Deemphasis filter | 40 |
| 6.9 | Bass and treble control | 41 |
| 6.9.1 | Configuration example | 42 |
| 6.10 | Programmable delay | 42 |
| 6.10.1 | Presets | 42 |
| 6.11 | Volume and mute control | 42 |
| 6.12 | Limiter (clamping) | 43 |
| 6.13 | FFX channel re-mapping | 43 |
| 6.14 | Memory programming | 44 |
| 6.14.1 | Writing one coefficient/location to RAM | 44 |
| 6.14.2 | Writing a set of five coefficients/locations to RAM | 45 |
| 6.14.3 | Reading a set of five coefficients/locations from RAM | 46 |
| 6.14.4 | RAM mapping | 47 |
| 7 | FFX | 52 |
| 7.1 | Functional description | 52 |
| 7.2 | Modulation schemes | 52 |
| 7.3 | PWM shift feature | 55 |
| 7.4 | Ternary mode | 56 |
| 7.5 | Minimum pulse limitation | 56 |
| 7.6 | Headphone modulation | 57 |
| 7.7 | pfStart™ operation | 58 |
| 7.8 | PWM00 output | 59 |
| 8 | CMOS power stage | 60 |
| 9 | Fault detection and recovery | 63 |
| 9.1 | External amplifier | 63 |
| 9.2 | CMOS bridge | 63 |

| | | |
|-----------|---|------------|
| 10 | ADC | 64 |
| | 10.1 Description | 64 |
| | 10.2 Application schematic | 65 |
| | 10.2.1 Configuration example | 65 |
| 11 | Serial audio interface | 66 |
| | 11.1 Master mode | 66 |
| | 11.2 Slave mode | 67 |
| | 11.3 Serial formats | 68 |
| | 11.3.1 Right justified | 68 |
| | 11.3.2 Left justified | 68 |
| | 11.3.3 DSP | 69 |
| | 11.3.4 I ² S | 69 |
| | 11.3.5 PCM/IF (non-delayed mode) | 69 |
| | 11.3.6 PCM/IF (delayed mode) | 70 |
| | 11.4 Invalid detection | 71 |
| 12 | Headphone detection | 72 |
| | 12.1 Applications circuits | 73 |
| | 12.2 Configuration example | 74 |
| 13 | I²C interface | 75 |
| | 13.1 Communication protocol | 75 |
| | 13.1.1 Data transition and change | 75 |
| | 13.1.2 Start condition | 75 |
| | 13.1.3 Stop condition | 75 |
| | 13.1.4 Data input | 75 |
| | 13.1.5 Device addressing | 75 |
| | 13.1.6 Write operation | 75 |
| | 13.1.7 Read operation | 76 |
| 14 | Register description | 77 |
| 15 | I²C disabled (microless) mode | 150 |
| 16 | Package mechanical data | 152 |

| | | |
|-----------|--|------------|
| 17 | Glossary | 154 |
| 18 | Trademarks and other acknowledgements | 155 |
| 19 | Revision history | 156 |

List of tables

| | | |
|-----------|---|-----|
| Table 1. | Device summary | 1 |
| Table 2. | Pin list | 10 |
| Table 3. | Power supply pin list | 12 |
| Table 4. | Absolute maximum ratings | 13 |
| Table 5. | Recommended operating conditions | 13 |
| Table 6. | Electrical specifications | 14 |
| Table 7. | Oscillator specifications | 18 |
| Table 8. | Power-up signal description | 20 |
| Table 9. | Startup timings | 21 |
| Table 10. | Configuration example | 21 |
| Table 11. | Registers for power-down | 21 |
| Table 12. | Example configurations for power-down | 22 |
| Table 13. | Frequently used signals | 24 |
| Table 14. | Clock control registers | 29 |
| Table 15. | Clock characteristics | 30 |
| Table 16. | Register setup to provide sys_clk from MCLK to PLL | 30 |
| Table 17. | Input division factor (IDF) | 32 |
| Table 18. | Loop division factor (LDF) | 33 |
| Table 19. | Channel mapping | 36 |
| Table 20. | EQ control signals | 38 |
| Table 21. | Selecting EQ curves | 42 |
| Table 22. | RAM mapping for processing stage | 47 |
| Table 23. | Modulation type with register programming | 54 |
| Table 24. | CMOS bridge signal descriptions | 60 |
| Table 25. | Power output (at 1% THD) in headphone mode | 61 |
| Table 26. | Logic circuit at bridge input | 62 |
| Table 27. | Example register settings for ADC | 65 |
| Table 28. | Timing parameters for master mode | 67 |
| Table 29. | Timing parameters for slave mode | 67 |
| Table 30. | Headphone 1 detector | 72 |
| Table 31. | Headphone 2 detector | 72 |
| Table 32. | Headphone detection configuration sequence for binary SE | 74 |
| Table 33. | Headphone detection configuration sequence for binary headphone | 74 |
| Table 34. | Register summary | 77 |
| Table 35. | Bass/treble filter gains used in register addresses 0x78 - 0x7F | 115 |
| Table 36. | LQFP-64L EPD dimensions | 153 |
| Table 37. | Document revision history | 156 |

List of figures

| | | |
|------------|--|----|
| Figure 1. | STA321 block diagram | 9 |
| Figure 2. | Pin out | 10 |
| Figure 3. | Test circuit | 17 |
| Figure 4. | Oscillator configuration | 17 |
| Figure 5. | Equivalent circuit of crystal and external components | 18 |
| Figure 6. | Embedded DC regulator scheme | 19 |
| Figure 7. | Startup sequence | 20 |
| Figure 8. | Hardware power-done sequence | 23 |
| Figure 9. | Hardware powerdown sequence (mild mode) | 26 |
| Figure 10. | Hardware power-down sequence (full mode) | 28 |
| Figure 11. | Clock management scheme | 29 |
| Figure 12. | PLL block diagram | 31 |
| Figure 13. | Processing flow | 34 |
| Figure 14. | Processing data multiplexer | 34 |
| Figure 15. | SAI_out data multiplexer | 35 |
| Figure 16. | Sample rate converter block diagram | 35 |
| Figure 17. | Mixers block diagram | 36 |
| Figure 18. | EQ/tone block diagram | 37 |
| Figure 19. | Biquad coefficient selection | 38 |
| Figure 20. | Biquad filter | 39 |
| Figure 21. | High-pass filter frequency response | 39 |
| Figure 22. | Deemphasis filter frequency response | 40 |
| Figure 23. | Frequency responses of treble control at 1-dB gain steps | 41 |
| Figure 24. | Frequency responses of bass control at 1-dB gain steps | 41 |
| Figure 25. | FFX re-mapping | 43 |
| Figure 26. | Writing RAM location | 44 |
| Figure 27. | Writing five contiguous RAM locations | 45 |
| Figure 28. | Reading five contiguous RAM locations | 46 |
| Figure 29. | FFX processing schematic | 52 |
| Figure 30. | PWM modes for outputs A and B | 53 |
| Figure 31. | Modulation waveforms corresponding to Table 23 | 54 |
| Figure 32. | New phase shift modulation with shift feature | 55 |
| Figure 33. | Ternary modulation | 56 |
| Figure 34. | Modulation for headphones | 57 |
| Figure 35. | Digital pop-free ramp implementation | 58 |
| Figure 36. | CMOS half bridge block diagram | 60 |
| Figure 37. | Analog pop-free schematic | 61 |
| Figure 38. | Analog pop-free start-up and switch-off sequence | 62 |
| Figure 39. | ADC front-end block diagram | 64 |
| Figure 40. | Typical connections for power supplies and inputs | 65 |
| Figure 41. | SAI typical sampling rates | 66 |
| Figure 42. | Timing diagram for master mode | 66 |
| Figure 43. | Timing diagram for slave mode | 67 |
| Figure 44. | Right justified serial format | 68 |
| Figure 45. | Left justified serial format | 68 |
| Figure 46. | DSP serial format | 69 |
| Figure 47. | I ² S serial format | 69 |
| Figure 48. | PCM (non-delayed) serial format | 69 |

| | | |
|------------|--|-----|
| Figure 49. | PCM (delayed) serial format | 70 |
| Figure 50. | Invalid input detection schematic | 71 |
| Figure 51. | Headphone detection circuit for single-ended configuration | 73 |
| Figure 52. | Headphone detection circuit for binary HP configuration | 73 |
| Figure 53. | I ² C write operations | 76 |
| Figure 54. | I ² C read operations | 76 |
| Figure 55. | Microless mode block diagram | 150 |
| Figure 56. | LQFP-64L EPD outline drawing | 152 |

1 Overview

The STA321 is a single chip solution for digital audio processing applications of up to 4.0 channels.

The STA321 is part of the Sound Terminal™ family that together with the digital power stage provides full digital audio streaming to the speaker, offering cost effectiveness, low energy dissipation and sound enrichment.

The STA321 input section consists of two multiplexed stereo analog inputs, a 16-bit ADC and two independent digital input interfaces. The serial audio data input interface accepts all possible formats, including the popular I²S format. There is also a digital output interface fed by the ADC or by the digitally processed signals.

The device has a full assortment of digital processing features. This includes sample rate converter, pre and post mixing, up to 13 programmable 28-bit biquads (EQ) per channel, bass/treble tone control and DRC. The embedded headphone detector indicates when headphone jack is inserted.

The STA321 provides four independent channels of FFX™ output capabilities. In conjunction with a power device, it provides high-quality, high-efficiency, all digital amplification.

The embedded CMOS bridge supplies up to 0.5 W into an 8-Ω load and 70 mW into a 16-Ω load for the headphones output.

Figure 1. STA321 block diagram

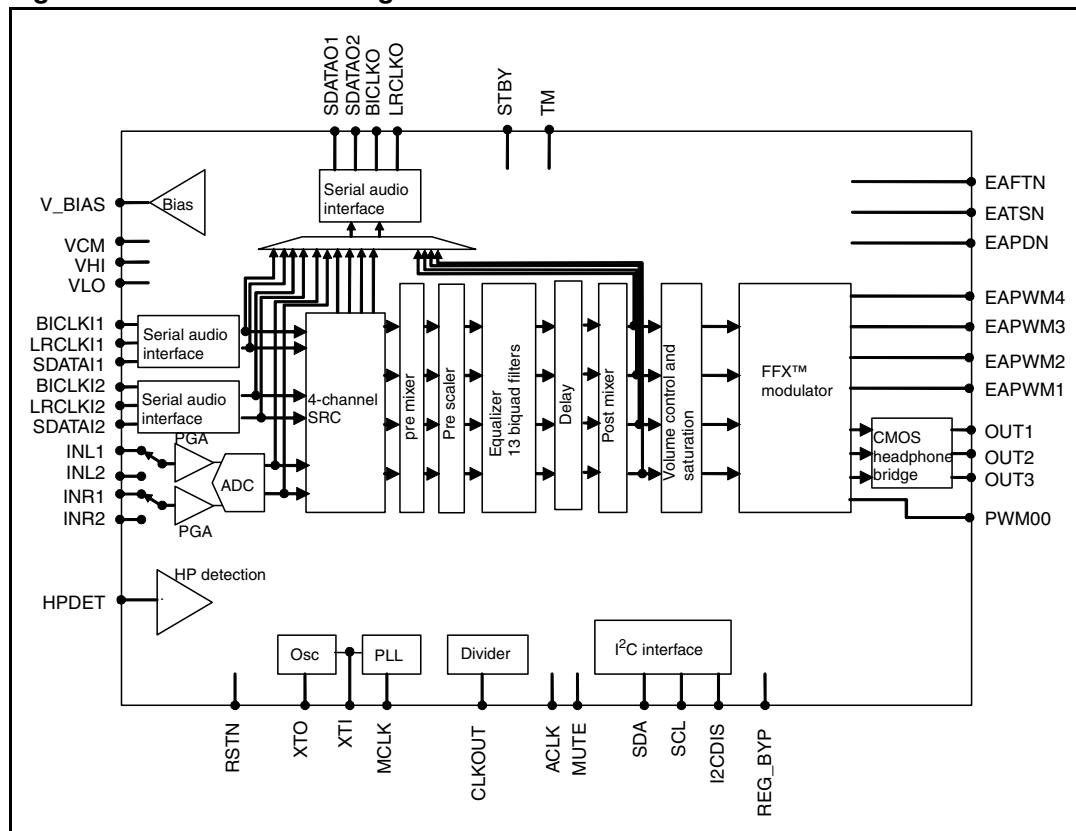

2 Pin description

Figure 2. Pin out

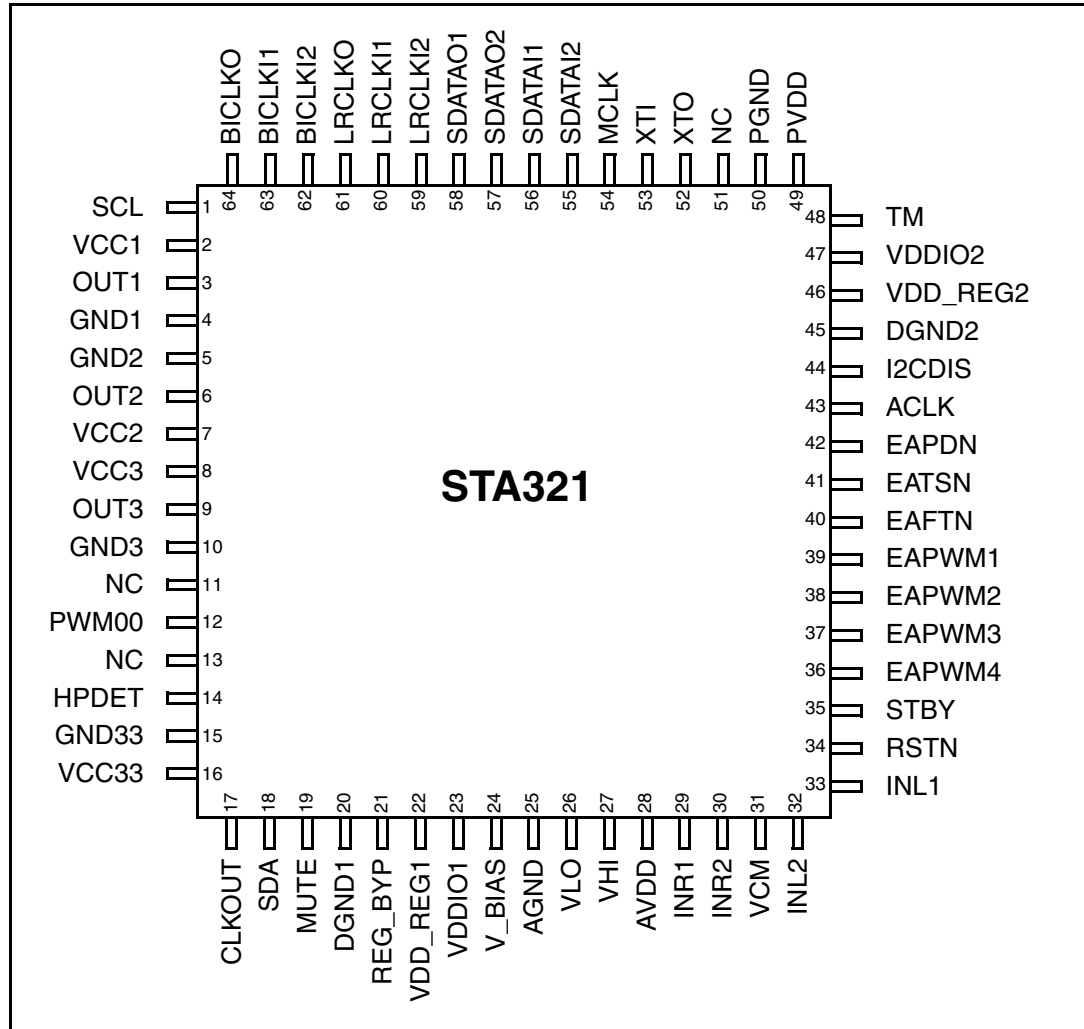

Table 2. Pin list

| Pin | Pull | Name | Type | Description |
|-----|------|-------|--------------------------|--|
| 1 | - | SCL | In (digital), schmitt tr | I ² C serial clock, schmitt trigger input |
| 3 | - | OUT1 | Out (analog) | HP/line-out PWM 1 |
| 6 | - | OUT2 | Out (analog) | HP/line-out PWM 2 |
| 9 | - | OUT3 | Out (analog) | HP/line-out PWM 3 |
| 11 | - | NC | - | Not connected |
| 12 | - | PWM00 | Out (digital) | Auxiliary PWM |
| 13 | - | NC | - | Not connected |
| 14 | - | HPDET | In (analog) | Headphone detection |

Table 2. Pin list (continued)

| Pin | Pull | Name | Type | Description |
|-----|------|------------|--------------------------|--|
| 17 | - | CLKOUT | Out (digital) | Buffered clock output |
| 18 | - | SDA | In/Out (digital) | I ² C serial data |
| 19 | H | MUTE | In (digital) | Mute (active high) |
| 21 | - | REG_BYPASS | In (analog) | DC regulator bypass: 0: normal operation, regulator enabled 1: regulator bypassed |
| 24 | - | BIAS | In/Out (analog) | ADC microphone bias voltage |
| 26 | - | VLO | In (analog) | ADC low reference voltage |
| 27 | - | VHI | In (analog) | ADC high reference voltage |
| 29 | - | INR1 | In/Out (analog) | ADC right channel line input1 |
| 30 | - | INR2 | In/Out (analog) | ADC right channel line input2 |
| 31 | - | VCM | In/Out (analog) | ADC common mode voltage |
| 32 | - | INL2 | In (analog) | ADC left channel line input2 or microphone input2 |
| 33 | - | INL1 | In (analog) | ADC left channel line input1 or microphone input1 |
| 34 | H | RSTN | In (digital) | Reset: 0: reset state 1: normal operation |
| 35 | - | STBY | In (digital) | Standby mode: 0: normal operation 1: power-down |
| 36 | - | EAPWM4 | Out (digital) | External amplifier PWM 4B |
| 37 | - | EAPWM3 | Out (digital) | External amplifier PWM 4A |
| 38 | - | EAPWM2 | Out (digital) | External amplifier PWM 3B |
| 39 | - | EAPWM1 | Out (digital) | External amplifier PWM 3A |
| 40 | H | EAFTN | Out (digital) | External power fault signal: 0: fault 1: normal operational mode |
| 41 | - | EATSN | Out (digital) | External amplifier control: 0: active 1: 3-state |
| 42 | - | EAPDN | Out (digital) | External amplifier powerdown (active low) |
| 43 | - | ACLK | In (digital), schmitt tr | Reserved pin, connect to ground |
| 44 | L | I2CDIS | In (digital) | I ² C disable: 0: I ² C enabled 1: I ² C disabled |
| 48 | L | TM | In (digital) | Test mode: 0: normal operation |
| 51 | - | NC | - | Not connected |

Table 2. Pin list (continued)

| Pin | Pull | Name | Type | Description |
|-----|------|---------|--------------------------|--|
| 52 | - | XTO | Out (digital), 1.8 V | Crystal output |
| 53 | - | XTI | In (digital), 1.8 V | Crystal input or master clock input |
| 54 | - | MCLK | In (digital), schmitt tr | Master clock input 3.3-V compatible, schmitt input |
| 55 | - | SDATAI2 | In (digital) | Input serial audio interface data |
| 56 | - | SDATAI1 | In (digital) | Input serial audio interface data |
| 57 | - | SDATAO2 | Out (digital) | Output serial audio interface data |
| 58 | - | SDATAO1 | Out (digital) | Output serial audio interface data |
| 59 | - | LRCLKI2 | In/Out (digital) | Input serial audio interface L/R-clock |
| 60 | - | LRCLKI1 | In/Out (digital) | Input serial audio interface L/R-clock |
| 61 | - | LRCLKO | In/Out (digital) | Output serial audio interface L/R-clock (volume DOWN when I2CDIS=1) |
| 62 | - | BICKI2 | In/Out (digital) | Input serial audio interface bit clock |
| 63 | - | BICKI1 | In/Out (digital) | Input serial audio interface bit clock |
| 64 | - | BICKO | In/Out (digital) | Output serial audio interface bit clock (volume UP when I2CDIS=1) |

Table 3. Power supply pin list

| Number | Name | Type | Description |
|--------|----------|--------|----------------------------------|
| 2 | VCC1 | Supply | CMOS bridge channel 1 supply |
| 4 | GND1 | Ground | CMOS bridge channel 1 ground |
| 5 | GND2 | Ground | CMOS bridge channel 2 ground |
| 7 | VCC2 | Supply | CMOS bridge channel 2 supply |
| 8 | VCC3 | Supply | CMOS bridge channel 3 supply |
| 10 | GND3 | Ground | CMOS bridge channel 3 ground |
| 15 | GND33 | Ground | CMOS bridge level shifter ground |
| 16 | VCC33 | Supply | CMOS bridge level shifter supply |
| 20 | DGND1 | Ground | Digital ground |
| 22 | VDD_REG1 | Supply | DC regulator unit supply |
| 23 | VDDIO1 | Supply | 3.3-V IO supply |
| 25 | AGND | Ground | ADC analog ground |
| 28 | AVDD | Supply | ADC analog supply |
| 45 | DGND2 | Ground | Digital ground |
| 46 | VDD_REG2 | Supply | DC regulator unit supply |
| 47 | VDDIO2 | Supply | 3.3-V IO supply |
| 49 | PVDD | Supply | PLL analog supply |
| 50 | PGND | Ground | PLL analog ground |

3 Electrical specifications

3.1 Absolute maximum ratings

Table 4. Absolute maximum ratings

| Pin name/Symbol | Parameter | Negative | Positive | Unit |
|--------------------|--|----------|----------|------|
| VDD_REG1, VDD_REG2 | Digital supply voltage | -0.3 | 4.0 | V |
| VDDIO1, VDDIO2 | Digital IO supply voltage | -0.3 | 4.0 | V |
| PVDD | PLL analog supply voltage | -0.3 | 4.0 | V |
| AVDD | ADC analog supply voltage | -0.3 | 4.0 | V |
| VCC1, VCC2, VCC3 | CMOS bridge supply voltage | -0.3 | 4.0 | V |
| VCC33 | CMOS bridge level shifter power supply | -0.3 | 4.0 | V |
| T _{STG} | Storage temperature | -40 | 150 | °C |
| T _{OP} | Operating junction temperature | -20 | 125 | °C |

Note: All grounds must always be within 0.3 V of each other.

3.2 Recommended operating conditions

Table 5. Recommended operating conditions

| Symbol | Parameter | Min | Typ | Max | Unit |
|---|---|------|-----|-----|------|
| V _{VDD_REG1} , V _{VDD_REG2} | Digital supply voltage | 2.5 | 3.3 | 3.6 | V |
| V _{PVDD} | PLL analog supply voltage | 2.5 | 3.3 | 3.6 | V |
| V _{AVDD} | ADC analog supply voltage | 1.8 | 3.3 | 3.6 | V |
| V _{VCC1} , V _{VCC2} , V _{VCC3} | CMOS bridge supply voltage | 1.55 | - | 3.3 | V |
| V _{VCC33} | CMOS bridge level shifter power supply. Ensure that V _{VCC33} ≤ V _{VCCx} always | 1.55 | - | 3.3 | V |
| V _{VDDIO1} , V _{VDDIO2} | 3.3-V IO supply | 2.7 | 3.3 | 3.6 | V |
| V _{IH} | High input voltage, 1.8-V pads | 1.3 | - | - | V |
| | High input voltage, 3.3-V pads | 2.0 | - | - | |
| V _{IL} | Low input voltage, 1.8-V pads | - | - | 0.6 | V |
| | Low input voltage, 3.3-V pads | - | - | 0.8 | |
| T _{amb} | Ambient temperature | 0 | - | 70 | °C |

3.3 Electrical characteristics

Unless otherwise specified, the results in [Table 6](#) below are given for the operating conditions $V_{CC} = 3.3\text{ V}$, $R_L = 32\ \Omega$, $f_{MCLK} = 12.288\text{ MHz}$, $T_{amb} = 25\text{ °C}$ and with the PLL set to default conditions.

Table 6. Electrical specifications

| Symbol | Parameter | Test conditions | Min | Typ | Max | Unit |
|----------------|---|---|--------------------|-----|------|---------------|
| General | | | | | | |
| V_{OH} | High output voltage, 1.8-V pads | - | 1.4 | - | - | V |
| | High output voltage, 3.3-V pads | - | $V_{VDDIO} - 0.15$ | - | - | |
| V_{OL} | Low output voltage, 1.8-V pads | $I_{OL} = 2\text{ mA}$ | - | - | 0.15 | V |
| | Low output voltage, 3.3-V pads | $I_{OL} = 2\text{ mA}$ | - | - | 0.15 | |
| V_{hys} | Schmitt trigger hysteresis, 3.3-V IO | - | - | 0.4 | - | V |
| R_{UP} | Pull-up resistance | - | - | 50 | - | k Ω |
| R_{DN} | Pull-down resistance | - | - | 50 | - | k Ω |
| I_{STBYIO} | Standby current, pins VDDIO1,2 | Pin STBY = 3.3 V CLKOUT disabled | - | 450 | - | μA |
| I_{DDIO} | Operating current, pins VDDIO1,2 | - | - | 3 | - | mA |
| I_{STBYL0} | Standby current, pins VDD_REG1,2 | Deep power-down, $V_{VDD_REG1,2} = 3.3\text{ V}$ | - | 450 | - | μA |
| I_{STBYL1} | Standby current, pins VDD_REG1,2 | Mild power-down, $V_{VDD_REG1,2} = 3.3\text{ V}$ | - | 2 | - | mA |
| I_{DDL1} | Operating current, pins VDD_REG1,2 | $f_{MCLK} = 12.288\text{ MHz}$, Play from SAI to CMOS bridge and EAPWM, $f_{ADC} = 48\text{ kHz}$ on SAI_out, $V_{AVDD} = 3.3\text{ V}$, $V_{VDD_REG1,2} = 3.3\text{ V}$ | - | 45 | - | mA |
| I_{STBYPD} | Pre-drive supply current in standby, pin VCC33 | - | - | 4.7 | - | μA |

Table 6. Electrical specifications (continued)

| Symbol | Parameter | Test conditions | | Min | Typ | Max | Unit |
|--------------------------------|---|---|-------------------|--------|------|--------|------------------|
| Amplifier (CMOS bridge) | | | | | | | |
| η | Output power efficiency | - | | - | 90 | - | % |
| P_{HPOUT} | Output power in HP mode with THD = 1% | 3.3-V supply | $R_L = 32 \Omega$ | - | 41 | - | mW |
| | Output power in HP mode with THD = 10% | 3.3-V supply | $R_L = 32 \Omega$ | - | 53 | - | |
| SNR | Signal to noise ratio | 20 Hz to 20 kHz | | - | 75 | - | dB |
| THD + N | Total harmonic distortion plus noise | $R_L = 32 \Omega$, HP mode | 0 dBFs In | - | 0.3 | - | % |
| | | | -6 dBFs In | - | 0.05 | - | |
| DR | Dynamic range | A-weighted | | - | 80 | - | dB |
| I_{STBYP} | Current in standby, pins VCCx | - | | - | 2 | - | μA |
| I_{DDP} | Operating current, pins VCCx | No LC filter, no load, PWM at 50% duty-cycle | | - | 1 | - | mA |
| I_{DDPD} | Pre-drive supply current in operation, pin VCC33 | No load, PWM at 50% duty-cycle | | - | 250 | 350 | μA |
| t_R | Driver rise time, pins OUT1-3 | Resistive load, see Figure 3 | | - | 5 | - | ns |
| t_F | Driver fall time, pins OUT1-3 | Resistive load, see Figure 3 | | - | 5 | - | ns |
| R_{DSON} | Headphone output stage N/P MOS on-resistance | - | | - | 500 | 700 | $\text{m}\Omega$ |
| I_{OCH} | Over-current limit for OUT1-3 to VCCx short circuit | - | | - | 1.88 | - | A |
| I_{OCL} | Over-current limit for OUT1-3 to ground short circuit | - | | - | 1.72 | - | A |
| PLL | | | | | | | |
| I_{STDBYPLL} | PLL supply current in standby | - | | - | 20 | - | μA |
| I_{DDPLL} | PLL supply current in operation | - | | - | 0.4 | 1.0 | mA |
| $f_{\text{CLKIN_Range}}$ | Input clock frequency range | - | | 2.048 | - | 49.152 | MHz |
| Duty _{CLKIN} | Input clock duty cycle | - | | 40 | - | 60 | % |
| $t_{\text{CLKIN_RF}}$ | Input clock rise/fall time | - | | - | - | 0.2 | ns |
| $f_{\text{F_INT}}$ | PFD input clock frequency | PLL_FR_CTRL = 1 | | 2.048 | - | 12.288 | MHz |
| $f_{\text{VCO_Range}}$ | Clock out range | - | | 65.536 | - | 98.304 | MHz |
| Duty _{VCO} | Clock out duty cycle | - | | 35 | - | 65 | % |
| T_{LOCK} | Lock time | - | | - | - | 200 | μs |

Table 6. Electrical specifications (continued)

| Symbol | Parameter | Test conditions | Min | Typ | Max | Unit |
|--|----------------------------------|---|-----|--------|-----|------|
| ADC | | | | | | |
| I _{DDA} | Supply current in operating mode | V _{AVDD} = 3.3V | - | 10 | 15 | mA |
| I _{STDBYA} | AVDD supply current in standby | V _{AVDD} = 3.3V | - | 2 | - | µA |
| DR | Dynamic range | 1 kHz, A-weighted V _{AVDD} = 3.3 V | - | 90 | - | dB |
| SNR _{ADC} | Signal to noise ratio | 1 kHz, A-weighted V _{AVDD} = 3.3 V | - | 92 | - | dB |
| THD _{ADC} | Total harmonic distortion | 1 kHz, -1dB V _{AVDD} = 3.3 V | - | 85 | - | dB |
| CT | Channel cross talk | V _{AVDD} = 3.3 V | - | 80 | - | dB |
| - | Group delay | F _s mode (f _S = 32 kHz) | - | 0.4 | - | ms |
| | | F _{s_by_2} mode (f _S = 16 kHz) | - | 0.7 | - | |
| | | F _{s_by_4} mode (f _S = 8 kHz) | - | 1.4 | - | |
| - | Pass band | - | - | 0.4535 | - | Fs |
| - | Pass band ripple | F _s mode (f _S = 44.1 kHz) | - | 0.08 | - | dB |
| | | F _{s_by_2} mode (f _S = 22.05 kHz) | - | 0.08 | - | |
| | | F _{s_by_4} mode (f _S = 11.025 kHz) | - | 0.08 | - | |
| - | Stop band attenuation | F _s mode (f _S = 44.1 kHz) | - | 45 | - | dB |
| | | F _{s_by_2} mode (f _S = 22.05 kHz) | - | 45 | - | |
| | | F _{s_by_4} mode (f _S = 11.025 kHz) | - | 45 | - | |
| - | Frequency response | -3 dB | - | 7 | - | Hz |
| | | -0.08 dB | - | 50 | - | Hz |
| - | Linear phase deviation | at 20 Hz | - | 19.35 | - | deg |
| - | Pass-band ripple | - | - | 0.08 | - | dB |
| Headphone detector threshold limits | | | | | | |
| E_HP1 | HP low threshold | - | - | 2.34 | - | V |
| | HP high threshold | - | - | 2.52 | - | |
| E_HP2 | HP low threshold | - | - | 0.7 | - | V |
| | HP high threshold | - | - | 0.9 | - | |

Figure 3. Test circuit

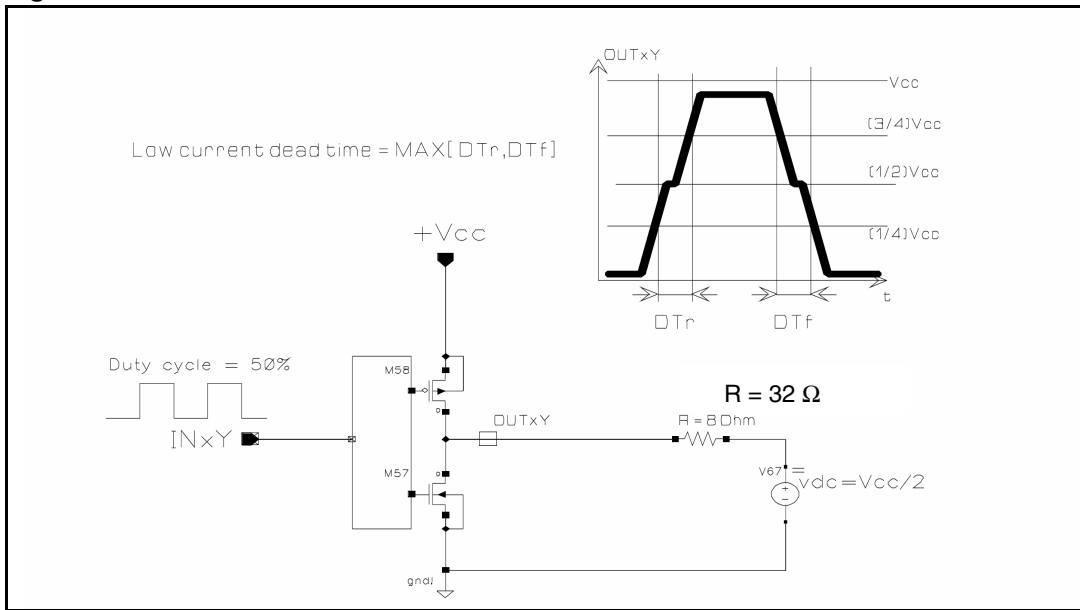

3.4 Embedded crystal oscillator

Figure 4. Oscillator configuration

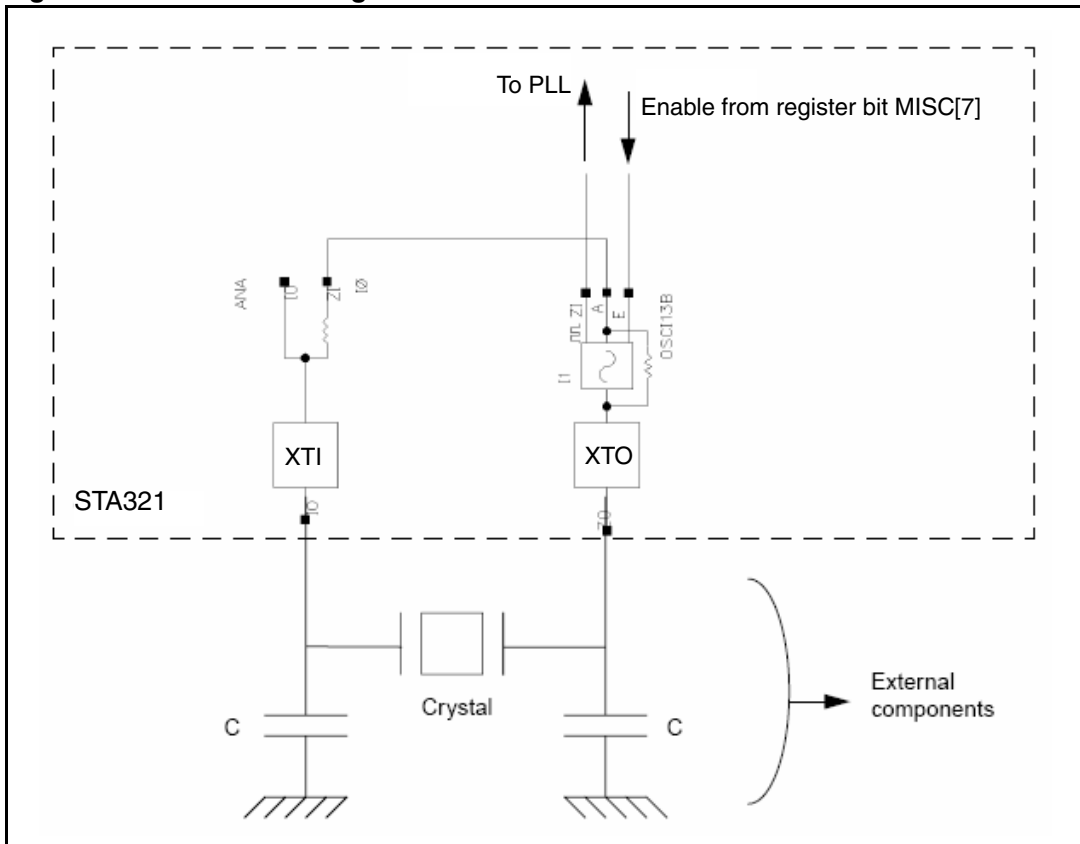

The STA321 has an integrated oscillator between pins XTI and XTO.

The architecture is a single-stage oscillator with an inverter working as an amplifier. The oscillator stage is biased by an internal resistor (of about 500 kΩ), and requires an external PI network consisting of a crystal and two capacitors as shown in *Figure 4* below. An enable feature is provided in bit 7 of register MISC (address 0xC8) to stop the oscillator and thereby to reduce power consumption.

Not all crystals operate satisfactorily with the type of oscillator used in the STA321. To find out if a crystal is suitable for this device the following transconductance formula must be evaluated and compared to the critical transconductance for the embedded oscillator:

$$G_m = R_m * \omega^2 * (C + 2 * C_o)^2 < G_{mCRITICAL} / 3$$

where ω is the crystal operating frequency, $C = C_A = C_B$, C_o and R_m are shown in *Figure 5* and $G_{mCRITICAL}$ is given in *Table 7*.

Figure 5. Equivalent circuit of crystal and external components

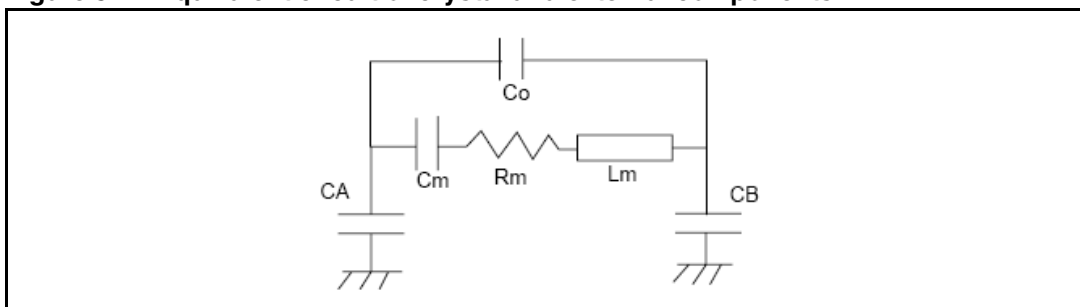

Table 7. Oscillator specifications

| Symbol | Parameter | Min | Typ | Max | Unit |
|---------------------|--|------|---------------|------|------------------|
| I_{OSC} | Oscillator power consumption with crystal connected ⁽¹⁾ | - | - | 215 | μA |
| Duty _{OSC} | Duty cycle | 46.9 | 47.8% | 48.9 | % |
| T_{UP} | Startup time | - | $15 * \tau_X$ | - | s ⁽²⁾ |
| $G_{mCRITICAL}$ | Oscillator transconductance | 1060 | - | - | μA/V |

1. If no crystal is connected then the power consumption could be much higher.
2. τ_X is the time constant of the crystal and external components; a typical value is 44 μs.

3.5 Embedded DC regulator

The power supply to the digital STA321 core and PLL is provided via embedded linear DC regulators as shown below in [Figure 6](#). When pin REG_BYPASS is tied to ground, the DC regulators are active so that a voltage in the range 2.5 V to 3.6 V applied to pins VDD_REGx or PVDD provides a regulated internal voltage to the core and the PLL. The voltages Vddi and Vddipll range from 1.55 V to 1.95 V depending on operating conditions.

Figure 6. Embedded DC regulator scheme

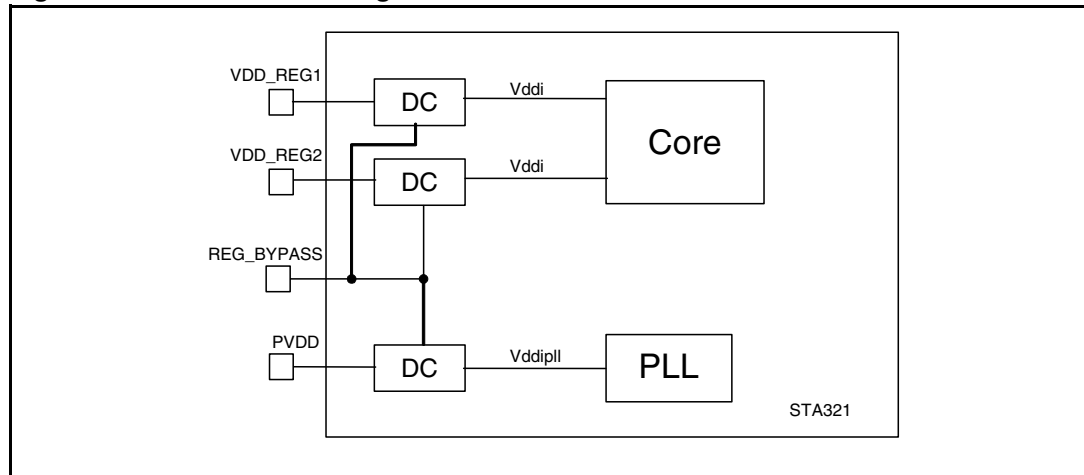

If the application allows multiple supplies or the power supply requirements are a fundamental constraint, pin REG_BYPASS can be tied high and a 1.8 V external supply can be applied directly to pins VDD_REGx and PVDD. In this case the operating range for such an external supply is 1.55 V to 1.95 V.

Embedded DC regulators imply also static power consumption that must be taken into account when the power-down modes are active. The STA321 provides a deep powerdown mode where also the regulators are active but in a low power consumption mode (see [Section 4.3.2 on page 27](#)).

4 Power-up and power-down sequences

4.1 Device power-up

After providing the power supply to the device, it is necessary to wait until the DC regulator PWUP time has elapsed before the device can be set up and used for normal operations. (see [Figure 7](#)).

Figure 7. Startup sequence

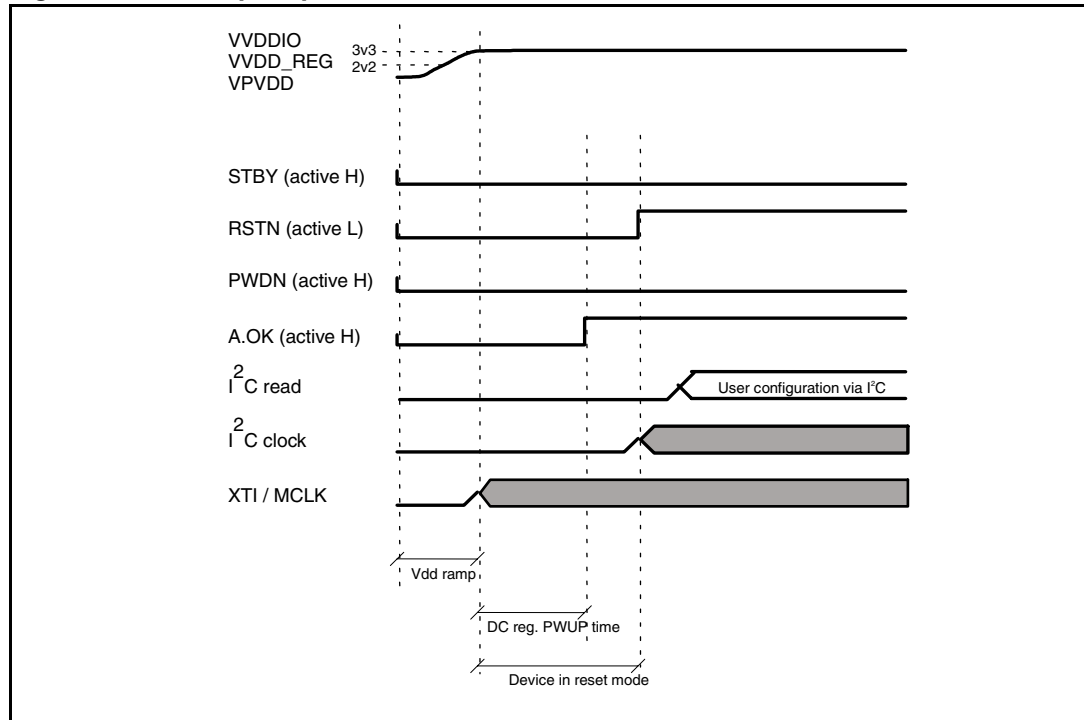

Table 8. Power-up signal description

| Signal/pin | Type | Description |
|------------------------|-----------------------|--|
| VDDIO | Supply | Power supply of the digital pads (= VDDIO1,2) |
| VDD_REG | Supply | Power supply of the system core (= VDD_REG1,2) |
| PVDD | Supply | Power supply of the PLL |
| STBY | In (digital) | External standby signal provided by the user |
| RSTN | In (digital) | External reset signal provided by the user |
| PWDN | Internal | Power-down of the DC regulator cell, controlled by the core |
| A. OK | Internal | DC regulator status, when active the 1.8 V is provided to the core |
| I ² C read | In (I ² C) | Configuration commands coming to the I ² C interface |
| I ² C clock | Internal | I ² C peripheral clock |
| XTI/MCLK | In (digital) | Clock input source |

Table 9. Startup timings

| Parameter | Description | Min | Typ | Max | Unit |
|-----------------------|--|-----|-----|-----|------|
| DC reg. power-up time | Start up time of the DC Regulator after connecting the power | - | - | 300 | µs |
| Device in reset mode | Must be greater than (VDD time + DC reg. power-up time) | - | - | - | µs |

Table 10. Configuration example

| Register address | Value | Description |
|------------------|-------|--|
| 0xC9 | 0x00 | Remove PLL bypass |
| 0xCA | 0x00 | Headphone detection polarity = 0 |
| 0xB8 | 0x4A | Configure SAI output: SAI_out1 = SAI_in1, SAI_out2 = SAI_in2 |
| 0xB7 | 0x38 | SRC source select: SRC1 = ADC, SRC2 = ADC |
| 0xC6 | 0x02 | ADC clock on |
| 0xB2 | 0xF3 | I ² S configuration |
| 0xC8 | 0x21 | Core clock on, SAI/ADC audio set to 32 kHz - 48 kHz range |
| 0xB2 | 0xD3 | SAI_out: output enabled |
| 0xA0 | 0x00 | Soft volume removed |
| 0x00 | 0x00 | Remove bridge 3-state |

4.2 Software power-down mode

The software power-down is obtained by configuring the appropriate I²C registers.

In order to obtain flexibility every peripheral has its independent, standby signal and several gating clock cells are available.

Obviously, the I²C peripheral can not be turned off in this mode, otherwise the device can recover from the power-down state only via the reset pin.

In the table below EA is embedded amplifier and CB is CMOS bridge. For complete information this table must be used in conjunction with [Chapter 14: Register description on page 77](#).

Table 11. Registers for power-down

| Description | Register bit | Address |
|---------------------|-----------------------------|----------------------------------|
| Put EA in standby | FFXCFG1 [7] | 0x00 on page 81 |
| Put CB in standby | FFXCFG1 [6] | 0x00 |
| Put PLL in standby | PLLPE [5] | 0xC4 on page 132 |
| Put ADC in standby | ADCCFG0 [3] | 0xC6 on page 133 |
| Turn core clock off | MISC [0] | 0xC8 on page 135 |
| Turn ADC clock off | ADCCFG0 [1] | 0xC6 |

Table 11. Registers for power-down (continued)

| Description | Register bit | Address |
|---------------------|--------------|------------------|
| Turn SRC clock off | CKOCFG[3] | 0xC7 on page 134 |
| Turn PROC clock off | CKOCFG[2] | 0xC7 |
| Turn FFX clock off | CKOCFG[4] | 0xC7 |

4.2.1 Configuration example

This is an example of the register setup for power-down clock. It is assumed that every peripheral is already configured and working correctly.

There are other configuration examples to help you get started please refer to other chapters and also to [Chapter 14: Register description on page 77](#) in order to get all the necessary and complementary details.

Turn off all the peripherals.

Note: The MCLK (or XTI) must be used as system clock (sys_clk) before setting the PLL to standby.

Table 12. Example configurations for power-down

| Register bit | Address | Value | Description |
|--------------------|------------------|-------|---|
| EA_STBY CB_STBY | 0x00 on page 81 | 0xC0 | Set the embedded power amplifier and CMOS bridge to power-down |
| CLK_FFX_ON | 0xC7 on page 134 | 0x0C | Turn off the FFX modulator clock |
| ADC_STBY | 0xC6 on page 133 | 0x09 | Set the ADC into standby mode |
| CLK_ADC_ON | 0xC6 | 0x80 | Turn the ADC clock off |
| CLK_PROC_ON | 0xC7 | 0x08 | Turn the processing clock off |
| CLK_SRC_ON | 0xC7 | 0x00 | Turn the sample rate converter clock to off |
| PLL_BYP_UNL | 0xC4 on page 132 | 0x80 | Bypass the PLL clock and use MCLK (or XTI) as source clock when the PLL is not locked (a safety operational mode) |
| PLL_PWDN | 0xC4 | 0xA0 | Put the PLL in standby |
| CLK_CORE_ON | 0xC8 on page 135 | 0x00 | Turning off the core clock |

4.3 Hardware power-down mode

The hardware power-down is obtained by asserting pin STBY to high.

There are two power-down options available, namely mild mode and full (or deep) mode, that could be selected using the DC_STBY_EN signal in register STBY_MODES

Figure 8 summarizes the main power-down sequence. "Power on" is the normal operating status where all the startup procedures have already been executed. The rectangular boxes indicate the steps to be done by the user whilst the rounded boxes indicate the steps done by the device.

Figure 8. Hardware power-down sequence

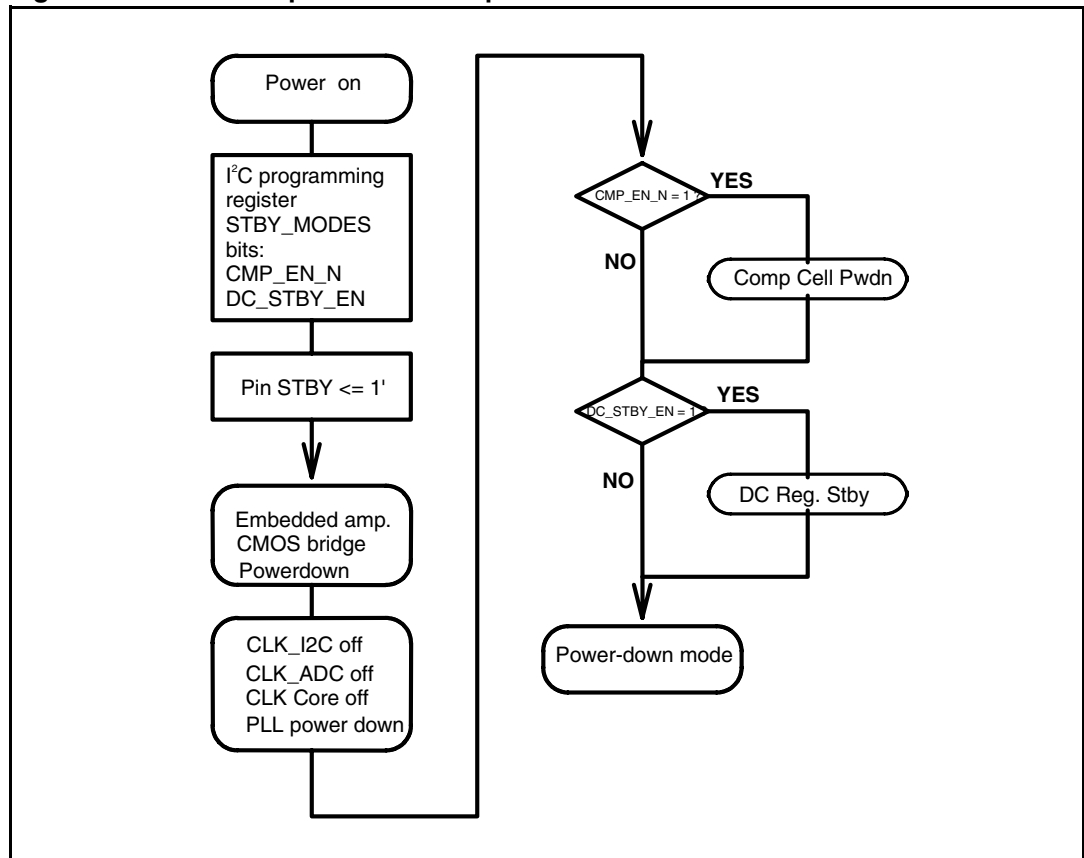

Table 13. Frequently used signals

| Name | Description |
|-----------------------|--|
| STBY | Input pin STBY on page 11 |
| PWDN DC regulator | Internal |
| A. OK DC regulator | Internal |
| CMP_EN_N | Bit 1, register STBY_MODES on page 139 |
| EA_STBY CB_STBY | Bits 7:6, register FFXCFG1 on page 81 |
| EA/CB volume | Internal |
| PLL_UNLOCK | Bit 7, register PLLST on page 132 |
| PLL_PWDN | Bit 5, register PLLPE on page 132 |
| CLK_PROC_ON | Bit 2, register CKOCFG on page 134 |
| CLK_PROC | Processing clock |
| CLK_FFX_ON | Bit 4, register CKOCFG on page 134 |
| clk_ffx | FFX clock |
| CLK_ADC_ON | Bit 1, register ADCCFG0 on page 133 |
| clk_adc | ADC clock |
| CLK_SRC_ON | Bit 3, register CKOCFG on page 134 |
| clk_src | SRC clock |
| CMP_EN_N | Bit 1, register STBY_MODES on page 139 |
| DC_STBY_EN | Bit 0, register STBY_MODES on page 139 |
| FFX_ULCK_PLL | Bits 4:3, register FFXCFG1 on page 81 |

4.3.1 Mild power-down

In this case, the device is put into a mild power-down mode.

All the peripherals are set to standby and their clocks turned off.

The I²C configuration is not required as the default values of the registers are sufficient.

- Initial conditions:
 - FFX_ULCK_PLL = 10
 - CMP_EN_N = 0
 - DC_STBY_EN = 0
- Going into power-down:

After the assertion of the pin STBY, the following actions are taken by the device:

 1. Embedded amplifier (EA) and CMOS bridge (CB) volume are set to mute (the length of this step changes according to the fade-out ramp configuration).
 2. EA and CB are put into power-down.

After the previous operation is completed:
 3. All peripherals are turned off (regardless the register settings).
 4. The PLL clock is bypassed, the system clock (sys_clk in [Figure 11 on page 29](#)) is XTI.
 5. All clocks are shut down.
- Returning to normal mode:

After the release of the pin STBY, the power-up procedure takes place:

 1. All clocks are turned on.
 2. All peripherals are restored to their previous status (based on the last register settings).
 3. If the PLL clock was the system clock it will be selected again after the locking time.
 4. The EA and the CB execute the fade-in procedure before becoming ready to be used (the length of this step changes according to the fade-in ramp configuration).

Figure 9. Hardware powerdown sequence (mild mode)

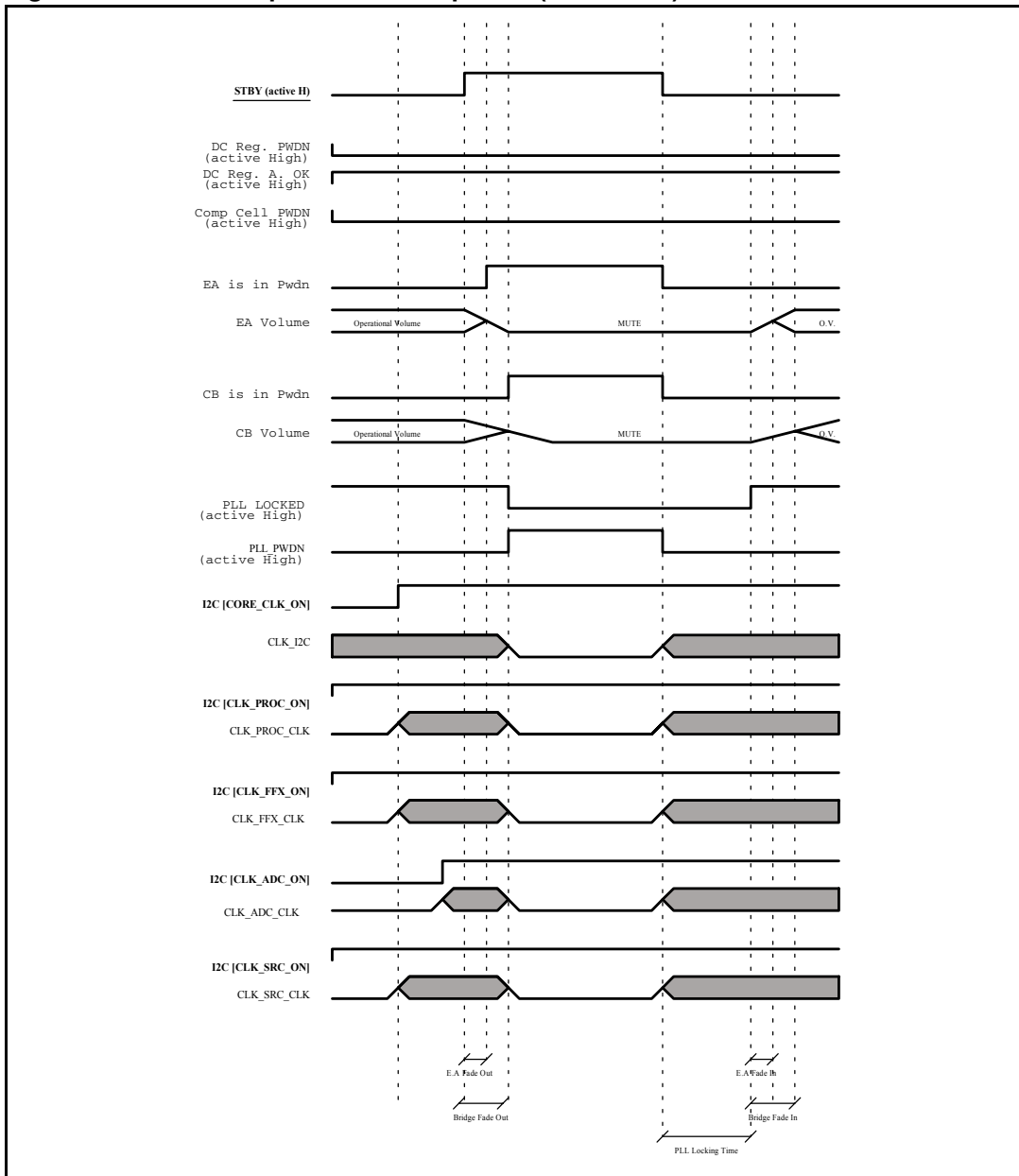

4.3.2 Full power-down

In this case the device is put into a full power-down mode.

This implies lower power consumption than the mild mode, but has a drawback in that it takes longer to execute.

- Initial conditions
 - FFX_ULCK_PLL = 10
 - CMP_EN_N = 1
 - DC_STBY_EN = 1
- Going into power-down:

This mode differs from the previous one by an additional step at the end of the power-down procedure and at the beginning of the power-up:

 1. Embedded amplifier (EA) and CMOS bridge (CB) volume are set to mute (the length of this step changes according to the fade-out ramp configuration).
 2. EA and CB are put into power-down.

After the acknowledge signals (EA is in power-down and CB is in power-down) are received:
 3. All peripherals are turned off (regardless the register settings).
 4. PLL clock is bypassed, the system clock (sys_clk in [Figure 11 on page 29](#)) is XTI.
 5. All clocks are shut down.
 6. DC regulator is put into standby mode. After this point the device is in a very low power consumption mode.
- Returning to normal mode:

After the release of pin STBY, the power-up procedure will take place:

 1. DC regulator is set to operational mode

After the acknowledge signal (DCAOK) from the DC regulator is received:
 2. All clocks are turned on.
 3. All peripherals are restored to the status based on their relative register settings.
 4. If the PLL clock was the system clock it is selected again after the locking time.
 5. The EA and the CB execute the fade-in procedure before being ready to be used (the length of this step changes according to the fade-in ramp configuration).

Figure 10. Hardware power-down sequence (full mode)

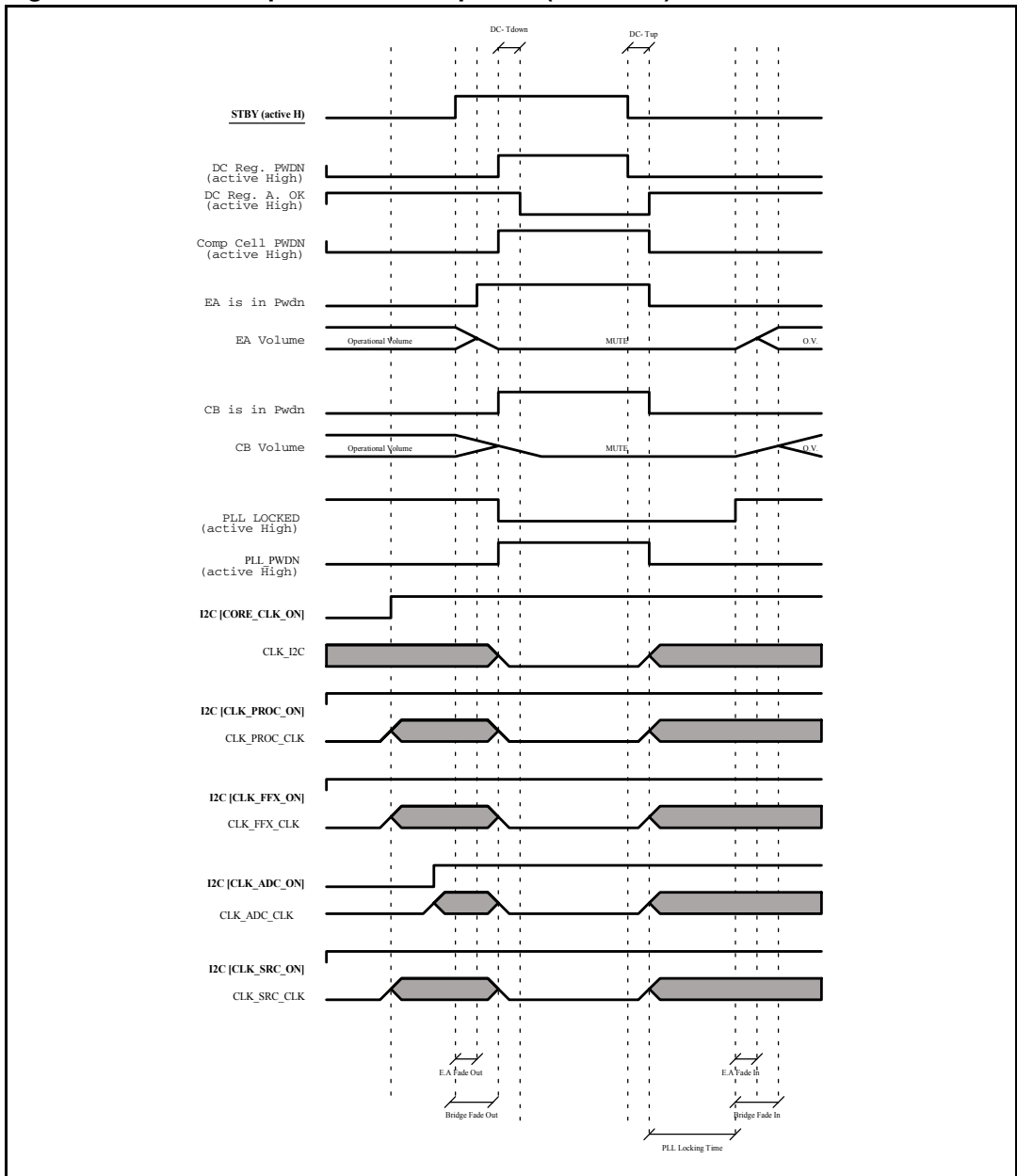

5 Clock management

Figure 11. Clock management scheme

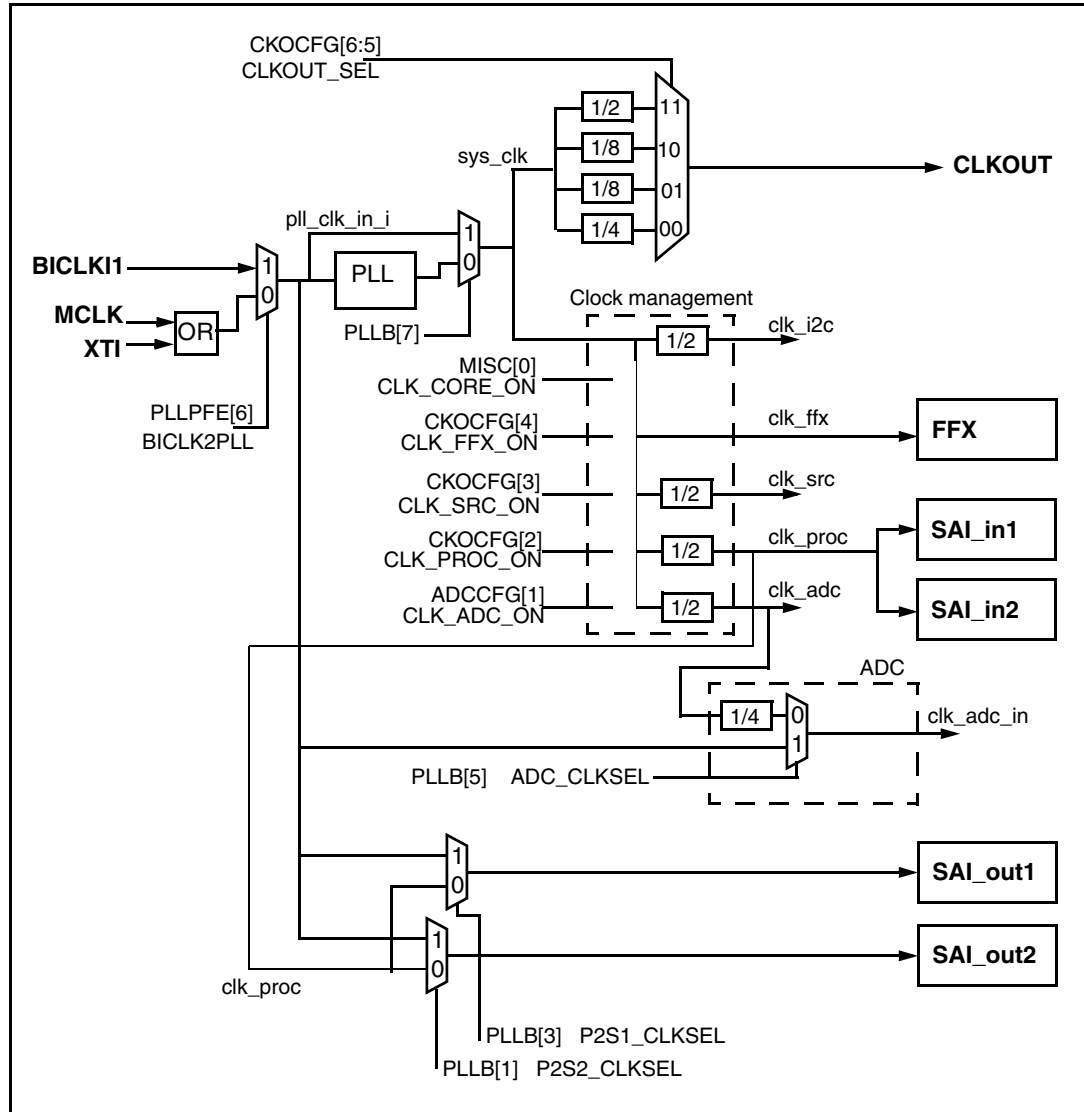

Table 14. Clock control registers

| Register Name | Address |
|-------------------------------------|---------|
| PLL on page 136 | 0xC9 |
| ADCCFG0 on page 133 | 0xC6 |
| CKOCFG on page 134 | 0xC7 |

Table 15. Clock characteristics

| Symbol | Parameter | Min | Typ | Max | Unit |
|---------------------------|------------------------------|-------|-----|--------|------|
| f _{MCLK_Range} | Input clock frequency range | 2.048 | - | 49.152 | MHz |
| Duty _{MCLK} | Input clock duty cycle | 40 | - | 60 | % |
| t _{MCLK_RF} | Input clock rise/fall time | - | - | 0.2 | ns |
| f _{XTI_Range} | Input clock frequency range | 2.048 | - | 49.152 | MHz |
| Duty _{XTI} | Input clock duty cycle | 40 | - | 60 | % |
| t _{XTI_RF} | Input clock rise/fall time | - | - | 0.2 | ns |
| f _{BICK1_Range} | Input clock frequency range | 2.048 | - | 49.152 | MHz |
| Duty _{BICK1} | Input clock duty cycle | 40 | - | 60 | % |
| t _{BICK1_RF} | Input clock rise/fall time | - | - | 0.2 | ns |
| f _{CLKOUT_Range} | Output clock frequency range | - | - | 49.152 | MHz |

5.1 System clock

Figure 11 above shows the STA321 clock management scheme with all the major clocks. As can be seen, the system clock (sys_clk) is selected from one of three sources by using register [PLLb on page 136](#):

- an external clock BICK1
- (default) an external clock XTI or MCLK (the unused one must, however, be set to 0)
- the internal PLL.

If the PLL is used there are some design constraints:

- pll_clk_in_i must be in the range: 2.048 MHz to 49.152 MHz
- pll_clk_out must be in the range: 65.536 MHz to 98.304 MHz.

The sys_clk is routed to the peripherals through the clock manager section.

5.1.1 Configuration example

This is an example of the PLL register setup. It is assumed that every peripheral is already configured and working correctly.

There are other configuration examples to help you get started please refer to other chapters and also to [Chapter 14: Register description on page 77](#) in order to get all the necessary and complementary details.

Starting with MCLK as system clock switching to PLL as source

Table 16. Register setup to provide sys_clk from MCLK to PLL

| Register | Address | Value | Description |
|----------|---------|-------|--|
| PLLPFE | 0xC4 | 0x80 | Safety operational mode: automatic use of MCLK (or XTI) as system clock if the PLL is not locked |
| PLLb | 0xC9 | 0x00 | Remove the PLL bypass and use its clock as system |

5.2 Peripheral clock manager

This block manages the clocks of the core processing peripherals ADC, FFX, PROC (including memories and SAI interfaces) and SRC.

A clock divider (by 2) is attached before every block except the FFX.

Each block is attached to a global gating cell and to a dedicated one. This allows a flexible power-consumption management because it is possible to turn off either the whole processing chain or just a single block. The only exception is the I²C peripheral clock which is disabled only when the device is in hardware power-down mode. In all the other cases this clock remains active.

5.3 Fractional PLL

The PLL specifications are given in [Table 6 on page 14](#).

Figure 12. PLL block diagram

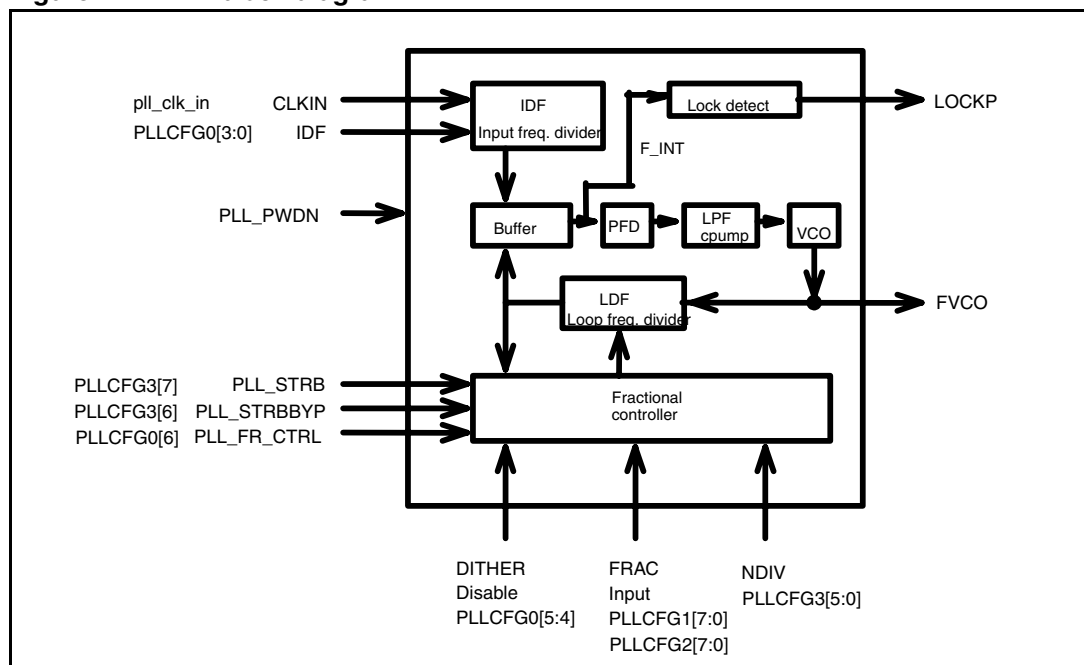

5.3.1 PLL block description

Phase/frequency detector (PFD)

This block compares the phase difference between the corresponding rising edges of the `F_INT` and the clock coming from the loop frequency divider.

It generates voltage pulses with widths proportional to the input phase error.

Charge pump and loop filter (LPF/CPUMP)

This block converts the voltage pulses from the phase/frequency detector to current pulses which charge the loop filter and generate the control voltage for the voltage controlled oscillator (VCO).

Voltage controlled oscillator (VCO)

This is the oscillator inside the PLL, which produces a frequency, f_{VCO} , on output FVCO proportional to the input control voltage.

Input frequency divider (IDF)

This frequency divider divides the PLL input clock CLKIN by the input division factor (IDF) to generate the PFD input frequency. IDF is programmed in register PLLCFG0[3:0].

Loop frequency divider (LDF)

This frequency divider is present within the PLL for dividing the VCO output by the loop division factor (LDF). LDF is programmed in register bits PLLCFG3[5:0].

Lock circuit

The output of this block, signal LOCKP, is asserted high when the PLL enters the state of coarse lock in which the output frequency is $\pm 10\%$ of the desired frequency. LOCKP is refreshed every 32 cycles of F_INT. The status bit PLL_UNLOCK is in register [PLLST](#) on [page 132](#).

5.3.2 Output frequency computation

The input clock frequency of the phase/frequency detector (PFD) is

$$f_{F_INT} = CLKIN / IDF$$

The VCO frequency depends on the value of register bit PLLCFG0.PLL_FR_CTRL such that

When PLL_FR_CTRL = 1

$$f_{VCO} = f_{F_INT} * (LDF + FRAC / 2^{16} + 1 / 2^{17})$$

and when PLL_FR_CTRL = 0

$$f_{VCO} = f_{F_INT} * LDF$$

Notes:

1. When dither is disabled (PLL_DDIS = 1), the factor $1 / 2^{17}$ is not used in the multiplication.
2. There are some limits to the input and output frequencies as given in [Table 17](#) and [Table 18](#) when selecting the values for IDF, LDF, and FRAC.
3. The LDF values of 5, 6 and 7 cannot be used when fractional synthesis mode is on, that is, when PLL_FR_CTRL = 1.
4. The fractional control bits (FRAC_INPUT) must be set to the required values before activating the fractional synthesis mode.

Table 17. Input division factor (IDF)

| IDF[3] | IDF[2] | IDF[1] | IDF[0] | Input division factor (IDF) |
|--------|--------|--------|--------|-----------------------------|
| 0 | 0 | 0 | 0 | 1 |
| 0 | 0 | 0 | 1 | 1 |
| 0 | 0 | 1 | 0 | 2 |
| ... | ... | ... | ... | ... |

Table 17. Input division factor (IDF) (continued)

| IDF[3] | IDF[2] | IDF[1] | IDF[0] | Input division factor (IDF) |
|--------|--------|--------|--------|-----------------------------|
| 1 | 1 | 1 | 0 | 14 |
| 1 | 1 | 1 | 1 | 15 |

Table 18. Loop division factor (LDF)

| NDIV[5] | NDIV[4] | NDIV[3] | NDIV[2] | NDIV[1] | NDIV[0] | Loop division factor (LDF) |
|---------|---------|---------|---------|---------|---------|----------------------------|
| 0 | 0 | 0 | 0 | x | x | NA |
| 0 | 0 | 0 | 1 | 0 | 0 | NA |
| 0 | 0 | 0 | 1 | 0 | 1 | 5 ⁽¹⁾ |
| 0 | 0 | 0 | 1 | 1 | 0 | 6 (see note 3) |
| 0 | 0 | 0 | 1 | 1 | 1 | 7 (see note 3) |
| 0 | 0 | 1 | 0 | 0 | 0 | 8 |
| ... | ... | ... | ... | ... | ... | ... |
| 1 | 1 | 0 | 1 | 1 | 0 | 54 |
| 1 | 1 | 0 | 1 | 1 | 1 | 55 |
| 1 | 1 | 1 | x | x | x | NA |

1. The LDF values of 5, 6 and 7 cannot be used when fractional synthesis mode is ON (PLL_FR_CTRL = 1)

6 Digital processing stage

6.1 Signal processing flow

The STA321 provides 4 channels of audio signal processing. The block diagram is shown in the following figure.

Figure 13. Processing flow

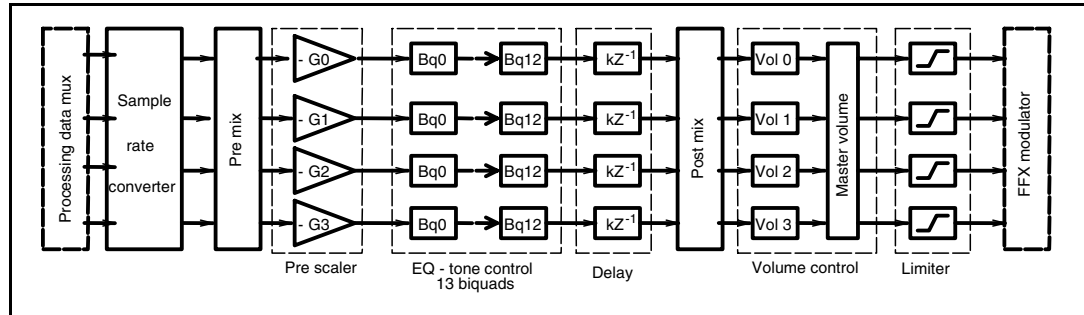

Left and right channels coming from the two serial audio interfaces and ADC (left and right channels) are fed into the selection multiplexer (controlled by register [SRCINSEL on page 128](#)), so that each channel can be connected to any desired processing chain. The four channels are then sample rate converted to the fixed internal sampling rate. Pre mix, EQ/tone processing, programmable delay, post mix, and volume/limiter make up the STA321 signal processing chain.

Figure 14. Processing data multiplexer

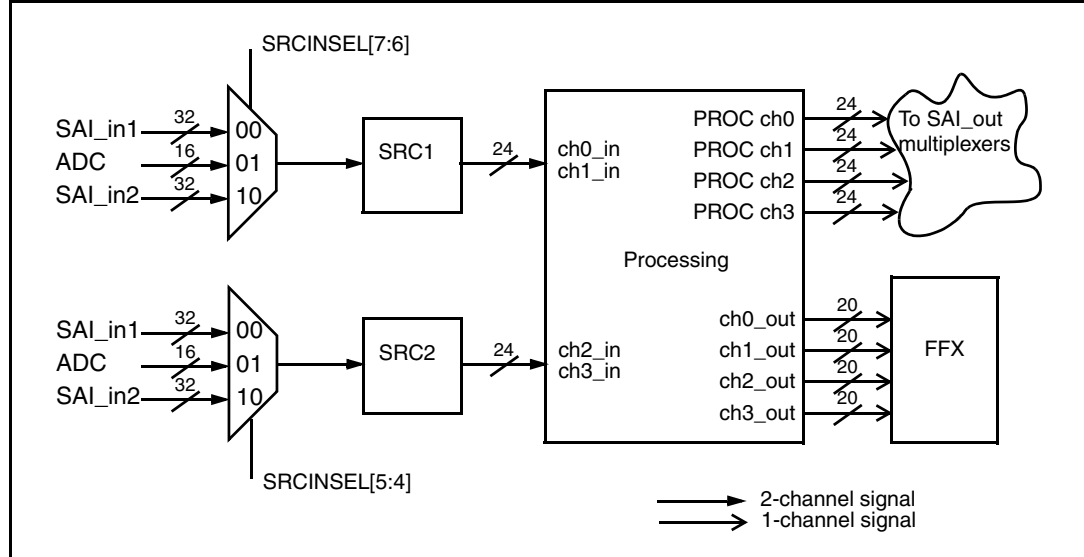
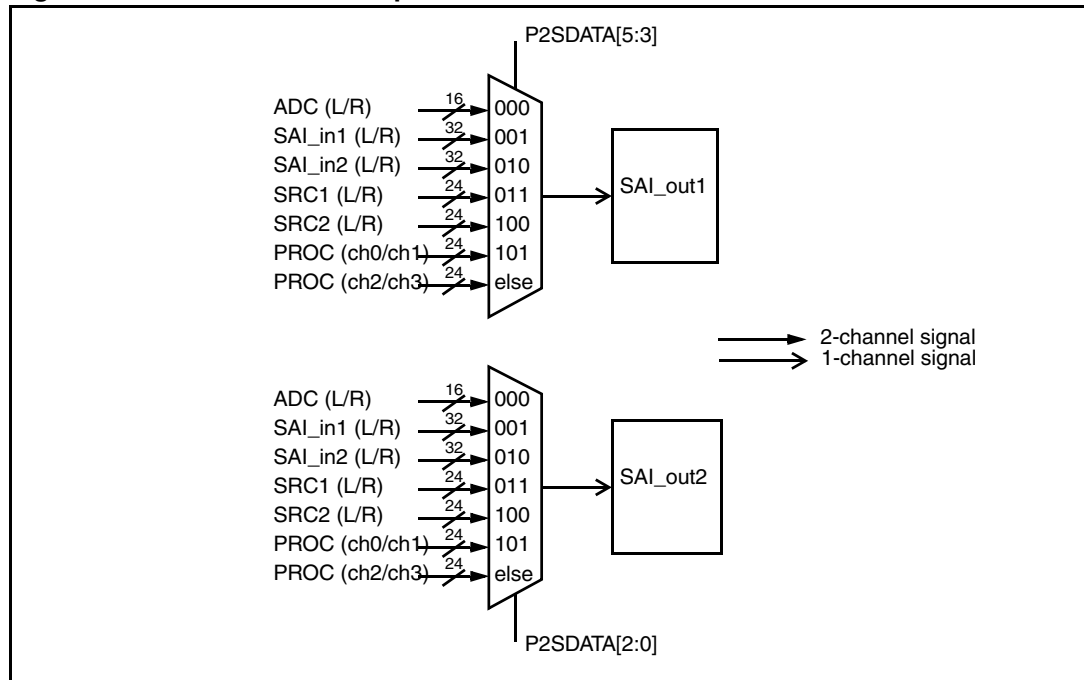

Figure 15. SAI_out data multiplexer



6.2 Sampling rate converter

The sample rate converter (SRC) re samples the input data source in order to send to the processing block an audio stream always with a fixed frequency:

sampling frequency, $f_S = f_{\text{sys_clk}} / 1024$ where $f_{\text{sys_clk}}$ is the system clock frequency.

In all the examples given here, $f_S = 96$ kHz.

Figure 16. Sample rate converter block diagram

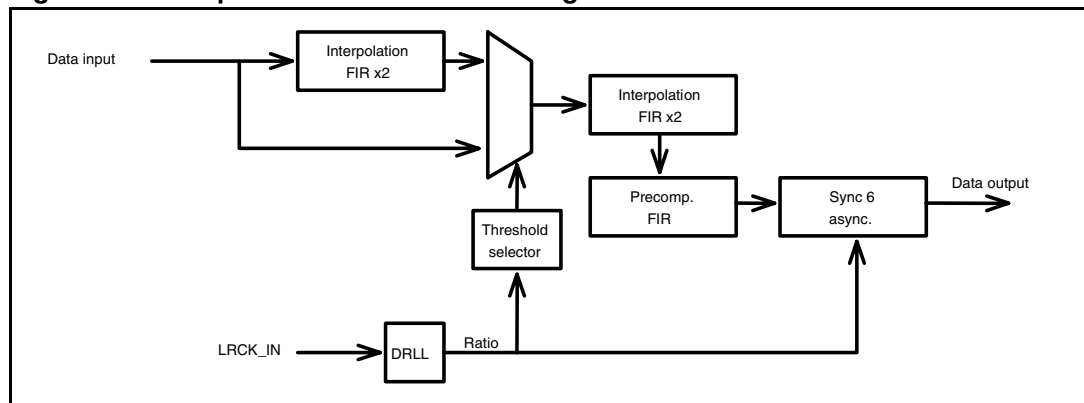

The selection between x2 FIR interpolation and direct input data is made automatically by the threshold selector block. If the input sampling frequency (measured by the DRLL) is higher than the SRC threshold (that is, more than 81 kHz) the direct connection is selected (first filter bypassed), otherwise the first x2 filter is added to the data path.

A 3-kHz hysteresis is fixed around the SRC threshold nominal value in order to prevent unstable oscillations.

6.3 Pre-EQ mix 1 and post-EQ mix

The four-channel data, received from the sample rate converters, is sent to Mix1 block to produce the four mixed-channel data for processing. All this data can be mapped to any internal processing channel through the appropriate configuration of the RAM memory locations.

Table 19. Channel mapping

| Function | Channel | Memory location (RAM) |
|------------|---------|-----------------------|
| Pre mixer | Ch0 | from 0x00 |
| | Ch1 | from 0x04 |
| | Ch2 | from 0x08 |
| | Ch3 | from 0x0c |
| Post mixer | Ch0 | from 0x118 |
| | Ch1 | from 0x11c |
| | Ch2 | from 0x120 |
| | Ch3 | from 0x124 |

The post-EQ mixer acts in a similar way for the output channels from the processing and directed to the FFX. It is placed after the delay block which provides a full 4-channel input mix on every channel.

Figure 17. Mixers block diagram

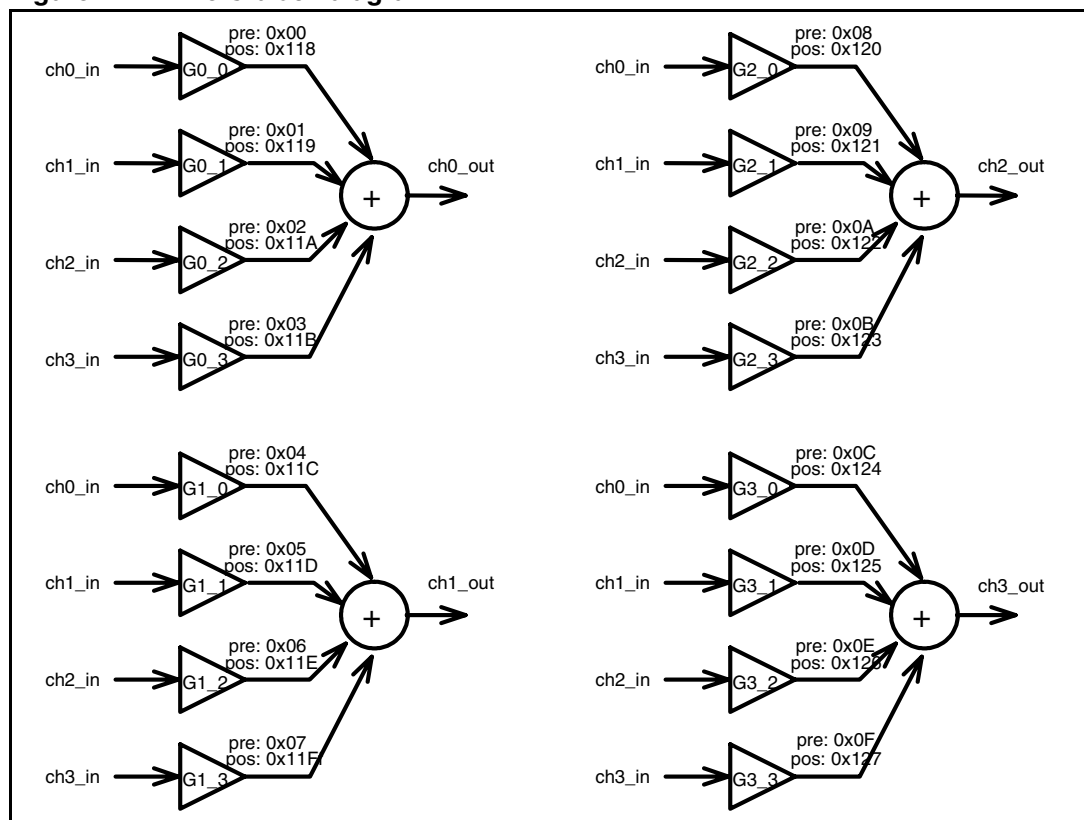

6.3.1 Presets

By default, each mixer output is connected to its corresponding input without any attenuation and without any mixing with the other channels:

$$ch0_out = ch0_in, ch1_out = ch1_in, ch2_out = ch2_in, ch3_out = ch3_in.$$

6.4 Pre scaler

The pre scale block, which precedes the first biquad, could be used to attenuate the input signal when the filters of the processing chain have a gain that could reach the clamping value.

Each channel has a dedicated 24-bit signed multiplier in the range -1 (0x800000) to almost +1 (0x7FFFFFFF).

6.4.1 Presets

By default, all pre-scale factors are set to 0x7FFFFFFF

6.5 Equalization, tone control and effects

Figure 18. EQ/tone block diagram

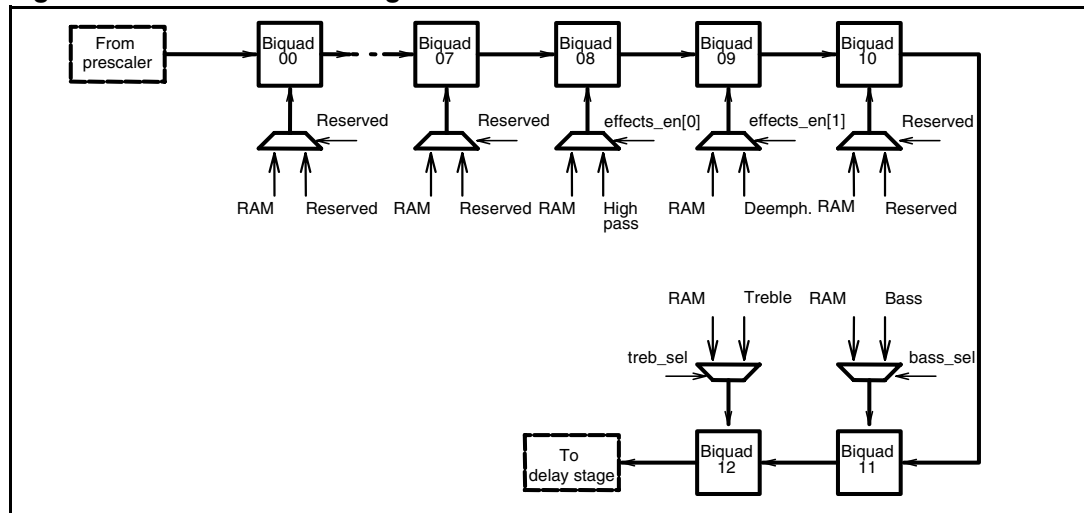

Four channels of input data are fed to the EQ processing block which provides 13 user-programmable biquad filters per channel as shown in [Figure 18](#) above.

A description of the biquad programming is given in [Section 6.14 on page 44](#).

Some filter coefficients are pre-programmed and stored in the non-volatile memory in order to supply particular EQ effects (see [Figure 19](#) and [Table 20 on page 38](#)).

The selection of RAM, ROM bass/treble or ROM effects is made using registers [EFFECTS_EN_CHn on page 109](#) for the effects and [BASS_SELn_R on page 111](#) and [TREB_SELn_R on page 113](#) for the bass/treble. Each biquad can be configured independently.

Figure 19. Biquad coefficient selection

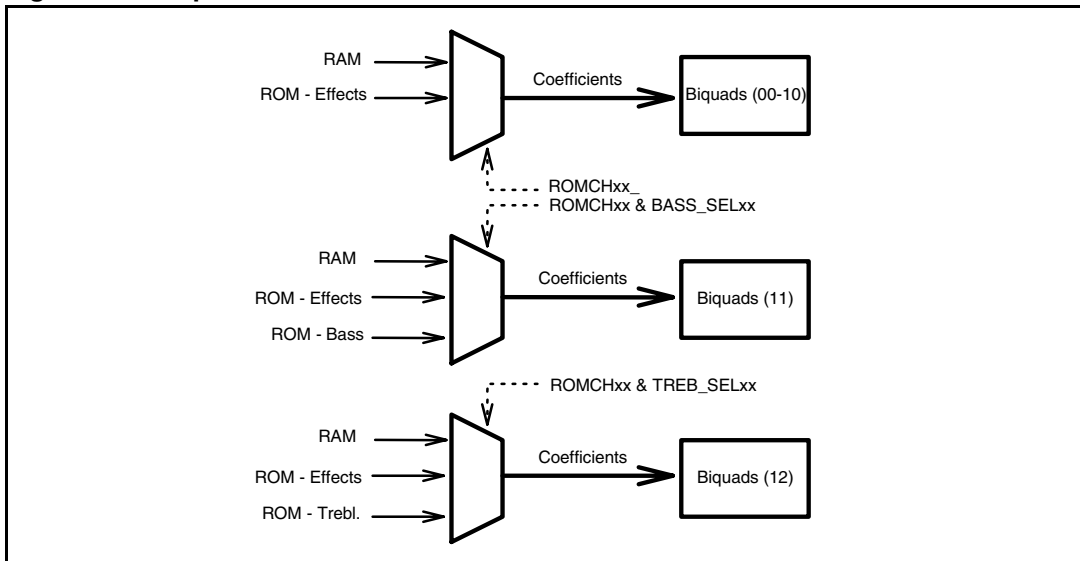

Table 20. EQ control signals

| Signal name | Description | Channel | Register addr |
|---------------|-------------------------------|---------|---------------|
| effects_en[1] | 1: enable deemphasysa filter | Ch0 | 0x71 |
| | | Ch1 | 0x73 |
| | | Ch2 | 0x73 |
| | | Ch3 | 0x77 |
| bass_sel[5] | 1: enable bass tone control | Ch0 | 0x78 |
| | | Ch1 | 0X79 |
| | | Ch2 | 0X7A |
| | | Ch3 | 0X7B |
| treb_sel[5] | 1: enable treble tone control | Ch0 | 0X7C |
| | | Ch1 | 0X7D |
| | | Ch2 | 0X7E |
| | | Ch3 | 0X7F |

6.6 Biquads

The biquads are based on the following equation and is shown diagrammatically in *Figure 20*.

$$Y[n] = b_0 * X[n] + b_1 * X[n-1] + b_2 * X[n-2] - a_1 * Y[n-1] - a_2 * Y[n-2]$$

where $Y[n]$ represents the output and $X[n]$ represents the input. Fractional multipliers are 24-bit signed with coefficient values in the range -1 (0xFFFFF) to +1 (0x7FFFF).

Figure 20. Biquad filter

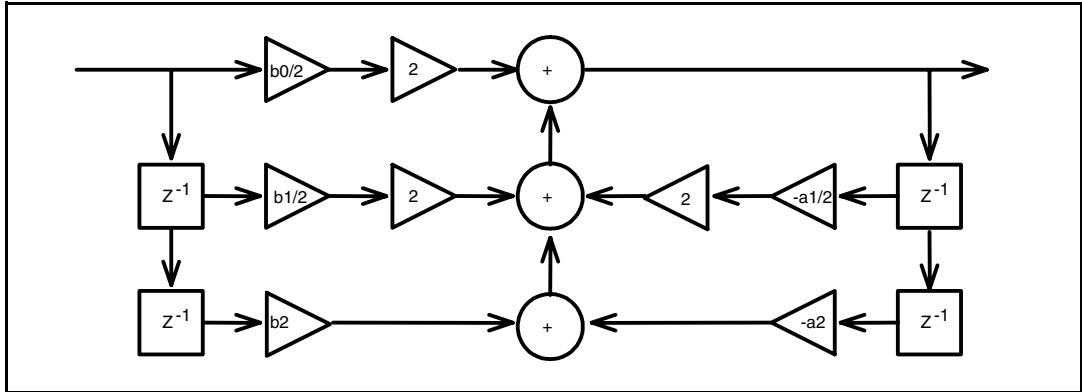

6.6.1 Presets

By default all the biquads values in RAM are set to give a bypass function; in actual fact, the signal passes through unchanged. The coefficients for this are:

$$a_1 / 2 = 0, a_2 / 2 = 0, b_0 / 2 = 0.5 (0x400000), b_1 / 2 = 0, b_2 / 2 = 0.$$

6.7 High-pass filter

The standard high-pass filter is provided by the STA321

Figure 21. High-pass filter frequency response

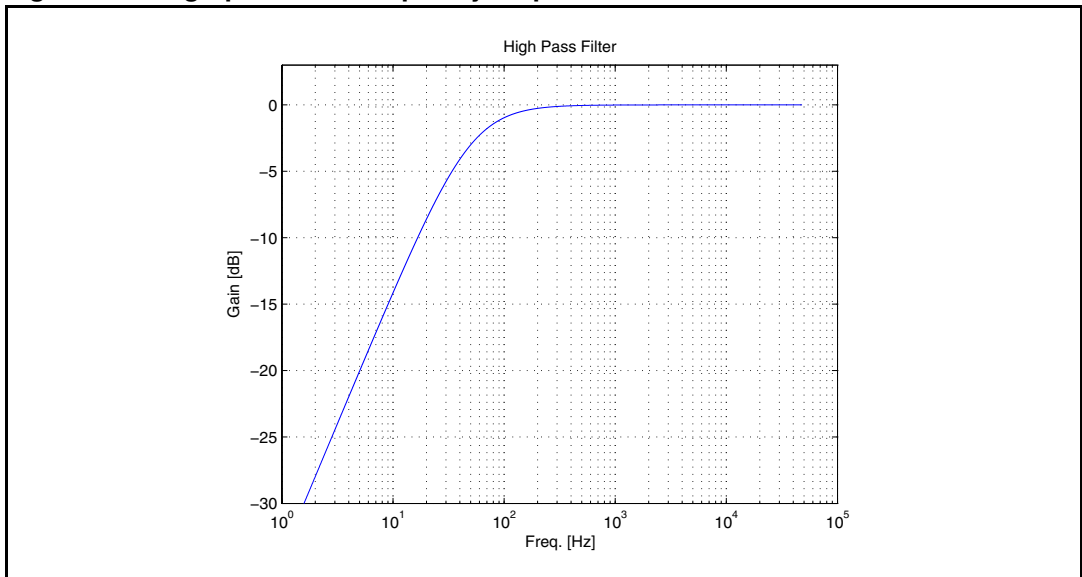

6.8 Deemphasis filter

The standard deemphasis filter is provided by the STA321.

Figure 22. Deemphasis filter frequency response

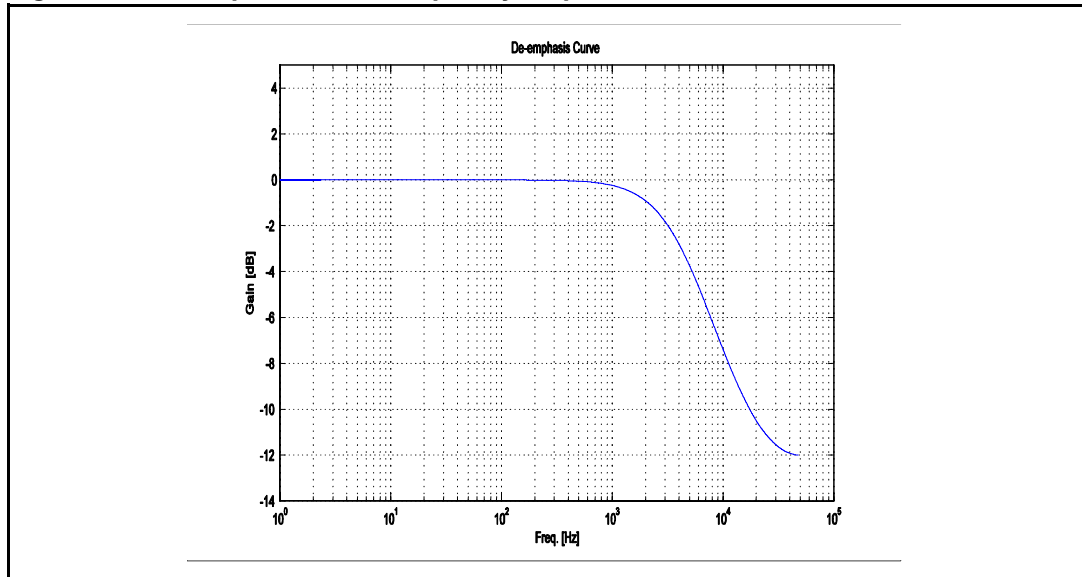

6.9 Bass and treble control

Preset values for the 11th and 12th biquads of every channel are stored in ROM in order to achieve a bass and treble tone control.

They are channel independent and have 24 curves ranging from -12 to +12 dB gain with 1 dB steps. Their selection (and enable) is via registers BASS_SELx_R and TREB_SELx_R where x is the number of the channel to be equalized.

The EQ curve and filter cut-off frequencies are shown in [Figure 23](#) and [Figure 24](#).

With a sampling frequency of 96 kHz (inside the processing block), the cut-off frequencies are 3 kHz for treble curves and 150 Hz for bass curves.

Figure 23. Frequency responses of treble control at 1-dB gain steps

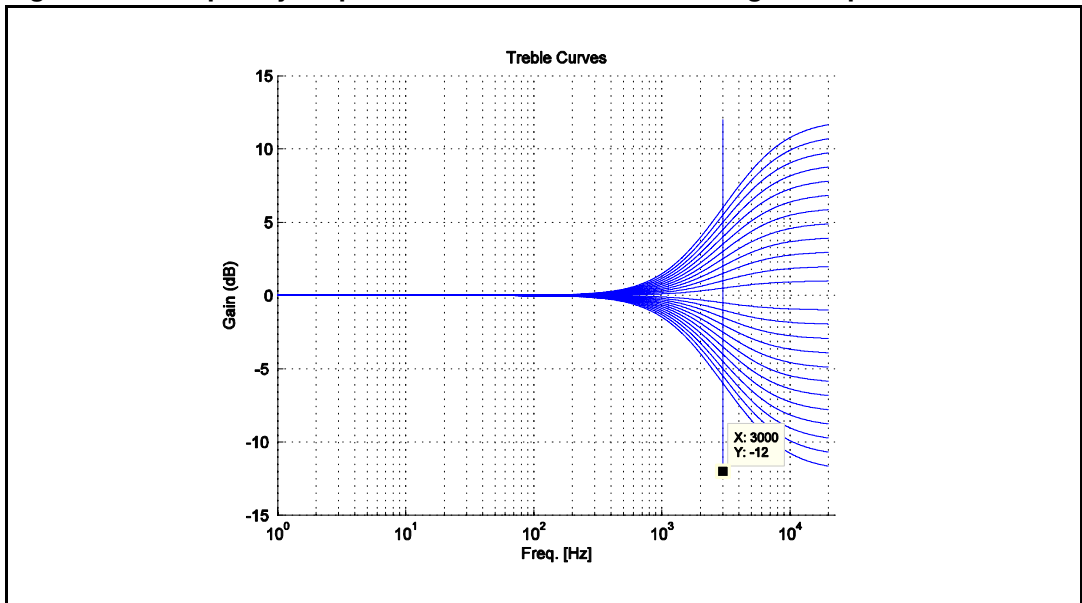
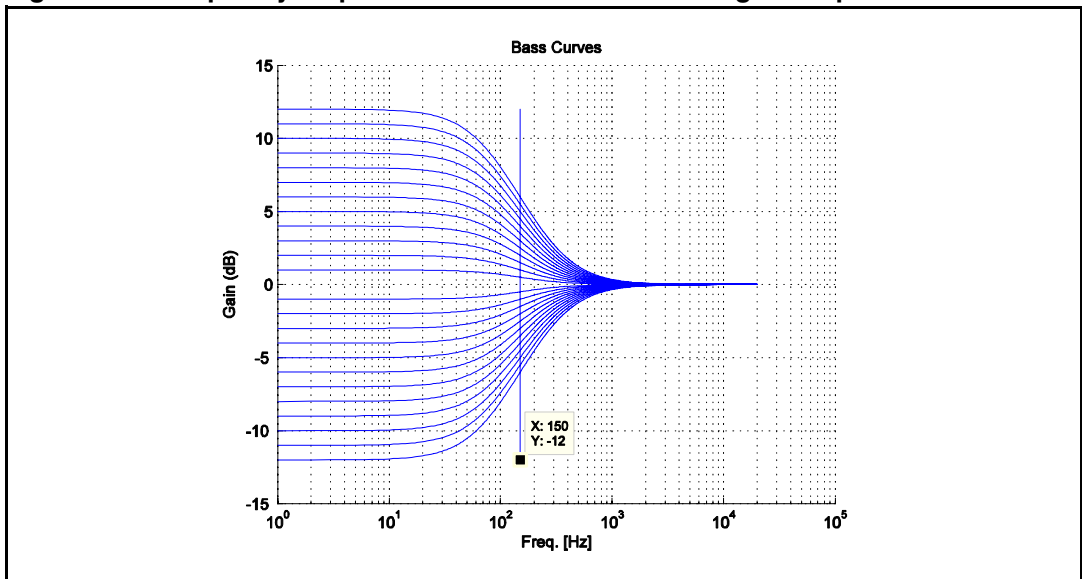

Figure 24. Frequency responses of bass control at 1-dB gain steps



6.9.1 Configuration example

This is an example of the tone control register setup. It is assumed that every peripheral is already configured and working correctly.

[Table 21](#) gives the register values to obtain +12 dB of bass on all channels and -10 dB of treble on channels 0 and 1.

Table 21. Selecting EQ curves

| Register - Address | Programmed value | Description |
|--------------------|------------------|--------------------|
| BASS_SEL0_R | 0x38 | CH0 +12 dB bass |
| BASS_SEL1_R | 0x38 | CH1 +12 dB bass |
| BASS_SEL2_R | 0x38 | CH2 +12 dB bass |
| BASS_SEL3_R | 0x38 | CH3 +12 dB bass |
| TREB_SEL0_R | 0x22 | CH0 -10 dB treble |
| TREB_SEL1_R | 0xx22 | CH1 - 10 dB treble |

6.10 Programmable delay

Every channel, just after the biquads stage, is connected to a dedicated delay block.

The length of the delay is stored in RAM at location 0x128 and can vary from 0 to 35 samples. The corresponding time delay depends on the processing sampling frequency.

6.10.1 Presets

The delay of every channel is set to 0.

6.11 Volume and mute control

The STA321 provides a flexible volume and mute control stage. Using the registers [VOLCH0](#) to [VOLCH3 on page 122](#) it is possible to set the volume for each channel individually from +36 dB to -105 dB with 0.5-dB steps.

There is a master volume control, register [MVOL on page 120](#), as well. The master volume adds an offset to all the individual volume settings.

The mute function offers the possibility to turn off the sound by reducing the volume setting to -127.5 dB. It could be activated in two ways:

- register [FFXCFG0 on page 82](#) provides a dedicated mute control for each channel.
- pin MUTE, driven by an external signal, puts all four channels into mute mode.

Register [VOLCFG on page 120](#) provides some flexibility to set how the mute and volume change procedures are applied. If bit SVOL_ONx is activated the volume of channel x is changed gradually (soft volume or soft mute); using a ramp it starts from the current value and goes down to the target value or to -127.5 dB for mute. The slope of the ramp is set with the value TIM_SVOL which represents how many samples are needed to achieve a 0.5-dB step.

$$t_{\text{STEP}} = 2^{\text{TIM_SVOL}} / f_{\text{S}}$$

The ramp procedure ends when the target volume or mute level is reached. The time for the volume change is calculated as:

$$t_{\text{CHANGE}} = (\text{volume}_{\text{CURRENT}} - \text{volume}_{\text{TARGET}}) / 0.5 * t_{\text{STEP}}$$

If SVOL_ONx is not used, the volume and mute are set instantaneously.

The STA321 also has the possibility to put the FFX into mute in the event of bad input data using register FFXCFG0. If bit BAD_CKS_M is set to 1 the FFX is muted when BICLK and LRCLK do not meet the specifications. If MIS_BICK_M is set to 1 the FFX is muted when BICLK is missing. The mute can be applied gradually or abruptly via bit BAD_IN_M.

6.12 Limiter (clamping)

The saturation stage provides an individual or a global limitation on the output signal amplitude such that if the signal is above the limiting value then it is truncated (clamped).

A 23-bit saturation value made up using registers SATCHxCFG1, SATCHxCFG2 and SATCHxCFG3 can be set for each channel x.

However, if bit 7 of register [SATCH0CFG1 on page 116](#) is set to 1, all the channels take the saturation value of channel 0 and ignore the individual settings.

6.13 FFX channel re-mapping

Figure 25. FFX re-mapping

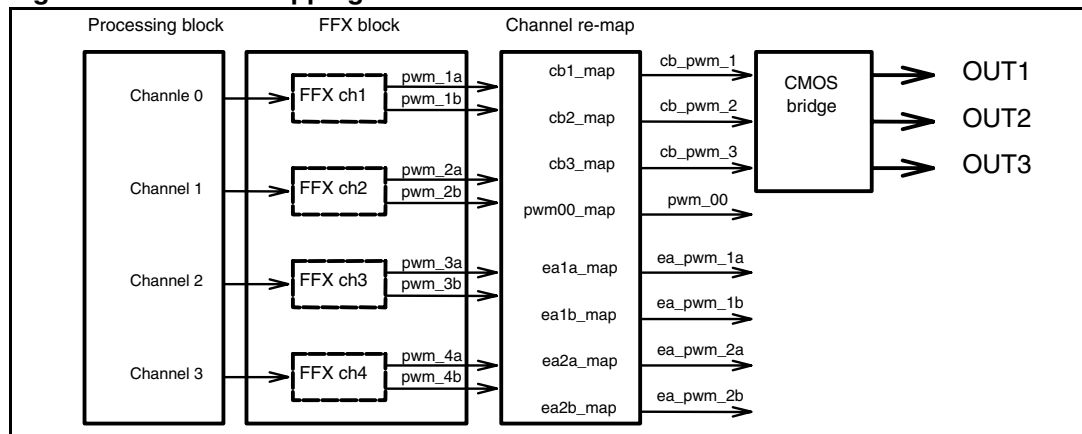

The channels are re-mapped through registers [PWMMAP1](#), [PWMMAP2](#) and [PWMMAP3 on page 86](#). The default configuration routes the channels directly to their respective CB/EA signals:

- pwm_1a -> cb_pwm_1
- pwm_1b -> cb_pwm_2
- pwm_2a -> cb_pwm_3
- pwm_2b -> pwm_00 (PWM00)
- pwm_3a -> ea_pwm_1 (EAPWM1)
- pwm_3b -> ea_pwm_2 (EAPWM2)
- pwm_4a -> ea_pwm_3 (EAPWM3)
- pwm_4b -> ea_pwm_4 (EAPWM4)

6.14 Memory programming

Table 22 on page 47 shows the RAM mapping for the programmable functions in the signal processing stage. Changing or reading this data is done through the I²C interface in either single-word mode or in multi-word mode. Register *PROCCTRL* on page 107 sets the desired mode and whether to read or write:

- 1-word mode:
this is for write only; the address of the memory location must be specified in registers *START_ADDR2* and *START_ADDR1* on page 108 and the value of the parameter must be written into registers *I2CB0_TOP*, *I2CB0_MID* and *I2CB0_BOT* on page 102.
- 5-word mode:
in this case it is possible to write/read 5 contiguous locations. Only the address of the first one must be specified in registers *START_ADDR1-2*, all the others are generated automatically. The values of the parameters must be placed in (or taken from) registers *I2CB0_TOP-BOT*, *I2CB1_TOP-BOT*, *I2CB2_TOP-BOT*, *I2CA1_TOP-BOT*, *I2CA2_TOP-BOT*.

The 5-word mode is particularly useful during the biquad programming when a set of five coefficients needs to be updated. Not only is it more efficient to change all of them at the same time but it avoids the generation of possible unpleasant acoustical side-effects.

The following sections explain how to implement this programming using the I²C interface.

6.14.1 Writing one coefficient/location to RAM

- Write RAM address to registers *START_ADDR2* and *START_ADDR1*
- (b0) Write 8 MSBs of coefficient in register *I2CB0_TOP*
- Write 8 middle bits of coefficient in register *I2CB0_MID*
- Write 8 LSBs of coefficient in register *I2CB0_BOT*
- Write 1 to bit W1 in register *PROCCTRL*.

Figure 26. Writing RAM location

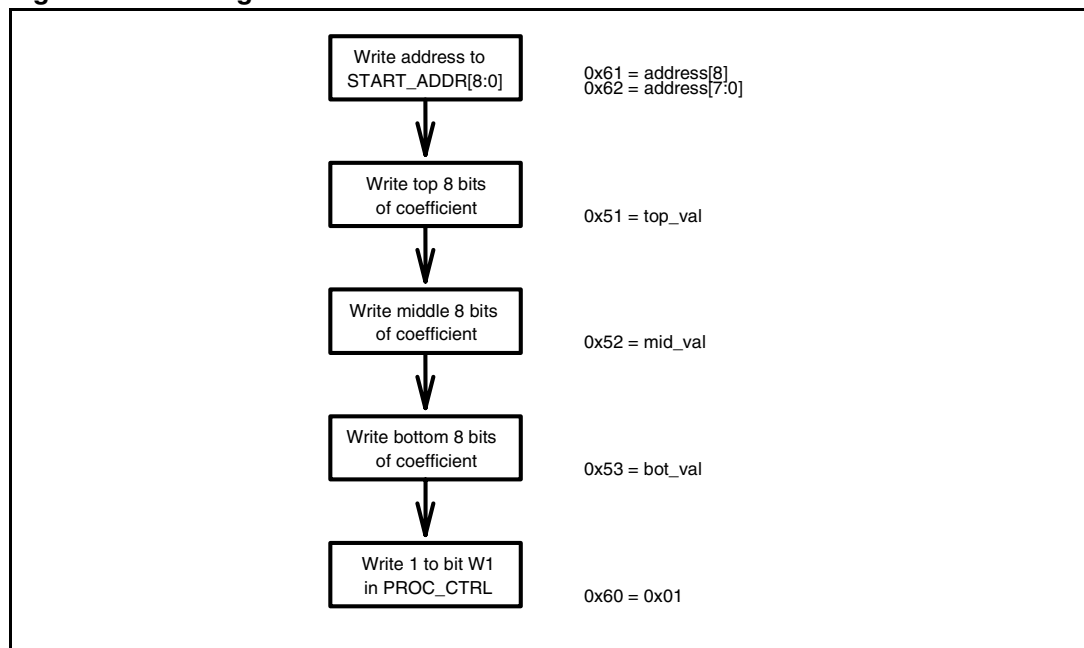

6.14.2 Writing a set of five coefficients/locations to RAM

- Write RAM address of b0 to registers *START_ADDR2* and *START_ADDR1*
- (b0) Write 8 MSBs of coefficient in register *I2CB0_TOP*
- Write 8 middle bits of coefficient in register *I2CB0_MID*
- Write 8 LSBs of coefficient in register *I2CB0_BOT*
- (b1) Write 8 MSBs of coefficient in register *I2CB1_TOP*
- Write 8 middle bits of coefficient in register *I2CB1_MID*
- Write 8 LSBs of coefficient in register *I2CB1_BOT*
- (b2) Write 8 MSBs of coefficient in register *I2CB2_TOP*
- Write 8 middle bits of coefficient in register *I2CB2_MID*
- Write 8 LSBs of coefficient in register *I2CB2_BOT*
- (a1) Write 8 MSBs of coefficient in register *I2CA1_TOP*
- Write 8 middle bits of coefficient in register *I2CA1_MID*
- Write 8 LSBs of coefficient in register *I2CA1_BOT*
- (a2) Write 8 MSBs of coefficient in register *I2CA2_TOP*
- Write 8 middle bits of coefficient in register *I2CA2_MID*
- Write 8 LSBs of coefficient in register *I2CA2_BOT*
- Write 1 to bit WA in register *PROCCTRL*.

Figure 27. Writing five contiguous RAM locations

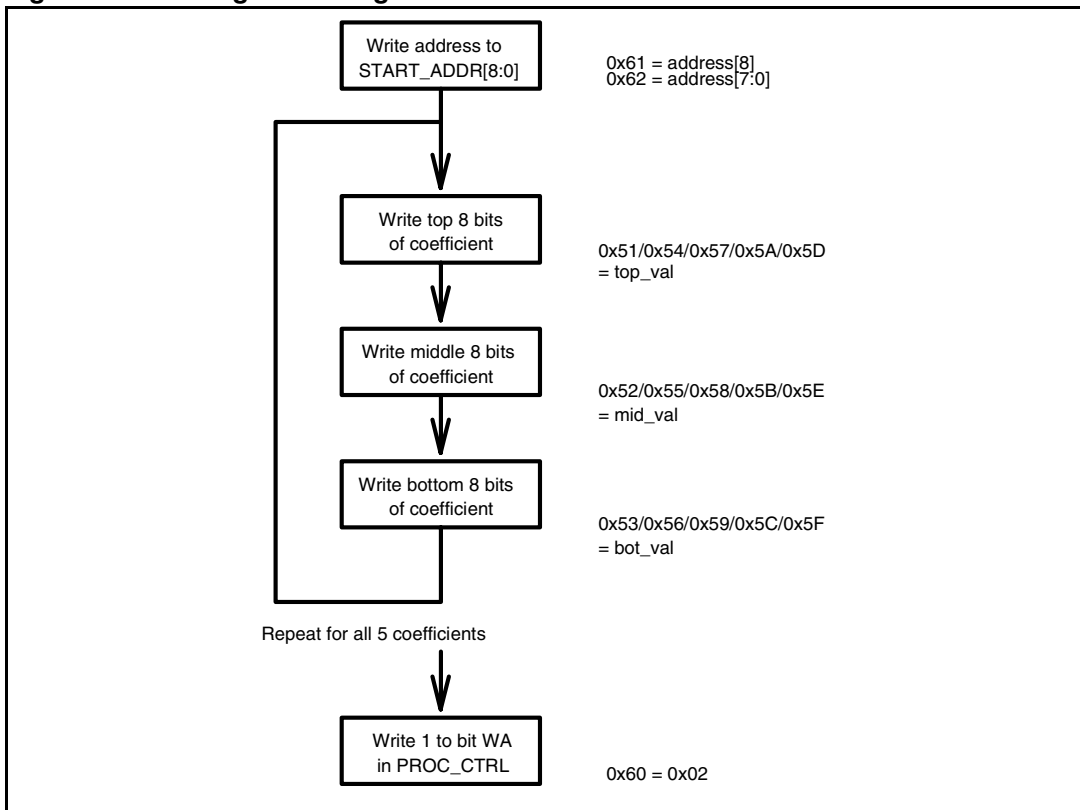

6.14.3 Reading a set of five coefficients/locations from RAM

- Write RAM address of b0 to registers *START_ADDR2* and *START_ADDR1*
- Write 1 to bit RA in register *PROCCTRL*
- (b0) Read 8 MSBs of coefficient in register *I2CB0_TOP*
- Read 8 middle bits of coefficient in register *I2CB0_MID*
- Read 8 LSBs of coefficient in register *I2CB0_BOT*
- (b1) Read 8 MSBs of coefficient in register *I2CB1_TOP*
- Read 8 middle bits of coefficient in register *I2CB1_MID*
- Read 8 LSBs of coefficient in register *I2CB1_BOT*
- (b2) Read 8 MSBs of coefficient in register *I2CB2_TOP*
- Read 8 middle bits of coefficient in register *I2CB2_MID*
- Read 8 LSBs of coefficient in register *I2CB2_BOT*
- (a1) Read 8 MSBs of coefficient in register *I2CA1_TOP*
- Read 8 middle bits of coefficient in register *I2CA1_MID*
- Read 8 LSBs of coefficient in register *I2CA1_BOT*
- (a2) Read 8 MSBs of coefficient in register *I2CA2_TOP*
- Read 8 middle bits of coefficient in register *I2CA2_MID*
- Read 8 LSBs of coefficient in register *I2CA2_BOT*

Figure 28. Reading five contiguous RAM locations

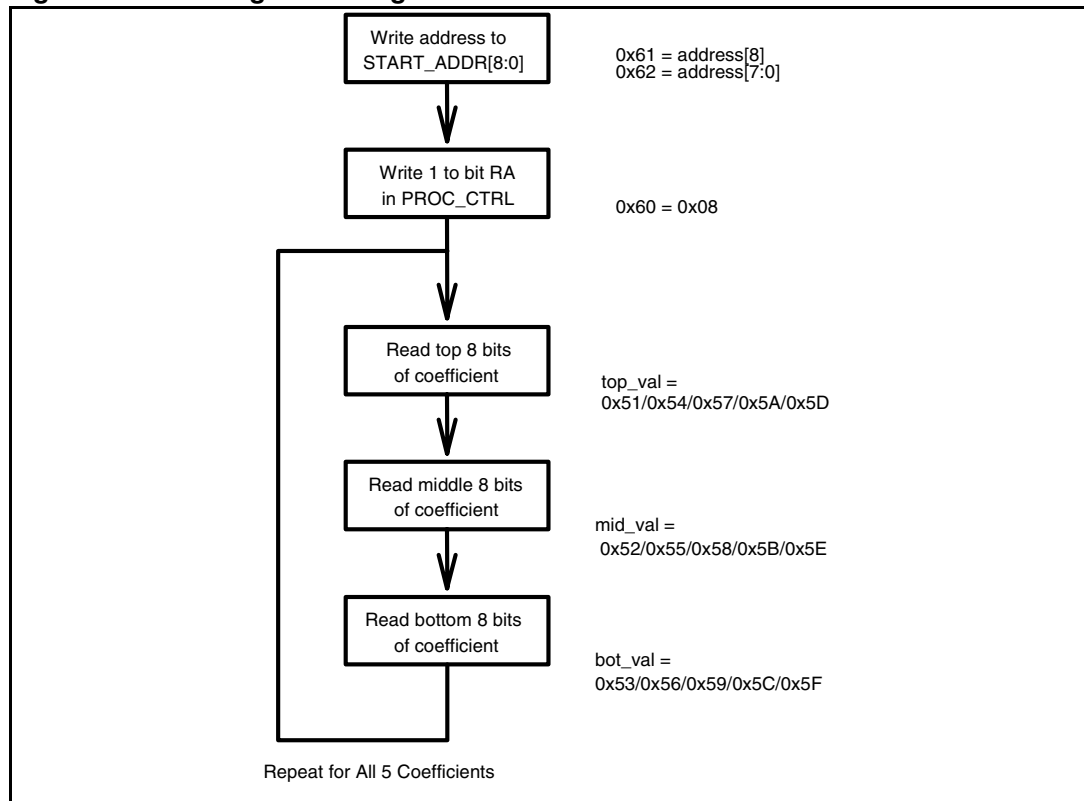

6.14.4 RAM mapping

Table 22. RAM mapping for processing stage

| Addr | Descr. | Default | Block | Addr | Descr. | Default | Block |
|-------|--------|------------|--------------|-------|--------|----------|--------------|
| 0x000 | ch0i | 0x7FFFFFFF | Pre mix: ch0 | 0x021 | #2 a2 | 0x000000 | (Ch0-biquad) |
| 0x001 | ch1i | 0x000000 | | 0x022 | #2 a1 | 0x000000 | |
| 0x002 | ch2i | 0x000000 | | 0x023 | #3 b0 | 0x400000 | |
| 0x003 | ch3i | 0x000000 | | 0x024 | #3 b1 | 0x000000 | |
| 0x004 | ch0i | 0x000000 | Pre mix: ch1 | 0x025 | #3 b2 | 0x000000 | |
| 0x005 | ch1i | 0x7FFFFFFF | | 0x026 | #3 a2 | 0x000000 | |
| 0x006 | ch2i | 0x000000 | | 0x027 | #3 a1 | 0x000000 | |
| 0x007 | ch3i | 0x000000 | | 0x028 | #3 b0 | 0x400000 | |
| 0x008 | ch0i | 0x000000 | Pre mix: ch2 | 0x029 | #4 b1 | 0x000000 | |
| 0x009 | ch1i | 0x000000 | | 0x02A | #4 b2 | 0x000000 | |
| 0x00A | ch2i | 0x7FFFFFFF | | 0x02B | #4 a2 | 0x000000 | |
| 0x00B | ch3i | 0x000000 | | 0x02C | #4 a1 | 0x000000 | |
| 0x00C | ch0i | 0x000000 | Pre mix: ch3 | 0x02D | #5 b0 | 0x400000 | |
| 0x00D | ch1i | 0x000000 | | 0x02E | #5 b1 | 0x000000 | |
| 0x00E | ch2i | 0x000000 | | 0x02F | #5 b2 | 0x000000 | |
| 0x00F | ch3i | 0x7FFFFFFF | | 0x030 | #5 a2 | 0x000000 | |
| 0x010 | ch0 | 0x7FFFFFFF | Pre scaler | 0x031 | #5 a1 | 0x000000 | |
| 0x011 | ch1 | 0x7FFFFFFF | | 0x032 | #6 b0 | 0x400000 | |
| 0x012 | ch2 | 0x7FFFFFFF | | 0x033 | #6 b1 | 0x000000 | |
| 0x013 | ch3 | 0x7FFFFFFF | | 0x034 | #6 b2 | 0x000000 | |
| 0x014 | #0 b0 | 0x400000 | Ch0-biquad | 0x035 | #6 a2 | 0x000000 | |
| 0x015 | #0 b1 | 0x000000 | | 0x036 | #6 a1 | 0x000000 | |
| 0x016 | #0 b2 | 0x000000 | | 0x037 | #7 b0 | 0x400000 | |
| 0x017 | #0 a2 | 0x000000 | | 0x038 | #7 b1 | 0x000000 | |
| 0x018 | #0 a1 | 0x000000 | | 0x039 | #7 b2 | 0x000000 | |
| 0x019 | #1 b0 | 0x400000 | | 0x03A | #7 a2 | 0x000000 | |
| 0x01A | #1 b1 | 0x000000 | | 0x03B | #7 a1 | 0x000000 | |
| 0x01B | #1 b2 | 0x000000 | | 0x03C | #8 b0 | 0x400000 | |
| 0x01C | #1 a2 | 0x000000 | | 0x03D | #8 b1 | 0x000000 | |
| 0x01D | #1 a1 | 0x000000 | | 0x03E | #8 b2 | 0x000000 | |
| 0x01E | #2 b0 | 0x400000 | | 0x03F | #8 a2 | 0x000000 | |
| 0x01F | #2 b1 | 0x000000 | | 0x040 | #8 a1 | 0x000000 | |
| 0x020 | #2 b2 | 0x000000 | | 0x041 | #9 b0 | 0x400000 | |

Table 22. RAM mapping for processing stage (continued)

| Addr | Descr. | Default | Block | Addr | Descr. | Default | Block |
|-------|--------|----------|--------------|--------|----------|----------|-------|
| 0x042 | #9 b1 | 0x000000 | (Ch0-biquad) | 0x065 | #3 b1 | 0x000000 | |
| 0x043 | #9 b2 | 0x000000 | | 0x066 | #3 b2 | 0x000000 | |
| 0x044 | #9 a2 | 0x000000 | | 0x067 | #3 a2 | 0x000000 | |
| 0x045 | #9 a1 | 0x000000 | | 0x068 | #3 a1 | 0x000000 | |
| 0x046 | #10 b0 | 0x400000 | | 0x069 | #3 b0 | 0x400000 | |
| 0x047 | #10 b1 | 0x000000 | | 0x06A | #4 b1 | 0x000000 | |
| 0x048 | #10 b2 | 0x000000 | | 0x06B | #4 b2 | 0x000000 | |
| 0x049 | #10 a2 | 0x000000 | | 0x06C | #4 a2 | 0x000000 | |
| 0x04A | #10 a1 | 0x000000 | | 0x06D | #4 a1 | 0x000000 | |
| 0x04B | #11 b0 | 0x400000 | | 0x06E | #5 b0 | 0x400000 | |
| 0x04C | #11 b1 | 0x000000 | | 0x06F | #5 b1 | 0x000000 | |
| 0x04D | #11 b2 | 0x000000 | | 0x070 | #5 b2 | 0x000000 | |
| 0x04E | #11 a2 | 0x000000 | | 0x071 | #5 a2 | 0x000000 | |
| 0x04F | #11 a1 | 0x000000 | | 0x072 | #5 a1 | 0x000000 | |
| 0x050 | #12 b0 | 0x400000 | | 0x073 | #6 b0 | 0x400000 | |
| 0x051 | #12 b1 | 0x000000 | | 0x074 | #6 b1 | 0x000000 | |
| 0x052 | #12 b2 | 0x000000 | | 0x075 | #6 b2 | 0x000000 | |
| 0x053 | #12 a2 | 0x000000 | | 0x076 | #6 a2 | 0x000000 | |
| 0x054 | #12 a1 | 0x000000 | | 0x077 | #6 a1 | 0x000000 | |
| 0x055 | #0 b0 | 0x400000 | | 0x078 | #7 b0 | 0x400000 | |
| 0x056 | #0 b1 | 0x000000 | 0x079 | #7 b1 | 0x000000 | | |
| 0x057 | #0 b2 | 0x000000 | 0x07A | #7 b2 | 0x000000 | | |
| 0x058 | #0 a2 | 0x000000 | 0x07B | #7 a2 | 0x000000 | | |
| 0x059 | #0 a1 | 0x000000 | 0x07C | #7 a1 | 0x000000 | | |
| 0x05A | #1 b0 | 0x400000 | 0x07D | #8 b0 | 0x400000 | | |
| 0x05B | #1 b1 | 0x000000 | 0x07E | #8 b1 | 0x000000 | | |
| 0x05C | #1 b2 | 0x000000 | 0x07F | #8 b2 | 0x000000 | | |
| 0x05D | #1 a2 | 0x000000 | 0x080 | #8 a2 | 0x000000 | | |
| 0x05E | #1 a1 | 0x000000 | 0x081 | #8 a1 | 0x000000 | | |
| 0x05F | #2 b0 | 0x400000 | 0x082 | #9 b0 | 0x400000 | | |
| 0x060 | #2 b1 | 0x000000 | 0x083 | #9 b1 | 0x000000 | | |
| 0x061 | #2 b2 | 0x000000 | 0x084 | #9 b2 | 0x000000 | | |
| 0x062 | #2 a2 | 0x000000 | 0x085 | #9 a2 | 0x000000 | | |
| 0x063 | #2 a1 | 0x000000 | 0x086 | #9 a1 | 0x000000 | | |
| 0x064 | #3 b0 | 0x400000 | 0x087 | #10 b0 | 0x400000 | | |

Table 22. RAM mapping for processing stage (continued)

| Addr | Descr. | Default | Block | Addr | Descr. | Default | Block |
|-------|--------|----------|--------------|------------|----------|----------|--------------|
| 0x088 | #10 b1 | 0x000000 | (Ch1-biquad) | 0x0AB | #4 b1 | 0x000000 | (Ch2-biquad) |
| 0x089 | #10 b2 | 0x000000 | | 0x0AC | #4 b2 | 0x000000 | |
| 0x08A | #10 a2 | 0x000000 | | 0x0AD | #4 a2 | 0x000000 | |
| 0x08B | #10 a1 | 0x000000 | | 0x0AE | #4 a1 | 0x000000 | |
| 0x08C | #11 b0 | 0x400000 | | 0x0AF | #5 b0 | 0x400000 | |
| 0x08D | #11 b1 | 0x000000 | | 0x0B0 | #5 b1 | 0x000000 | |
| 0x08E | #11 b2 | 0x000000 | | 0x0B1 | #5 b2 | 0x000000 | |
| 0x08F | #11 a2 | 0x000000 | | 0x0B2 | #5 a2 | 0x000000 | |
| 0x090 | #11 a1 | 0x000000 | | 0x0B3 | #5 a1 | 0x000000 | |
| 0x091 | #12 b0 | 0x400000 | | 0x0B4 | #6 b0 | 0x400000 | |
| 0x092 | #12 b1 | 0x000000 | | 0x0B5 | #6 b1 | 0x000000 | |
| 0x093 | #12 b2 | 0x000000 | | 0x0B6 | #6 b2 | 0x000000 | |
| 0x094 | #12 a2 | 0x000000 | | 0x0B7 | #6 a2 | 0x000000 | |
| 0x095 | #12 a1 | 0x000000 | | 0x0B8 | #6 a1 | 0x000000 | |
| 0x096 | #0 b0 | 0x400000 | | Ch2-biquad | 0x0B9 | #7 b0 | |
| 0x097 | #0 b1 | 0x000000 | 0x0BA | | #7 b1 | 0x000000 | |
| 0x098 | #0 b2 | 0x000000 | 0x0BB | | #7 b2 | 0x000000 | |
| 0x099 | #0 a2 | 0x000000 | 0x0BC | | #7 a2 | 0x000000 | |
| 0x09A | #0 a1 | 0x000000 | 0x0BD | | #7 a1 | 0x000000 | |
| 0x09B | #1 b0 | 0x400000 | 0x0BE | | #8 b0 | 0x400000 | |
| 0x09C | #1 b1 | 0x000000 | 0x0BF | | #8 b1 | 0x000000 | |
| 0x09D | #1 b2 | 0x000000 | 0x0C0 | | #8 b2 | 0x000000 | |
| 0x09E | #1 a2 | 0x000000 | 0x0C1 | | #8 a2 | 0x000000 | |
| 0x09F | #1 a1 | 0x000000 | 0x0C2 | | #8 a1 | 0x000000 | |
| 0x0A0 | #2 b0 | 0x400000 | 0x0C3 | | #9 b0 | 0x400000 | |
| 0x0A1 | #2 b1 | 0x000000 | 0x0C4 | | #9 b1 | 0x000000 | |
| 0x0A2 | #2 b2 | 0x000000 | 0x0C5 | | #9 b2 | 0x000000 | |
| 0x0A3 | #2 a2 | 0x000000 | 0x0C6 | | #9 a2 | 0x000000 | |
| 0x0A4 | #2 a1 | 0x000000 | 0x0C7 | | #9 a1 | 0x000000 | |
| 0x0A5 | #3 b0 | 0x400000 | 0x0C8 | #10 b0 | 0x400000 | | |
| 0x0A6 | #3 b1 | 0x000000 | 0x0C9 | #10 b1 | 0x000000 | | |
| 0x0A7 | #3 b2 | 0x000000 | 0x0CA | #10 b2 | 0x000000 | | |
| 0x0A8 | #3 a2 | 0x000000 | 0x0CB | #10 a2 | 0x000000 | | |
| 0x0A9 | #3 a1 | 0x000000 | 0x0CC | #10 a1 | 0x000000 | | |
| 0x0AA | #3 b0 | 0x400000 | 0x0CD | #11 b0 | 0x400000 | | |

Table 22. RAM mapping for processing stage (continued)

| Addr | Descr. | Default | Block | Addr | Descr. | Default | Block |
|-------|--------|----------|--------------|--------|----------|----------|--------------|
| 0x0CE | #11 b1 | 0x000000 | (Ch2-biquad) | 0x0F1 | #5 b1 | 0x000000 | (Ch3-biquad) |
| 0x0CF | #11 b2 | 0x000000 | | 0x0F2 | #5 b2 | 0x000000 | |
| 0x0D0 | #11 a2 | 0x000000 | | 0x0F3 | #5 a2 | 0x000000 | |
| 0x0D1 | #11 a1 | 0x000000 | | 0x0F4 | #5 a1 | 0x000000 | |
| 0x0D2 | #12 b0 | 0x400000 | | 0x0F5 | #6 b0 | 0x400000 | |
| 0x0D3 | #12 b1 | 0x000000 | | 0x0F6 | #6 b1 | 0x000000 | |
| 0x0D4 | #12 b2 | 0x000000 | | 0x0F7 | #6 b2 | 0x000000 | |
| 0x0D5 | #12 a2 | 0x000000 | | 0x0F8 | #6 a2 | 0x000000 | |
| 0x0D6 | #12 a1 | 0x000000 | | 0x0F9 | #6 a1 | 0x000000 | |
| 0x0D7 | #0 b0 | 0x400000 | | 0x0FA | #7 b0 | 0x400000 | |
| 0x0D8 | #0 b1 | 0x000000 | 0x0FB | #7 b1 | 0x000000 | | |
| 0x0D9 | #0 b2 | 0x000000 | 0x0FC | #7 b2 | 0x000000 | | |
| 0x0DA | #0 a2 | 0x000000 | 0x0FD | #7 a2 | 0x000000 | | |
| 0x0DB | #0 a1 | 0x000000 | 0x0FE | #7 a1 | 0x000000 | | |
| 0x0DC | #1 b0 | 0x400000 | 0x0FF | #8 b0 | 0x400000 | | |
| 0x0DD | #1 b1 | 0x000000 | 0x100 | #8 b1 | 0x000000 | | |
| 0x0DE | #1 b2 | 0x000000 | 0x101 | #8 b2 | 0x000000 | | |
| 0x0DF | #1 a2 | 0x000000 | 0x102 | #8 a2 | 0x000000 | | |
| 0x0E0 | #1 a1 | 0x000000 | 0x103 | #8 a1 | 0x000000 | | |
| 0x0E1 | #2 b0 | 0x400000 | 0x104 | #9 b0 | 0x400000 | | |
| 0x0E2 | #2 b1 | 0x000000 | 0x105 | #9 b1 | 0x000000 | | |
| 0x0E3 | #2 b2 | 0x000000 | 0x106 | #9 b2 | 0x000000 | | |
| 0x0E4 | #2 a2 | 0x000000 | 0x107 | #9 a2 | 0x000000 | | |
| 0x0E5 | #2 a1 | 0x000000 | 0x108 | #9 a1 | 0x000000 | | |
| 0x0E6 | #3 b0 | 0x400000 | 0x109 | #10 b0 | 0x400000 | | |
| 0x0E7 | #3 b1 | 0x000000 | 0x10A | #10 b1 | 0x000000 | | |
| 0x0E8 | #3 b2 | 0x000000 | 0x10B | #10 b2 | 0x000000 | | |
| 0x0E9 | #3 a2 | 0x000000 | 0x10C | #10 a2 | 0x000000 | | |
| 0x0EA | #3 a1 | 0x000000 | 0x10D | #10 a1 | 0x000000 | | |
| 0x0EB | #3 b0 | 0x400000 | 0x10E | #11 b0 | 0x400000 | | |
| 0x0EC | #4 b1 | 0x000000 | 0x10F | #11 b1 | 0x000000 | | |
| 0x0ED | #4 b2 | 0x000000 | 0x110 | #11 b2 | 0x000000 | | |
| 0x0EE | #4 a2 | 0x000000 | 0x111 | #11 a2 | 0x000000 | | |
| 0x0EF | #4 a1 | 0x000000 | 0x112 | #11 a1 | 0x000000 | | |
| 0x0F0 | #5 b0 | 0x400000 | 0x113 | #12 b0 | 0x400000 | | |

Table 22. RAM mapping for processing stage (continued)

| Addr | Descr. | Default | Block | Addr | Descr. | Default | Block |
|-------|--------|------------|---------------|-------|--------|------------|---------------|
| 0x114 | #12 b1 | 0x000000 | (Ch3-biquad) | 0x120 | ch0i | 0x000000 | Post mix: ch2 |
| 0x115 | #12 b2 | 0x000000 | | 0x121 | ch1i | 0x000000 | |
| 0x116 | #12 a2 | 0x000000 | | 0x122 | ch2i | 0x7FFFFFFF | |
| 0x117 | #12 a1 | 0x000000 | | 0x123 | ch3i | 0x000000 | |
| 0x118 | ch0i | 0x7FFFFFFF | Post mix: ch0 | 0x124 | ch0i | 0x000000 | Post mix: ch3 |
| 0x119 | ch1i | 0x000000 | | 0x125 | ch1i | 0x000000 | |
| 0x11A | ch2i | 0x000000 | | 0x126 | ch2i | 0x000000 | |
| 0x11B | ch3i | 0x000000 | | 0x127 | ch3i | 0x7FFFFFFF | |
| 0x11C | ch0i | 0x000000 | Post mix: ch1 | 0x128 | delay | 0x000000 | Delay |
| 0x11D | ch1i | 0x7FFFFFFF | | - | - | - | - |
| 0x11E | ch2i | 0x000000 | | - | - | - | - |
| 0x11F | ch3i | 0x000000 | | - | - | - | - |

7 FFX

7.1 Functional description

Figure 29. FFX processing schematic

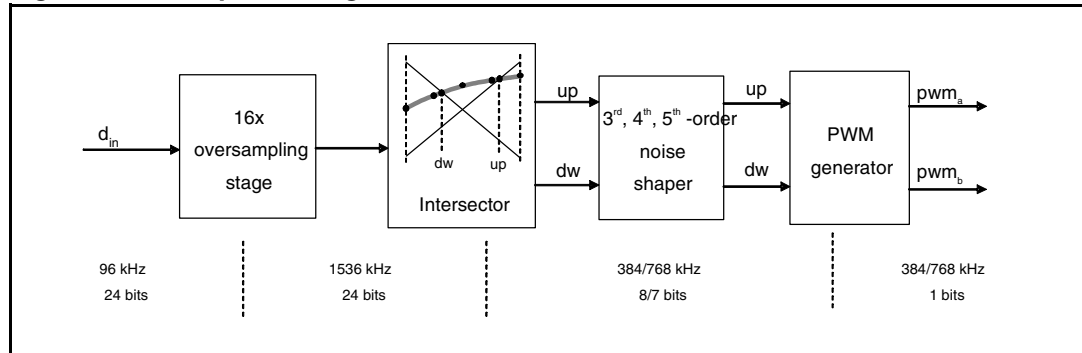

The FFX modulator is a digital low-distortion low-noise PCM-to-PWM converter, based on a pseudo-natural sampling technique, which converts the 4 by 24-bit digital inputs into differential pulse-width modulated outputs at a frequency of either 384 or 768 kHz (selected by register [FFXCFG2](#), bit PWM_FREQ) and with a time resolution of 98.304 MHz. This gives a dynamic range that is approaching 100 dB.

The signal is compared with two different carrier signals (rising and falling sawtooth waveforms at the PWM frequency), to get a double edge modulation and to have the possibility to drive a differential (full bridge) power stage.

The order of the noise shaper can be modified by the user, via register bit [FFXCFG2.NS_ORD](#), depending on the acceptable amount of noise out of the audio band, that is, noise above 20 kHz. The higher the noise shaper order, the better is the SNR but the higher is the out of band noise.

The PWM generator block converts the amplitude quantization into time quantization to generate a PWM signal.

7.2 Modulation schemes

It is possible to use each of the two intersections with up-carrier and down-carrier to force a rising or a falling edge on each of the two PWM outputs (A and B). This flexibility is achieved through programming registers PWMOnCFG1-2 (where n is the number, 1 to 4, of the output) beginning [on page 91](#).

PWM output A can be modulated in one of, or a hybrid of, two basic ways via bits PM_nA:

- with the wave starting from level 0 at the beginning of the period, and rising to level 1 when the audio signal intersects the down-carrier
- with the wave starting from level 1 at the beginning of the period, and falling to level 0 when the audio signal intersects the up-carrier;

PWM output B can be similarly modulated via bits PM_nB:

- with the wave starting from level 1 at the beginning of the period, and falling to level 0 when the audio signal intersects the down-carrier;
- with the wave starting from level 0 at the beginning of the period, and rising to level 1 when the audio signal intersects the up-carrier;

The hybrid mode is the toggling between the two methods of modulation for each PWM period.

Figure 30. PWM modes for outputs A and B

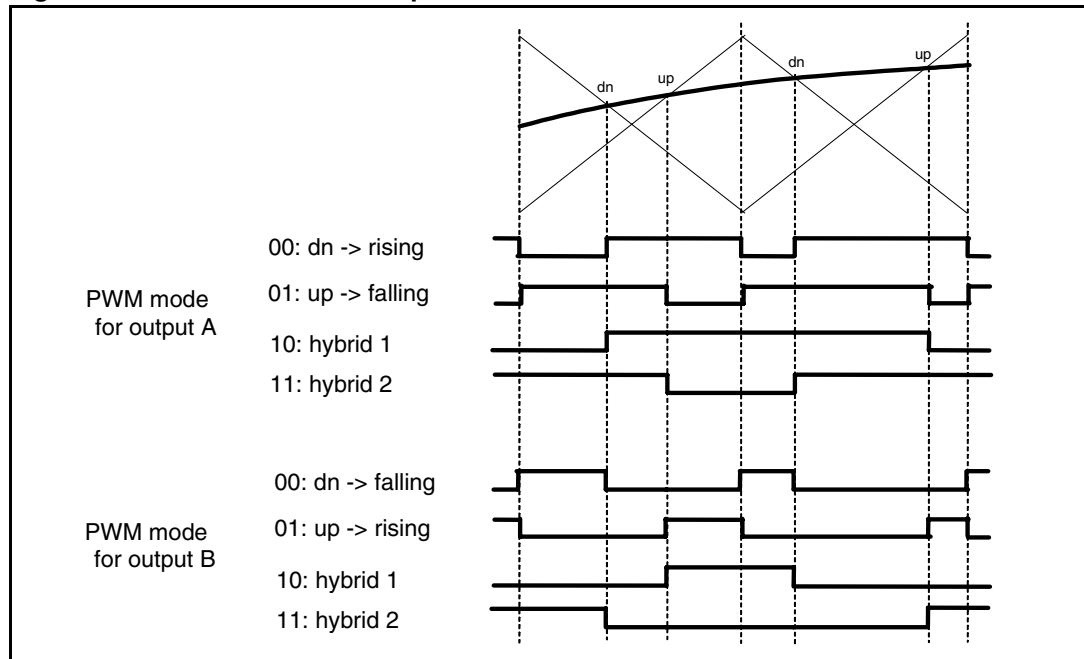

The various single output modulation schemes can be combined together on the two outputs to get the desired differential modulation schemes.

In particular, for the traditional schemes (binary, phase shift), and the new one (new phase shift modulation) the mode bits must be set according to [Table 23](#) below.

Table 23. Modulation type with register programming

| Register bit PWMonCFG1.PM_nA | Register bit PWMonCFG2.PM_nB | Resulting modulation |
|---------------------------------|---------------------------------|----------------------|
| 00 | 00 | binary |
| 01 | 01 | |
| 10 | 10 | phase shift |
| 11 | 11 | |
| 00 | 01 | new phase shift |
| 01 | 00 | |

Figure 31. Modulation waveforms corresponding to [Table 23](#)

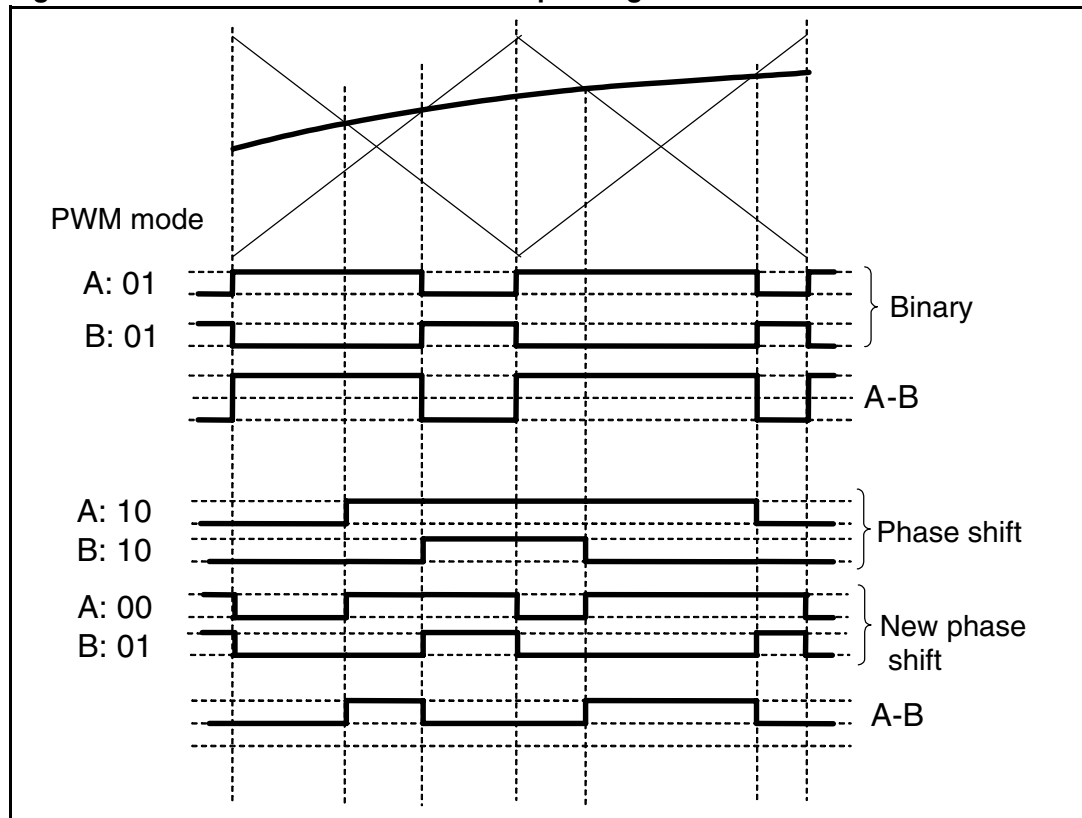

7.3 PWM shift feature

In new phase shift modulation it is possible to shift one output with respect to the other one. This can reduce the noise generated by the simultaneous switching of two or more outputs. The shift is performed through by programming bits PS_nA and PS_nB in registers PWMOnCFG1-2 (where n is the number, 1 to 4, of the output) beginning [on page 91](#).

Figure 32. New phase shift modulation with shift feature

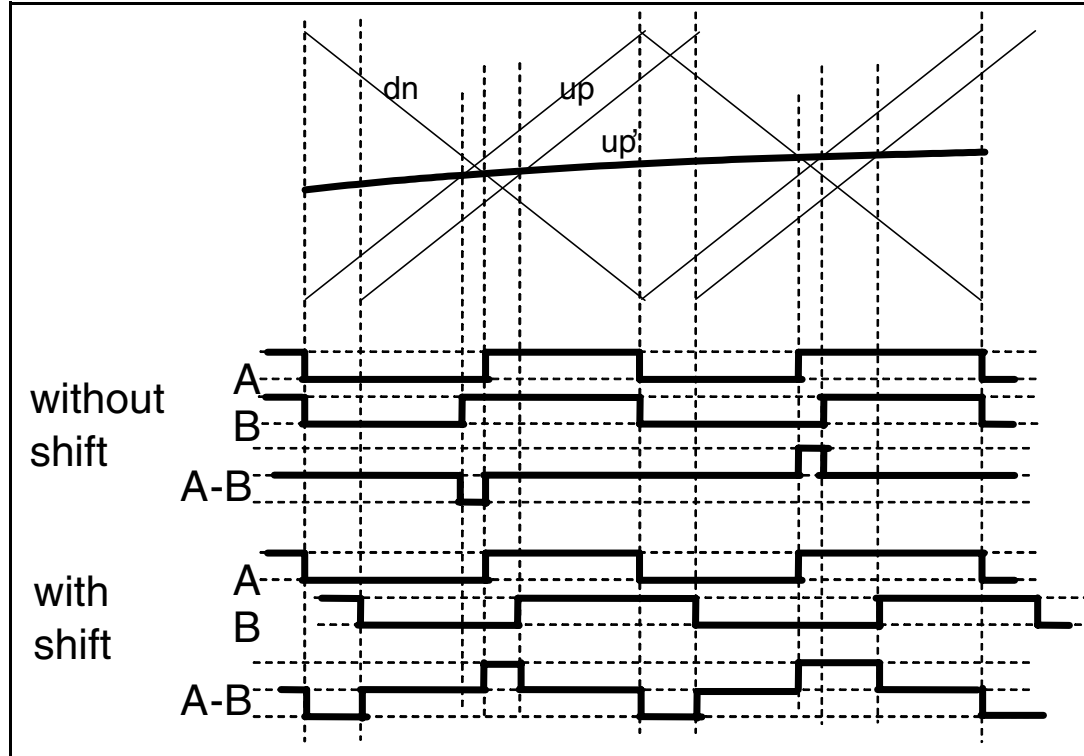

7.4 Ternary mode

The ternary mode feature is also available. It is activated by bits TERNARY_n in registers PWMonCFG0 beginning [on page 91](#) (where n is the number, 1 to 4, of the output).

This feature overrides the PWM mode bits settings PM_nA and PM_nB.

Figure 33. Ternary modulation

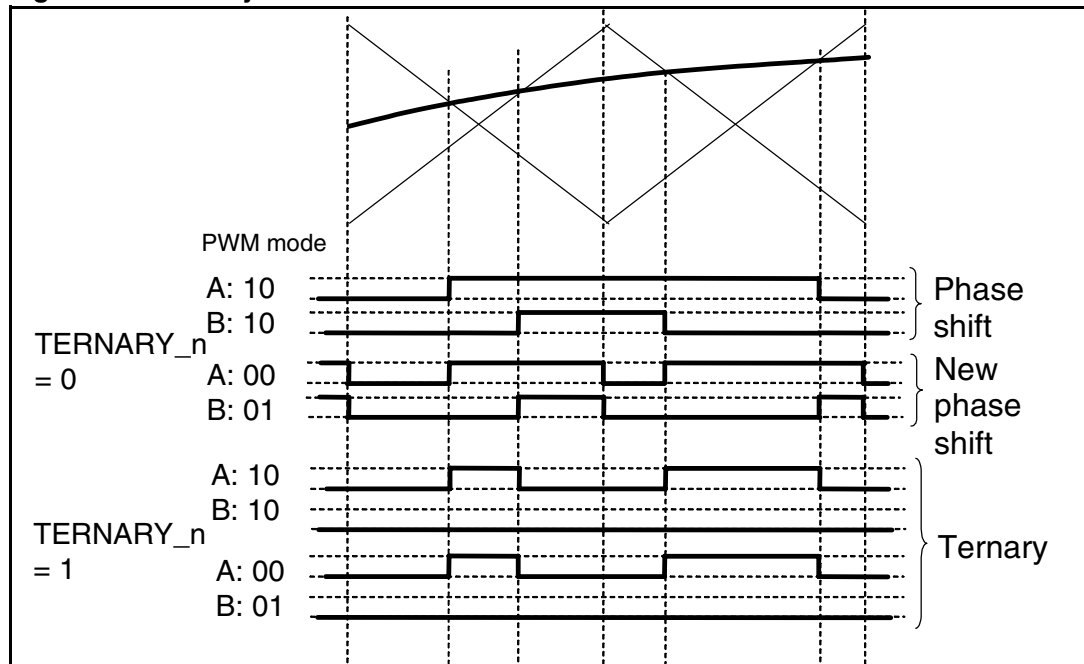

7.5 Minimum pulse limitation

The FFX modulator has a minimum pulse limitation feature which has a double purpose:

- to limit the maximum/minimum duty cycle when the audio signal is near to full scale;
- to have the commutations on the same channel outputs A and B separated by a minimum pulse distance.

The first feature is always enabled.

The second feature is enabled with register bit PWMonCFG0.MP_ZERO_n, where n is the output 1 to 4. It is possible to prevent the commutations on outputs A and B to happen exactly at the same time using bit AZPLS_n. The minimum pulse size is determined by the number of system clock (98.304 MHz) periods programmed in bits MIN_PLS_n[3:0].

7.6 Headphone modulation

The FFX modulator can be used for driving a headphone load with the common terminal available, together with left and right terminals.

In this case it is possible to drive the common terminal with a 50% fixed duty cycle square wave coming from output B of the modulator, by setting bit HALFB_n to 1, and the left and right terminals from the output A of two different channels. For the three outputs used in this way bits PM_{nA} and PM_{nB} can be 00 or 01.

Figure 34. Modulation for headphones

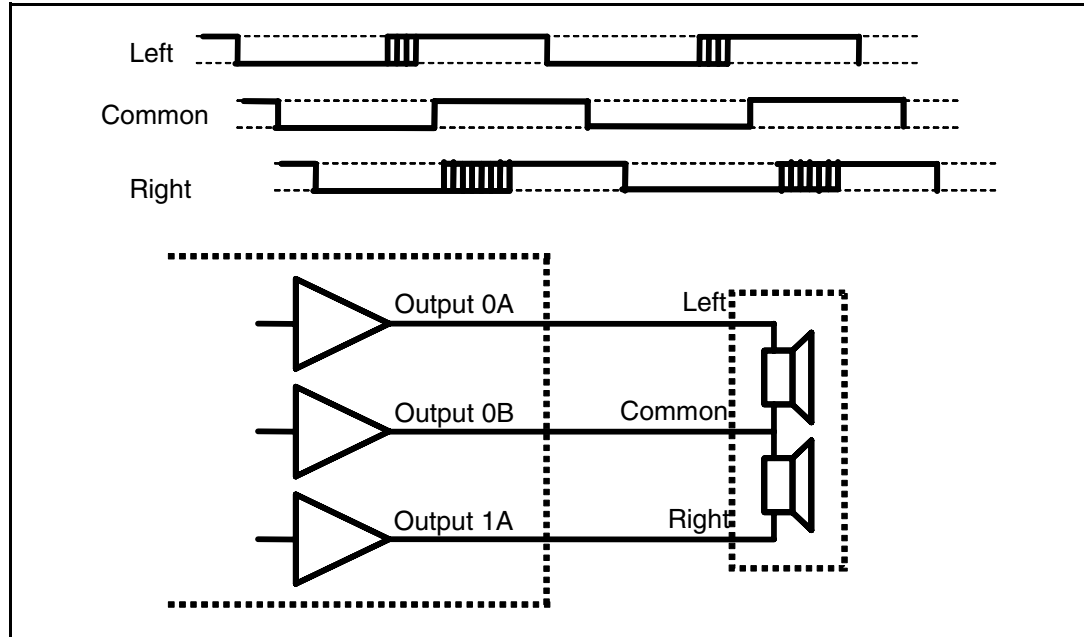

7.7 pfStart™ operation

In order to avoid pop noise the bypass capacitor, situated between the filtered amplifier output and the load in single-ended applications, needs to be pre-charged to half of the power supply voltage. This is usually done by connecting a resistive partition to the output and then disconnecting it at the end of the charging phase (see the analog pop free description in section 9).

In the STA321 the FFX digital pop-free feature allows the digital pre-charging of the bypass capacitor using the amplifier instead of a resistive partition. This active pre-charge is also faster than the resistive partition method. The digital pop-free function can be independently set on both power stages, that is, the CMOS bridge stage using bit CB_PFDIG and the embedded amplifier stage using bit EA_PFDIG in register *FFXCFG2* on page 83.

Registers CB_PFRAMP1-6 beginning on page 97 and EA_PFRAMP1-6 beginning on page 99 control the charging function. The register usage is given in the following description.

The capacitor is charged from zero to half the supply voltage with the PWM signal. By applying a suitable ramp to the input of the modulator the PWM signal begins from near 0% duty cycle to 50% duty cycle.

The method is based on a slow ramp signal (from ground to $V_{CC} / 2$), implemented using both pulse density modulation (PDM) and pulse width modulation (PWM). At the beginning of the ramp PDM is used starting from an initial value set by bits CBRMPINI and EARMPINI, and then switching to PWM when reaching a threshold value set by bits CBRMPH and EARMPH.

The total ramp time can be modified via bits EATIM_RMP and CBTIM_RMP.

Figure 35. Digital pop-free ramp implementation

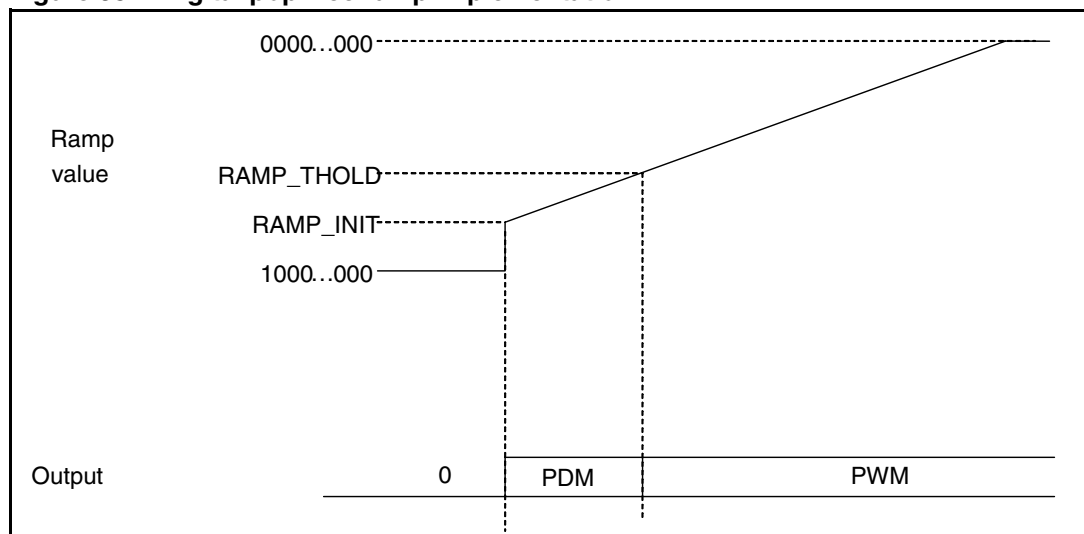

The PDM is realized with a noise shaper circuit, where the sampling time (T_d) of the noise shaper is equal to the minimum pulse size set by bits CBRMP_MP and EARMP_MP.

7.8 PWM00 output

Pin PWM00 is an additional output with a maximum driving capability of 2 mA to control an external bridge or external operational amplifier.

By default, PWM00 is tied to logical 0. When register bit CKOCFG[0] is set to 1 then any FFX PWM channel output can be mapped to it.

When the CMOS bridge is in standby the output PWM00 is, by default, turned off. However, it is possible to have the FFX signal PWM3A as the PWM00 output by using bit 3 of register [FFXCFG0 on page 82](#), and this whatever the status of power-down or the 3-state signals of both bridges, even if they are different from the normal operating mode where the output is 0 when in power-down or 3-state mode.

8 CMOS power stage

The CMOS half-bridge circuit of [Figure 36](#) is a single channel analog output power stage. There are three such output stages in the STA321, one for each of the outputs OUT1-3.

The switching mode is regulated by the logic circuit which ensures that the MOSFETs are switched in such a way as to avoid (or minimize) conditions where both the PMOS and the NMOS are conducting at the same time.

The input is a 1.8-V to 3.3-V level shifter followed by some combinational logic.

Figure 36. CMOS half bridge block diagram

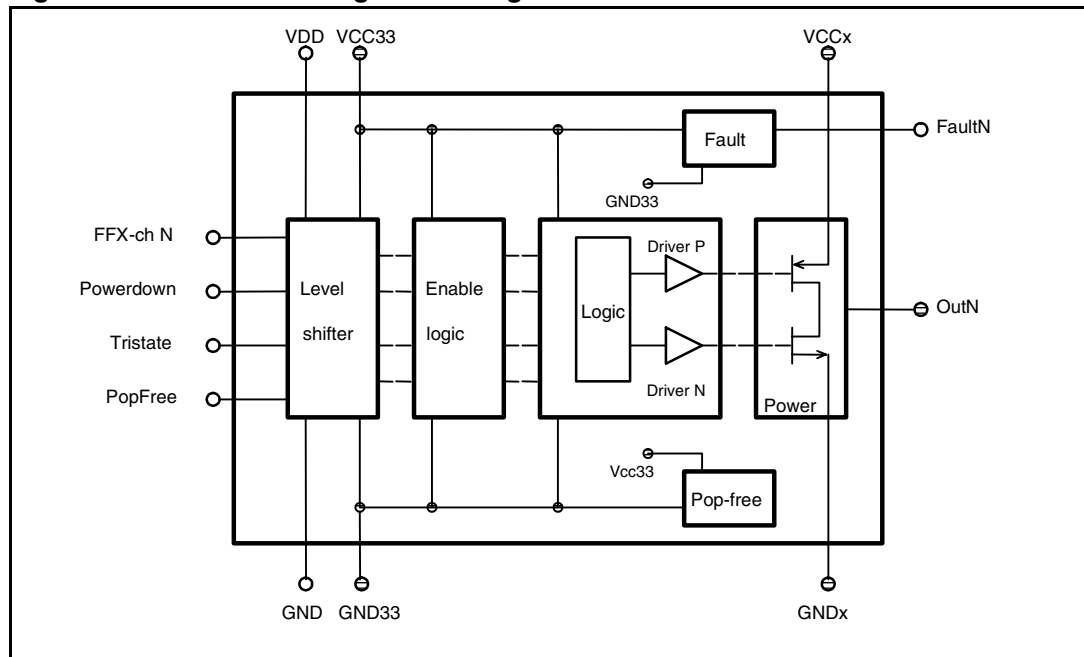

Table 24. CMOS bridge signal descriptions

| Pin Name | Direction | Description |
|-------------|-----------|---|
| FFX-ch | In | Digital audio signal coming from FFX block |
| Powerdown | In | Powerdown signal coming from the FFX block |
| Tristate | In | 3-state signal from the FFX block |
| PopFree | In | Pop-free signal from the FFX block |
| Fault | Out | Short-circuit fault output feedback signal to digital core (active low) |
| Out | Out | Channel half-bridge analog output |
| VCC33/GND33 | Supply | Pre-driver analog supply |
| VDD/GND | Supply | Digital core supply generated by internal regulator |
| VCCx/GNDx | Supply | Half-bridge power supply |

The CMOS bridge power rating can be calculated using the following formulas:

$$P (<1\%) = (R_L / 2) * (M * VCC / 2 / (R_L + 2 * R_{DS}))^2 \text{ for BTL}$$

$$P (<1\%) = (R_L / 2) * (M * VCC / 2 / (R_L + R_{DS}))^2 \text{ for single ended}$$

$$P (10\%) = 1.28 * P(<1\%)$$

where R_{DS} is composed of the MOST R_{DSON} and the board and connector parasitic resistances (including power supplies and coils) and M is the modulation index obtained from

$$M = 1 - 2 * (MIN_PLS_n + 1) / f_{clk_ffx} / \tau_S$$

where MIN_PLS_n is the value in register PWMOnCFG0 for channel n , f_{clk_ffx} is the frequency of the FFX clock and τ_S is the PWM clock period (384 kHz or 768 kHz selected by register bit [FFXCFG2.PWM_FREQ](#)).

For the CMOS bridge, MIN_PLS_n can be set to 0; this gives $M = 0.9922$.

Table 25. Power output (at 1% THD) in headphone mode

| Load, R_L in Ω | Power, P in mW (for 3.3-V supply) |
|-------------------------|-------------------------------------|
| 16 | 70 |
| 32 | 32 |

The analog pop_free function is available in the CMOS bridge circuit by setting the appropriate bridge start-up as per [Table 26](#). The CMOS bridge enable and pop-free signals are generated from the three signals Powerdown, Tristate and PopFree provided by the digital core and controlled/configured through register bits [FFXCFG1.CB_STBY](#), [FFXCFG1.CB_TRISTn](#) and [PFEFAULT.PFE](#)n for the three outputs, $n = 1$ to 3.

Figure 37. Analog pop-free schematic

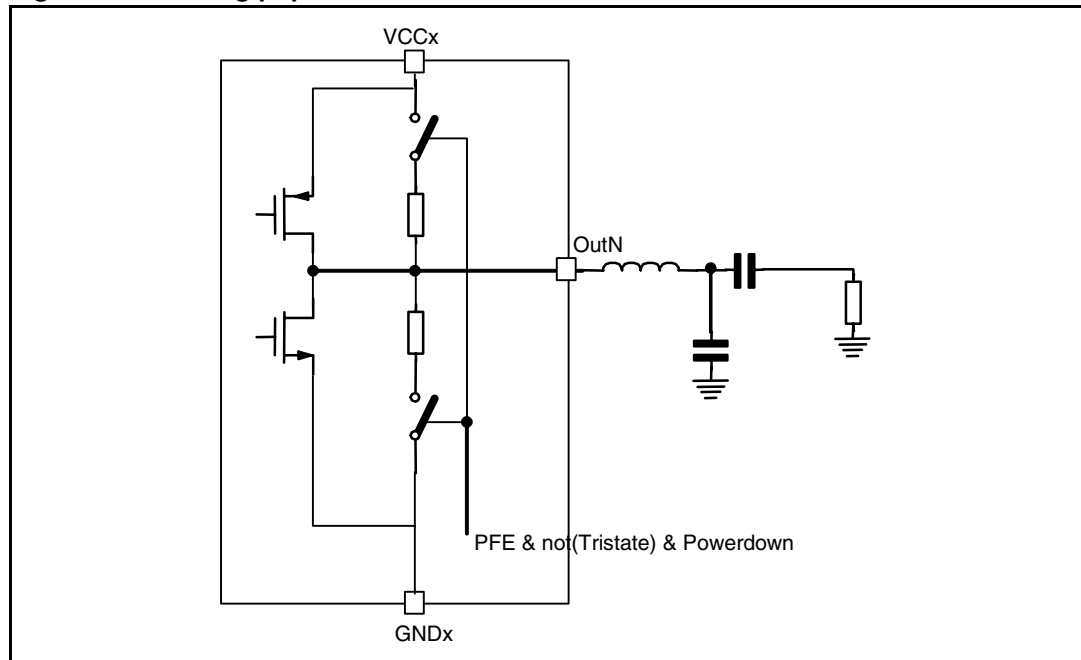

Table 26. Logic circuit at bridge input

| Powerdown | Tristate | PopFree | Pop-free resistors | Bridge status |
|-----------|----------|---------|--------------------|---------------|
| 0 | 0 | 0 | Disconnected | 3-state |
| 0 | 0 | 1 | Disconnected | 3-state |
| 1 | 0 | 1 | Connected | 3-state |
| 1 | 1 | 1 | Disconnected | On |
| 1 | 1 | 0 | Disconnected | On |

At the appropriate time the two pop-free resistors allow the bypass capacitor to be charged to $V_{CCx} / 2$. The STA321 generates automatically the bridge start-up and switch-off sequence to provide the correct charging. The time TT in [Figure 38](#) below is set using registers CBTTF0-1 and CBTTP0-1. TT must be chosen for the specific application depending on the decoupling capacitor, load and power supply.

After powerdown is applied again the decoupling capacitor discharges slowly due to capacitor leakage.

The analog pop-free implementation cannot be used with the digital pfStart implementation

Both analog and digital pop-free features must be disabled if binary headphone modulation is used.

Figure 38. Analog pop-free start-up and switch-off sequence

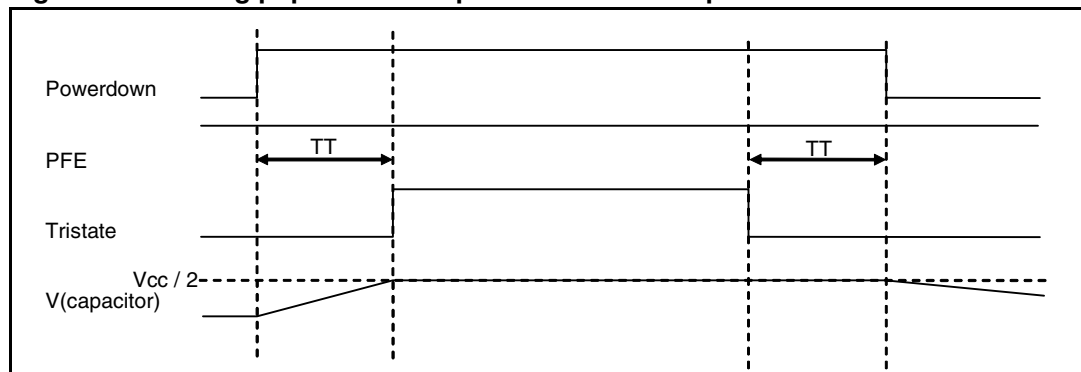

The CMOS bridge circuit includes over-current protection. The FAULT signal indicates to the output the status of the over-current condition due to a short circuit. The over-current thresholds detected by the CMOS bridge are fixed at 1.8 A.

9 Fault detection and recovery

9.1 External amplifier

When Fault is reported on pin EAFTN and bit EA_TSFT_ON of register [FFXCFG2 on page 83](#) is active, then pin EATSN is reset to 0 and the embedded bridge outputs are put in the high-impedance state. When the fault signal disappears (that is, goes to 1) the embedded bridge is kept in 3-state for a time defined in register EATTF0-1 [on page 86](#), after which time the outputs recover.

9.2 CMOS bridge

When Fault is reported to the digital core and CB_TSFT_ON of register [FFXCFG2 on page 83](#) is active then the tristate is activated thus putting the STA321 OUTn outputs in the high-impedance state. When the fault signal disappears, the CMOS bridge is kept in 3-state status for a time defined in register CBTTF0-1 [on page 88](#), after which time the outputs recover.

10 ADC

10.1 Description

The STA321 analog input is provided through a low-power, low-voltage complete low-cost analog-to-digital converter front end designed for stereo audio applications. It includes programmable gain amplifier, anti-aliasing filter, low-noise microphone biasing circuit, a third order MASH2-1 delta-sigma modulator, a digital decimating filter and a 1st-order DC-removal filter.

The ADC works with either a microphone input or a line input, selected using bit ADC_INSEL in register [ADCCFG0 on page 133](#).

A programmable gain amplifier (PGA) is available in microphone-in mode giving the possibility to amplify the signal from 0 to 42 dB in steps of 6 dB using register bit [ADCCFG0.ADC_PGA](#).

The ADC specifications are given in [Table 6 on page 14](#).

Figure 39. ADC front-end block diagram

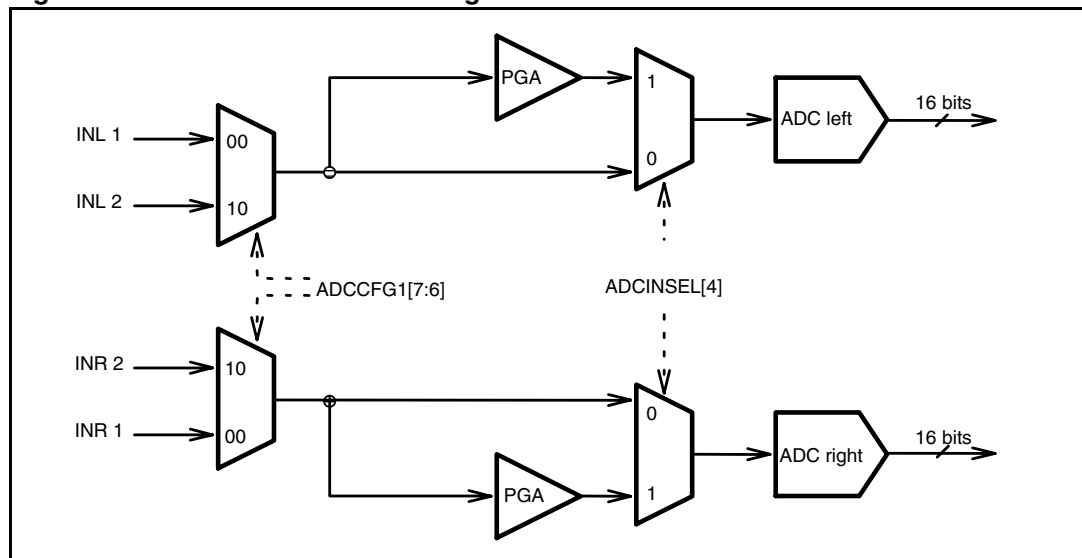

10.2 Application schematic

Figure 40. Typical connections for power supplies and inputs

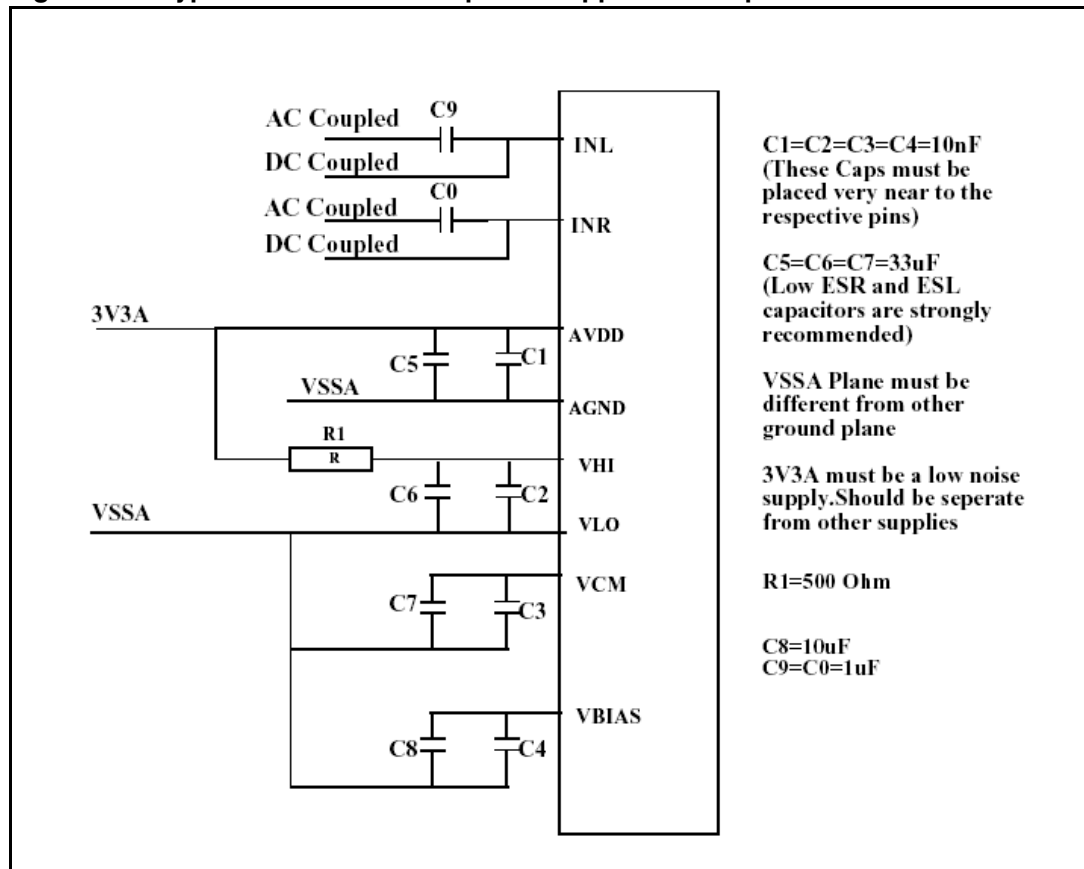

10.2.1 Configuration example

This is an example of the register setup for the ADC inputs. It is assumed that every peripheral is already configured and working correctly.

There are other configuration examples to help you get started please refer to other chapters and also to [Chapter 14: Register description on page 77](#) in order to get all the necessary and complementary details.

[Table 27](#) shows the register settings for selecting INL2 and INR2 as input source for SRC and SAI_out1 and using the PGA with a 12-dB gain.

Table 27. Example register settings for ADC

| Register | Value | Description |
|----------|-------|--|
| ADCCFG1 | 0x40 | Selecting INL2 and INR2 as sources |
| ADCCFG0 | 0x52 | PGA Gain = +12 dB, PGA enabled, ADC clock on |
| P2SDATA | 0x40 | ADC Data routed also to the SAI_out |

11 Serial audio interface

The data on pins SDATAI, SDATAO, LRCLKI and LRCLKO are always synchronous with the bit clock. The data on these pins changes with the BICLK active (or clocking) edge.

The BICLK strobe edge latches the data SDATAI, SDATAO, LRCLKI, LRCLKO; thus this data should be stable near the BICLK strobe edges. The slave device uses the strobe edges to latch the serial data internally.

The active and strobe edges can be selected to be the rising edge or the falling edge by appropriately programming register bits [SAI_IN1_CFG0\[7\]](#), [SAI_OUT_CFG0\[7\]](#) and [SAI_IN2_CFG0\[7\]](#).

The serial-to-parallel interface and the parallel-to-serial interface can have different sampling rates. [Figure 41](#) shows a typical setup.

Figure 41. SAI typical sampling rates

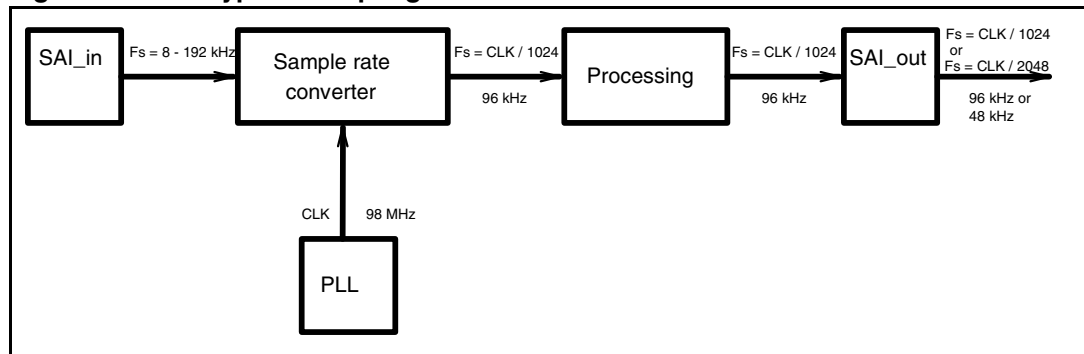

11.1 Master mode

In this mode BICLK/BICLKO and LRCLKI/LRCLKO are configured as outputs and are generated by the core.

Figure 42. Timing diagram for master mode

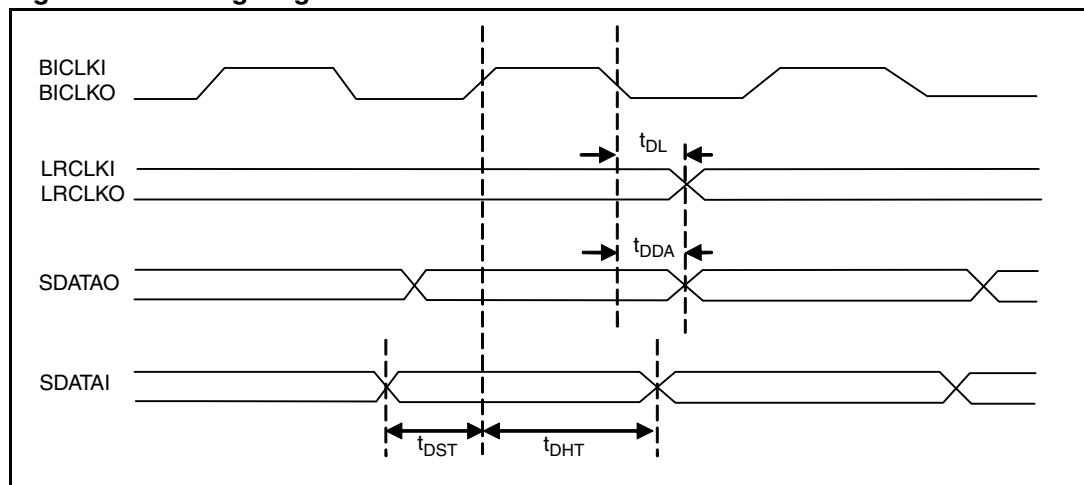

Table 28. Timing parameters for master mode

| Symbol | Parameter | Min | Typ | Max | Unit |
|-----------|--|-----|-----|-----|------|
| t_{DL} | LRCLKI/LRCLKO propagation delay from BICLK active edge | 0 | - | 10 | ns |
| t_{DDA} | SDATAI propagation delay from BICLK/O active edge | 0 | - | 15 | ns |
| t_{DST} | SDATAO setup time to BICLK/O strobing edge | 10 | - | - | ns |
| t_{DHT} | SDATAO hold time from BICLK/O strobing edge | 10 | - | - | ns |

11.2 Slave mode

In this mode BICLK/O and LRCLKI/O are configured as inputs and supplied by the external peripheral.

Figure 43. Timing diagram for slave mode

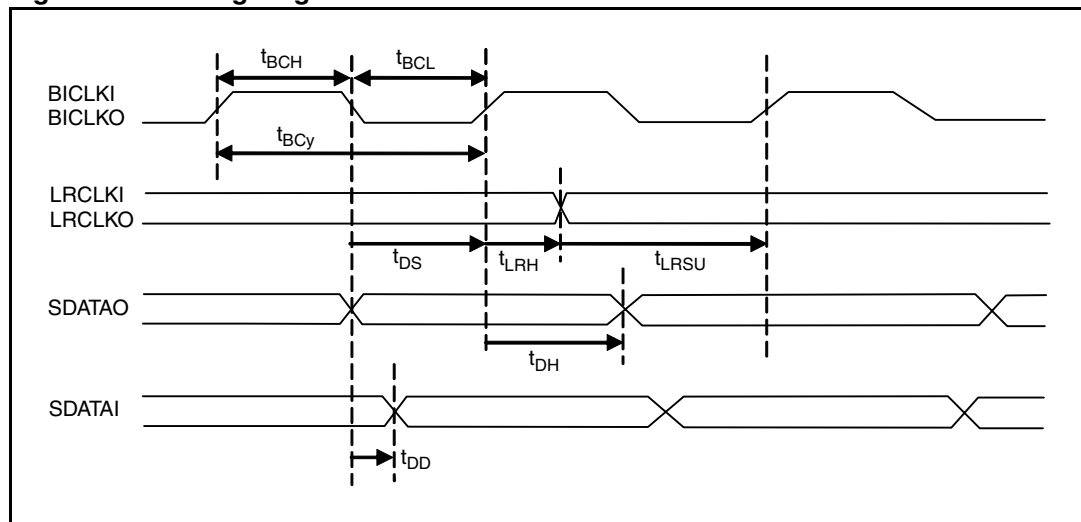

Table 29. Timing parameters for slave mode

| Symbol | Parameter | Min | Typ | Max | Unit |
|------------|---|-----|-----|-----|------|
| t_{BCy} | BICLK cycle time | 50 | - | - | ns |
| t_{BCH} | BICLK pulse width high | 20 | - | - | ns |
| t_{BCL} | BICLK pulse width low | 20 | - | - | ns |
| t_{LRSU} | LRCLKI/LRCLKO setup time to BICLK strobing edge | 10 | - | - | ns |
| t_{LRH} | LRCLKI/LRCLKO hold time to BICLK strobing edge | 10 | - | - | ns |
| t_{DS} | SDATAO setup time to BICLK strobing edge | 10 | - | - | ns |
| t_{DH} | SDATAO hold time to BICLK strobing edge | 10 | - | - | ns |
| t_{DD} | SDATAI propagation delay from BICLK active edge | 0 | - | 10 | ns |

11.3 Serial formats

Different audio formats are supported in both master and slave modes. Clock and data configurations can be customized to match most of the serial audio protocols available on the market.

Data length can be customized for 8, 16, 24 or 32 bits.

11.3.1 Right justified

Figure 44. Right justified serial format

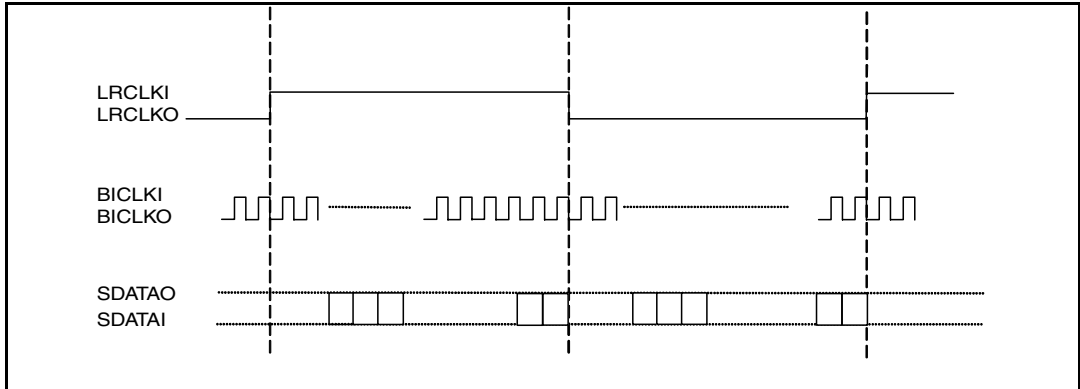

11.3.2 Left justified

Figure 45. Left justified serial format

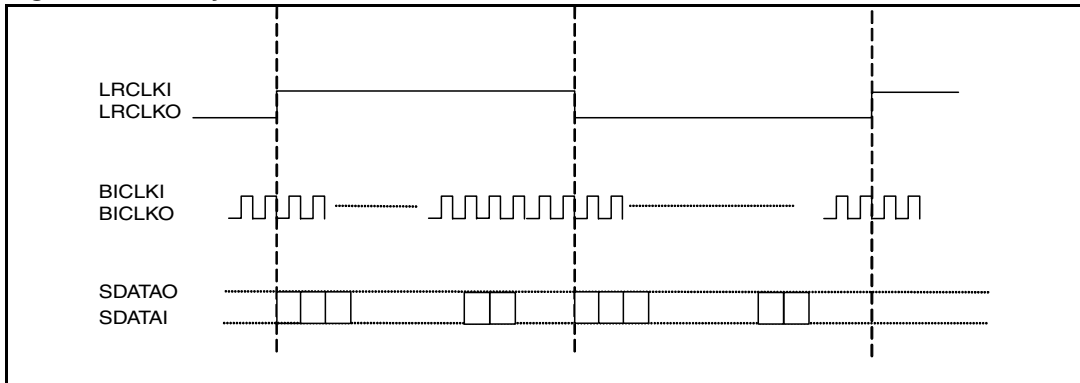

11.3.3 DSP

Figure 46. DSP serial format

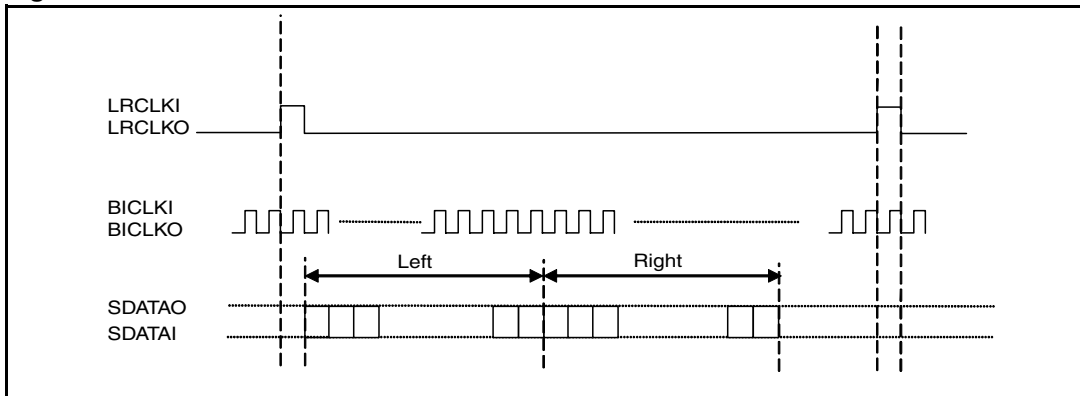

11.3.4 I²S

Figure 47. I²S serial format

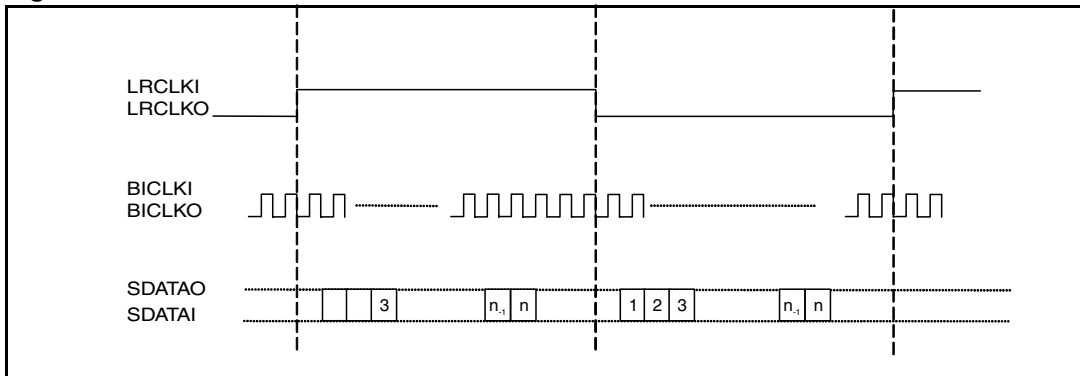

11.3.5 PCM/IF (non-delayed mode)

- MSB first
- 16-bit data.

Figure 48. PCM (non-delayed) serial format

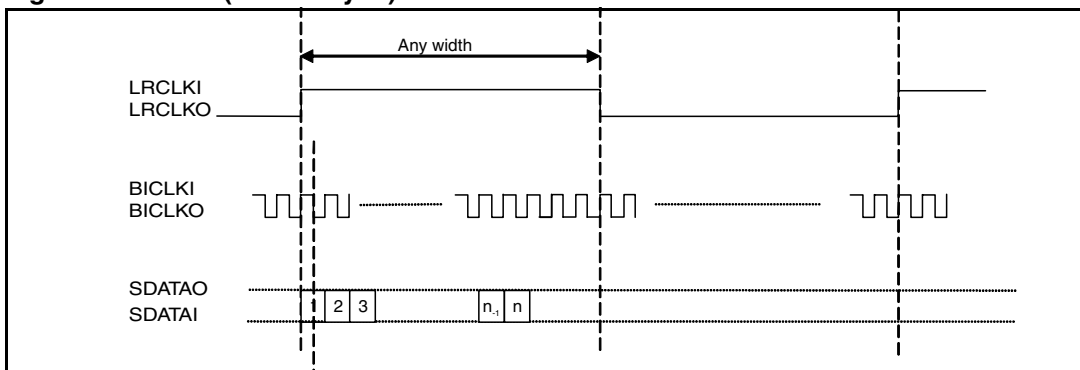

11.3.6 PCM/IF (delayed mode)

- MSB first
- 16-bit data.

Figure 49. PCM (delayed) serial format

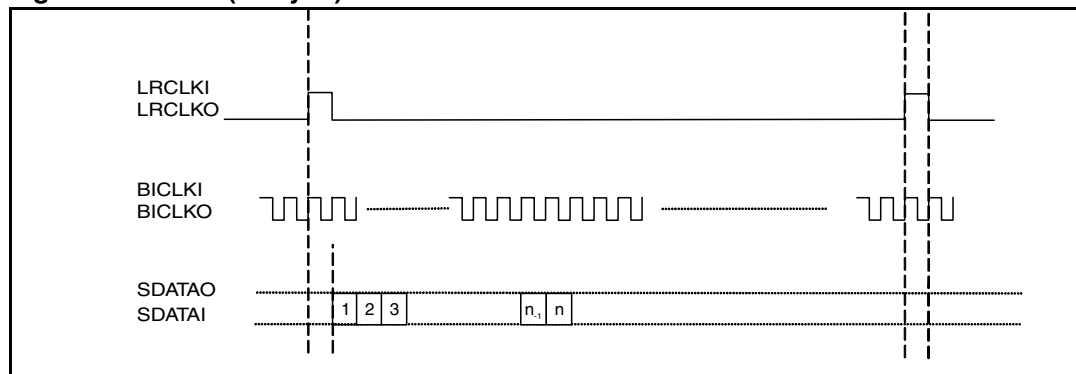

11.4 Invalid detection

STA321 has an invalid input detection feature that can detect an invalid serial interface bit clock or frame clock and then mute the processing channels to avoid any speaker or headphone damage and, moreover, to avoid loud audible transients which may be discomforting to the listener. The control is active only for the SAI input. The configuration programmed in bits 0, 1 and 2 of register *FFXCFG0* on page 82 is applicable to both SAI1 and SAI2 whilst the checks are independent for each interface. The mute on the processing channel is asserted depending on the input interface mapping.

Figure 50 shows the invalid detection schematic. Here, two different checks are available. The first one is enabled by register bit *FFXCFG0.BAD_CKS_M* and evaluates the ratio of BICLK and LRCLK. The resulting number must be the same as that written in bits S2Pn_BOS (for example, $32 * f_s$ or $64 * f_s$) in registers *SAI_IN1_CFG1* on page 123 and *SAI_IN2_CFG1*, otherwise the channels are muted.

The second check is enabled by register bit *FFXCFG0.MIS_BICK_M* and is related to the presence of BICLK. Basically, a 8-bit watchdog counter decrements, starting from 0xFF, with each edge of *clk_proc*. The counter is reset to 0xFF at each BICLK edge; so, if the watchdog counter ever reaches 0x00, a missing bit clock error is signalled and the mute command is issued.

Figure 50. Invalid input detection schematic

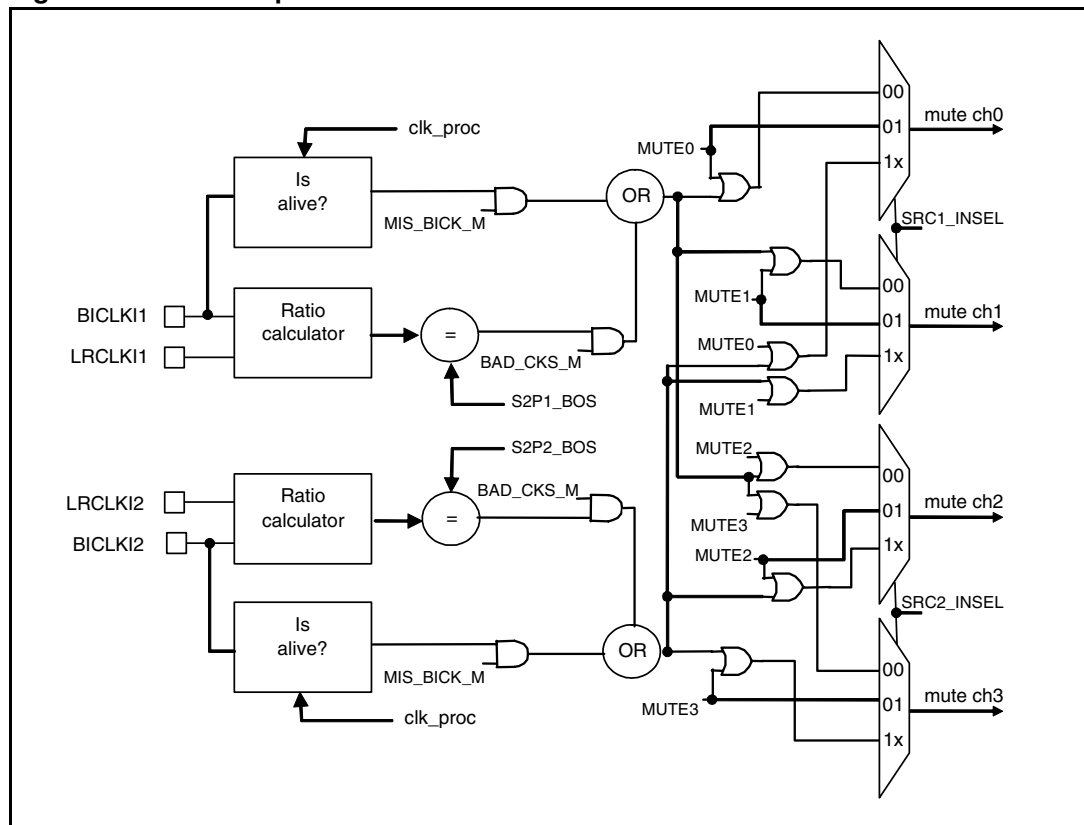

12 Headphone detection

The headphone detector circuit, shown in [Figure 51](#), is made with two schmitt-trigger comparators (with different thresholds) which sense the value of the HPDECT input voltage and modifies the HP_DET1 or the HP_DET2 level as given in [Table 30](#) and [Table 31](#) below. The comparators are enabled or disabled with bits E_HP1 and E_HP2 in register [HPDET2 on page 138](#)

Table 30. Headphone 1 detector

| E_HP1 (register HPDET2) | HP-jack status | HP_DET voltage | HP_DET1 | Status register bit HPDST.HP_DET_FILT |
|----------------------------|----------------|----------------|---------|--|
| 1 | Unplugged | Low | 0 | - |
| 1 | Plugged | High | 1 | - |
| 0 | X | X | 1 | - |

Table 31. Headphone 2 detector

| E_HP2 (register HPDET2) | HP-jack status | HP_DET voltage | HP_DET2 | Status register bit HPDST.HP_DET_FILT |
|----------------------------|----------------|----------------|---------|--|
| 1 | Unplugged | Low | 1 | - |
| 1 | Plugged | High | 0 | - |
| 0 | X | X | 1 | - |

The comparator output status is provided via bits 1 and 0 of register [HPDET2 on page 138](#). One of the comparator outputs is then selected with register bit [HPDET1.HPD_SEL](#), and that signal is passed through a digital debouncing filter and supplied to the FFX modulator. The PWM outputs are then modified depending on the settings of register bits [HPDST.HP_DET_FILT](#) and [HPDET1.HPD_ACT_MODE](#).

12.1 Applications circuits

Two applications circuits are given here, one for the binary single-ended application and one for the binary headphone application.

Figure 51. Headphone detection circuit for single-ended configuration

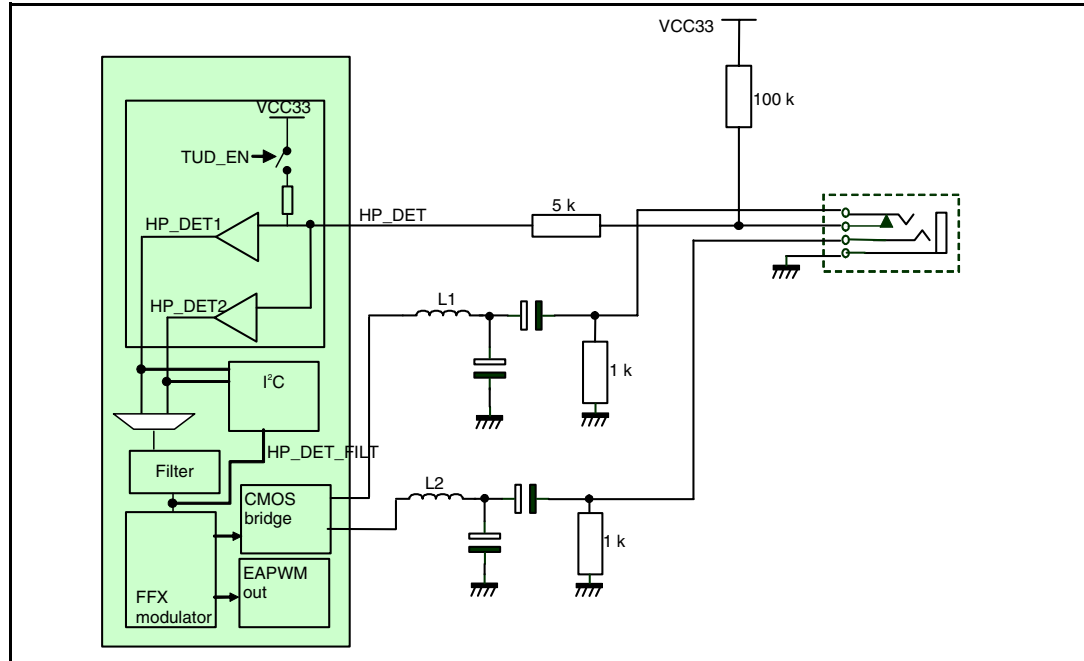
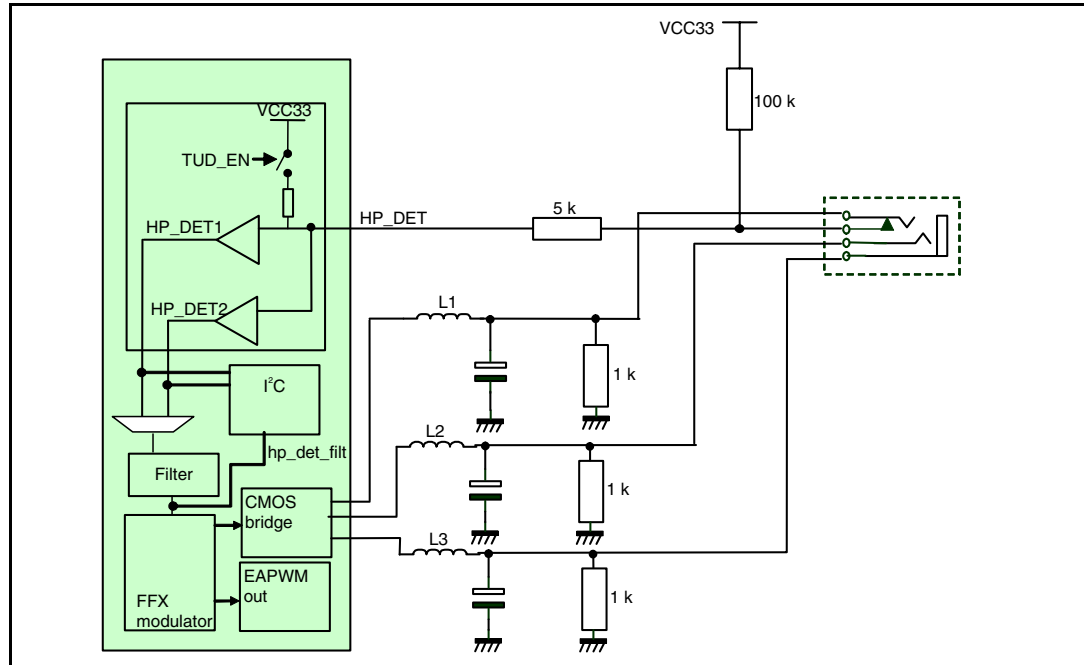

Figure 52. Headphone detection circuit for binary HP configuration



12.2 Configuration example

This is an example of the register setup for headphones detection. It is assumed that every peripheral is already configured and working correctly.

There are other configuration examples to help you get started please refer to other chapters and also to [Chapter 14: Register description on page 77](#) in order to get all the necessary and complementary details.

[Table 32](#) and [Table 33](#) below give a possible setup for the headphones detection configurations shown in [Figure 51](#) and [Figure 52](#), respectively.

Table 32. Headphone detection configuration sequence for binary SE

| Register | Value | Description |
|--|-------|---|
| MISC on page 135 | 0x21 | Enable core clock |
| PLL on page 136 | 0x00 | Use PLL clock |
| User FFX and CMOS bridge configuration | | |
| HPDET2 on page 138 | 0x80 | Disable the HP_DET pull-up |
| HPDET1 on page 137 | 0x57 | Use HP1 for hpdet filter; polarity = high; action = mute; mod = binary SE; average time 170 ms. |
| HPDET2 on page 138 | 0x80 | Select E_HP1 comparator |
| FFXCFG1 on page 81 | 0x00 | Remove the tristate from the bridges |

Table 33. Headphone detection configuration sequence for binary headphone

| Register | Value | Description |
|--|-------|---|
| MISC on page 135 | 0x21 | Enable core clock |
| PLL on page 136 | 0x00 | Use PLL clock |
| User FFX and CMOS bridge configuration | | |
| HPDET2 on page 138 | 0x80 | Disable the HP_DET pull-up |
| HPDET1 on page 137 | 0x5F | Use HP1 for hpdet filter; polarity = high; action = mute; mod = binary HP; average time 170 ms. |
| HPDET2 on page 138 | 0x80 | Select E_HP1 comparator |
| FFXCFG1 on page 81 | 0x00 | Remove the tristate from the bridges |

Note: The pullup on HPDET pad must always be disabled before using the HPDET function.

Note: Comparator 1 and comparator 2 cannot be enabled simultaneously.

13 I²C interface

13.1 Communication protocol

13.1.1 Data transition and change

Data changes on the SDA line must only occur when the SCL clock is low. SDA transition while the clock is high is used to identify a START or STOP condition.

13.1.2 Start condition

START is identified by a high to low transition of the SDA bus while the clock signal, SCL, is stable in the high state. A START condition must precede any command for data transfer.

13.1.3 Stop condition

STOP is identified by a low to high transition on the SDA bus while the clock signal, SCL, is stable in the high state. A STOP condition terminates communication between STA321 and the bus master.

13.1.4 Data input

During the data input the STA321 samples the SDA signal on the rising edge of clock SCL. For correct device operation the SDA signal must be stable during the rising edge of the clock and the data can change only when the SCL line is low.

13.1.5 Device addressing

To start communication between the master and the STA321, the master initiates with a start condition. Following this, the master sends 8 bits (MSB first) on the SDA line which corresponds to the device select address and read or write mode.

The 7 MSBs are the device address identifiers, corresponding to the I²C bus definition. In the STA321 the I²C interface has the device address 0x30.

After a START condition the STA321 identifies the device address and if a match is found, acknowledges the identification on SDA bus during the 9th bit time. The byte following the device identification byte is the internal space address.

13.1.6 Write operation

Following the START condition the master sends a device select code with the RW bit set to 0. After the STA321 acknowledge, the master sends the byte of internal address. On receiving the internal byte address the STA321 responds with acknowledge.

Byte write

In the byte write mode the master sends one data byte, this is acknowledged by the STA321. The master then terminates the transfer by generating a STOP condition.

Multi-byte write

The multi-byte write mode starts from any internal address. The master generates a STOP condition to terminate the transfer.

13.1.7 Read operation

Current address byte read

Following the START condition the master sends a device select code with the RW bit set to 1. The STA321 acknowledges and then responds by sending one byte of data. The master then terminates the transfer by generating a STOP condition.

Current address multi-byte read

The multi-byte read mode start from any internal address. Data bytes are read from sequential addresses within the STA321. The master acknowledges each data byte read and then generates a STOP condition to terminate the transfer.

Random address byte read

Following the START condition the master sends a device select code with the RW bit set to 0. The STA321 acknowledges and then the master writes the internal address byte. After receiving, the internal byte address the STA321 again responds with an acknowledge. The master then initiates another START condition and sends the device select code with the RW bit set to 1. The STA321 acknowledges this and then responds by sending one byte of data. The master then terminates the transfer by generating a STOP condition.

Random address multi-byte read

The multi-byte read modes start from any internal address. Data bytes are read from sequential addresses within the STA321. The master acknowledges each data byte read and then generates a STOP condition to terminate the transfer.

Figure 53. I²C write operations

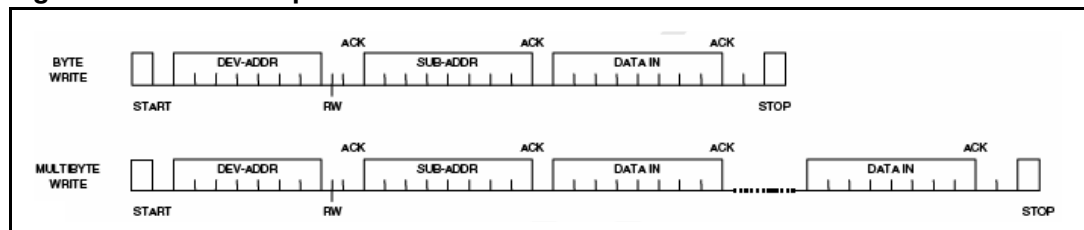
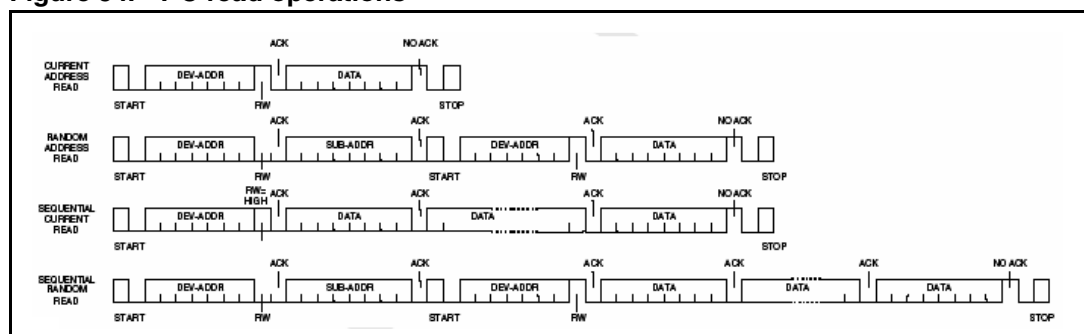

Figure 54. I²C read operations



14 Register description

Table 34. Register summary

| Register | Addr | 7 | 6 | 5 | 4 | 3 | 2 | 1 | 0 | |
|------------|------|----------------|----------------|---------------|--------------|----------------|---------------|--------------|-------------|--|
| FFXCFG1 | 0x00 | EA_STBY | CB_STBY | EA_TRIST | FFX_ULCK_PLL | | CB_TRIST2 | CB_TRIST1 | CB_TRIST0 | |
| FFXCFG0 | 0x01 | MUTE3 | MUTE2 | MUTE1 | MUTE0 | PWM00_3A | BAD_IN_M | BAD_CKS_M | MIS_BICK_M | |
| FFXCFG2 | 0x02 | RESET_NOISH | PWM_FREQ | NS_ORD[1:0] | | EA_TSFT_ON | CB_TSFT_ON | EA_PFDIG | CB_PFDIG | |
| PWMMAP1 | 0x03 | CB1_MAP[2:0] | | | CB2_MAP[2:0] | | | CB3_MAP[2:1] | | |
| PWMMAP2 | 0x04 | CB3_MAP[0] | PWM00_MAP[2:0] | | | EA1A_MAP[2:0] | | | EA1B_MAP[2] | |
| PWMMAP3 | 0x05 | EA1B_MAP[1:0] | | EA2A_MAP[2:0] | | | EA2B_MAP[2:0] | | | |
| EATTF0 | 0x06 | EATTF[7:0] | | | | | | | | |
| EATTF1 | 0x07 | EATTF[7:0] | | | | | | | | |
| EATTP0 | 0x08 | EATTP[15:8] | | | | | | | | |
| EATTP1 | 0x09 | EATTP[7:0] | | | | | | | | |
| CBTTF0 | 0x0A | CBTTF[15:8] | | | | | | | | |
| CBTTF1 | 0x0B | CBTTF[7:0] | | | | | | | | |
| CBTTP0 | 0x0C | CBTTP[15:8] | | | | | | | | |
| CBTTP1 | 0x0D | CBTTP[7:0] | | | | | | | | |
| FFXST | 0x0E | EA_MPWM | CB_MPWM | EARMP_ST[1:0] | | CBRMP_ST[1:0] | | EABINSS_AC | CBBINSS_AC | |
| POWST | 0x0F | Reserved | | | | EA_TW | EA_PD | EA_FT | EA_TS | |
| POWST1 | 0x10 | Reserved | CB_PD | CB_FT[2:0] | | | CB_TS[2:0] | | | |
| PWMO1CFG0 | 0x11 | AZPLS_1 | TERNARY_1 | HALFB_1 | MP_ZERO_1 | MIN_PLS_1[3:0] | | | | |
| PWMO1CFG1 | 0x12 | PM_1A[1:0] | | | PS_1A[5:0] | | | | | |
| PWMO1CFG2 | 0x13 | PM_1B[1:0] | | | PS_1B[5:0] | | | | | |
| PWMO2CFG0 | 0x14 | AZPLS_2 | TERNARY_2 | HALFB_2 | MP_ZERO_2 | MIN_PLS_2[3:0] | | | | |
| PWMO2CFG1 | 0x15 | PM_2A[1:0] | | | PS_2A[5:0] | | | | | |
| PWMO2CFG2 | 0x16 | PM_2B[1:0] | | | PS_2B[5:0] | | | | | |
| PWMO3CFG0 | 0x17 | AZPLS_3 | TERNARY_3 | HALFB_3 | MP_ZERO_3 | MIN_PLS_3[3:0] | | | | |
| PWMO3CFG1 | 0x18 | PM_3A[1:0] | | | PS_3A[5:0] | | | | | |
| PWMO3CFG2 | 0x19 | PM_3B[1:0] | | | PS_3B[5:0] | | | | | |
| PWMO4CFG0 | 0x1A | AZPLS_4 | TERNARY_4 | HALFB_4 | MP_ZERO_4 | MIN_PLS_4[3:0] | | | | |
| PWMO4CFG1 | 0x1B | PM_4A[1:0] | | | PS_4A[5:0] | | | | | |
| PWMO4CFG2 | 0x1C | PM_4B[1:0] | | | PS_4B[5:0] | | | | | |
| CB_PFRAMP1 | 0x20 | CBRMP_MP[5:0] | | | | | | Reserved | | |
| CB_PFRAMP2 | 0x21 | CBRMPINI[15:8] | | | | | | | | |
| CB_PFRAMP3 | 0x22 | CBRMPINI[7:0] | | | | | | | | |
| CB_PFRAMP4 | 0x23 | CBTIM_RMP[3:0] | | | | Reserved | | | | |
| CB_PFRAMP5 | 0x24 | CBRMPPTH[15:8] | | | | | | | | |
| CB_PFRAMP6 | 0x25 | CBRMPPTH[7:0] | | | | | | | | |
| EA_PFRAMP1 | 0x26 | EARMP_MP[5:0] | | | | | | Reserved | | |
| EA_PFRAMP2 | 0x27 | EARMPINI[15:8] | | | | | | | | |

Table 34. Register summary (continued)

| Register | Addr | 7 | 6 | 5 | 4 | 3 | 2 | 1 | 0 | |
|-------------|------|----------------|------------|-----------|-----------------|-----------|-----------|------------|------------|-------------|
| EA_PFRAMP3 | 0x28 | EARMPINI[7:0] | | | | | | | | |
| EA_PFRAMP4 | 0x29 | EATIM_RMP[3:0] | | | | Reserved | | | | |
| EA_PFRAMP5 | 0x2A | EARMPTH[15:8] | | | | | | | | |
| EA_PFRAMP6 | 0x2B | EARMPTH[7:0] | | | | | | | | |
| SRC1STATE | 0x30 | SRC1_BYP[1:0] | SRC_1_LOCK | | SRC1_FISFO[4:0] | | | | | |
| SRC2STATE | 0x31 | SRC1_BYP[1:0] | SRC_1_LOCK | | SRC1_FISFO[4:0] | | | | | |
| I2CB0_TOP | 0x51 | I2CB0[23:16] | | | | | | | | |
| I2CB0_MID | 0x52 | I2CB0[15:8] | | | | | | | | |
| I2CB0_BOT | 0x53 | I2CB0[7:0] | | | | | | | | |
| I2CB1_TOP | 0x54 | I2CB1[23:16] | | | | | | | | |
| I2CB1_MID | 0x55 | I2CB1[15:8] | | | | | | | | |
| I2CB1_BOT | 0x56 | I2CB1[7:0] | | | | | | | | |
| I2CB2_TOP | 0x57 | I2CB2[23:16] | | | | | | | | |
| I2CB2_MID | 0x58 | I2CB2[15:8] | | | | | | | | |
| I2CB2_BOT | 0x59 | I2CB2[7:0] | | | | | | | | |
| I2CA1_TOP | 0x5A | I2CA1[23:16] | | | | | | | | |
| I2CA1_MID | 0x5B | I2CA1[15:8] | | | | | | | | |
| I2CA1_BOT | 0x5C | I2CA1[7:0] | | | | | | | | |
| I2CA2_TOP | 0x5D | I2CA2[23:16] | | | | | | | | |
| I2CA2_MID | 0x5E | I2CA2[15:8] | | | | | | | | |
| I2CA2_BOT | 0x5F | I2CA2[7:0] | | | | | | | | |
| PROCCTRL | 0x60 | Reserved | | | | RA | Reserved | WA | W1 | |
| START_ADD2 | 0x61 | Reserved | | | | | | | | I2CSTART_A8 |
| START_ADD | 0x62 | I2CSTART_A7_A0 | | | | | | | | |
| ROM_REMAP | 0x6F | Reserved | ENAB_PRE3 | ENAB_PRE2 | ENAB_PRE1 | ENAB_PRE0 | ENAB_POST | ENAB_PRMIX | ENAB_DELAY | |
| BYP_EN_CH0 | 0x70 | Reserved | | | | | | | | |
| EFFS_EN_CH0 | 0x71 | Reserved | | | | | | EROM09 | EROM08 | |
| BYP_EN_CH1 | 0x72 | Reserved | | | | | | | | |
| EFFS_EN_CH1 | 0x73 | Reserved | | | | | | EROM19 | Reserved | |
| BYP_EN_CH2 | 0x74 | Reserved | | | | | | | | |
| EFFS_EN_CH2 | 0x75 | Reserved | | | | | | EROM29 | EROM28 | |
| BYP_EN_CH3 | 0x76 | Reserved | | | | | | | | |
| EFFS_EN_CH3 | 0x77 | Reserved | | | | | | EROM39 | Reserved | |
| BASS_SEL0_R | 0x78 | Reserved | | BASS_EN0 | BASS_SEL0 | | | | | |
| BASS_SEL1_R | 0x79 | Reserved | | BASS_EN1 | BASS_SEL1 | | | | | |
| BASS_SEL2_R | 0x7A | Reserved | | BASS_EN2 | BASS_SEL2 | | | | | |
| BASS_SEL3_R | 0x7B | Reserved | | BASS_EN3 | BASS_SEL3 | | | | | |
| TREB_SEL0_R | 0x7C | Reserved | | TREB_EN0 | TREB_SEL0 | | | | | |
| TREB_SEL1_R | 0x7D | Reserved | | TREB_EN1 | TREB_SEL1 | | | | | |
| TREB_SEL2_R | 0x7E | Reserved | | TREB_EN2 | TREB_SEL2 | | | | | |

Table 34. Register summary (continued)

| Register | Addr | 7 | 6 | 5 | 4 | 3 | 2 | 1 | 0 | |
|--------------|------|----------------|----------------|------------|-------------|------------|-------------|------------|------------|--|
| TREB_SEL3_R | 0x7F | Reserved | | TREB_EN3 | TREB_SEL3 | | | | | |
| SATCH0CFG1 | 0x90 | SAT_EQ | SAT_CH0[22:16] | | | | | | | |
| SATCH0CFG2 | 0x91 | SAT_CH0[15:8] | | | | | | | | |
| SATCH0CFG3 | 0x92 | SAT_CH0[7:0] | | | | | | | | |
| SATCH1CFG1 | 0x93 | Reserved | SAT_CH1[22:16] | | | | | | | |
| SATCH1CFG2 | 0x94 | SAT_CH1[15:8] | | | | | | | | |
| SATCH1CFG3 | 0x95 | SAT_CH1[7:0] | | | | | | | | |
| SATCH2CFG1 | 0x96 | Reserved | SAT_CH2[22:16] | | | | | | | |
| SATCH2CFG2 | 0x97 | SAT_CH2[15:8] | | | | | | | | |
| SATCH2CFG3 | 0x98 | SAT_CH2[7:0] | | | | | | | | |
| SATCH3CFG1 | 0x99 | Reserved | SAT_CH3[22:16] | | | | | | | |
| SATCH3CFG2 | 0x9A | SAT_CH3[15:8] | | | | | | | | |
| SATCH3CFG3 | 0x9B | SAT_CH3[7:0] | | | | | | | | |
| VOLCFG | 0xA0 | SVOL_ON3 | SVOL_ON2 | SVOL_ON1 | SVOL_ON0 | TIM_SVOL | | | | |
| MVOL | 0xA1 | MVOL | | | | | | | | |
| VOLCH0 | 0xA2 | CVOL0 | | | | | | | | |
| VOLCH1 | 0xA3 | CVOL1 | | | | | | | | |
| VOLCH2 | 0xA4 | CVOL2 | | | | | | | | |
| VOLCH3 | 0xA5 | CVOL3 | | | | | | | | |
| SAI_IN1_CFG0 | 0xB0 | S2P1_B_STR | S2P1_LR_L | Reserved | S2P1_MSB | S2P1_DFM | | | S2P1_MMD | |
| SAI_IN1_CFG1 | 0xB1 | S2P1_DLEN | | S2P1_BOS | | S2P1_MAP_L | | S2P1_MAP_R | | |
| SAI_OUT_CFG0 | 0xB2 | P2S_B_STR | P2S_LR_L | SDATAO_ACT | P2S_MSB | P2S_DFM | | | P2S_MMD | |
| SAI_OUT_CFG1 | 0xB3 | P2S_DLEN | | P2S_BOS | | P2S_MAP_L | | P2S_MAP_R | | |
| SAI_IN2_CFG0 | 0xB4 | S2P2_B_STR | S2P2_LR_L | Reserved | S2P2_MSB | S2P2_DFM | | | S2P2_MMD | |
| SAI_IN2_CFG1 | 0xB5 | S2P2_DLEN | | S2P2_BOS | | S2P2_MAP_L | | S2P2_MAP_R | | |
| AUIFSHARE | 0xB6 | Reserved | | | | | | | SHARE_BILR | |
| SRCINSEL | 0xB7 | SRC1_INSEL | | SRC2_INSEL | | MUTE_SRCU | Reserved | | | |
| P2SDATA | 0xB8 | Reserved | P2S_HFS | P2S1_DSEL | | | P2S2_DSEL | | | |
| PLLCFG0 | 0xC0 | PLL_DPROG | PLL_FR_CTRL | PLL_DDIS | | PLL_IDF | | | | |
| PLLCFG1 | 0xC1 | PLL_FRAC[15:8] | | | | | | | | |
| PLLCFG2 | 0xC2 | PLL_FRAC[7:0] | | | | | | | | |
| PLLCFG3 | 0xC3 | PLL_STRB | PLL_STRBBYP | PLL_NDIV | | | | | | |
| PLLPFE | 0xC4 | PLL_BYP_UNL | BICKL2PLL | PLL_PWDN | PLL_NOPDDIV | Reserved | | | | |
| PLLST | 0xC5 | PLL_UNLOCK | PLL_PWD_ST | PLL_BYP_ST | Reserved | | | | | |
| ADCCFG0 | 0xC6 | ADC_PGA | | | ADC_INSEL | ADC_STBY | ADC_BYPCAL | CLK_ADC_ON | Reserved | |
| CKOCFG | 0xC7 | CLKOUT_DIS | CLKOUT_SEL | | CLK_FFX_ON | CLK_SRC_ON | CLK_PROC_ON | EAPWM_DIS | PWM00ACT | |
| MISC | 0xC8 | OSC_DIS | S2P_FS_RNG | | | ADC_FS_RNG | | P2P_IN_ADC | CLKCORE_ON | |

Table 34. Register summary (continued)

| Register | Addr | 7 | 6 | 5 | 4 | 3 | 2 | 1 | 0 |
|------------|------|----------------|------------|--------------|------------|-------------|------------|-------------|--------------|
| PLL_B | 0xC9 | PLL_BYP | Reserved | ADC_CLKSEL | Reserved | P2S1_CLKSEL | Reserved | P2S2_CLKSEL | Reserved |
| HPDET1 | 0xCA | HPD_SEL | HPD_POL | HPD_ACT_MODE | | HPD_HPMOD | HPD_TIM_F | | |
| HPDET2 | 0xCB | E_HP2 | E_HP1 | TUD_EN | Reserved | | | E_HPDET1 | E_HPDET2 |
| HPDST | 0xCC | HPD_DET_FILTER | Reserved | | | | | | |
| STBY_MODES | 0xCD | PAD_PULLDIS | Reserved | | | | | CMP_EN_N | DC_STBY_EN_N |
| ADCCFG1 | 0xCE | ADC_ANA_SEL | | Reserved | | | | | |
| PFEFAULT | 0xCF | Reserved | | | PFE1 | PFE2 | PFE3 | RESET_EA_FT | RESET_CB_FT |
| BISTRUN0 | 0xD0 | SF1_BRUN | SF2_BRUN | SS1_BRUN | SS2_BRUN | CF_BRUN | PR_BRUN | CF_ROM_BRUN | Reserved |
| BISTRUN1 | 0xD1 | OS_BRUN | DB_BRUN | Reserved | | | | | |
| BISTST0 | 0xD2 | SF1_BEND | SF1_BBAD | SF1_BFAIL | SF2_BEND | SF2_BBAD | SF2_BFAIL | SS1_BEND | SS1_BBAD |
| BISTST1 | 0xD3 | SS1_BFAIL | SS2_BEND | SS2_BBAD | SS2_BFAIL | CF_BEND | CF_BBAD | CF_BFAIL | PR_BEND |
| BISTST2 | 0xD4 | PR_BBAD | PR_BFAIL | OS_BEND | OS_BBAD | OS_BFAIL | DB_BEND | DB_BBAD | DB_BFAIL |
| BISTST3 | 0xD5 | CF_ROM_BEND | Reserved | | | | | | |
| ROMSIGN0 | 0xD6 | CF_ROMS[7:0] | | | | | | | |
| ROMSIGN1 | 0xD7 | CF_ROMS[15:8] | | | | | | | |
| ROMSIGN2 | 0xD8 | CF_ROMS[23:16] | | | | | | | |
| DEBUG0 | 0xD9 | DBGCKO_ON | DBGCKO_VAL | | | | | | |
| PADST0 | 0xF0 | PAD_RSTN | Reserved | PAD_SCL | PAD_SDA | PAD_I2CDIS | Reserved | | PAD_STBY |
| PADST1 | 0xF1 | PAD_MUTE | PAD_BICLKI | PAD_LRCLKI | PAD_SDATAI | PAD_BICLKO | PAD_LRCLKO | Reserved | |

FFXCFG1

| 7 | 6 | 5 | 4 | 3 | 2 | 1 | 0 |
|---------|---------|----------|--------------|---|-----------|-----------|-----------|
| EA_STBY | CB_STBY | EA_TRIST | FFX_ULCK_PLL | | CB_TRIST2 | CB_TRIST1 | CB_TRIST0 |

Address: 0x00**Type:** RW**Reset:** 0xD0**Description:**

- [7] EA_STBY
 - 0: the external bridge is active
 - 1: the external bridge is in standby mode
- [6] CB_STBY
 - 0: the bridge is active
 - 1: the bridge is in standby mode
- [5] EA_TRIST
 - 0: normal behaviour
 - 1: the external bridge is put in 3-state mode
- [4:3] FFX_ULCK_PLL: behavior of the FFX modulator in the event of the PLL losing lock:
 - 00: do nothing
 - 01: FFX hard mute (equivalent to using pin MUTE)
 - 10: FFX standby
 - 11: FFX hard mute and noise-shaper reset
- [2] CB_TRIST2
 - 0: the bridge is active
 - 1: force CMOS bridge OUT3 to 3-state
- [1] CB_TRIST1
 - 0: the bridge is active
 - 1: force CMOS bridge OUT2 to 3-state
- [0] CB_TRIST0
 - 0: normal behaviour
 - 1: force CMOS bridge OUT1 to 3-state

FFXCFG0

| 7 | 6 | 5 | 4 | 3 | 2 | 1 | 0 |
|-------|-------|-------|-------|----------|----------|-----------|------------|
| MUTE3 | MUTE2 | MUTE1 | MUTE0 | PWM00_3A | BAD_IN_M | BAD_CKS_M | MIS_BICK_M |

Address: 0x01**Type:** RW**Reset:** 0x07**Description:**

- [7] MUTE3
 - 0: normal behaviour
 - 1: force the mute in the channel 3
- [6] MUTE2
 - 0: normal behaviour
 - 1: force the mute in the channel 2
- [5] MUTE1
 - 0: normal behaviour
 - 1: force the mute in the channel 1
- [4] MUTE0
 - 0: normal behaviour
 - 1: force the mute in the channel 0
- [3] PWM00_3A
 - 0: output PWM00 is driven by FFX (default)
 - 1: output PWM00 comes from FFX output PWM3A and is not sensitive to bridge power-down or 3-state states
- [2] BAD_IN_M
 - Depending on the bit 0 and bit 1 settings
 - 0: mute with a ramp
 - 1: mute instantaneously
- [1] BAD_CKS_M
 - 0: FFX not muted
 - 1: FFX muted if bick and lrcik do not meet the specification
- [0] MIS_BICK_M
 - 0: FFX not muted
 - 1: FFX will be muted if bick is missing

FFXCFG2

| 7 | 6 | 5 | 4 | 3 | 2 | 1 | 0 |
|-------------|----------|-------------|---|------------|------------|----------|----------|
| RESET_NOISH | PWM_FREQ | NS_ORD[1:0] | | EA_TSFT_ON | CB_TSFT_ON | EA_PFDIG | CB_PFDIG |

Address: 0x02

Type: RW

Reset: 0x2D

Description:**[7] RESET_NOISH**

1: a reset is forced to the noise-shaper block

[6] PWM_FREQ

0: $4 f_S$ ($4 \cdot 96 \text{ kHz} = 384 \text{ kHz}$)

1: $8 f_S$ ($8 \cdot 96 \text{ kHz} = 768 \text{ kHz}$)

[5:4] NS_ORD[1:0]

Noise shape order

00: 3rd. order

01: 4th. order

10: 5th. order

[3] EA_TSFT_ON

1: if there is a fault on the external bridge, it will be put in 3-state

[2] CB_TSFT_ON

1: if there is a fault on the CMOS bridge, it will be put in 3-state

[1] EA_PFDIG

1: enable the pop-free ramp of EA

[0] CB_PFDIG

1: enable the pop-free ramp of CB

Note: *Particular care must be taken when bits NS_ORD and PWM_FREQ are changed. To avoid any audible artifacts, these bits must be modified only with the following procedure:*

1. Mute STA321 processing.
2. Change PWM_FREQ and/or NS_ORD and set RESET_NOISH = 1.
3. Configure RESET_NOISH = 0.
4. Unmute STA321 processing.

PWMMAP1**Processing to PWM out mapping**

| | | | | | | | |
|--------------|---|---|--------------|---|---|--------------|---|
| 7 | 6 | 5 | 4 | 3 | 2 | 1 | 0 |
| CB1_MAP[2:0] | | | CB2_MAP[2:0] | | | CB3_MAP[2:1] | |

Address: 0x03**Type:** RW**Reset:** 0x08**Description:**

[7:5] CB1_MAP[2:0]

CB_PWM_1 channel mapping:

000: Ch0-A

010: Ch1-A

100: Ch2-A

110: Ch3-A

001: Ch0-B

011: Ch1-B

101: Ch2-B

111: Ch3-B

[4:2] CB2_MAP[2:0]

CB_PWM_2 channel mapping

000: Ch0-A

010: Ch1-A

100: Ch2-A

110: Ch3-A

001: Ch0-B

011: Ch1-B

101: Ch2-B

111: Ch3-B

[1:0] CB3_MAP[2:1]

CB_PWM_3 channel mapping (for bit 0 see register [PWMMAP2](#)):

000: Ch0-A

010: Ch1-A

100: Ch2-A

110: Ch3-A

001: Ch0-B

011: Ch1-B

101: Ch2-B

111: Ch3-B

PWM MAP2

| | | | | | | | |
|------------|----------------|---|---|---------------|---|---|-------------|
| 7 | 6 | 5 | 4 | 3 | 2 | 1 | 0 |
| CB3_MAP[0] | PWM00_MAP[2:0] | | | EA1A_MAP[2:0] | | | EA1B_MAP[2] |

Address: 0x04**Type:** RW**Reset:** 0xB9**Description:****[7] CB3_MAP[0]**CB_PWM_3 channel mapping (for bits 1 and 2 see register [PWMMAP1](#))**[6:4] PWM00_MAP[2:0]**

PWM00 channel mapping:

| | |
|------------|------------|
| 000: Ch0-A | 001: Ch0-B |
| 010: Ch1-A | 011: Ch1-B |
| 100: Ch2-A | 101: Ch2-B |
| 110: Ch3-A | 111: Ch3-B |

[3:1] EA1A_MAP[2:0]

EA_PWM_1A channel mapping:

| | |
|------------|------------|
| 000: Ch0-A | 001: Ch0-B |
| 010: Ch1-A | 011: Ch1-B |
| 100: Ch2-A | 101: Ch2-B |
| 110: Ch3-A | 111: Ch3-B |

[0] EA1B_MAP[2]EA_PWM_1B channel mapping (for bits 1 and 0 see register [PWMMAP3](#))

| | |
|------------|------------|
| 000: Ch0-A | 001: Ch0-B |
| 010: Ch1-A | 011: Ch1-B |
| 100: Ch2-A | 101: Ch2-B |
| 110: Ch3-A | 111: Ch3-B |

PWMMAP3

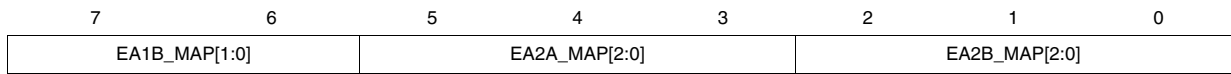

Address: 0x05

Type: RW

Reset: 0x77

Description:

- [7:6] **EA1B_MAP[1:0]**
EA_PWM_1B channel mapping (for bit 2 see register [PWMMAP2](#))
- [5:3] **EA2A_MAP[2:0]**
EA_PWM_2A channel mapping:

| | |
|------------|------------|
| 000: Ch0-A | 001: Ch0-B |
| 010: Ch1-A | 011: Ch1-B |
| 100: Ch2-A | 101: Ch2-B |
| 110: Ch3-A | 111: Ch3-B |
- [2:0] **EA2B_MAP[2:0]**
EA_PWM_2B channel mapping:

| | |
|------------|------------|
| 000: Ch0-A | 001: Ch0-B |
| 010: Ch1-A | 011: Ch1-B |
| 100: Ch2-A | 101: Ch2-B |
| 110: Ch3-A | 111: Ch3-B |

EATTF0

External bridge tristate time from fault

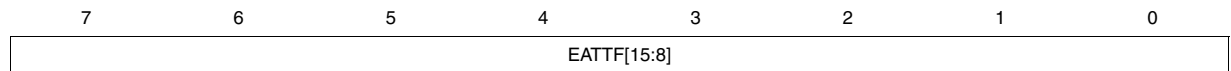

Address: 0x06

Type: RW

Reset: 0x00

Description: The tristate time is the time between fault deasserted and 3-state removed for the external bridge. It is calculated as EATTF[15:0] * 41.66 μs

- [7:0] **EATTF[15:8]**
MSBs of the EA tristate time factor

EATTF1 External bridge tristate time from fault

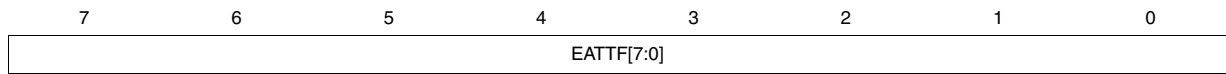

Address: 0x07
Type: RW
Reset: 0x03
Description: See also register [EATTF0](#)

[7:0] EATTF[7:0]
 LSBs of EA tristate time factor

EATTP0 External bridge tristate time from powerdown

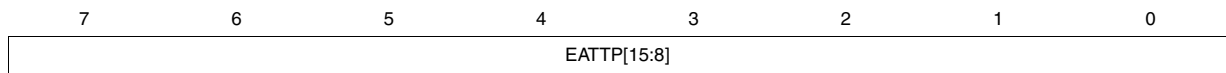

Address: 0x08
Type: RW
Reset: 0x00
Description: This tristate time is the time between bridge powerdown removed and 3-state removed for the external bridge. It is calculated as EATTP[15:0] * 41.66 μs

[7:0] EATTP[15:8]
 MSBs of EA 3-state time after power-up factor

EATTP1 External bridge tristate time from powerdown

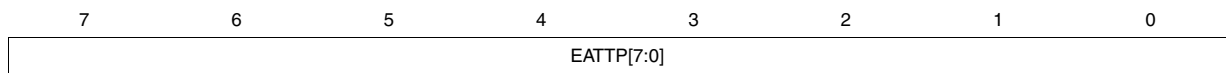

Address: 0x09
Type: RW
Reset: 0x03
Description: See also register [EATTP0](#)

[7:0] EATTP[7:0]
 LSBs of EA 3-state time after power-up factor

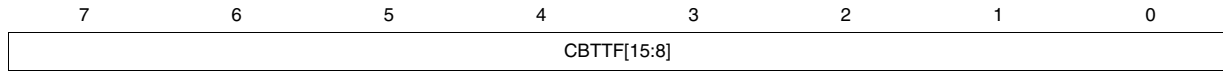
CBTTF0 **CMOS bridge tristate time from fault****Address:** 0x0A**Type:** RW**Reset:** 0x00**Description:** The tristate time is the time between fault deasserted and 3-state removed for the CMOS bridge. It is calculated as $CBTTF[15:0] * 41.66 \mu s$

[7:0] **CBTTF[15:8]**
MSBs of CB 3-state time factor

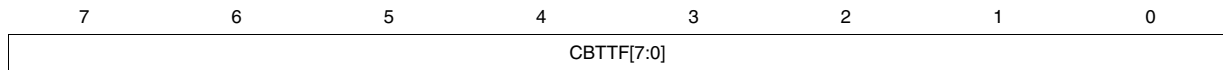
CBTTF1 **CMOS bridge tristate time from fault****Address:** 0x0B**Type:** RW**Reset:** 0x02**Description:** See also register [CBTTF0](#)

[7:0] **CBTTF[7:0]**
LSBs of CB 3-state time factor

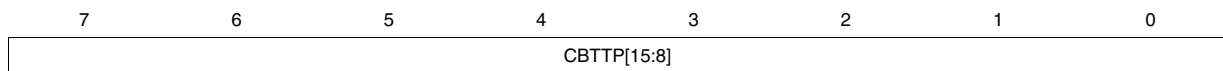
CBTTP0 **CMOS bridge tristate time from powerdown****Address:** 0x0C**Type:** RW**Reset:** 0x00**Description:** This tristate time is the time between bridge powerdown removed and 3-state removed for the CMOS bridge. It is calculated as $CBTTP[15:0] * 41.66 \mu s$

[7:0] **CBTTP[15:8]**
MSBs of CB 3-state time after power-up factor

CBTTP1 **CMOS bridge tristate time from powerdown**

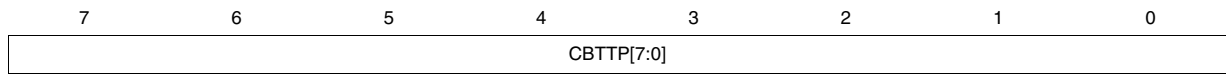

Address: 0x0D

Type: RW

Reset: 0x02

Description: See also register [CBTTP0](#)

[7:0] **CBTTP[7:0]**
LSBs of CB 3-state time after power-up factor

FFXST

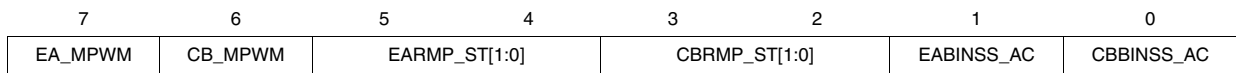

Address: 0x0E

Type: RO

Reset: 0xC0

Description:

- [7] **EA_MPWM**
1: EA is in mute
- [6] **CB_MPWM**
1: CB is in mute
- [5:4] **EARMP_ST[1:0]**: pop free ramp status
00: parked
11: ready
10: going to park
01: going to ready
- [3:2] **CBRMP_ST[1:0]**: pop free ramp status
00: parked
11: ready
10: going to park
01: going to ready
- [1] **EABINSS_AC**
1: ramp active (going to park or ready)
- [0] **CBBINSS_AC**
1: ramp active (going to park or ready)

POWST **Status register for external amplifier**

| | | | | | | | |
|----------|---|---|---|-------|-------|-------|-------|
| 7 | 6 | 5 | 4 | 3 | 2 | 1 | 0 |
| Reserved | | | | EA_TW | EA_PD | EA_FT | EA_TS |

Address: 0x0F

Type: RO

Reset: 0x05

Description:

- [7:4] **Reserved**
- [3] **EA_TW**
1: EA thermal warning
- [2] **EA_PD**
1: EA power-down
- [1] **EA_FT**
1: EA is in fault
- [0] **EA_TS**
1: EA is in 3-state

POWST1 **Status register for CMOS bridge**

| | | | | | | | |
|----------|-------|------------|---|---|------------|---|---|
| 7 | 6 | 5 | 4 | 3 | 2 | 1 | 0 |
| Reserved | CB_PD | CB_FT[2:0] | | | CB_TS[2:0] | | |

Address: 0x10

Type: RO

Reset: 0x47

Description:

- [7] **Reserved**
- [6] **CB_PD**
1: CMOS bridge is in power-down
- [5:3] **CB_FT[2:0]**
xx1: CMOS bridge channel 1 is in fault
x1x: CMOS bridge channel 2 is in fault
1xx: CMOS bridge channel 3 is in fault
- [2:0] **CB_TS[2:0]**
xx1: CMOS bridge channel 1 is in 3-state
x1x: CMOS bridge channel 2 is in 3-state
1xx: CMOS bridge channel 3 is in 3-state

PWMO1CFG0

| | | | | | | | |
|---------|-----------|---------|-----------|----------------|---|---|---|
| 7 | 6 | 5 | 4 | 3 | 2 | 1 | 0 |
| AZPLS_1 | TERNARY_1 | HALFB_1 | MP_ZERO_1 | MIN_PLS_1[3:0] | | | |

Address: 0x11

Type: RW

Reset: 0x20

Description:

- [7] AZPLS_1
1: avoid zero pulse
- [6] TERNARY_1
1: ternary modulation
- [5] HALFB_1
1: 1B is modulated as null signal
- [4] MP_ZERO_1
1: apply the minimum pulse settings also for values near 0
- [3:0] MIN_PLS_1[3:0]
minimum pulse length = clock period * (MIN_PLS_1 + 1)

PWMO1CFG1

| | | | | | | | |
|------------|---|------------|---|---|---|---|---|
| 7 | 6 | 5 | 4 | 3 | 2 | 1 | 0 |
| PM_1A[1:0] | | PS_1A[5:0] | | | | | |

Address: 0x12

Type: RW

Reset: 0x00

Description: Configuration for PWM-A

- [7:6] **PM_1A[1:0]:** PWM mode
00: generate a rising edge using a down carrier
01: generate a falling edge using an up carrier
10: hybrid mode: alternation of modes 00 and 01
11: hybrid mode: alternation of modes 01 and 00
- [5:0] PS_1A[5:0]: PWM shift
The PWM waveform could be shifted by (PS_1A * clock period / 64)

PWMO1CFG2

| | | | | | | | |
|------------|---|------------|---|---|---|---|---|
| 7 | 6 | 5 | 4 | 3 | 2 | 1 | 0 |
| PM_1B[1:0] | | PS_1B[5:0] | | | | | |

Address: 0x13
Type: RW
Reset: 0x48
Description: Configuration for PWM-B

- [7:6] PM_1B[1:0]: PWM mode
 - 00: generate a rising edge using a down carrier
 - 01: generate a falling edge using an up carrier
 - 10: ibrid mode: alternation of modes 00 and 01
 - 11: ibrid mode: alternation of modes 01 and 00
- [5:0] PS_1B[5:0]: PWM shift
 - The PWM waveform could be shifted by $(PS_1B * \text{clock period} / 64)$

PWMO2CFG0

| | | | | | | | |
|---------|-----------|---------|-----------|----------------|---|---|---|
| 7 | 6 | 5 | 4 | 3 | 2 | 1 | 0 |
| AZPLS_2 | TERNARY_2 | HALFB_2 | MP_ZERO_2 | MIN_PLS_2[3:0] | | | |

Address: 0x14
Type: RW
Reset: 0x20
Description:

- [7] AZPLS_2
 - 1: avoid zero pulse
- [6] TERNARY_2
 - 1: ternary modulation
- [5] HALFB_2
 - 1: 2B is modulated as null signal
- [4] MP_ZERO_2
 - 1: apply the minimum pulse settings also for values near 0
- [3:0] MIN_PLS_2[3:0]
 - Minimum pulse length = clock period * (MIN_PLS_2 + 1)

PWMO2CFG1

| | | | | | | | |
|------------|---|------------|---|---|---|---|---|
| 7 | 6 | 5 | 4 | 3 | 2 | 1 | 0 |
| PM_2A[1:0] | | PS_2A[5:0] | | | | | |

Address: 0x15

Type: RW

Reset: 0x10

Description:

- [7:6] **PM_2A[1:0]:** PWM mode
 - 00: generate a rising edge using a down carrier
 - 01: generate a falling edge using an up carrier
 - 10: hybrid mode: alternation of modes 00 and 01
 - 11: hybrid mode: alternation of modes 01 and 00
- [5:0] **PS_2A[5:0]:** PWM shift
 - The PWM waveform could be shifted by $(PS_2A * \text{clock period} / 64)$

PWMO2CFG2

| | | | | | | | |
|------------|---|------------|---|---|---|---|---|
| 7 | 6 | 5 | 4 | 3 | 2 | 1 | 0 |
| PM_2B[1:0] | | PS_2B[5:0] | | | | | |

Address: 0x16

Type: RW

Reset: 0x58

Description:

- [7:6] **PM_2B[1:0]:** PWM mode
 - 00: generate a rising edge using a down carrier
 - 01: generate a falling edge using an up carrier
 - 10: hybrid mode: alternation of modes 00 and 01
 - 11: hybrid mode: alternation of modes 01 and 00
- [5:0] **PS_2B[5:0]:** PWM shift
 - The PWM waveform could be shifted by $(PS_2B * \text{clock period} / 64)$

PWMO3CFG0

| | | | | | | | |
|---------|-----------|---------|-----------|----------------|---|---|---|
| 7 | 6 | 5 | 4 | 3 | 2 | 1 | 0 |
| AZPLS_3 | TERNARY_3 | HALFB_3 | MP_ZERO_3 | MIN_PLS_3[3:0] | | | |

Address: 0x17

Type: RW

Reset: 0x00

Description:

- [7] AZPLS_3
1: avoid zero pulse
- [6] TERNARY_3
1: ternary modulation
- [5] HALFB_3
1: 3B is modulated as null signal
- [4] MP_ZERO_3
1: apply the minimum pulse settings also for values near 0
- [3:0] MIN_PLS_3[3:0]
Minimum pulse length = clock period * (MIN_PLS_3 + 1)

PWMO3CFG1

| | | | | | | | |
|------------|---|------------|---|---|---|---|---|
| 7 | 6 | 5 | 4 | 3 | 2 | 1 | 0 |
| PM_3A[1:0] | | PS_3A[5:0] | | | | | |

Address: 0x18

Type: RW

Reset: 0x20

Description:

- [7:6] **PM_3A[1:0]:** PWM mode
00: generate a rising edge using a down carrier
01: generate a falling edge using an up carrier
10: hybrid mode: alternation of modes 00 and 01
11: hybrid mode: alternation of modes 01 and 00
- [5:0] PS_3A[5:0]: PWM shift
The PWM waveform could be shifted by (PS_3A * clock period / 64)

PWMO3CFG2

| | | | | | | | |
|------------|---|------------|---|---|---|---|---|
| 7 | 6 | 5 | 4 | 3 | 2 | 1 | 0 |
| PM_3B[1:0] | | PS_3B[5:0] | | | | | |

Address: 0x19

Type: RW

Reset: 0x68

Description:

- [7:6] **PM_3B[1:0]:** PWM mode
 - 00: generate a rising edge using a down carrier
 - 01: generate a falling edge using an up carrier
 - 10: hybrid mode: alternation of modes 00 and 01
 - 11: hybrid mode: alternation of modes 01 and 00
- [5:0] **PS_3B[5:0]:** PWM shift
 - The PWM waveform could be shifted by $(PS_3B * \text{clock period} / 64)$

PWMO4CFG0

| | | | | | | | |
|---------|-----------|---------|-----------|----------------|---|---|---|
| 7 | 6 | 5 | 4 | 3 | 2 | 1 | 0 |
| AZPLS_4 | TERNARY_4 | HALFB_4 | MP_ZERO_4 | MIN_PLS_4[3:0] | | | |

Address: 0x1A

Type: RW

Reset: 0x00

Description:

- [7] **AZPLS_4**
 - 1: avoid zero pulse
- [6] **TERNARY_4**
 - 1: ternary modulation
- [5] **HALFB_4**
 - 1: 4B is modulated as null signal
- [4] **MP_ZERO_4**
 - 1: apply the minimum pulse settings also for values near 0
- [3:0] **MIN_PLS_4[3:0]**
 - Minimum pulse length = clock period * (MIN_PLS_4 + 1)

PWMO4CFG1

| | | | | | | | |
|------------|---|------------|---|---|---|---|---|
| 7 | 6 | 5 | 4 | 3 | 2 | 1 | 0 |
| PM_4A[1:0] | | PS_4A[5:0] | | | | | |

Address: 0x1B**Type:** RW**Reset:** 0x30**Description:**[7:6] **PM_4A[1:0]:** PWM mode

00: generate a rising edge using a down carrier

01: generate a falling edge using an up carrier

10: hybrid mode: alternation of modes 00 and 01

11: hybrid mode: alternation of modes 01 and 00

[5:0] **PS_4A[5:0]:** PWM shiftThe PWM waveform could be shifted by $(PS_4A * \text{clock period} / 64)$ **PWMO4CFG2**

| | | | | | | | |
|------------|---|------------|---|---|---|---|---|
| 7 | 6 | 5 | 4 | 3 | 2 | 1 | 0 |
| PM_4B[1:0] | | PS_4B[5:0] | | | | | |

Address: 0x1C**Type:** RW**Reset:** 0x78**Description:**[7:6] **PM_4B[1:0]:** PWM mode

00: generate a rising edge using a down carrier

01: generate a falling edge using an up carrier

10: hybrid mode: alternation of modes 00 and 01

11: hybrid mode: alternation of modes 01 and 00

[5:0] **PS_4B[5:0]:** PWM shiftThe PWM waveform could be shifted by $(PS_4B * \text{clock period} / 64)$

CB_PFRAMP1

| | | | | | | | |
|---------------|---|---|---|---|---|----------|---|
| 7 | 6 | 5 | 4 | 3 | 2 | 1 | 0 |
| CBRMP_MP[5:0] | | | | | | Reserved | |

Address: 0x20**Type:** RW**Reset:** 0x14**Description:**

- [7:2] CBRMP_MP[5:0]
Minimum pulse width of the PDM signal
- [1:0] Reserved

CB_PFRAMP2

| | | | | | | | |
|----------------|---|---|---|---|---|---|---|
| 7 | 6 | 5 | 4 | 3 | 2 | 1 | 0 |
| CBRMPINI[15:8] | | | | | | | |

Address: 0x21**Type:** RW**Reset:** 0x80**Description:** Initial value of the ramp signal

- [7:0] CBRMPINI[15:8]
MSBs of CB ramp init

CB_PFRAMP3

| | | | | | | | |
|---------------|---|---|---|---|---|---|---|
| 7 | 6 | 5 | 4 | 3 | 2 | 1 | 0 |
| CBRMPINI[7:0] | | | | | | | |

Address: 0x22**Type:** RW**Reset:** 0x3C**Description:**

- [7:0] CBRMPINI[7:0]
LSBs of CB ramp init

CB_PFRAMP4

| | | | | | | | |
|----------------|---|---|---|----------|---|---|---|
| 7 | 6 | 5 | 4 | 3 | 2 | 1 | 0 |
| CBTIM_RMP[3:0] | | | | Reserved | | | |

Address: 0x23**Type:** RW**Reset:** 0x10**Description:**

- [7:4] CBTIM_RMP[3:0]
EA timing duration of the ramp (= slope)
- [3:0] Reserved

CB_PFRAMP5

| | | | | | | | |
|---------------|---|---|---|---|---|---|---|
| 7 | 6 | 5 | 4 | 3 | 2 | 1 | 0 |
| CBRMPTH[15:8] | | | | | | | |

Address: 0x24**Type:** RW**Reset:** 0x14**Description:** During the ramp, if the signal is below the threshold, the signal is modulated with PDM, otherwise with PWM

- [7:0] CBRMPH[15:8]
MSBs of CB ramp threshold

CB_PFRAMP6

| | | | | | | | |
|-------------|---|---|---|---|---|---|---|
| 7 | 6 | 5 | 4 | 3 | 2 | 1 | 0 |
| CBRMPH[7:0] | | | | | | | |

Address: 0x25**Type:** RW**Reset:** 0x00**Description:** During the ramp, if the signal is below the threshold, the signal is modulated with PDM, otherwise with PWM

- [7:0] CBRMPH[7:0]
LSBs of CB ramp threshold

EA_PFRAMP1

| | | | | | | | |
|---------------|---|---|---|---|---|----------|---|
| 7 | 6 | 5 | 4 | 3 | 2 | 1 | 0 |
| EARMP_MP[5:0] | | | | | | Reserved | |

Address: 0x26**Type:** RW**Reset:** 0x1C**Description:**

- [7:2] EARMP_MP[5:0]
Minimum pulse width of the PDM signal
- [1:0] Reserved

EA_PFRAMP2

| | | | | | | | |
|----------------|---|---|---|---|---|---|---|
| 7 | 6 | 5 | 4 | 3 | 2 | 1 | 0 |
| EARMPINI[15:8] | | | | | | | |

Address: 0x27**Type:** RW**Reset:** 0x80**Description:** Initial value of the ramp signal

- [7:0] EARMPINI[15:8]
MSBs of EA ramp init

EA_PFRAMP3

| | | | | | | | |
|---------------|---|---|---|---|---|---|---|
| 7 | 6 | 5 | 4 | 3 | 2 | 1 | 0 |
| EARMPINI[7:0] | | | | | | | |

Address: 0x28**Type:** RW**Reset:** 0x60**Description:**

- [7:0] EARMPINI[7:0]
LSBs of EA ramp init

EA_PFRAMP4

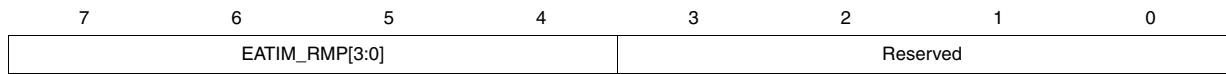

Address: 0x29

Type: RW

Reset: 0x10

Description:

- [7:4] EATIM_RMP[3:0]
EA timing duration of the ramp (= slope)
- [3:0] Reserved

EA_PFRAMP5

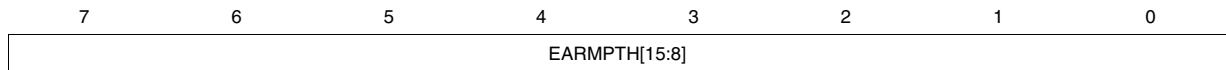

Address: 0x2A

Type: RW

Reset: 0x80

Description: During the ramp, if the signal is below the threshold, the signal is modulated with PDM, otherwise with PWM

- [7:0] EARMPTH[15:8]
MSBs of EA ramp threshold

EA_PFRAMP6



Address: 0x2B

Type: RW

Reset: 0x60

Description: During the ramp, if the signal is below the threshold, the signal is modulated with PDM, otherwise with PWM

- [7:0] EARMPTH[7:0]
LSBs of EA ramp threshold

SRC1STATE

| | | | | | | | |
|---------------|---|------------|-----------------|---|---|---|---|
| 7 | 6 | 5 | 4 | 3 | 2 | 1 | 0 |
| SRC1_BYP[1:0] | | SRC_1_LOCK | SRC1_FISFO[4:0] | | | | |

Address: 0x30
Type: RO
Reset: 0x8F
Description: Values of f_S based on the 96 kHz as output frequency

- [7:6] SRC1_BYP[1:0]
 00: input signal has $f_S < 78$ kHz
 10: input signal has $f_S > 81$ kHz
- [5] SRC_1_LOCK
 0: SRC target frequency not reached
 1: SRC1 target frequency reached
- [4:0] SRC1_FISFO[4:0]
 MSB Fs_{input} / Fs_{output}

SRC2STATE

| | | | | | | | |
|---------------|---|------------|-----------------|---|---|---|---|
| 7 | 6 | 5 | 4 | 3 | 2 | 1 | 0 |
| SRC1_BYP[1:0] | | SRC_1_LOCK | SRC1_FISFO[4:0] | | | | |

Address: 0x31
Type: RO
Reset: 0x8F
Description:

- [7:6] SRC2_BYP[1:0]
 00: Input Signal has $f_S < 78$ kHz
 10: Input Signal has $f_S > 81$ kHz
- [5] SRC_2_LOCK
 0: SRC target frequency not reached
 1: SRC1 target frequency reached
- [4:0] SRC2_FISFO[4:0]
 MSB Fs_{input} / Fs_{output}

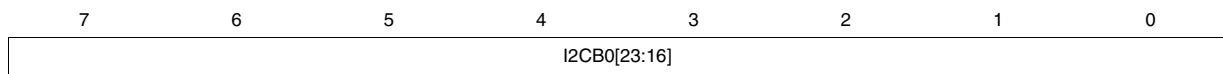
I2CB0_TOP**Address:** 0x51**Type:** RW**Reset:** 0x00**Description:**

[7:0] I2CB0[23:16]
MSBs of coefficient b0

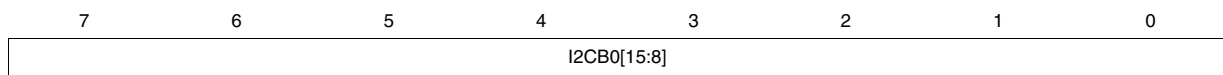
I2CB0_MID**Address:** 0x52**Type:** RW**Reset:** 0x00**Description:**

[7:0] I2CB0[15:8]
Middle bits of coefficient b0

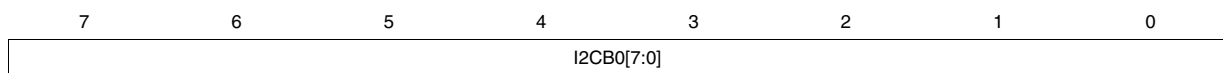
I2CB0_BOT**Address:** 0x53**Type:** RW**Reset:** 0x00**Description:**

[7:0] I2CB0[7:0]
LSBs of coefficient b0

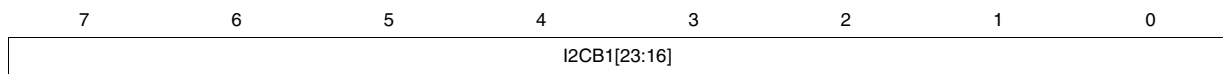
I2CB1_TOP**Address:** 0x54**Type:** RW**Reset:** 0x00**Description:**

[7:0] I2CB1[23:16]
MSBs of coefficient b1

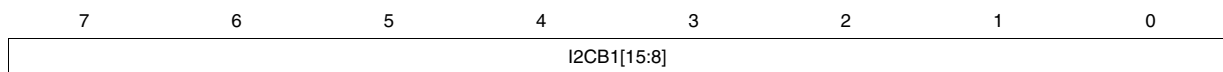
I2CB1_MID**Address:** 0x55**Type:** RW**Reset:** 0x00**Description:**

[7:0] I2CB1[15:8]
Middle bits of coefficient b1

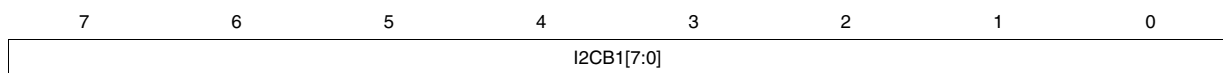
I2CB1_BOT**Address:** 0x56**Type:** RW**Reset:** 0x00**Description:**

[7:0] I2CB1[7:0]
LSBs of coefficient b1

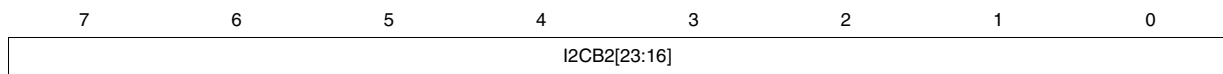
I2CB2_TOP**Address:** 0x57**Type:** RW**Reset:** 0x00**Description:**

[7:0] I2CB2[23:16]
MSBs of coefficient b2

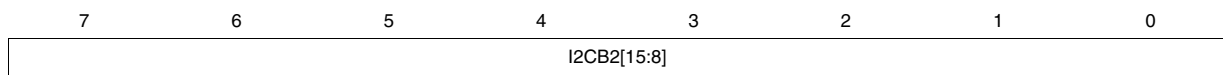
I2CB2_MID**Address:** 0x58**Type:** RW**Reset:** 0x00**Description:**

[7:0] I2CB2[15:8]
Middle bits of coefficient b2

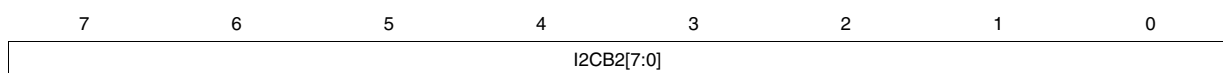
I2CB2_BOT**Address:** 0x59**Type:** RW**Reset:** 0x00**Description:**

[7:0] I2CB2[7:0]
LSBs of coefficient b2

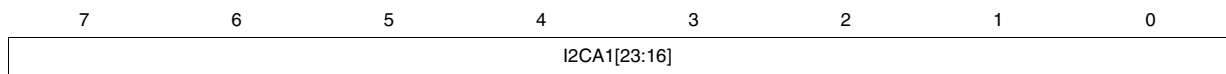
I2CA1_TOP**Address:** 0x5A**Type:** RW**Reset:** 0x00**Description:**

[7:0] I2CA1[23:16]
MSBs of coefficient a1

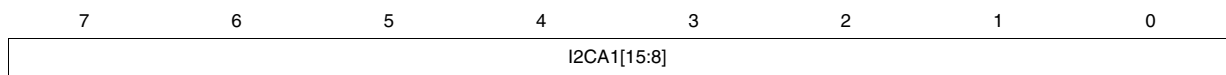
I2CA1_MID**Address:** 0x5B**Type:** RW**Reset:** 0x00**Description:**

[7:0] I2CA1[15:8]
Middle bits of coefficient a1

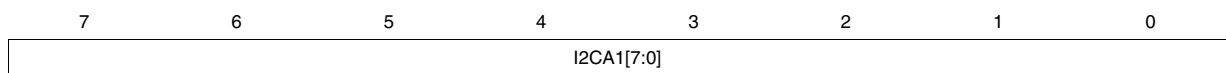
I2CA1_BOT**Address:** 0x5C**Type:** RW**Reset:** 0x00**Description:**

[7:0] I2CA1[7:0]
LSBs of coefficient a1

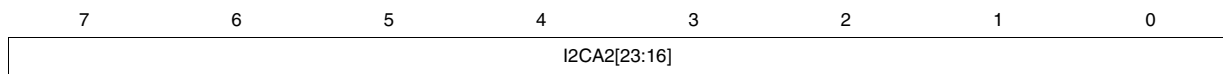
I2CA2_TOP**Address:** 0x5D**Type:** RW**Reset:** 0x00**Description:**

[7:0] I2CA2[23:16]
MSBs of coefficient a2

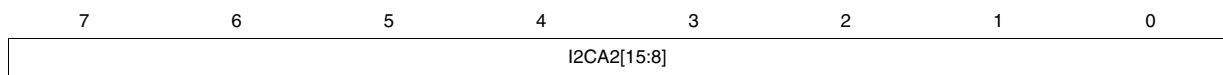
I2CA2_MID**Address:** 0x5E**Type:** RW**Reset:** 0x00**Description:**

[7:0] I2CA2[15:8]
Middle bits of coefficient a2

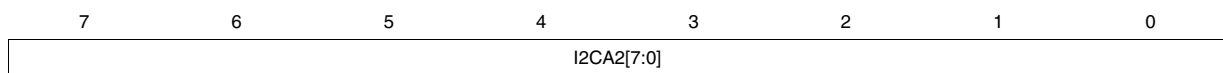
I2CA2_BOT**Address:** 0x5F**Type:** RW**Reset:** 0x00**Description:**

[7:0] I2CA2[7:0]
LSBs of coefficient a2

PROCCTRL

| | | | | | | | |
|----------|---|---|---|----|----------|----|----|
| 7 | 6 | 5 | 4 | 3 | 2 | 1 | 0 |
| Reserved | | | | RA | Reserved | WA | W1 |

Address: 0x60**Type:** RO**Reset:** 0x00**Description:**[7:4] **Reserved**

[3] RA

1: read all the biquad coefficients

[2] Reserved

[1] WA

1: write/update all the biquad coefficients

[0] W1

1: write/update the b0 coefficient

START_ADDR2

| | | | | | | | |
|----------|---|---|---|---|---|---|-------------|
| 7 | 6 | 5 | 4 | 3 | 2 | 1 | 0 |
| Reserved | | | | | | | I2CSTART_A8 |

Address: 0x61**Type:** RW**Reset:** 0x00**Description:**

[7:1] Reserved

[0] I2CSTART_A8

Base address of the biquadratic to be updated (= address of coefficient b0)

START_ADDR1

| | | | | | | | |
|----------------|---|---|---|---|---|---|---|
| 7 | 6 | 5 | 4 | 3 | 2 | 1 | 0 |
| I2CSTART_A7_A0 | | | | | | | |

Address: 0x62**Type:** RW**Reset:** 0x00**Description:**

[7:0] I2CSTART_A7_A0

Base address of the biquadratic to be updated (= address of the b0 coefficient)

ROM_REMAP

| | | | | | | | |
|----------|-----------|-----------|-----------|-----------|-----------|------------|------------|
| 7 | 6 | 5 | 4 | 3 | 2 | 1 | 0 |
| Reserved | ENAB_PRE3 | ENAB_PRE2 | ENAB_PRE1 | ENAB_PRE0 | ENAB_POST | ENAB_PRMIX | ENAB_DELAY |

Address: 0x6F**Type:** RW**Reset:** 0x00**Description:**[7] **Reserved**

[6] ENAB_PRE3

0: pre scale value of channel 3 taken from RAM
1: pre scale value of channel 3 taken from ROM

[5] ENAB_PRE2

0: pre scale value of channel 2 taken from RAM
1: pre scale value of channel 2 taken from ROM

[4] ENAB_PRE1

0: pre scale value of channel 1 taken from RAM
1: pre scale value of channel 1 taken from ROM

[3] ENAB_PRE0

0: pre scale value of channel 0 taken from RAM
1: pre scale value of channel 0 taken from ROM

[2] ENAB_POST

0: post mix values taken from RAM
1: post mix values taken from ROM

[1] ENAB_PRMIX

0: pre mix values taken from RAM
1: pre mix values taken from ROM

[0] ENAB_DELAY

0: Delay values taken from RAM
1: Delay values taken from ROM

BYP_EN_CH0

| | | | | | | | |
|----------|---|---|---|---|---|---|---|
| 7 | 6 | 5 | 4 | 3 | 2 | 1 | 0 |
| Reserved | | | | | | | |

Address: 0x70**Type:** RW**Reset:** 0x00**Description:**[7:0] **Reserved****EFFS_EN_CH0**

| | | | | | | | |
|----------|---|---|---|---|---|--------|--------|
| 7 | 6 | 5 | 4 | 3 | 2 | 1 | 0 |
| Reserved | | | | | | EROM09 | EROM08 |

Address: 0x71**Type:** RW**Reset:** 0x00**Description:**[7:2] **Reserved**[1] EROM09
1: enable de-emphasis EQ on channel 0[0] EROM08
1: enable high-pass filter on channel 0**BYP_EN_CH1**

| | | | | | | | |
|----------|---|---|---|---|---|---|---|
| 7 | 6 | 5 | 4 | 3 | 2 | 1 | 0 |
| Reserved | | | | | | | |

Address: 0x72**Type:** RW**Reset:** 0x00**Description:**[7:0] **Reserved**

EFFS_EN_CH1

| | | | | | | | |
|----------|---|---|---|---|---|--------|----------|
| 7 | 6 | 5 | 4 | 3 | 2 | 1 | 0 |
| Reserved | | | | | | EROM19 | Reserved |

Address: 0x73

Type: RW

Reset: 0x00

Description:

- [7:2] **Reserved**
- [1] EROM19
1: enable de-emphasis EQ on channel 1
- [0] Reserved

BYP_EN_CH2

| | | | | | | | |
|----------|---|---|---|---|---|---|---|
| 7 | 6 | 5 | 4 | 3 | 2 | 1 | 0 |
| Reserved | | | | | | | |

Address: 0x74

Type: RW

Reset: 0x00

Description:

- [7:0] Reserved

EFFS_EN_CH2

| | | | | | | | |
|----------|---|---|---|---|---|--------|--------|
| 7 | 6 | 5 | 4 | 3 | 2 | 1 | 0 |
| Reserved | | | | | | EROM29 | EROM28 |

Address: 0x75

Type: RW

Reset: 0x00

Description:

- [7:2] **Reserved**
- [1] EROM29
1: enable de-emphasis EQ on channel 2
- [0] EROM28
1: enable high-pass filter on channel 2

BYP_EN_CH3

| | | | | | | | |
|----------|---|---|---|---|---|---|---|
| 7 | 6 | 5 | 4 | 3 | 2 | 1 | 0 |
| Reserved | | | | | | | |

Address: 0x76

Type: RW

Reset: 0x00

Description:

[7:0] **Reserved**

EFFS_EN_CH3

| | | | | | | | |
|----------|---|---|---|---|---|--------|----------|
| 7 | 6 | 5 | 4 | 3 | 2 | 1 | 0 |
| Reserved | | | | | | EROM39 | Reserved |

Address: 0x77

Type: RW

Reset: 0x00

Description:

[7:2] **Reserved**

[1] EROM39

1: enable de-emphasis EQ on channel 3

[0] **Reserved**

BASS_SELO_R

| | | | | | | | |
|----------|---|----------|-----------|---|---|---|---|
| 7 | 6 | 5 | 4 | 3 | 2 | 1 | 0 |
| Reserved | | BASS_EN0 | BASS_SELO | | | | |

Address: 0x78

Type: RW

Reset: 0x00

Description:

[7:6] **Reserved**

[5] BASS_EN0

0: Bass EQ of channel 0 is not active

1: Bass EQ of channel 0 is active

[4:0] BASS_SELO

Select the gain of the bass filter from -12 dB (00000) to +12 dB using [Table 35](#) below

BASS_SEL1_R

| | | | | | | | |
|----------|---|-----------|---|---|---|---|---|
| 7 | 6 | 5 | 4 | 3 | 2 | 1 | 0 |
| Reserved | | BASS_EN1 | | | | | |
| | | BASS_SEL1 | | | | | |

Address: 0x79**Type:** RW**Reset:** 0x00**Description:**

[7:6] Reserved

[5] BASS_EN1

0: Bass EQ of channel 1 is not active

1: Bass EQ of channel 1 is active

[4:0] BASS_SEL1

Select the gain of the bass filter from -12 dB (00000) to +12 dB using [Table 35](#) below**BASS_SEL2_R**

| | | | | | | | |
|----------|---|-----------|---|---|---|---|---|
| 7 | 6 | 5 | 4 | 3 | 2 | 1 | 0 |
| Reserved | | BASS_EN2 | | | | | |
| | | BASS_SEL2 | | | | | |

Address: 0x7A**Type:** RW**Reset:** 0x00**Description:**

[7:6] Reserved

[5] BASS_EN2

0: Bass EQ of channel 2 is not active

1: Bass EQ of channel 2 is active

[4:0] BASS_SEL2

Select the gain of the bass filter from -12 dB (00000) to +12 dB using [Table 35](#) below

BASS_SEL3_R

| | | | | | | | |
|----------|---|----------|-----------|---|---|---|---|
| 7 | 6 | 5 | 4 | 3 | 2 | 1 | 0 |
| Reserved | | BASS_EN3 | BASS_SEL3 | | | | |

Address: 0x7B**Type:** RW**Reset:** 0x00**Description:**

[7:6] Reserved

[5] BASS_EN3

0: Bass EQ of channel 3 is not active

1: Bass EQ of channel 3 is active

[4:0] BASS_SEL3

Select the gain of the bass filter from -12 dB (00000) to +12 dB using [Table 35](#) below**TREB_SELO_R**

| | | | | | | | |
|----------|---|----------|-----------|---|---|---|---|
| 7 | 6 | 5 | 4 | 3 | 2 | 1 | 0 |
| Reserved | | TREB_EN0 | TREB_SELO | | | | |

Address: 0x7C**Type:** RW**Reset:** 0x00**Description:**

[7:6] Reserved

[5] TREB_EN0

0: Treble EQ of channel 0 is not active

1: Treble EQ of channel 0 is active

[4:0] TREB_SELO

Select the gain of the treble filter from -12 dB (00000) to +12 dB using [Table 35](#) below

TREB_SEL1_R

| | | | | | | | |
|----------|---|-----------|---|---|---|---|---|
| 7 | 6 | 5 | 4 | 3 | 2 | 1 | 0 |
| Reserved | | TREB_EN1 | | | | | |
| | | TREB_SEL1 | | | | | |

Address: 0x7D

Type: RW

Reset: 0x00

Description:

- [7:6] Reserved
- [5] TREB_EN1
 - 0: Treble EQ of channel 1 is not active
 - 1: Treble EQ of channel 1 is active
- [4:0] TREB_SEL1
 - Select the gain of the treble filter from -12 dB (00000) to +12 dB using [Table 35](#) below

TREB_SEL2_R

| | | | | | | | |
|----------|---|-----------|---|---|---|---|---|
| 7 | 6 | 5 | 4 | 3 | 2 | 1 | 0 |
| Reserved | | TREB_EN2 | | | | | |
| | | TREB_SEL2 | | | | | |

Address: 0x7E

Type: RW

Reset: 0x00

Description:

- [7:6] Reserved
- [5] TREB_EN2
 - 0: Treble EQ of channel 2 is not active
 - 1: Treble EQ of channel 2 is active
- [4:0] TREB_SEL2
 - Select the gain of the treble filter from -12 dB (00000) to +12 dB using [Table 35](#) below

TREB_SEL3_R

| | | | | | | | |
|-----------|---|----------|---|---|---|---|---|
| 7 | 6 | 5 | 4 | 3 | 2 | 1 | 0 |
| Reserved | | TREB_EN3 | | | | | |
| TREB_SEL3 | | | | | | | |

Address: 0x7F

Type: RW

Reset: 0x00

Description:

[7:6] Reserved

[5] TREB_EN3

0: Treble EQ of channel 3 is not active

1: Treble EQ of channel 3 is active

[4:0] TREB_SEL3

Select the gain of the treble filter from -12 dB (00000) to +12 dB using [Table 35](#) below

Table 35. Bass/treble filter gains used in register addresses 0x78 - 0x7F

| BASS_SELx TREBLE_SELx | Gain | BASS_SELx TREBLE_SELx | Gain |
|--------------------------|------|--------------------------|------|
| 11000 | +12 | - | - |
| 10111 | +11 | 01011 | -01 |
| 10110 | +10 | 01010 | -02 |
| 10101 | +09 | 01001 | -03 |
| 10100 | +08 | 01000 | -04 |
| 10011 | +07 | 00111 | -05 |
| 10010 | +06 | 00110 | -06 |
| 10001 | +05 | 00101 | -07 |
| 10000 | +04 | 00100 | -08 |
| 01111 | +03 | 00011 | -09 |
| 01110 | +02 | 00010 | -10 |
| 01101 | +01 | 00001 | -11 |
| 01100 | +00 | 00000 | -12 |

SATCH0CFG1

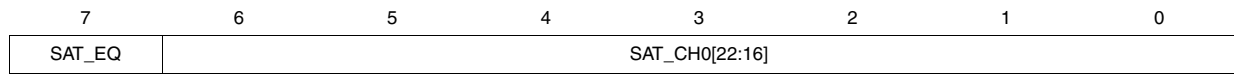

Address: 0x90

Type: RW

Reset: 0xFF

Description:

- [7] SAT_EQ
 - 0: saturation value of every channel is independent
 - 1: all the channels take the saturation value of channel 0
- [6:0] SAT_CH0[22:16]
 - MSBs of the absolute saturation value for channel 0.
 - If the signal is above SAT_CH0[22:0] then it is truncated

SATCH0CFG2

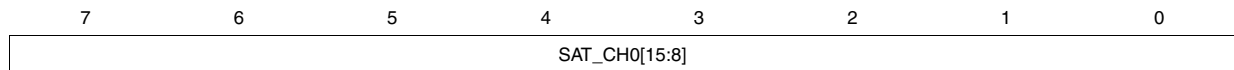

Address: 0x91

Type: RW

Reset: 0xFF

Description:

- [7:0] SAT_CH0[15:8]
 - Middle bits of the saturation value for channel 0
 - If the signal is above SAT_CH0[22:0] then it is truncated

SATCH0CFG3

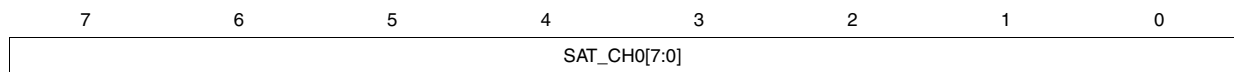

Address: 0x92

Type: RW

Reset: 0xFF

Description:

- [7:0] SAT_CH0[7:0]
 - LSBs of the saturation value for channel 0
 - If the signal is above SAT_CH0[22:0] then it is truncated

SATCH1CFG1

| | | | | | | | |
|----------|----------------|---|---|---|---|---|---|
| 7 | 6 | 5 | 4 | 3 | 2 | 1 | 0 |
| Reserved | SAT_CH1[22:16] | | | | | | |

Address: 0x93

Type: RW

Reset: 0x00

Description:

[7] Reserved

[6:0] SAT_CH1[22:16]

MSBs of the absolute saturation value for channel 1.

If the signal is above SAT_CH1[22:0] then it is truncated, see also register bit [SATCH0CFG1\[7\]](#)

SATCH1CFG2

| | | | | | | | |
|---------------|---|---|---|---|---|---|---|
| 7 | 6 | 5 | 4 | 3 | 2 | 1 | 0 |
| SAT_CH1[15:8] | | | | | | | |

Address: 0x94

Type: RW

Reset: 0x00

Description:

[7:0] SAT_CH1[15:8]

Middle bits of the saturation value for channel 1

If the signal is above SAT_CH1[22:0] then it is truncated, see also register bit [SATCH0CFG1\[7\]](#)

SATCH1CFG3

| | | | | | | | |
|--------------|---|---|---|---|---|---|---|
| 7 | 6 | 5 | 4 | 3 | 2 | 1 | 0 |
| SAT_CH1[7:0] | | | | | | | |

Address: 0x95

Type: RW

Reset: 0x00

Description:

[7:0] SAT_CH1[7:0]

LSBs of the saturation value for channel 1

If the signal is above SAT_CH1[22:0] then it is truncated, see also register bit [SATCH0CFG1\[7\]](#)

SATCH2CFG1

| | | | | | | | |
|----------|----------------|---|---|---|---|---|---|
| 7 | 6 | 5 | 4 | 3 | 2 | 1 | 0 |
| Reserved | SAT_CH2[22:16] | | | | | | |

Address: 0x96**Type:** RW**Reset:** 0x00**Description:**

[7] Reserved

[6:0] SAT_CH2[22:16]

MSBs of the absolute saturation value for channel 2.

If the signal is above SAT_CH2[22:0] then it is truncated, see also register bit [SATCH0CFG1](#)[7]**SATCH2CFG2**

| | | | | | | | |
|---------------|---|---|---|---|---|---|---|
| 7 | 6 | 5 | 4 | 3 | 2 | 1 | 0 |
| SAT_CH2[15:8] | | | | | | | |

Address: 0x97**Type:** RW**Reset:** 0x00**Description:**

[7:0] SAT_CH2[15:8]

Middle bits of the saturation value for channel 2

If the signal is above SAT_CH2[22:0] then it is truncated, see also register bit [SATCH0CFG1](#)[7]**SATCH2CFG3**

| | | | | | | | |
|--------------|---|---|---|---|---|---|---|
| 7 | 6 | 5 | 4 | 3 | 2 | 1 | 0 |
| SAT_CH2[7:0] | | | | | | | |

Address: 0x98**Type:** RW**Reset:** 0x00**Description:**

[7:0] SAT_CH2[7:0]

LSBs of the saturation value for channel 2

If the signal is above SAT_CH2[22:0] then it is truncated, see also register bit [SATCH0CFG1](#)[7]

SATCH3CFG1

| | | | | | | | |
|----------|----------------|---|---|---|---|---|---|
| 7 | 6 | 5 | 4 | 3 | 2 | 1 | 0 |
| Reserved | SAT_CH3[22:16] | | | | | | |

Address: 0x99

Type: RW

Reset: 0x00

Description:

[7] Reserved

[6:0] SAT_CH3[22:16]

MSBs of the absolute saturation value for channel 3.

If the signal is above SAT_CH3[22:0] then it is truncated, see also register bit [SATCH0CFG1\[7\]](#)

SATCH3CFG2

| | | | | | | | |
|---------------|---|---|---|---|---|---|---|
| 7 | 6 | 5 | 4 | 3 | 2 | 1 | 0 |
| SAT_CH3[15:8] | | | | | | | |

Address: 0x9A

Type: RW

Reset: 0x00

Description:

[7:0] SAT_CH3[15:8]

Middle bits of the saturation value for channel 3

If the signal is above SAT_CH3[22:0] then it is truncated, see also register bit [SATCH0CFG1\[7\]](#)

SATCH3CFG3

| | | | | | | | |
|--------------|---|---|---|---|---|---|---|
| 7 | 6 | 5 | 4 | 3 | 2 | 1 | 0 |
| SAT_CH3[7:0] | | | | | | | |

Address: 0x9B

Type: RW

Reset: 0x00

Description:

[7:0] SAT_CH3[7:0]

LSBs of the saturation value for channel 3

If the signal is above SAT_CH3[22:0] then it is truncated, see also register bit [SATCH0CFG1\[7\]](#)

VOLCFG

| | | | | | | | |
|----------|----------|----------|----------|----------|---|---|---|
| 7 | 6 | 5 | 4 | 3 | 2 | 1 | 0 |
| SVOL_ON3 | SVOL_ON2 | SVOL_ON1 | SVOL_ON0 | TIM_SVOL | | | |

Address: 0xA0
Type: RW
Reset: 0xF5
Description: The register sets up the soft volume control

- [7] SVOL_ON3
 0: volume on channel 3 is updated immediately
 1: volume on channel 3 is updated gradually with a ramp
- [6] SVOL_ON2
 0: volume on channel 2 is updated immediately
 1: volume on channel 2 is updated gradually with a ramp
- [5] SVOL_ON1
 0: volume on channel 1 is updated immediately
 1: volume on channel 1 is updated gradually with a ramp
- [4] SVOL_ON0
 0: volume on channel 0 is updated immediately
 1: volume on channel 0 is updated gradually with a ramp
- [3:0] TIM_SVOL
 Set the volume ramp; each volume step (0.5 dB) takes $(2^{TIM_SVOL} / f_S)$ s

MVOL **Master volume control**

| | | | | | | | |
|------|---|---|---|---|---|---|---|
| 7 | 6 | 5 | 4 | 3 | 2 | 1 | 0 |
| MVOL | | | | | | | |

Address: 0xA1
Type: RW
Reset: 0x00
Description:

- [7:0] MVOL
 Master volume from 0 dB to -127.5 dB in 0.5 dB steps (volume = MVOL * 0.5 dB)

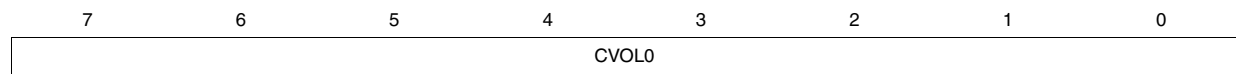
VOLCH0 **Channel 0 volume control****Address:** 0xA2**Type:** RW**Reset:** 0x48**Description:**

[7:0] CVOL0
Channel 0 volume 36 dB to -91.5 dB in 0.5 dB steps

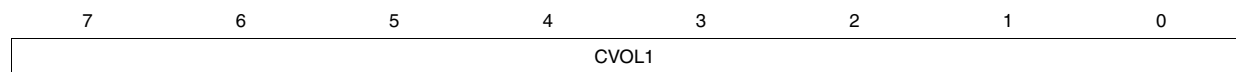
VOLCH1 **Channel 1 volume control****Address:** 0xA3**Type:** RW**Reset:** 0x48**Description:**

[7:0] CVOL1
Channel 1 volume 36 dB to -91.5 dB in 0.5 dB steps

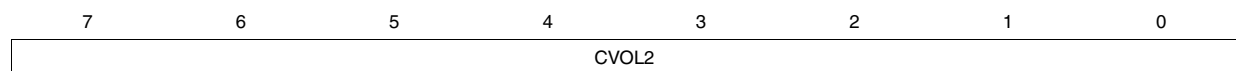
VOLCH2 **Channel 2 volume control****Address:** 0xA4**Type:** RW**Reset:** 0x48**Description:**

[7:0] CVOL2
Channel 2 volume 36 dB to -91.5 dB in 0.5 dB steps

VOLCH3 Channel 3 volume control

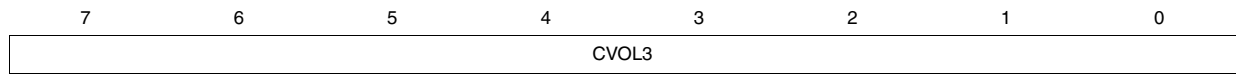

Address: 0xA5

Type: RW

Reset: 0x48

Description:

[7:0] CVOL3
Channel 3 volume 36 dB to -91.5 dB in 0.5 dB steps

SAI_IN1_CFG0

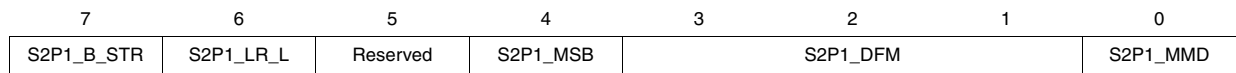

Address: 0xB0

Type: RW

Reset: 0xD2

Description:

- [7] S2P1_B_STR
BICKLK strobe
0: active_edge = rising, strb_edge = falling
1: active_edge = falling, strb_edge = rising
- [6] S2P1_LR_L
LRCLK strobe
0: left = 0, right = 1
1: left = 1, right = 0
- [5] Reserved
- [4] S2P1_MSB
MSB first
- [3:1] S2P1_DFM[2:0]
Data format
000: left justified
001: I²S
010: right justified
100: PCM no-delay
101: PCM delay
111: DSP
- [0] S2P1_MMD
Master mode

SAI_IN1_CFG1

| | | | | | | | |
|-----------|---|----------|---|------------|---|------------|---|
| 7 | 6 | 5 | 4 | 3 | 2 | 1 | 0 |
| S2P1_DLEN | | S2P1_BOS | | S2P1_MAP_L | | S2P1_MAP_R | |

Address: 0xB1**Type:** RW**Reset:** 0x91**Description:**

[7:6] S2P1_DLEN

Data length

00: 8 bits

01: 16 bits

10: 24 bits

11: 32 bits

[5:4] S2P1_BOS

BICKL_OS

00: BICKL = 32 * f_S01: BICKL = 64 * f_S10: BICKL = 128 * f_S11: BICKL = 256 * f_S

[3:2] S2P1_MAP_L

Map left

00: slot 0

01: slot 1

10: slot 2

11: slot 3

[1:0] S2P1_MAP_R

Map right

00: slot 0

01: slot 1

10: slot 2

11: slot 3

SAI_OUT_CFG0

| 7 | 6 | 5 | 4 | 3 | 2 | 1 | 0 |
|-----------|----------|------------|---------|---------|---|---------|---|
| P2S_B_STR | P2S_LR_L | SDATA0_ACT | P2S_MSB | P2S_DFM | | P2S_MMD | |

Address: 0xB2**Type:** RW**Reset:** 0xD3**Description:**

- [7] P2S_B_STR
BICKLK strobe
0: active_edge = rising, strb_edge = falling
1: active_edge = falling, strb_edge = rising
- [6] P2S_LR_L
LRCLK strobe
0: left = 0, right = 1
1: left = 1, right = 0
- [5] SDATA0_ACT
0: normal behavior
1: SDATA0 is disabled
- [4] P2S_MSB
MSB first
- [3:1] P2S_DFM[2:0]
Data format
000: left justified
001: I²S
010: right justified
100: PCM no-delay
101: PCM delay
111: DSP
- [0] P2S_MMD
Master mode

SAI_OUT_CFG1

| | | | | | | | |
|----------|---|---------|---|-----------|---|-----------|---|
| 7 | 6 | 5 | 4 | 3 | 2 | 1 | 0 |
| P2S_DLEN | | P2S_BOS | | P2S_MAP_L | | P2S_MAP_R | |

Address: 0xB3**Type:** RW**Reset:** 0x91**Description:**

[7:6] P2S_DLEN

Data length

00: 08 bits

01: 16 bits

10: 24 bits

11: 32 bits

[5:4] P2S_BOS

BICKL_OS

00: BICKL = 32 * f_S 01: BICKL = 64 * f_S 10: BICKL = 128 * f_S 11: BICKL = 256 * f_S

[3:2] P2S_MAP_L

Map left

00: slot 0

01: slot 1

10: slot 2

11: slot 3

[1:0] P2S_MAP_R

Map right

00: slot 0

01: slot 1

10: slot 2

11: slot 3

SAI_IN2_CFG0

| | | | | | | | |
|------------|-----------|----------|----------|----------|---|---|----------|
| 7 | 6 | 5 | 4 | 3 | 2 | 1 | 0 |
| S2P2_B_STR | S2P2_LR_L | Reserved | S2P2_MSB | S2P2_DFM | | | S2P2_MMD |

Address: 0xB4**Type:** RW**Reset:** 0xD2**Description:**

- [7] S2P2_B_STR
BICKLK strobe
0: active_edge = rising, strb_edge = falling
1: active_edge = falling, strb_edge = rising
- [6] S2P2_LR_L
LRCLK strobe
0: left = 0, right = 1
1: left = 1, right = 0
- [5] Reserved
- [4] S2P2_MSB
MSB first
- [3:1] S2P2_DFM[2:0]
Data format
000: left justified
001: I²S
010: right justified
100: PCM no-delay
101: PCM delay
111: DSP
- [0] S2P2_MMD
Master mode

SAI_IN2_CFG1

| | | | | | | | |
|-----------|---|----------|---|------------|---|------------|---|
| 7 | 6 | 5 | 4 | 3 | 2 | 1 | 0 |
| S2P2_DLEN | | S2P2_BOS | | S2P2_MAP_L | | S2P2_MAP_R | |

Address: 0xB5**Type:** RW**Reset:** 0x91**Description:****[7:6] S2P2_DLEN**

Data length

00: 8 bits

01: 16 bits

10: 24 bits

11: 32 bits

[5:4] S2P2_BOS

BICKL_OS

00: BICKL = 32 * f_S01: BICKL = 64 * f_S10: BICKL = 128 * f_S11: BICKL = 256 * f_S**[3:2] S2P2_MAP_L**

Map left

00: slot 0

01: slot 1

10: slot 2

11: slot 3

[1:0] S2P2_MAP_R

Map right

00: slot 0

01: slot 1

10: slot 2

11: slot 3

AUIFSHARE

| | | | | | | | |
|----------|---|---|---|---|---|------------|---|
| 7 | 6 | 5 | 4 | 3 | 2 | 1 | 0 |
| Reserved | | | | | | SHARE_BILR | |

Address: 0xB6**Type:** RW**Reset:** 0x00**Description:**

[7:2] Reserved

[1:0] SHARE_BILR

00: no clock sharing

01: SAI_in1, SAI_in2 share the clocks: BICKI1 and LRCLKI1 (others are not used)

SAI1: can be master/slave (see config)

SAI2: always slave

10: SAI_in1, SAI_in2, SAI_out share the clocks: BICKI1 and LRCLKI1 (others are not used)

SAI_out: can be master/slave (see config)

SAI1 and SAI2: always slave

11: no clock sharing

SRCINSEL

| | | | | | | | |
|------------|---|------------|---|-----------|----------|---|---|
| 7 | 6 | 5 | 4 | 3 | 2 | 1 | 0 |
| SRC1_INSEL | | SRC2_INSEL | | MUTE_SRCU | Reserved | | |

Address: 0xB7**Type:** RW**Reset:** 0x28**Description:**

[7:6] SRC1_INSEL

Sample rate converter IN channels 0 and 1:

00: serial audio interface IN 1

01: ADC

1x: serial audio interface IN 2

[5:4] SRC2_INSEL

Sample rate converter IN channels 2 and 3:

00: serial audio interface IN 1

01: ADC

1x: serial audio interface IN 2

[3] MUTE_SRCU0:

1: The device will be put in mute if the SRC is not locked at the 96 kHz sample frequency

[2:0] Reserved

P2SDATA

| | | | | | | | |
|----------|---------|-----------|---|---|-----------|---|---|
| 7 | 6 | 5 | 4 | 3 | 2 | 1 | 0 |
| Reserved | P2S_HFS | P2S1_DSEL | | | P2S2_DSEL | | |

Address: 0xB8**Type:** RW**Reset:** 0x00**Description:**

[7] Reserved

[6] P2S_HFS

SAI OUT:

0: 96 kHz

1: half processing frequency (48 kHz)

[5:3] P2S1_DSEL

SAI OUT 1

000: ADC

001: SAI IN 1

010: SAI IN 2

011: SRC channels 0-1

100: SRC channels 2-3

101: processing channels 0 - 1

110: processing channels 2 - 3

[2:0] P2S2_DSEL

SAI OUT 2

000: ADC

001: SAI IN 1

010: SAI IN 2

011: SRC channels 0-1

100: SRC channels 2-3

101: processing channels 0 - 1

110: processing channels 2 - 3

PLLCFG0

| | | | | | | | |
|-----------|-------------|----------|---|---------|---|---|---|
| 7 | 6 | 5 | 4 | 3 | 2 | 1 | 0 |
| PLL_DPROG | PLL_FR_CTRL | PLL_DDIS | | PLL_IDF | | | |

Address: 0xC0**Type:** RW**Reset:** 0x00**Description:**

[7] 0: PLL takes the internal settings
 1: PLL takes the register settings

[6] PLL_FR_CTRL
 0: fractional frequency synthesis disabled
 1: fractional frequency synthesis enabled

[5:4] PLL_DDIS
 PLL dither disable
 x0: triangular PDF dither input enabled
 x1: triangular PDF dither input disabled
 0x: rectangular PDF dither input enabled
 1x: rectangular PDF dither input disabled

[3:0] PLL_IDF
 Set the input division factor of the PLL (see [Section 5.3: Fractional PLL on page 31](#))

PLLCFG1

| | | | | | | | |
|----------------|---|---|---|---|---|---|---|
| 7 | 6 | 5 | 4 | 3 | 2 | 1 | 0 |
| PLL_FRAC[15:8] | | | | | | | |

Address: 0xC1**Type:** RW**Reset:** 0x00**Description:** See also [Section 5.3: Fractional PLL on page 31](#)

[7:0] PLL_FRAC[15:8]
 The MSBs of PLL_FRAC[15:0] which is used to set the PLL multiplication factor

PLLCFG2

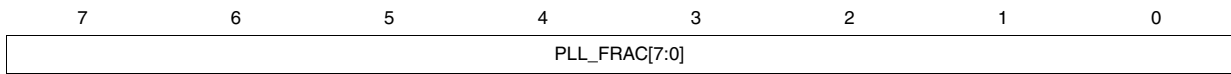

Address: 0xC2
Type: RW
Reset: 0x00
Description: See also [Section 5.3: Fractional PLL on page 31](#)

[7:0] PLL_FRAC[7:0]
 The LSBs of PLL_FRAC[15:0] which is used to set the PLL multiplication factor

PLLCFG3

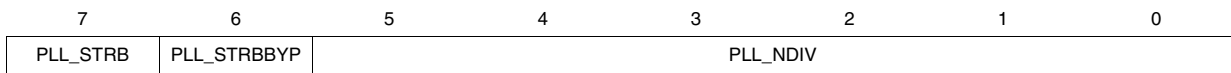

Address: 0xC3
Type: RW
Reset: 0x00
Description: See also [Section 5.3: Fractional PLL on page 31](#)

[7] PLL_STRB
 0: normal behaviour
 1: asynchronous strobe input, a new configuration input is loaded into the fraction controller

[6] PLL_STRBBYP
 0: normal behaviour
 1: bypass the strobe signal

[5:0] PLL_NDIV
 Set the PLL multiplication factor (integral part), loop division factor (LDF)

PLL PFE

| | | | | | | | |
|-------------|-----------|----------|-------------|----------|---|---|---|
| 7 | 6 | 5 | 4 | 3 | 2 | 1 | 0 |
| PLL_BYP_UNL | BICLK2PLL | PLL_PWDN | PLL_NOPDDIV | Reserved | | | |

Address: 0xC4**Type:** RW**Reset:** 0x80**Description:**

- [7] PLL_BYP_UNL
0: PLL clock is not bypassed if it is unlock
1: PLL clock is bypassed if it is unlock, the external clock is used as system clock
- [6] BICLK2PLL
PLL clock in selection
0: normal behaviour
1: BICLK1 is used as PLL clock source
- [5] PLL_PWDN
0: normal behaviour
1: PLL goes into power-down mode
- [4] PLL_NOPDDIV
0: PLL goes to power-down when the divider settings are changed
1: PLL remains active when the divider settings are changed
- [3:0] Reserved

PLLST**PLL status**

| | | | | | | | |
|------------|------------|------------|----------|---|---|---|---|
| 7 | 6 | 5 | 4 | 3 | 2 | 1 | 0 |
| PLL_UNLOCK | PLL_PWD_ST | PLL_BYP_ST | Reserved | | | | |

Address: 0xC5**Type:** RO**Reset:** 0x00**Description:**

- [7] PLL_UNLOCK
0: normal behaviour
1: PLL is not locked
- [6] PLL_PWD_ST
0: normal behaviour
1: PLL is in power-down mode
- [5] PLL_BYP_ST
0: PLL is selected
1: PLL is bypassed

[4:0] Reserved

ADCCFG0

| | | | | | | | |
|---------|---|---|-----------|----------|------------|------------|----------|
| 7 | 6 | 5 | 4 | 3 | 2 | 1 | 0 |
| ADC_PGA | | | ADC_INSEL | ADC_STBY | ADC_BYPCAL | CLK_ADC_ON | Reserved |

Address: 0xC6

Type: RW

Reset: 0x00

Description:

- [7:5] ADC_PGA
 Programmable gain amplifier:
 000: 0 dB
 001: +6 dB
 010: +12 dB
 011: +18 dB
 100: +24 dB
 101: +30 dB
 110: +36 dB
 111: +42 dB
- [4] ADC_INSEL
 0: line input mode selected
 1: mike input mode selected
- [3] ADC_STBY
 0: ADC normal mode
 1: ADC standby mode for power reduction
- [2] ADC_BYPCAL
 0: DC-removal block enabled
 1: bypass DC-removal block
- [1] CLK_ADC_ON
 0: ADC clock disabled
 1: ADC clock active
- [0] Reserved

CKOCFG

| | | | | | | | |
|------------|------------|---|------------|------------|-------------|-----------|----------|
| 7 | 6 | 5 | 4 | 3 | 2 | 1 | 0 |
| CLKOUT_DIS | CLKOUT_SEL | | CLK_FFX_ON | CLK_SRC_ON | CLK_PROC_ON | EAPWM_DIS | PWM00ACT |

Address: 0xC7**Type:** RW**Reset:** 0x1C**Description:**

- [7] CLKOUT_DIS
0: CLKOUT is enabled
1: CLKOUT is disabled
- [6:5] CLKOUT_SEL
00: system clock / 4
01: system clock / 2
10: system clock / 4
11: system clock / 8
- [4] CLK_FFX_ON
0: FFX clock disabled
1: FFX clock active
- [3] CLK_SRC_ON
0: sample rate converter clock disabled
1: sample rate converter clock active
- [2] CLK_PROC_ON
0: process block clock disabled
1: process block clock active
- [1] EAPWM_DIS
0: EA PWM output is enable
1: EA PWM output is disabled
- [0] PWM00ACT
0: output PWM00 is at logical 0
1: Output PWM00 is active

MISC

| | | | | | | | |
|---------|------------|---|---|------------|---|----------|-------------|
| 7 | 6 | 5 | 4 | 3 | 2 | 1 | 0 |
| OSC_DIS | S2P_FS_RNG | | | ADC_FS_RNG | | Reserved | CLK_CORE_ON |

Address: 0xC8**Type:** RW**Reset:** 0x20**Description:**

[7] OSC_DIS

0: normal behaviour

1: XT oscillator is disabled

[6:4] S2P_FS_RNG

Serial audio interface sampling frequency, f_S , range:

000: 8 - 12 kHz (very low)

001: 16 - 24 kHz (low)

010: 32 - 48 kHz (normal)

011: 64 - 96 kHz (high)

100: 128 - 192 kHz (very high)

[3:2] ADC_FS_RNG

ADC sampling frequency, f_S , range:

00: 32 - 48 kHz (normal)

01: 16 - 24 kHz (low)

1x: 8 - 12 kHz (very low)

[1] Reserved

[0] CLK_CORE_ON

0: core clock disabled

1: core clock active

PLL_B

| | | | | | | | |
|---------|----------|------------|----------|-------------|----------|-------------|----------|
| 7 | 6 | 5 | 4 | 3 | 2 | 1 | 0 |
| PLL_BYP | Reserved | ADC_CLKSEL | Reserved | P2S1_CLKSEL | Reserved | P2S2_CLKSEL | Reserved |

Address: 0xC9

Type: RW

Reset: 0x80

Description: See also [Figure 11: Clock management scheme on page 29](#)

- [7] PLL_BYP
0: PLL not bypassed
1: PLL bypassed
- [6] Reserved
- [5] ADC_CLKSEL
0: clk_adc / 4
1: pll_clk_in
- [4] Reserved
- [3] P2S1_CLKSEL
0: processing clock
1: pll_clk_in
- [2] Reserved
- [1] P2S2_CLKSEL
0: processing clock
1: pll_clk_in
- [0] Reserved

HPDET1

| 7 | 6 | 5 | 4 | 3 | 2 | 1 | 0 |
|---------|---------|--------------|---|-----------|-----------|---|---|
| HPD_SEL | HPD_POL | HPD_ACT_MODE | | HPD_HPMOD | HPD_TIM_F | | |

Address: 0xCA**Type:** RW**Reset:** 0x40**Description:**

[7] HPD_SEL
Select the headphone detection threshold
0: HP1
1: HP2

[6] HPD_POL
Polarity of the detection signal

[5:4] HPD_ACT_MODE
Action to be done in case of detection:
00: inactive
01: mute EA and un-mute CB
10: 3-state EA and un-3-state CB
11: power-down EA and power-up CB

[3] HPD_HPMOD
0: normal behaviour
1: FFX is in headphone modulation mode

[2:0] HPD_TIM_F
000: 1.33 ms
001: 2.66 ms
010: 5.33 ms
011: 10.66 ms
100: 21.33 ms
101: 42.66 ms
110: 85.33 ms
111: 170.67 ms

HPDET2

| | | | | | | | |
|-------|-------|--------|----------|---|---|----------|----------|
| 7 | 6 | 5 | 4 | 3 | 2 | 1 | 0 |
| E_HP2 | E_HP1 | TUD_EN | Reserved | | | E_HPDET1 | E_HPDET2 |

Address: 0xCB

Type: RW

Reset: 0xC0

Description:

- [7] E_HP2
0: headphone detection 2 is disabled
1: headphone detection 2 is enabled
- [6] E_HP1
0: headphone detection 1 is disabled
1: headphone detection 1 is enabled
- [5] TUD_EN
1: disable the pull-up resistor of the headphones detector
- [4:2] Reserved
- [1] E_HPDET1
Headphone 1 detector line (not filtered)
- [0] E_HPDET2
Headphone 2 detector line (not filtered)

HPDST

Headphone detection status

| | | | | | | | |
|--------------|----------|---|---|---|---|---|---|
| 7 | 6 | 5 | 4 | 3 | 2 | 1 | 0 |
| HPD_DET_FILT | Reserved | | | | | | |

Address: 0xCC

Type: RO

Reset: 0x00

Description:

- [7] HPD_DET_FILT
0: no headphones
1: headphones detected
- [6:0] Reserved

STBY_MODES

| | | | | | | | |
|-------------|----------|---|---|---|---|----------|--------------|
| 7 | 6 | 5 | 4 | 3 | 2 | 1 | 0 |
| PAD_PULLDIS | Reserved | | | | | CMP_EN_N | DC_STBY_EN_N |

Address: 0xCD

Type: RW

Reset: 0x00

Description:

[7] PAD_PULLDIS
 0: Enable the pull (up/down) of the pads
 1: Disable the pull (up/down) of the pads

[6:2] Reserved

[1] CMP_EN_N
 0: compensation cell is active
 1: compensation cell goes into power-down mode when pin STBY is asserted

[0] DC_STBY_EN_N
 0: DC regulators are active
 1: DC regulators go into power-down mode when pin STBY is asserted

ADCCFG1

ADC analog input selection

| | | | | | | | |
|-------------|---|----------|---|---|---|---|---|
| 7 | 6 | 5 | 4 | 3 | 2 | 1 | 0 |
| ADC_ANA_SEL | | Reserved | | | | | |

Address: 0xCE

Type: RW

Reset: 0x00

Description:

[7:6] ADC_ANA_SEL
 00: INL1, INR1
 01: INL2, INR2
 1x: reserved

[5:0] Reserved

PFEFAULT

| 7 | 6 | 5 | 4 | 3 | 2 | 1 | 0 |
|----------|---|---|------|------|------|-------------|-------------|
| Reserved | | | PFE1 | PFE2 | PFE3 | RESET_EA_FT | RESET_CB_FT |

Address: 0xCF**Type:** RW**Reset:** 0x00**Description:**

[7:5] Reserved

[4] PFE1

0: analog pop free disabled on bridge output 1
1: analog pop free enabled bridge output 1

[3] PFE2

0: analog pop free disabled on bridge output 2
1: analog pop free enabled bridge output 2

[2] PFE3

0: analog pop free disabled on bridge output 3
1: analog pop free enabled bridge output 3

[1] RESET_EA_FT

0: normal operation
1: reset register bit [POWST\[1\]](#)

[0] RESET_CB_FT

0: normal operation
1: reset register bits [POWST1\[5:3\]](#)

BISTRUN0**BIST control**

| 7 | 6 | 5 | 4 | 3 | 2 | 1 | 0 |
|----------|----------|----------|----------|---------|---------|-------------|----------|
| SF1_BRUN | SF2_BRUN | SS1_BRUN | SS2_BRUN | CF_BRUN | PR_BRUN | CF_ROM_BRUN | Reserved |

Address: 0xD0**Type:** RW**Reset:** 0x00**Description:**

- [7] SF1_BRUN
SRC1 RAM
0: normal functional mode
1: start the BIST
- [6] SF2_BRUN
SRC2 RAM
0: normal functional mode
1: start the BIST
- [5] SS1_BRUN
SRC1 RAM
0: normal functional mode
1: start the BIST
- [4] SS2_BRUN
SRC2 RAM
0: normal functional mode
1: start the BIST
- [3] CF_BRUN
PROC RAM (coefficients)
0: normal functional mode
1: start the BIST
- [2] PR_BRUN
PROC RAM (program)
0: normal functional mode
1: start the BIST
- [1] CF_ROM_BRUN
PROC RAM (coefficients)
0: normal functional mode
1: start the BIST
- [0] Reserved

BISTRUN1

| | | | | | | | |
|---------|---------|----------|---|---|---|---|---|
| 7 | 6 | 5 | 4 | 3 | 2 | 1 | 0 |
| OS_BRUN | DB_BRUN | Reserved | | | | | |

Address: 0xD1

Type: RW

Reset: 0x00

Description:

- [7] OS_BRUN
FFX RAM
0: normal functional mode
1: start the BIST
- [6] DB_BRUN
FFX RAM
0: normal functional mode
1: start the BIST
- [5:0] Reserved

BISTST0

BIST status register 0

| | | | | | | | |
|----------|----------|-----------|----------|----------|-----------|----------|----------|
| 7 | 6 | 5 | 4 | 3 | 2 | 1 | 0 |
| SF1_BEND | SF1_BBAD | SF1_BFAIL | SF2_BEND | SF2_BBAD | SF2_BFAIL | SS1_BEND | SS1_BBAD |

Address: 0xD2

Type: RO

Reset: 0x00

Description:

- [7] SF1_BEND:
For SRC1 RAM BIST
0: normal functional mode
1: BIST is finished
- [6] SF1_BBAD
For SRC1 RAM BIST
0: no faults detected
1: at least one fault detected
- [5] SF1_BFAIL
For SRC1 RAM BIST
0: no faults detected in the current location
1: at least one fault detected in the current location

- [4] SF2_BEND
For SRC2 RAM BIST
0: normal functional mode
1: BIST is finished
- [3] SF2_BBAD
For SRC2 RAM BIST
0: no faults detected
1: at least one fault detected
- [2] SF2_BFAIL
For SRC2 RAM BIST
0: no faults detected in the current location
1: at least one fault detected in the current location
- [1] SS1_BEND
For SRC1 RAM BIST
0: normal functional mode
1: BIST is finished
- [0] SS1_BBAD
For SRC1 RAM BIST
0: no faults detected
1: at least one fault detected

BISTST1**BIST status register 1**

| 7 | 6 | 5 | 4 | 3 | 2 | 1 | 0 |
|-----------|----------|----------|-----------|---------|---------|----------|---------|
| SS1_BFAIL | SS2_BEND | SS2_BBAD | SS2_BFAIL | CF_BEND | CF_BBAD | CF_BFAIL | PR_BEND |

Address: 0xD3**Type:** RO**Reset:** 0x00**Description:**

- [7] SS1_BFAIL
For SRC1 RAM BIST
0: no faults detected in the current location
1: at least one fault detected in the current location
- [6] SS2_BEND:
For SRC2 RAM BIST
0: normal functional mode
1: BIST is finished
- [5] SS2_BBAD
For SRC2 RAM BIST
0: no faults detected
1: at least one fault detected
- [4] SS2_BFAIL
For SRC2 RAM BIST
0: no faults detected in the current location
1: at least one fault detected in the current location
- [3] CF_BEND:
For PROC RAM BIST
0: normal functional mode
1: BIST is finished
- [2] CF_BBAD
For PROC RAM BIST
0: no faults detected
1: at least one fault detected
- [1] CF_BFAIL
For PROC RAM BIST
0: no faults detected in the current location
1: at least one fault detected in the current location
- [0] PR_BEND:
For PROC RAM BIST
0: normal functional mode
1: BIST is finished

BISTST2 **BIST status register 2**

| | | | | | | | |
|---------|----------|---------|---------|----------|---------|---------|----------|
| 7 | 6 | 5 | 4 | 3 | 2 | 1 | 0 |
| PR_BBAD | PR_BFAIL | OS_BEND | OS_BBAD | OS_BFAIL | DB_BEND | DB_BBAD | DB_BFAIL |

Address: 0xD4

Type: RO

Reset: 0x00

Description:

- [7] PR_BBAD
For PROC RAM BIST
0: no faults detected
1: at least one fault detected
- [6] PR_BFAIL
For PROC RAM BIST
0: no faults detected in the current location
1: at least one fault detected in the current location
- [5] OS_BEND:
For FFX RAM BIST
0: normal functional mode
1: BIST is finished
- [4] OS_BBAD
For FFX RAM BIST
0: no faults detected
1: at least one fault detected
- [3] OS_BFAIL
For FFX RAM BIST
0: no faults detected in the current location
1: at least one fault detected in the current location
- [2] DB_BEND:
For FFX RAM BIST
0: normal functional mode
1: BIST is finished
- [1] DB_BBAD
For FFX RAM BIST
0: no faults detected
1: at least one fault detected
- [0] DB_BFAIL
For FFX RAM BIST
0: no faults detected in the current location
1: at least one fault detected in the current location

BISTST3**BIST status register 3**

| | | | | | | | |
|-------------|----------|---|---|---|---|---|---|
| 7 | 6 | 5 | 4 | 3 | 2 | 1 | 0 |
| CF_ROM_BEND | Reserved | | | | | | |

Address: 0xD5

Type: RO

Reset: 0x00

Description:

[7] CF_ROM_BEND
ROM BIST computation is finished

[6:0] Reserved

ROMSIGN0 ROM BIST signature (LSBs)



Address: 0xD6

Type: RO

Reset: 0x00

Description:

[7:0] CF_ROMS[7:0]
 LSBs of ROM BIST signature CF_ROMS[23:0]

ROMSIGN1 ROM BIST signature (middle bits)



Address: 0xD7

Type: RO

Reset: 0x00

Description:

[7:0] CF_ROMS[15:8]
 Middle bits of ROM BIST signature CF_ROMS[23:0]

ROMSIGN2 ROM BIST signature (MSBs)

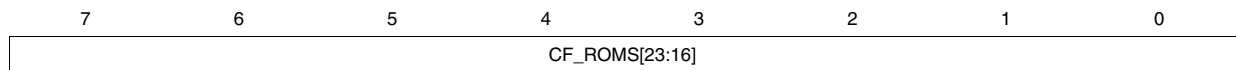

Address: 0xD8

Type: RO

Reset: 0x00

Description:

[7:0] CF_ROMS[23:16]
 MSBs of ROM BIST signature CF_ROMS[23:0]

DEBUG0

| | | | | | | | |
|-----------|---|------------|---|---|---|---|---|
| 7 | 6 | 5 | 4 | 3 | 2 | 1 | 0 |
| DBGCKO_ON | | DBGCKO_VAL | | | | | |

Address: 0xD9**Type:** RW**Reset:** 0x00**Description:**

[7] DBGCKO_ON

0: normal behaviour

1: CLKOUT exports internal clocks as defined by bits DBGCKO_VAL

[6:0] DBGCKO_VAL

0x00: invalid_inp_fbk

0x01: mute_int_fbk

0x02: binss_fbk

0x21: debug_start

0x22: debug_data_end

0x23: debug_data_ok

0x24: debug_lrcclk_old

0x25: debug_biclk

0x40: clk_proc

0x41: clk_src

0x42: clk_ffx

0x50: src_1_lock

0x51: src_2_lock

0x52: src_1_bypass_state[0]

0x53: src_1_bypass_state[1]

0x54: src_2_bypass_state[0]

0x55: src_2_bypass_state[1]

0x56: pwm_sync

0x57: s2p_1_bad_clocks

0x58: s2p_2_bad_clocks

0x59: s2p_1_missing_biclk

all other values: no clock exported

PADST0 **Pad status 0**

| | | | | | | | |
|----------|----------|---------|---------|------------|----------|---|----------|
| 7 | 6 | 5 | 4 | 3 | 2 | 1 | 0 |
| PAD_RSTN | Reserved | PAD_SCL | PAD_SDA | PAD_I2CDIS | Reserved | | PAD_STBY |

Address: 0xF0

Type: RO

Reset: 0xA0

Description:

- [7] PAD_RSTN
- [6] Reserved
- [5] PAD_SCL
- [4] PAD_SDA
- [3] PAD_I2CDIS
- [2:1] Reserved
- [0] PAD_STBY

PADST1

| | | | | | | | |
|----------|------------|------------|------------|------------|------------|----------|---|
| 7 | 6 | 5 | 4 | 3 | 2 | 1 | 0 |
| PAD_MUTE | PAD_BICLKI | PAD_LRCLKI | PAD_SDATAI | PAD_BICLKO | PAD_LRCLKO | Reserved | |

Address: 0xF1

Type: RW

Reset: 0x74

Description:

- [7] PAD_MUTE
- [6] PAD_BICLKI
- [5] PAD_LRCLKI
- [4] PAD_SDATAI
- [3] PAD_BICLKO
- [2] PAD_LRCLKO
- [1:0] Reserved

15 I²C disabled (microless) mode

Figure 55. Microless mode block diagram

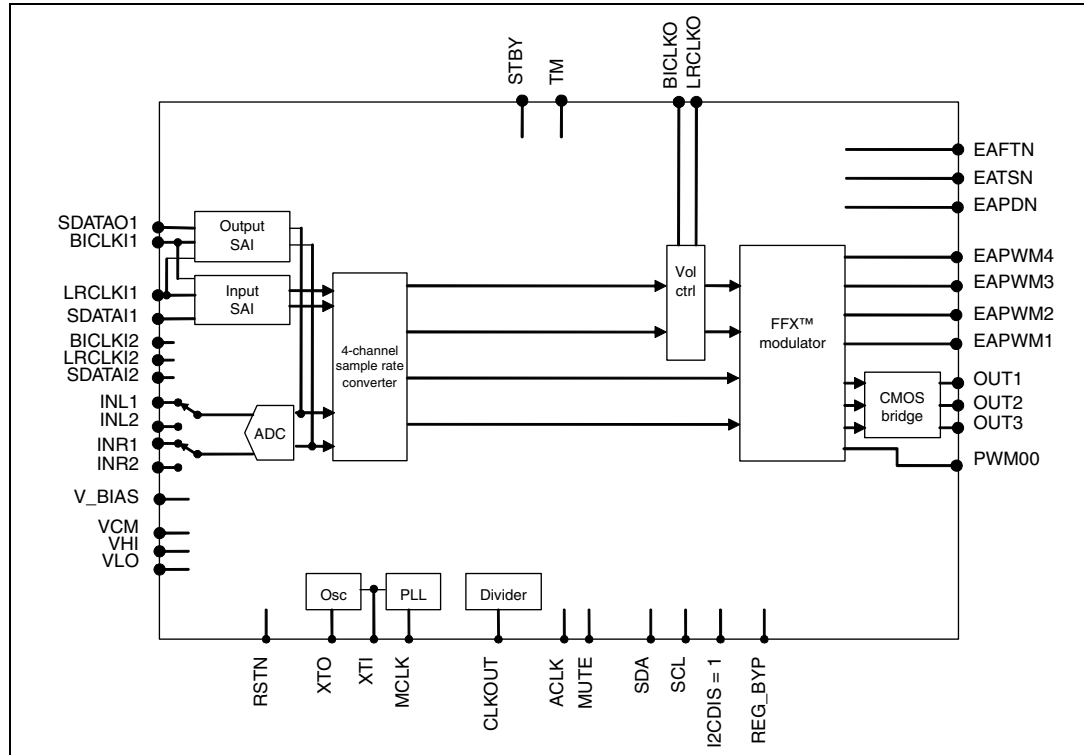

In microless mode (I2CDIS = 1) the I²C interface is inhibited and SDA and SCL are used as static inputs. The device is working in the configuration shown in *Figure 55* with the ADC connected to input line 1 and to SAI out. The processing chain uses the inputs from SAI input 1. The working modes are selected via the logical levels on the inputs SDA, SCL as follows:

- SCL = 0 : CMOS bridge outputs come from digital input serial audio interface;
SCL = 1 : CMOS bridge outputs come from analog ADC input.
- SDA = 0 : external amplifier outputs come from digital input serial audio interface;
SDA = 1 : external amplifier outputs come from analog ADC input.

At power-up the channel volume is set to -60 dB. The volume is controlled by pulsing the inputs LRCLK0 and BICLK0 as follows:

- when pulsing LRCLK0 = 1 and BICLK0 = 1 simultaneously the channel volume is set to 0 dB.
- Any LRCLK0 = 1 pulse causes a channel volume decrease of 0.5 dB.
- Any BICLK0 = 1 pulse causes a channel volume increase of 0.5 dB.

The channel volume change applies only to the external amplifier.

The digital output serial audio interface is always fed with the result of the ADC conversion with no volume control (line-out mode). It is in master mode when SCL = 1 and SDA = 1 otherwise it is in slave mode. It is configured in I²S format.

The LRCLK and BICLK signals are shared between input and output SAI.

The input sampling frequency must be between 32 kHz and 48 kHz and the master clock input (MCLK or XTI) must be $256 * f_S$.

The CMOS bridge FFX output is configured in line-out mode:

- left channel binary on OUT1
- right channel binary on OUT2
- zero signal binary (duty cycle 50%) on OUT3
- pop-free digital ramp active
- volume control not effective (always 0 dB)
- switching frequency 384 kHz.

The external amplifier FFX output is configured in BTL mode:

- left channel BTL (new ternary modulation) on EAPWM1 and EAPWM2
- right channel BTL (new ternary modulation) on EAPWM1 and EAPWM2
- volume control is effective
- switching frequency 384 kHz.

The headphone detection is disabled.

The CLKOUT pad is active at the PLL frequency of $2048 * f_S$.

16 Package mechanical data

The STA321 comes in a 64-pin, 10 mm x 10 mm, LQFP, exposed pad down (EPD) package. The reference number is JEDEC MS-026-BCD-HD.

In order to meet environmental requirements, ST offers these devices in different grades of ECOPACK® packages, depending on their level of environmental compliance. ECOPACK® specifications, grade definitions and product status are available at: www.st.com. ECOPACK® is an ST trademark.

Figure 56. LQFP-64L EPD outline drawing

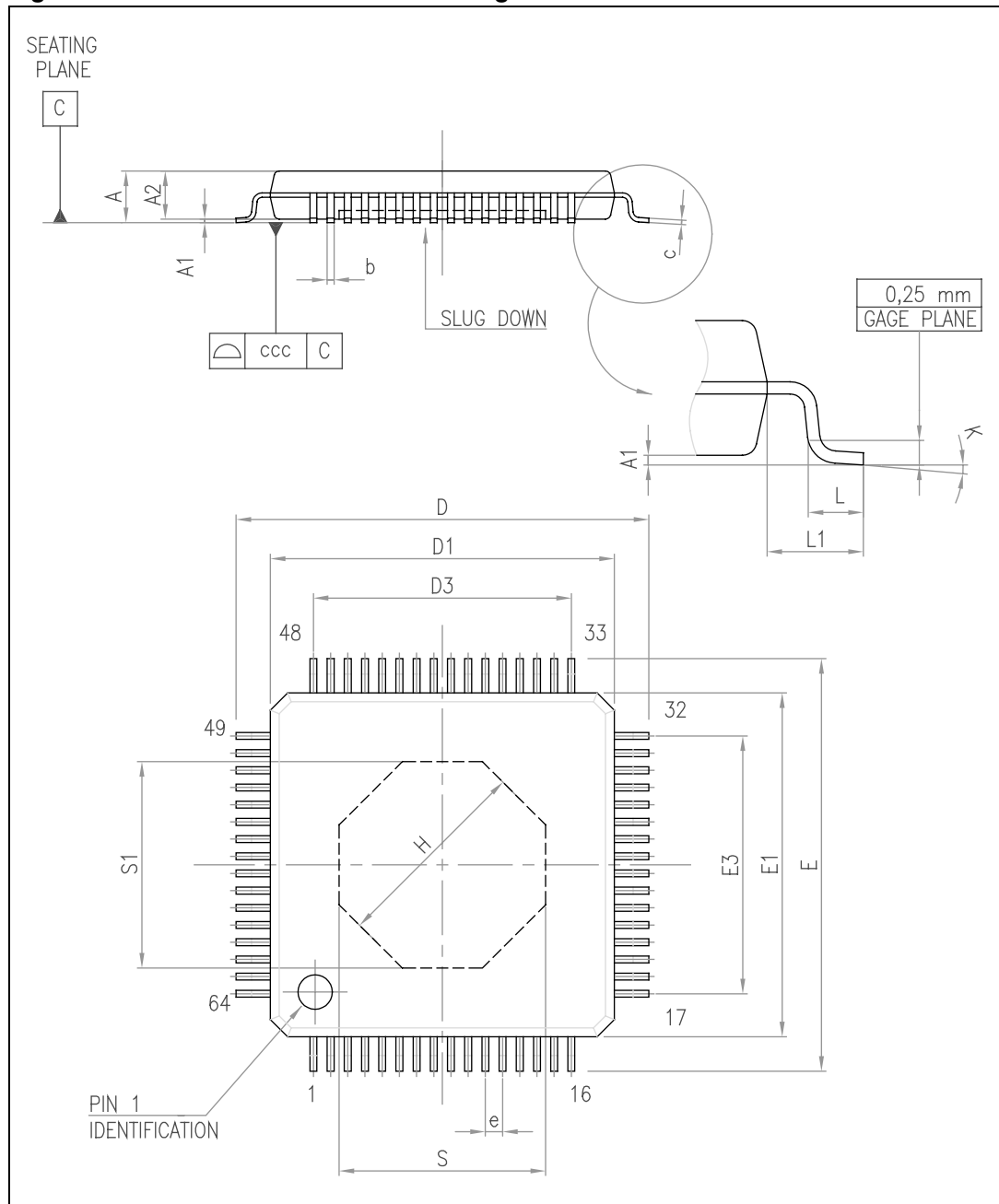

Table 36. LQFP-64L EPD dimensions

| Symbol | Dimensions in mm | | | Dimensions in inches | | | Notes |
|--------|------------------|-------|-------|----------------------|-------|-------|-------------|
| | Min | Typ | Max | Min | Typ | Max | |
| A | - | - | 1.60 | - | - | 0.063 | - |
| A1 | 0.05 | - | 0.15 | 0.002 | - | 0.006 | - |
| A2 | 1.35 | 1.40 | 1.45 | 0.053 | 0.055 | 0.057 | - |
| b | 0.17 | 0.22 | 0.27 | 0.007 | 0.009 | 0.011 | - |
| c | 0.09 | - | 0.20 | 0.004 | - | 0.008 | - |
| D | 11.80 | 12.00 | 12.20 | 0.465 | 0.472 | 0.480 | - |
| D1 | 9.80 | 10.00 | 10.20 | 0.386 | 0.394 | 0.402 | - |
| D3 | - | 7.50 | - | - | 0.295 | - | - |
| E | 11.80 | 12.00 | 12.20 | 0.465 | 0.472 | 0.480 | - |
| E1 | 9.80 | 10.00 | 10.20 | 0.386 | 0.394 | 0.402 | - |
| E3 | - | 7.50 | - | - | 0.295 | - | - |
| e | - | 0.50 | - | - | 0.020 | - | - |
| H | - | 5.89 | - | - | 0.232 | - | - |
| L | 0.45 | 0.60 | 0.75 | 0.018 | 0.024 | 0.030 | - |
| L1 | - | 1.00 | - | - | 0.039 | - | - |
| S | 6.00 | - | - | 0.236 | - | - | Exposed pad |
| S1 | 6.00 | - | - | 0.236 | - | - | Exposed pad |
| ccc | - | - | 0.08 | - | - | 0.003 | - |
| k | 0 | 3.5 | 7.0 | 0 | 3.5 | 7.0 | Degrees |

17 Glossary

Total harmonic distortion + noise (THDN)

The ratio of the RMS value of all the spectral components in the specified band (20 Hz - 20 kHz) to the RMS values of the signal fundamental component. THDN is measured at 0 dBfs input at a frequency of 1 kHz.

Signal to noise plus distortion ratio (SNDR)

Ratio between power of signal fundamental component and “noise+distortion”. It is measured at different input levels: 0 dBfs, -3 dBfs, -6 dBfs, -10 dBfs, -20 dBfs, -40 dBfs, -60 dBfs. When the signal amplitude is less than 0 dBfs, that much dB is added to obtain the final SNR. For example, if SNDR is 87 dB with -6dBfs signal, then $SNR = 87 + 6 = 93$ dB.

Dynamic range (DR)

Dynamic range is measured using SNDR at -60 dBfs, 1 kHz signal and adding 60 dB. For example, if SNDR with -60 dBfs is 38 dB then the dynamic range is $38 + 60 = 98$ dB.

Crosstalk

Crosstalk is the measure of the inter-channel isolation between the left and right channels of a stereo system. It is measured at each output with zero input to the channel under test and a full-scale input applied to the other channel.

Deviation from linear phase

Measurement bandwidth 20 Hz to 20 kHz, $f_s = 48$ kHz. The measurement takes into account the combined digital and analog filter characteristics.

Pass band, pass-band ripple, stop band, stop-band attenuation

These parameters take into account both analog and digital filter characteristics. Stop-band attenuation should be measured between $0.55 * f_s$ and $3.45 * f_s$.

18 Trademarks and other acknowledgements

SoundTerminal, FFX and pfStart are trademarks of STMicroelectronics.
ECOPACK is a registered trademark of STMicroelectronics.

19 Revision history

Table 37. Document revision history

| Date | Revision | Changes |
|-------------|----------|---|
| 27-Mar-2009 | 1 | Initial release. |
| 11-May-2009 | 2 | Updated Table 1: Device summary on page 1 Added ambient temperature to Table 5: Recommended operating conditions on page 13 Updated Table 6: Electrical specifications on page 14 Updated resistor to 32 Ω in Figure 3: Test circuit on page 17 Updated and moved Headphone detector threshold limits table from Chapter 12 on page 72 and merged into Table 6: Electrical specifications on page 14 Updated HPDET2 bitfield in Table 34: Register summary on page 77 Updated description of register HPDET2 on page 138 |
| 30-Oct-2009 | 3 | Updates to feature list on page 1 Updated Chapter 1: Overview on page 9 Updated Chapter 16: Package mechanical data on page 152 |

Please Read Carefully:

Information in this document is provided solely in connection with ST products. STMicroelectronics NV and its subsidiaries ("ST") reserve the right to make changes, corrections, modifications or improvements, to this document, and the products and services described herein at any time, without notice.

All ST products are sold pursuant to ST's terms and conditions of sale.

Purchasers are solely responsible for the choice, selection and use of the ST products and services described herein, and ST assumes no liability whatsoever relating to the choice, selection or use of the ST products and services described herein.

No license, express or implied, by estoppel or otherwise, to any intellectual property rights is granted under this document. If any part of this document refers to any third party products or services it shall not be deemed a license grant by ST for the use of such third party products or services, or any intellectual property contained therein or considered as a warranty covering the use in any manner whatsoever of such third party products or services or any intellectual property contained therein.

UNLESS OTHERWISE SET FORTH IN ST'S TERMS AND CONDITIONS OF SALE ST DISCLAIMS ANY EXPRESS OR IMPLIED WARRANTY WITH RESPECT TO THE USE AND/OR SALE OF ST PRODUCTS INCLUDING WITHOUT LIMITATION IMPLIED WARRANTIES OF MERCHANTABILITY, FITNESS FOR A PARTICULAR PURPOSE (AND THEIR EQUIVALENTS UNDER THE LAWS OF ANY JURISDICTION), OR INFRINGEMENT OF ANY PATENT, COPYRIGHT OR OTHER INTELLECTUAL PROPERTY RIGHT.

UNLESS EXPRESSLY APPROVED IN WRITING BY AN AUTHORIZED ST REPRESENTATIVE, ST PRODUCTS ARE NOT RECOMMENDED, AUTHORIZED OR WARRANTED FOR USE IN MILITARY, AIR CRAFT, SPACE, LIFE SAVING, OR LIFE SUSTAINING APPLICATIONS, NOR IN PRODUCTS OR SYSTEMS WHERE FAILURE OR MALFUNCTION MAY RESULT IN PERSONAL INJURY, DEATH, OR SEVERE PROPERTY OR ENVIRONMENTAL DAMAGE. ST PRODUCTS WHICH ARE NOT SPECIFIED AS "AUTOMOTIVE GRADE" MAY ONLY BE USED IN AUTOMOTIVE APPLICATIONS AT USER'S OWN RISK.

Resale of ST products with provisions different from the statements and/or technical features set forth in this document shall immediately void any warranty granted by ST for the ST product or service described herein and shall not create or extend in any manner whatsoever, any liability of ST.

ST and the ST logo are trademarks or registered trademarks of ST in various countries.

Information in this document supersedes and replaces all information previously supplied.

The ST logo is a registered trademark of STMicroelectronics. All other names are the property of their respective owners.

© 2009 STMicroelectronics - All rights reserved

STMicroelectronics group of companies

Australia - Belgium - Brazil - Canada - China - Czech Republic - Finland - France - Germany - Hong Kong - India - Israel - Italy - Japan - Malaysia - Malta - Morocco - Philippines - Singapore - Spain - Sweden - Switzerland - United Kingdom - United States of America

www.st.com

