

VS-550 Dual Frequency VCSO

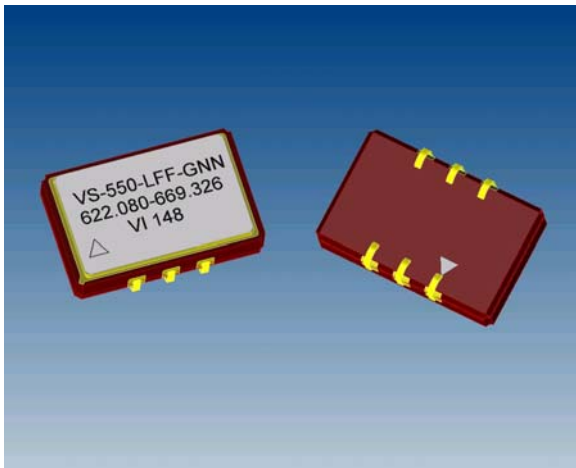

Features

- 9 x 14 x 3.5 mm Package
- Output Frequencies from 500 MHz to 850 MHz
- 3.3 V Operation
- Low Jitter < 0.25 ps-rms across 50 kHz to 80 MHz
- LV-PECL Configuration with Fast Transition Times
- Complementary Outputs
- Frequency Select Feature



Product is free of lead and compliant to EC RoHS Directive

Applications

PLL circuits for Clock Smoothing and Frequency Translation

| <u>Description</u> | <u>Standard</u> |
|---------------------|--------------------|
| • 10G Fibre Channel | INCITS 364-2003 |
| • 10GbE LAN / WAN | IEEE 802.3ae |
| • OC-192 | ITU-T G.709 |
| • SONET / SDH | GR-253-CORE Issue3 |

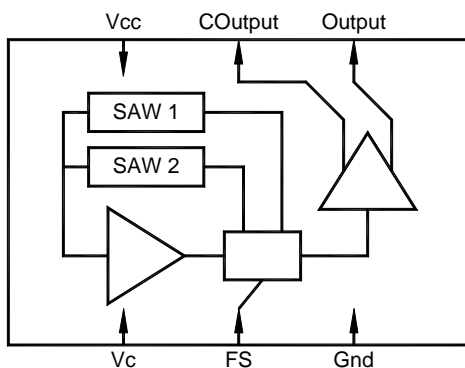

Description

The VS-550 is a SAW based voltage controlled oscillator that operates at the fundamental frequencies of the internal SAW filters. These SAW filters are high-Q quartz devices that enable the circuit to achieve low phase jitter performance over a wide operating temperature range. The dual oscillator is housed in a hermetically sealed J-lead surface mount package offered on tape and reel. It has a frequency select function that enables either "Frequency 1" or "Frequency 2."

VS-550 Voltage Controlled SAW Oscillator

Electrical Performance

| Parameter | Symbol | Minimum | Typical | Maximum | Units | Notes |
|------------------------------|------------|------------------|--------------|--------------|--------|---------|
| Frequency | | | | | | |
| Nominal Frequency | f_N | | 500 - 850 | | MHz | 1,2,3 |
| Absolute Pull Range | APR | ±50 | | | ppm | 1,2,3,8 |
| Linearity | L_{in} | | ±5 | | % | 2,4,8 |
| Gain Transfer (See Pg 5) | K_V | | +385 | | ppm/V | 2,8 |
| Temperature Stability | f_{STAB} | | ±100 | | ppm | 1,6 |
| Transition Time | | | 4 | | µsec | 6 |
| Supply | | | | | | |
| Voltage | V_{CC} | 2.97 | 3.3 | 3.63 | V | 2,3 |
| Current (No Load) | I_{CC} | | 55 | 70 | mA | 3 |
| Outputs | | | | | | |
| Mid Level | | $V_{CC}-1.4$ | $V_{CC}-1.3$ | $V_{CC}-1.2$ | V | 2,3 |
| Swing | | 550 | 650 | 950 | mV-pp | 2,3 |
| Current | I_{OUT} | | | 20 | mA | 6 |
| Rise Time | t_R | | 250 | 400 | ps | 5,6 |
| Fall Time | t_F | | 250 | 400 | ps | 5,6 |
| Symmetry | SYM | 45 | 50 | 55 | % | 2,3 |
| Spurious Suppression | | 50 | 60 | | dBc | 6 |
| Jitter (See Pg 5) | ϕ_J | | 0.135 | 0.250 | ps-rms | 6,7 |
| Control Voltage | | | | | | |
| Input Impedance | Z_c | | 100 | | kΩ | 6 |
| Modulation Bandwidth | BW | | 500 | | kHz | 6 |
| Operating Temperature | | | | | | |
| | T_{OP} | -40 | | 85 | °C | 1,3 |
| Package Size | | | | | | |
| | | 9.0 x 14.0 x 3.5 | | | mm | |

1. See Standard Frequencies and Ordering Information (Pg 7).
2. Parameters are tested with production test circuit below (Fig 1).
3. Parameters are tested at ambient temperature with test limits guardbanded for specified operating temperature.
4. Measured as the maximum deviation from the best straight-line fit, per MIL-0-55310.
5. Measured from 20% to 80% of a full output swing (Fig 2).
6. Not tested in production, guaranteed by design, verified at qualification.
7. Integrated across 50 kHz to 80 MHz, per GR-253-CORE Issue3.
8. Tested with $V_c = 0.3V$ to $3.0V$.

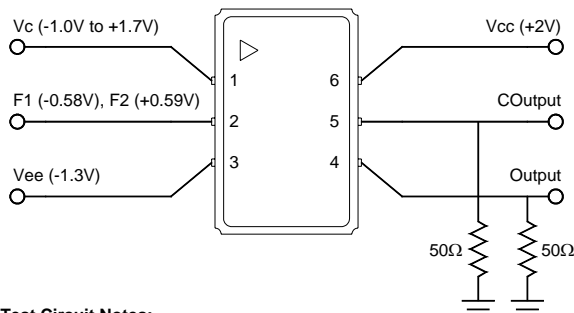

Test Circuit Notes:

- 1) To Permit 50Ω Measurement of Outputs, all DC Inputs are Biased Down 1.3V.
- 2) All Voltage Sources Contain Bypass Capacitors to Minimize Supply Noise.
- 3) 50Ω Terminations are Within Test Equipment.

Figure 1. Test Circuit

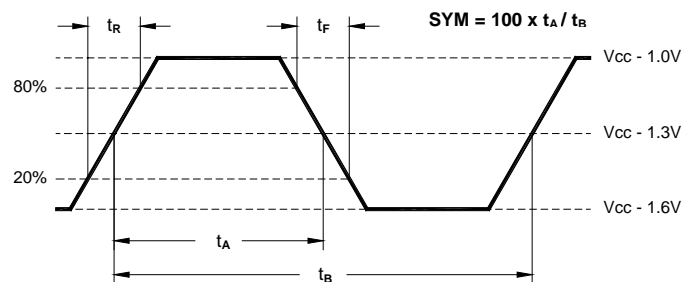
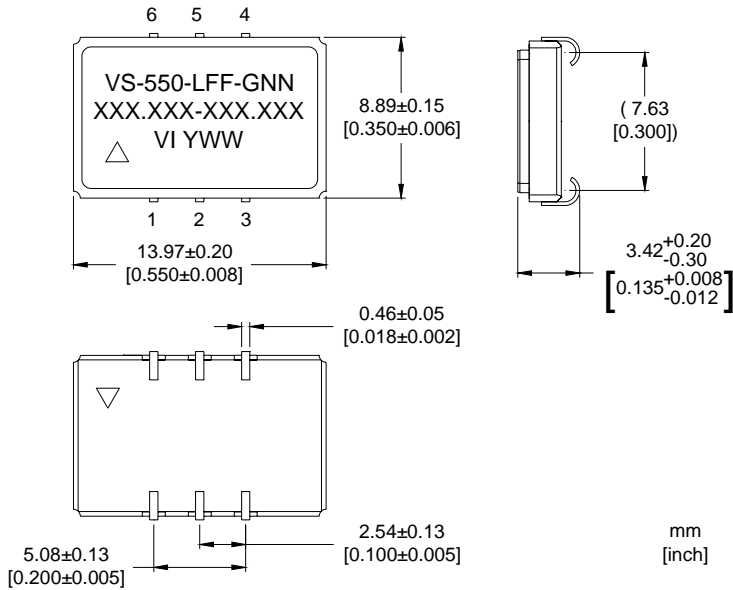

Figure 2. 10K LV-PECL Waveform

VS-550 Voltage Controlled SAW Oscillator

Outline Diagram



Pad Layout

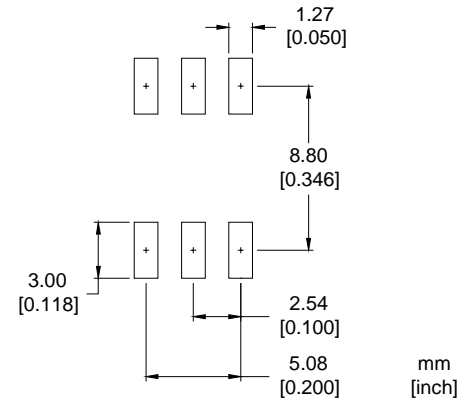

Pin Out

| Pin | Symbol | Function |
|-----|-----------------|--------------------------------------|
| 1 | V _c | VCSO Control Voltage |
| 2 | FS | Frequency Select (See Control Logic) |
| 3 | GND | Case and Electrical Ground |
| 4 | Output | VCSO Output |
| 5 | COutput | VCSO Complementary Output |
| 6 | V _{cc} | Power Supply Voltage (3.3 V ±10%) |

Control Logic (LV-CMOS)

| FS | Operation |
|----|-----------|
| 0 | F1 |
| 1 | F2 |

Tape and Reel (EIA-481-2-A)

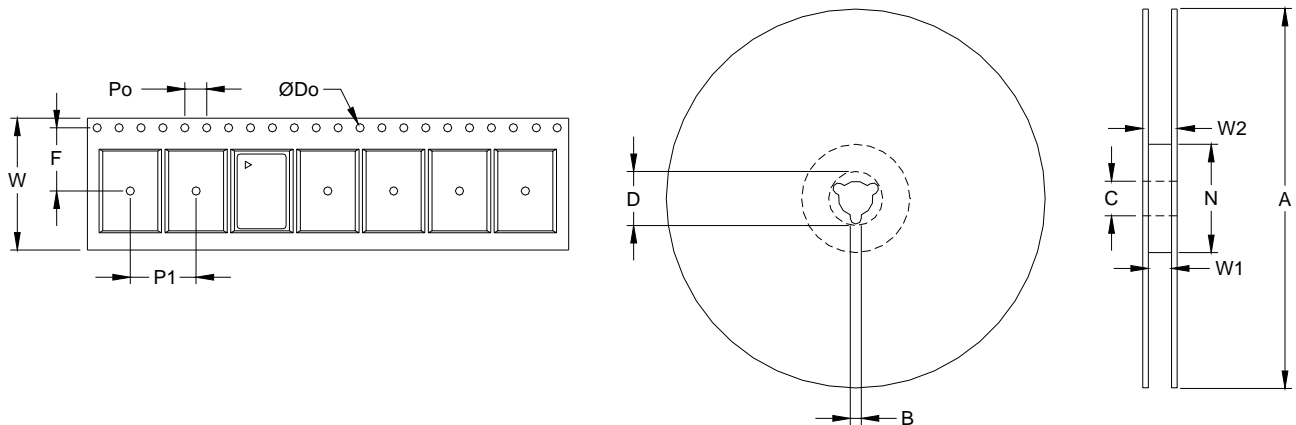

Tape Dimensions (mm) | Reel Dimensions (mm)

| Dimension | W | F | Do | Po | P1 | A | B | C | D | N | W1 | W2 | # Per Reel |
|-----------|-----|------|-----|-----|-----|-----|-----|-----|------|-----|------|------|------------|
| Tolerance | Typ | Typ | Typ | Typ | Typ | Typ | Min | Typ | Min | Min | Typ | Max | |
| VS-550 | 24 | 11.5 | 1.5 | 4 | 12 | 330 | 1.5 | 13 | 20.2 | 100 | 24.4 | 30.4 | 200 |

VS-550 Voltage Controlled SAW Oscillator

Absolute Maximum Ratings

| Parameter | Symbol | Ratings | Unit |
|-------------------------------|------------------|---------------|----------|
| Power Supply | V_{CC} | 0 to 6 | V |
| Input Current | I_{IN} | 100 | mA |
| Output Current | I_{OUT} | 25 | mA |
| Voltage Control Range | V_C | 0 to V_{CC} | V |
| Storage Temperature | T_{STR} | -55 to 125 | °C |
| Solder Temperature / Duration | T_{PEAK} / t_p | 260 / 40 | °C / sec |

Stresses in excess of the absolute maximum ratings can permanently damage the device. Also, exposure to these absolute maximum ratings for extended periods may adversely affect device reliability. Functional operation is not implied at these or any other conditions in excess of those represented in the operational sections of this datasheet. Permanent damage is also possible if any device input (V_C or FS) draws greater than 100mA.

Suggested Output Load Configurations

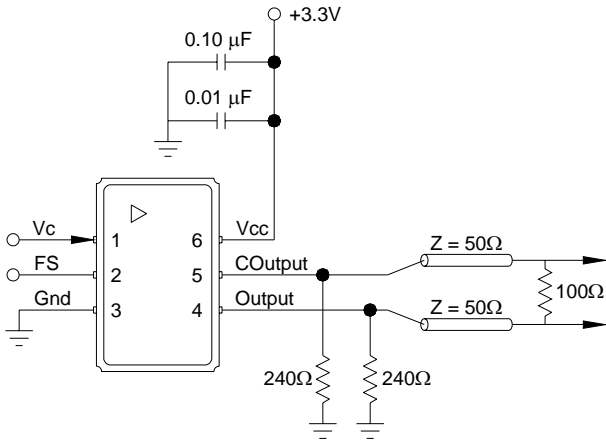

LV-PECL to LV-PECL: For short transmission lengths, the power consumption could be reduced by removing the 100Ω resistor and doubling the value of the pull down resistors.

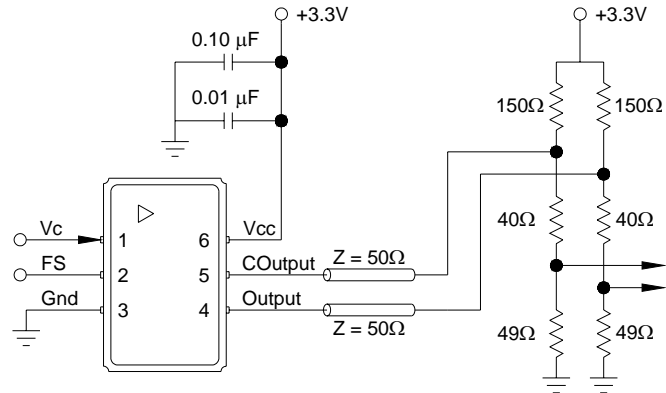

LV-PECL to LVDS: Restricted for short transmission lengths. Configuration may require modification depending on LVDS receiver.

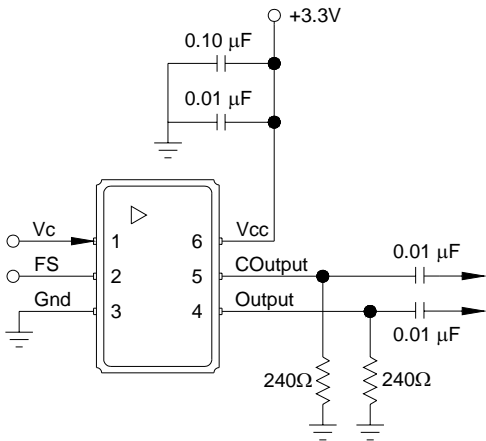

Functional Test: Allows standard power supply configuration. Since AC coupled, the LV-PECL levels cannot be measured.

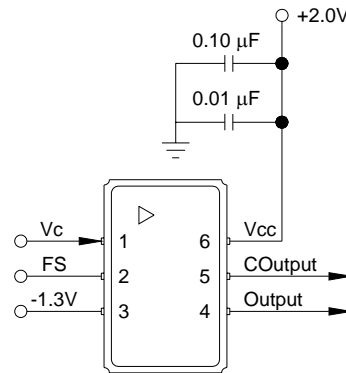

Production Test: Allows direct DC coupling into 50Ω measurement equipment. Must bias the power supplies as shown. Similar to Figure 1.

VS-550 Voltage Controlled SAW Oscillator

Typical Characteristics

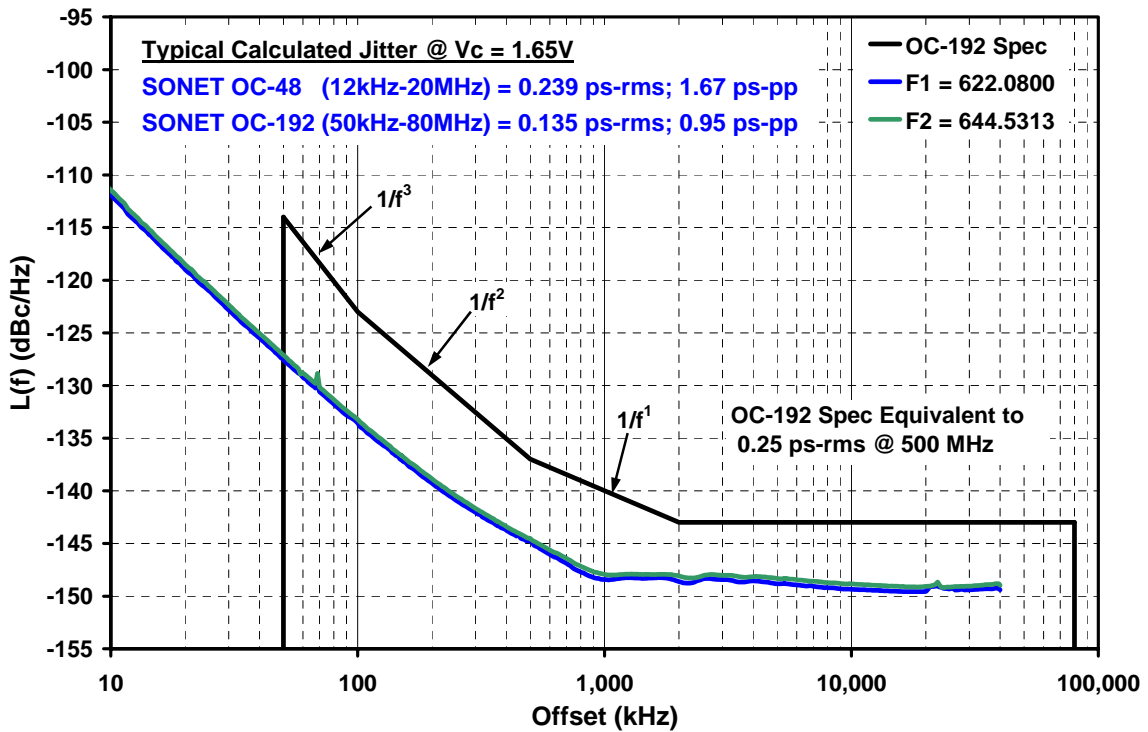
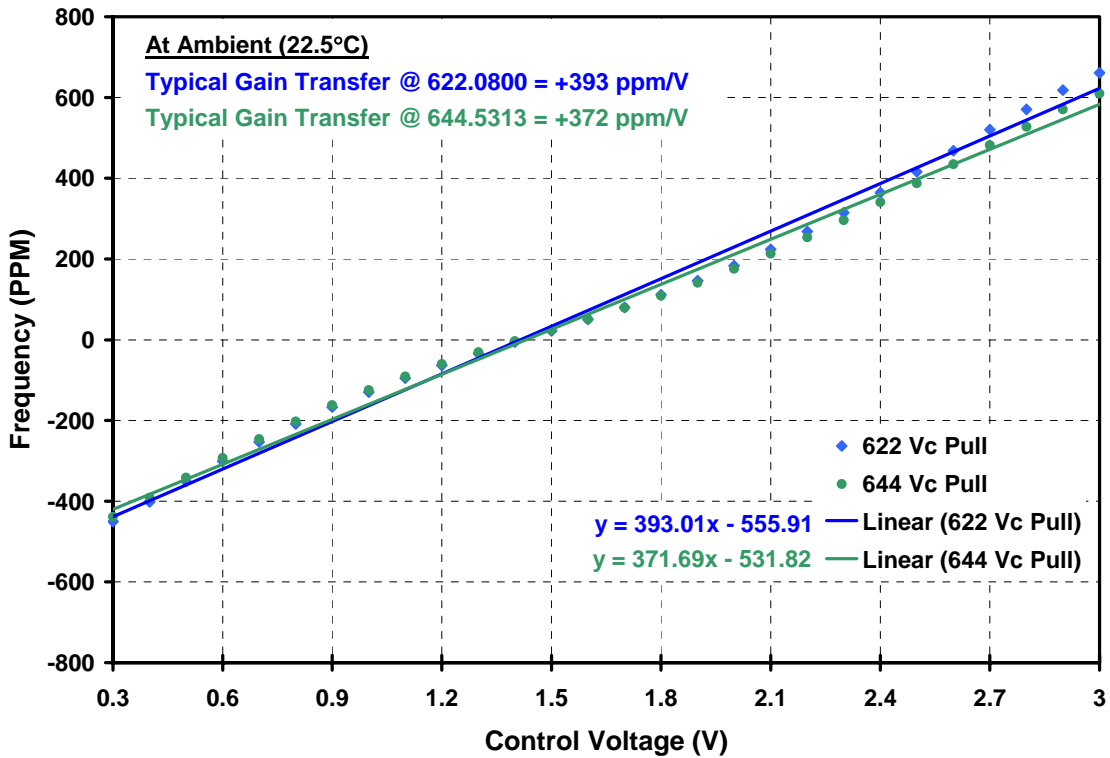

VS-550 Voltage Controlled SAW Oscillator

Reliability

VI qualification includes aging at various extreme temperatures, shock and vibration, temperature cycling, and IR reflow simulation. The VS-550 family is capable of meeting the following qualification tests:

Environmental Compliance

| Parameter | Conditions |
|------------------------|--------------------------|
| Mechanical Shock | MIL-STD-883, Method 2002 |
| Mechanical Vibration | MIL-STD-883, Method 2007 |
| Solderability | MIL-STD-883, Method 2003 |
| Gross and Fine Leak | MIL-STD-883, Method 1014 |
| Resistance to Solvents | MIL-STD-883, Method 2016 |

Handling Precautions

Although ESD protection circuitry has been designed into the VS-550 proper precautions should be taken when handling and mounting. VI employs a human body model (HBM) and a charged-device model (CDM) for ESD susceptibility testing and design protection evaluation.

ESD Ratings

| Model | Minimum | Conditions |
|----------------------|---------|--------------------------|
| Human Body Model | 1500 V | MIL-STD 883, Method 3015 |
| Charged Device Model | 1000 V | JEDEC, JESD22-C101 |

Reflow Profile (IPC/JEDEC J-STD-020C)

| Parameter | Symbol | Value |
|--------------------------|-------------|-------------------------|
| PreHeat Time | t_s | 60 sec Min, 180 sec Max |
| Ramp Up | R_{UP} | 3 °C/sec Max |
| Time Above 217 °C | t_L | 60 sec Min, 150 sec Max |
| Time To Peak Temperature | t_{AMB-P} | 480 sec Max |
| Time At 260 °C | t_P | 20 sec Min, 40 sec Max |
| Ramp Down | R_{DN} | 6 °C/sec Max |

The device has been qualified to meet the JEDEC standard for Pb-Free assembly. The temperatures and time intervals listed are based on the Pb-Free small body requirements. The temperatures refer to the topside of the package, measured on the package body surface. The VS-550 device is hermetically sealed so an aqueous wash is not an issue.

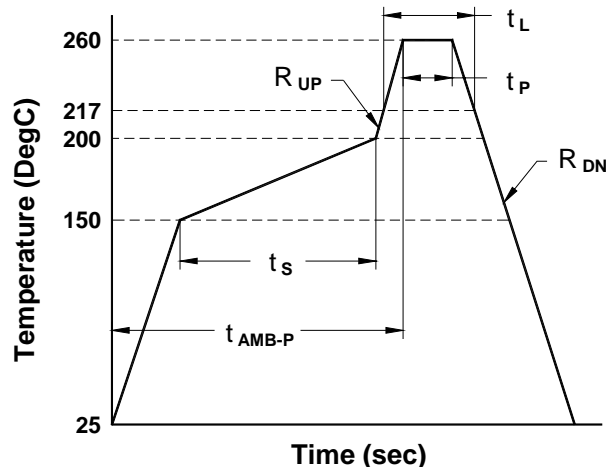

VS-550 Voltage Controlled SAW Oscillator

| Standard Frequencies (MHz) | | | | | | | | | | | |
|----------------------------|-----------|----------|-----------|----------|-----------|----------|-----------|----------|-----------|----------|-----------|
| 622.0800 | P2 | 625.0000 | P3 | 644.5313 | P4 | 657.4219 | PB | 666.5143 | P5 | 669.3266 | R3 |
| 672.1627 | R5 | 690.5692 | R4 | 693.4830 | R6 | | | | | | |
| | | | | | | | | | | | |

1. For other frequencies, we recommend the VS-751, please contact VI for details.
2. Frequency 1 must be lower than Frequency 2. Not all combinations are available.

Ordering Information

VS - 550 - L F F - H N N - P2 - P4

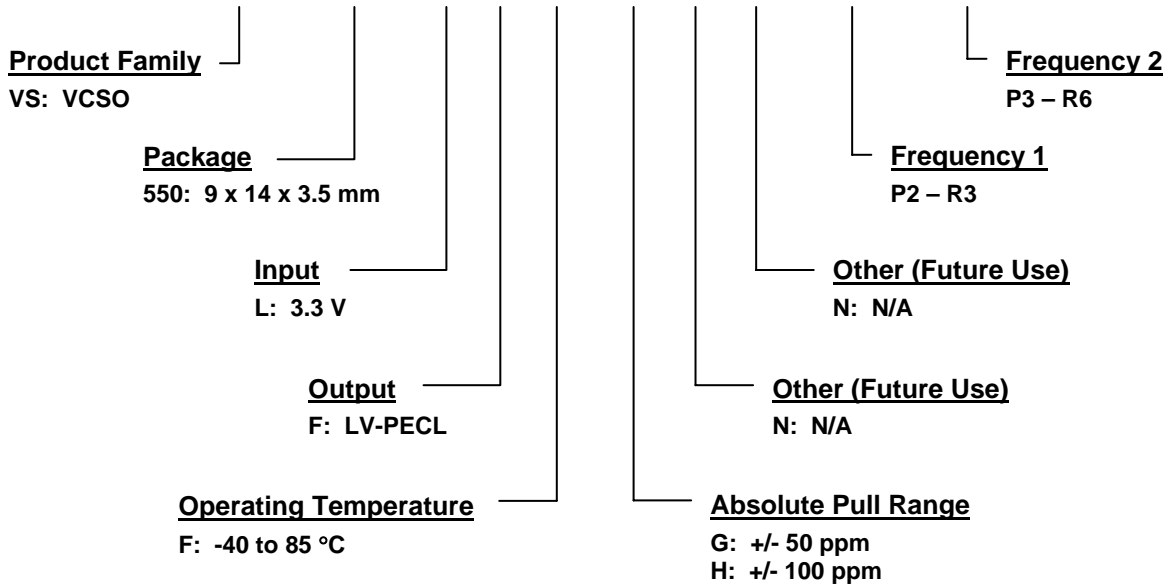

For Additional Information, Please Contact:



USA: Vectron International, 267 Lowell Rd, Hudson, NH 03051 Tel: 1-88-VECTRON-1 Fax: 1-888-FAX-VECTRON
 EUROPE: Tel: +49 (0) 3328-4784-17 Fax: +49 (0) 3328-4784-30
 ASIA: Tel: +86-21-28909740 Fax: +86-21-28909240

Vectron International reserves the right to make changes to the product(s) and or information contained herein without notice. No liability is assumed as a result of their use or application. No rights under any patent accompany the sale of any such product(s) or information.