

iC-OD, iC-ODL

OPTICAL POSITION-SENSITIVE DETECTOR (PSD)



Rev D4, Page 1/11

FEATURES

- Low-noise current amplifier with an integrated position-sensitive photodiode
- High reliability due to monolithical design
- Effective photodiode area: 2.6 mm x 0.88 mm (iC-OD) resp. 8.4 mm x 0.88 mm (iC-ODL)
- High sensitivity for visible light and near infrared
- Integrated bandpass filter with 100 kHz center frequency
- High background light suppression
- Analogue current source output
- Minimum external circuitry required
- Low power consumption from 3.9 to 13.2 V supply voltage

APPLICATIONS

- Position-sensitive detection of pulse lights
- Receiver for motion or proximity sensors

PACKAGES

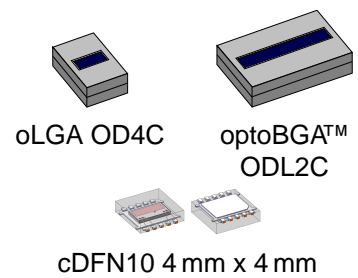

BLOCK DIAGRAM

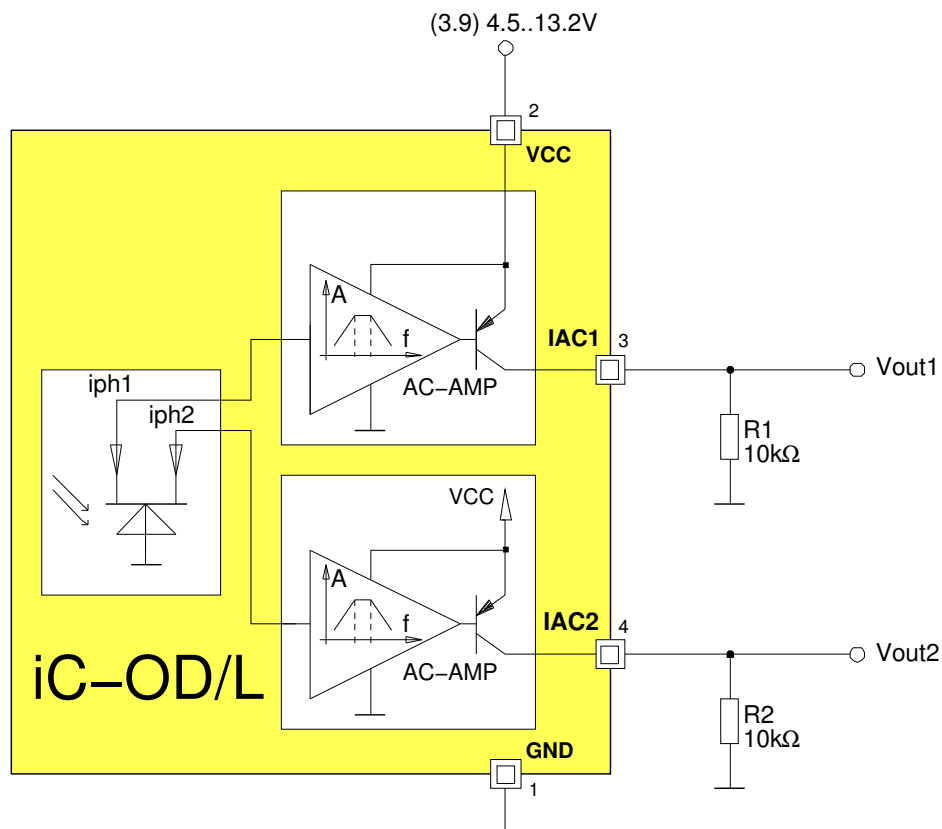

Pin numbers given for iC-OD oLGA OD4C

iC-OD, iC-ODL

OPTICAL POSITION-SENSITIVE DETECTOR (PSD)



Rev D4, Page 2/11

DESCRIPTION

The iC-OD/L device is an optical position sensitive detector with a monolithic integrated photodiode. The device supersedes one PSD and two conventional photoelectric detectors, e.g. in motion sensors.

Constant light and low-frequency varying light are suppressed by a highpass filter. A lowpass filter reduces high-frequency interference to a minimum.

The maximum sensitivity for alternating-light signals (for AC photoelectric currents) is about 100 kHz, with a current amplification of typically 48 dB.

The photoelectric current is partitioned to the two photocurrent amplifiers according to the position of the light signal. The analogue outputs IAC1 and IAC2 offer directly the amplified AC photoelectric current.

iC-OD, iC-ODL

OPTICAL POSITION-SENSITIVE DETECTOR (PSD)



Rev D4, Page 3/11

PACKAGES

PIN CONFIGURATION OLGA OD4C

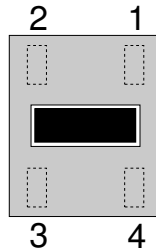

PIN FUNCTIONS

No. Name Function

- 1 GND Ground
- 2 VCC +(3.9)4.5 to +13.2 V Supply Voltage
- 3 IAC1 Current Output 1
- 4 IAC2 Current Output 2

PIN CONFIGURATION cDFN10 4 mm x 4 mm

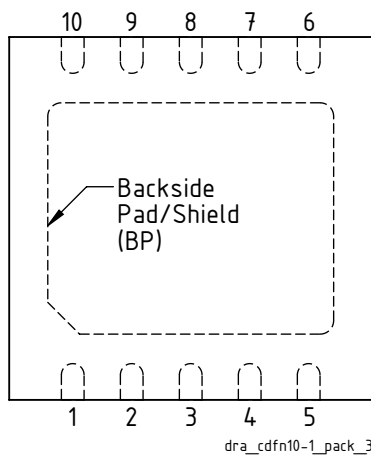

PIN FUNCTIONS

No. Name Function

- 1 VCC +(3.9)4.5 to +13.2 V Supply Voltage
- 2 IAC1 Current Output 1
- 3 n/c
- 4 IAC2 Current Output 2
- 5 GND Ground
- 6 n/c
- 7 n/c
- 8 n/c
- 9 n/c
- 10 n/c

PIN CONFIGURATION OBGA™ ODL2C

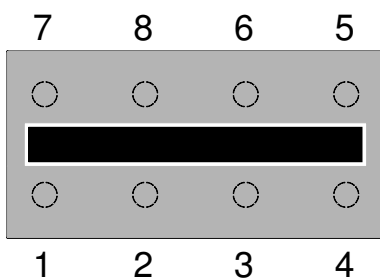

PIN FUNCTIONS

No. Name Function

- 1 VCC +(3.9)4.5 to +13.2 V Supply Voltage
- 2 IAC1 Current Output 1
- 3 IAC2 Current Output 2
- 4 GND Ground
- 5 n.c.
- 6 n.c.
- 7 n.c.
- 8 n.c.

iC-OD, iC-ODL

OPTICAL POSITION-SENSITIVE DETECTOR (PSD)



Rev D4, Page 4/11

PACKAGE DIMENSIONS

cDFN10 4 mm x 4 mm

RECOMMENDED PCB-FOOTPRINT

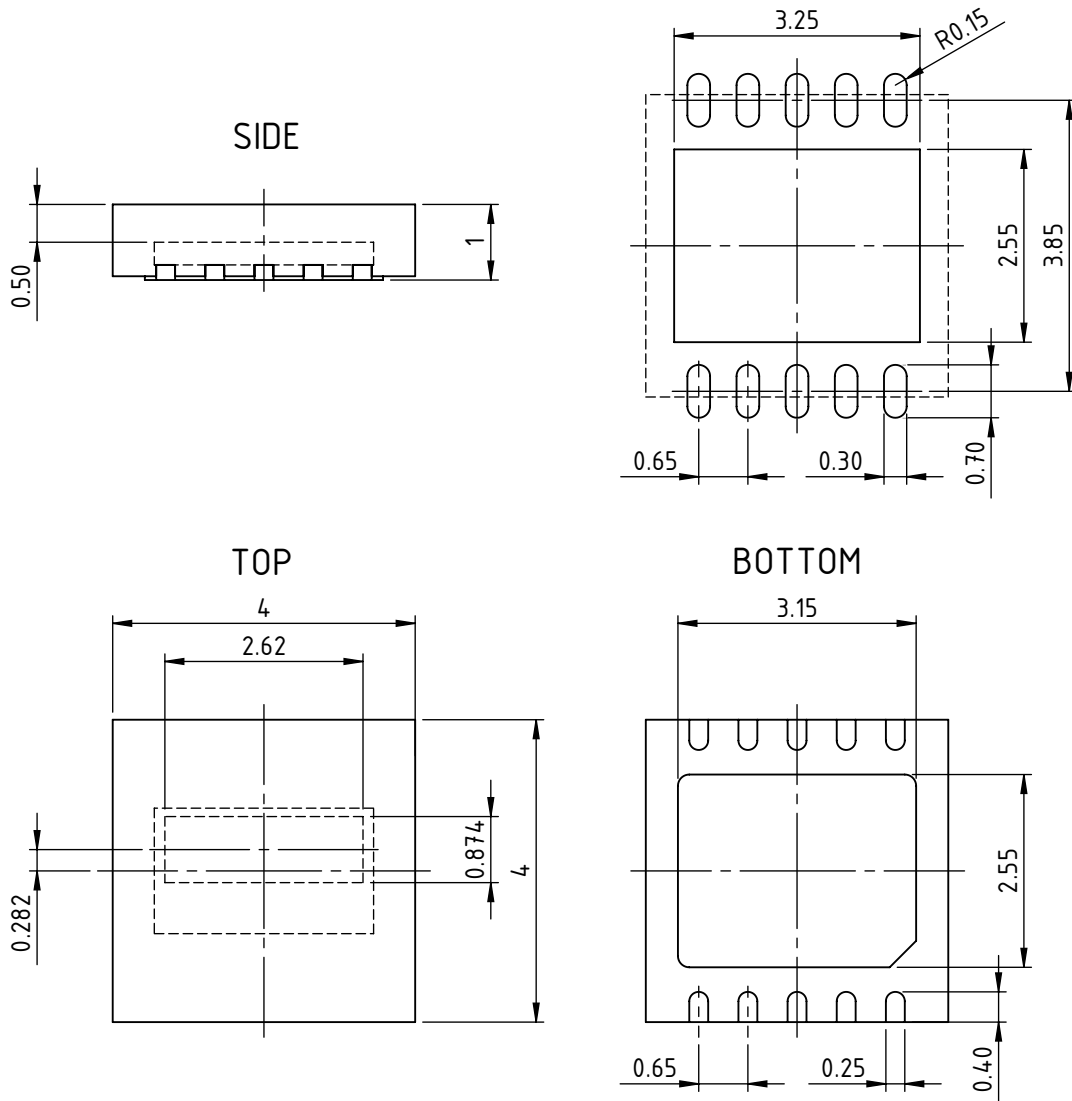

dra_od4-cdfn10-1_pack_1, 10:1

CHIP LAYOUT iC-OD

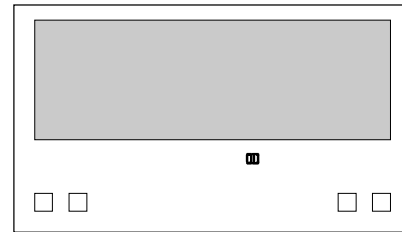

VCC IAC1 IAC2 GND

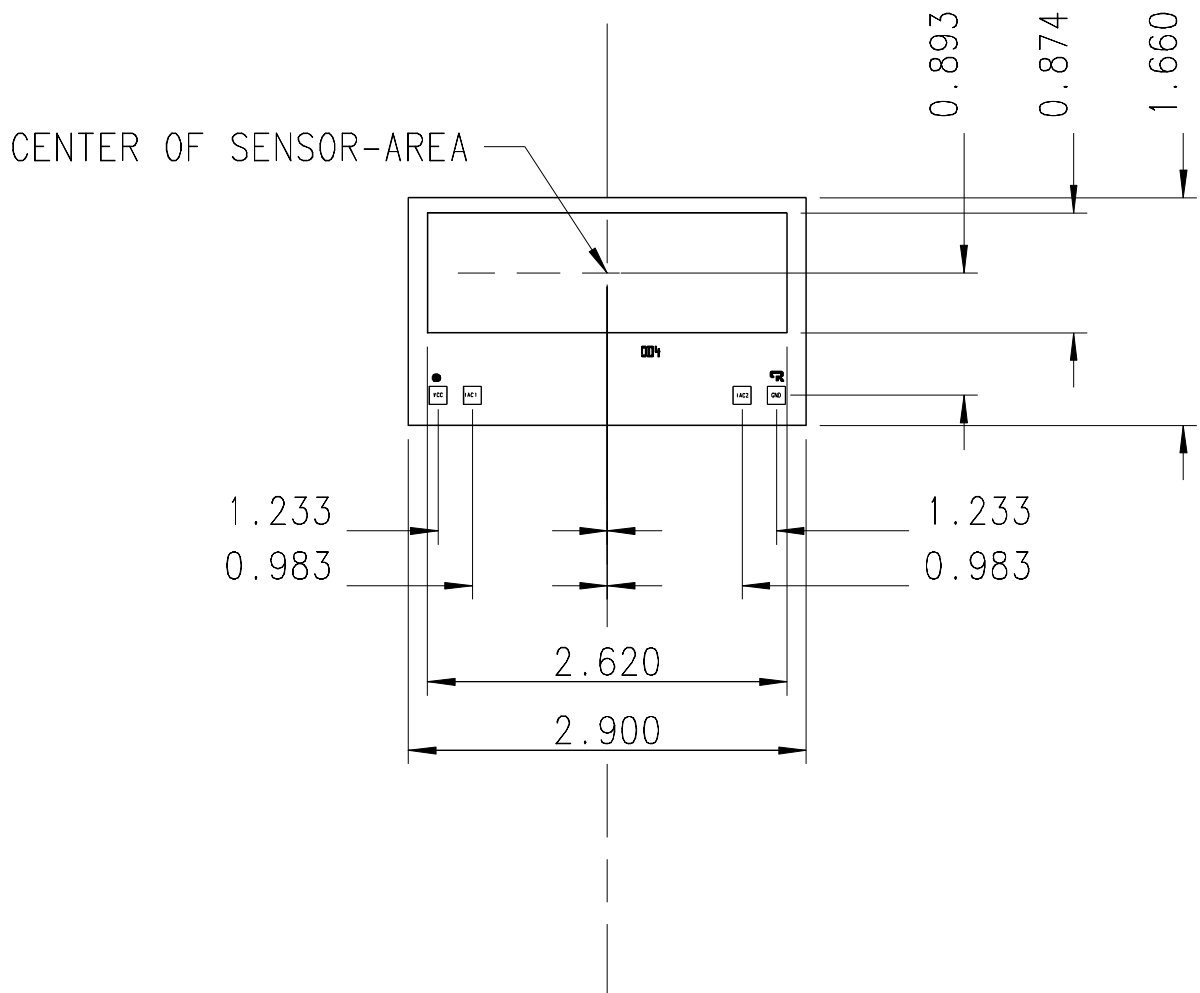

iC-OD, iC-ODL

OPTICAL POSITION-SENSITIVE DETECTOR (PSD)



Rev D4, Page 6/11

CHIP LAYOUT iC-ODL

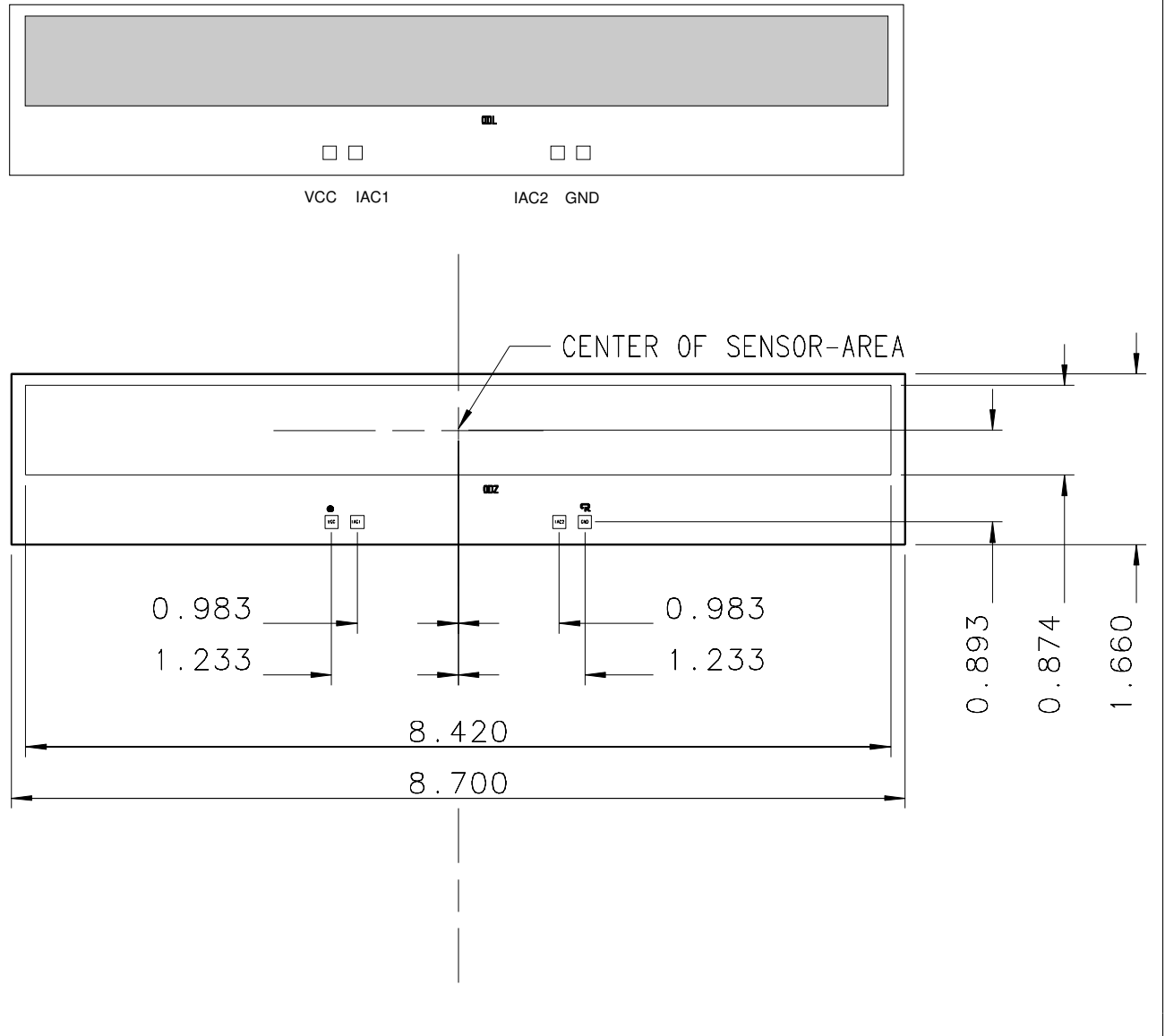

iC-OD, iC-ODL

OPTICAL POSITION-SENSITIVE DETECTOR (PSD)



Rev D4, Page 7/11

ABSOLUTE MAXIMUM RATINGS

Beyond these values damage may occur; device operation is not guaranteed.

Item No.	Symbol	Parameter	Conditions	Min. Max.		Unit
				Min.	Max.	
G001	VCC	Supply Voltage		0	15	V
G002	I()	Current in IAC1, IAC2		-1	0	mA
G003	Tj	Junction Temperature		-40	130	°C
G004	Ts	Storage Temperature	see package specifications			

THERMAL DATA

Operating Conditions: VCC = 4.5...13.2V

Item No.	Symbol	Parameter	Conditions	Min. Typ. Max.			Unit
				Min.	Typ.	Max.	
T01	Ta	Operating Ambient Temperature Range	cDFN10 oLGA OD4C and oBGA ODL2C, see package specifications	0		70	°C

All voltages are referenced to ground unless otherwise stated.

All currents flowing into the device pins are positive; all currents flowing out of the device pins are negative.

iC-OD, iC-ODL

OPTICAL POSITION-SENSITIVE DETECTOR (PSD)



Rev D4, Page 8/11

ELECTRICAL CHARACTERISTICS

Operating Conditions: VCC = 4.5...13.2 V, $\lambda = 880$ nm, Tj = -25...85 °C, unless otherwise noted

Item No.	Symbol	Parameter	Conditions				Unit
				Min.	Typ.	Max.	
Total Device							
001	VCC	Permissible Supply Voltage VCC	Tj = -25...85 °C Tj = 0...60 °C	4.5 3.9		13.2 13.2	V V
002	I(VCC)	Supply Current in VCC	iph = 0 Tj = 27 °C	0.55	0.95	2.4	mA mA
003	Vs()	Saturation Voltage at IAC1, IAC2	Vs() = VCC - V(); I() = -400 μ A			0.5	V
004	I()	Output Bias Current in IAC1, IAC2	iph = 0 Tj = 27 °C	-210	-108		μ A μ A
Photodiode							
101	S(λ) _{max}	Spectral Sensitivity			0.5		A/W
102	λ_{ar}	Range of Spectral Sensitivity	Se(λ_{ar}) = 0.1 x S(λ) _{max}	500		1050	nm
103	A _{ph} ()	Radiant Sensitive Area iC-OD		2.63 x 0.88			mm ²
104	A _{ph} ()	Radiant Sensitive Area iC-ODL		8.42 x 0.88			mm ²
Photo Current Amplifier IAC1, IAC2							
201	I()	Output Current Operating Range in IAC1, IAC2		-500		0	μ A
202	Pe() _{pk}	Permissible Irradiance for Alternating Light (peak value)	f = fc; iC-OD iC-ODL			2.2 0.7	μ W μ W
203	ISUM	Sum of Output Currents (RMS)	ISUM = I(IAC1) + I(IAC2); f = fc, Ee() _{ac} = 30 μ W/cm ² Tj = 27 °C	-25	-50		μ A μ A
204	iph() _{dc}	DC Photo Current Capability	Position of light spot arbitrary Tj = -25...85 °C Tj = 0...60 °C Tj = 27 °C, position of light spot centered	2.7 4.5	16		μ A μ A μ A
205	Ev() _{dc}	Permissible Ambient Light Level	Standard Illuminant A at T = 2856 K; iC-OD iC-ODL		250 75		lx lx
206	fc	Bandpass Center Frequency			100		kHz
207	Q	Filter Q-Factor	Q = fc / (f _{hc} - f _{lc})	0.35	0.5	0.52	
208	I()/ISUM	Single Amplifier Output Current to Sum of Output Currents	f = fc, position of light spot centered	0.40		0.60	
209	I() _{min} /ISUM	Smaller Output Current to Sum of Output Currents	f = fc, position of light spot 1 mm out of center	0.13		0.18	
210	Ai() _{fc}	Photo Current Gain for Alternating Light	Ai() _{fc} = ISUM / (iph1 + iph2); f = fc, position of light spot centered	44	48	52	dB
211	dAi() _{fc}	Change of Photo Current Gain	f = fc, position of light spot 1 mm out of center	-10		10	%
212	Ai() ₁₀₀	Low-Frequency Photo Current Gain	f = 100 Hz	1	3	6	dB
213	Vn(Vout)	RMS Noise Voltage	With external filter: R1, R3 = 10 k Ω , C1, C3 = 120 pF, R2, R4 = 50 k Ω , C2, C4 = 100 pF (see Fig. 6)		2.1	2.8	mV
214	t _{on} (VCC)	Power-on Setup Time	Tj = 27 °C		30	50	μ s μ s
215	t _{on} (VCC)	Power-on Setup Time	VCC = 0 \rightarrow 4 V; Tj = 0...60 °C Tj = 27 °C		70	100	μ s μ s

TYPICAL CHARACTERISTICS

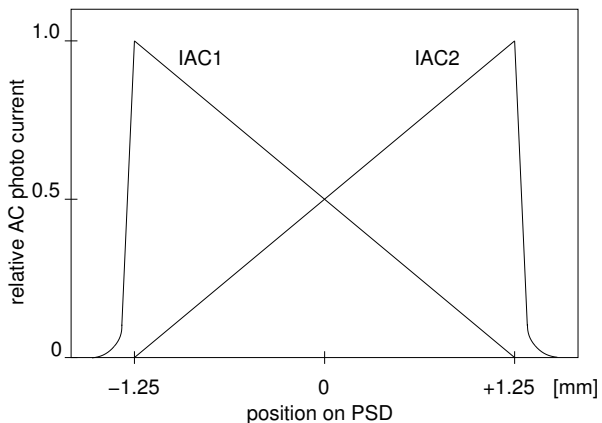

Figure 1: Example for position sensing characteristics

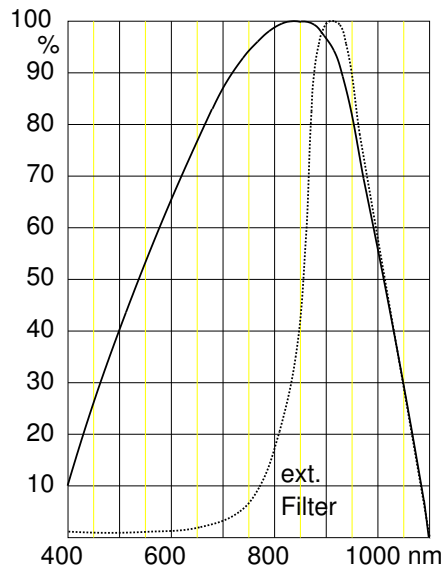

Figure 2: Relative spectral sensitivity

External filter (RG850) improves the suppression of ambient light by a factor of ca. 20 to 30.

APPLICATIONS INFORMATION

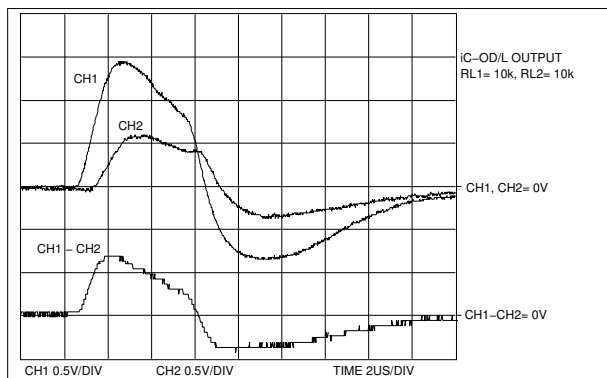

Figure 3: The light spot impinges to the left

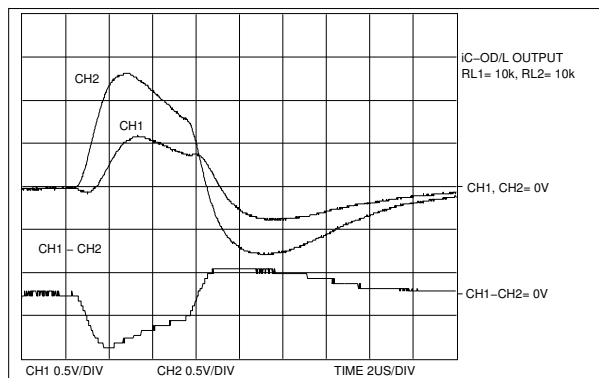

Figure 5: The light spot impinges to the right

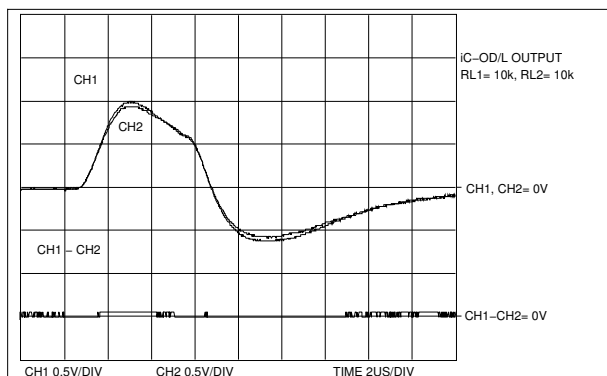

Figure 4: The light spot impinges in the center

Examples of output signals

The oscilloscope pictures show the signal patterns at iC-OD outputs IAC1 and IAC2 when receiving a 5 μ s light pulse. The differential signal shown has been calculated. Both of the outputs are terminated with 10 k Ω . An external filter is not used.

Example: external filter

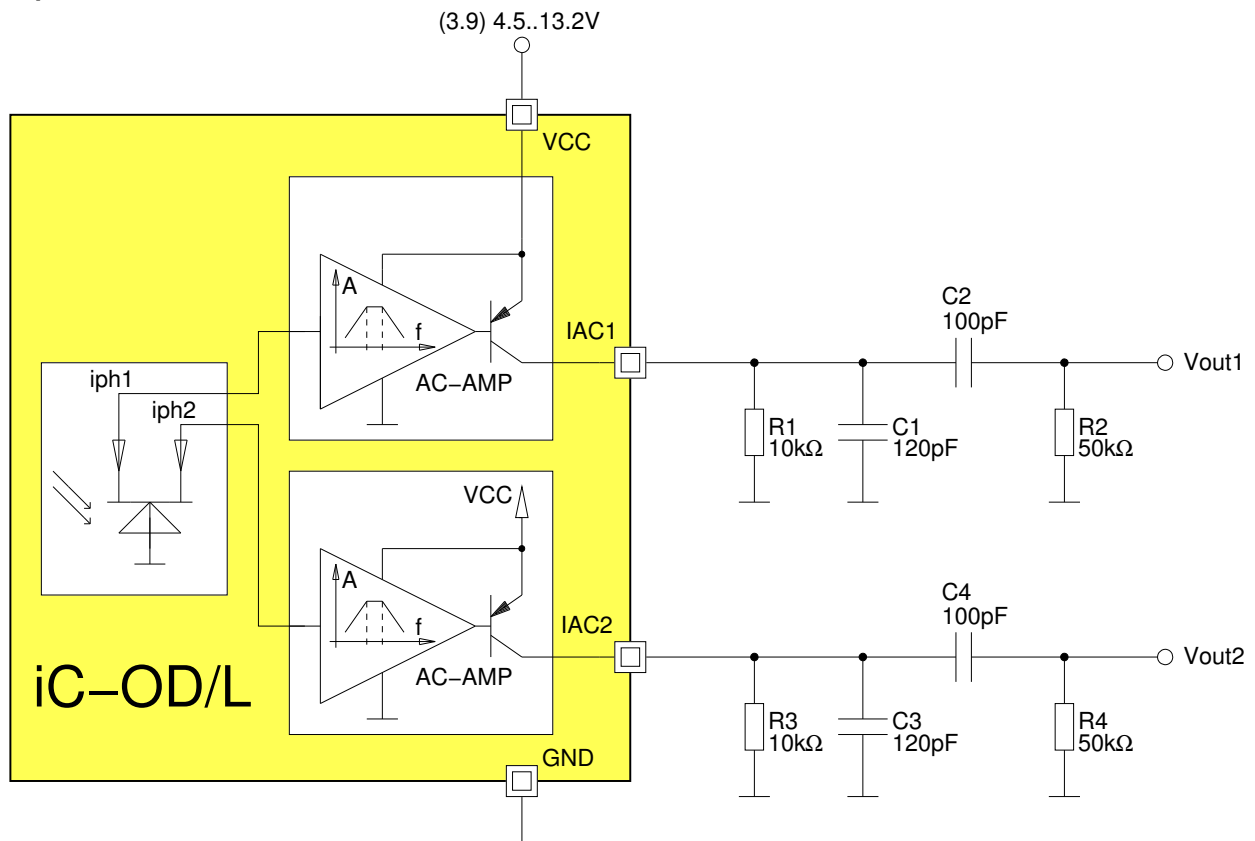

Figure 6: External filter to detach the DC-portion and to reduce the noise

iC-Haus expressly reserves the right to change its products and/or specifications. An info letter gives details as to any amendments and additions made to the relevant current specifications on our internet website www.ichaus.de/infoletter; this letter is generated automatically and shall be sent to registered users by email.

Copying – even as an excerpt – is only permitted with iC-Haus' approval in writing and precise reference to source.

iC-Haus does not warrant the accuracy, completeness or timeliness of the specification and does not assume liability for any errors or omissions in these materials.

The data specified is intended solely for the purpose of product description. No representations or warranties, either express or implied, of merchantability, fitness for a particular purpose or of any other nature are made hereunder with respect to information/specification or the products to which information refers and no guarantee with respect to compliance to the intended use is given. In particular, this also applies to the stated possible applications or areas of applications of the product.

iC-Haus conveys no patent, copyright, mask work right or other trade mark right to this product. iC-Haus assumes no liability for any patent and/or other trade mark rights of a third party resulting from processing or handling of the product and/or any other use of the product.

As a general rule our developments, IPs, principle circuitry and range of Integrated Circuits are suitable and specifically designed for appropriate use in technical applications, such as in devices, systems and any kind of technical equipment, in so far as they do not infringe existing patent rights. In principle the range of use is limitless in a technical sense and refers to the products listed in the inventory of goods compiled for the 2008 and following export trade statistics issued annually by the Bureau of Statistics in Wiesbaden, for example, or to any product in the product catalogue published for the 2007 and following exhibitions in Hanover (Hannover-Messe).

We understand suitable application of our published designs to be state-of-the-art technology which can no longer be classed as inventive under the stipulations of patent law. Our explicit application notes are to be treated only as mere examples of the many possible and extremely advantageous uses our products can be put to.

iC-OD, iC-ODL

OPTICAL POSITION-SENSITIVE DETECTOR (PSD)



Rev D4, Page 11/11

ORDERING INFORMATION

Type	Package	Order Designation
iC-OD	- OLGA OD4C cDFN10 4 mm x 4 mm	iC-OD chip iC-OD oLGA OD4C iC-OD cDFN10
iC-ODL	- OBGA™ ODL2C	iC-ODL chip iC-ODL oBGA ODL2C

For technical support, information about prices and terms of delivery please contact:

iC-Haus GmbH
Am Kuemmerling 18
D-55294 Bodenheim
GERMANY

Tel.: +49 (61 35) 92 92-0
Fax: +49 (61 35) 92 92-192
Web: <http://www.ichaus.com>
E-Mail: sales@ichaus.com

Appointed local distributors: http://www.ichaus.com/sales_partners