



**Product Features:**

Low Jitter, Non-PLL Based Output  
 Available in Both Clipped Sinewave and  
 HCMOS Output Levels  
 Compatible with Leadfree Processing

**Applications:**

Server & Storage  
 Sonet /SDH  
 802.11 / Wifi  
 T1/E1, T3/E3  
 Fibre Channel

<b>Frequency</b>	8.000 Mhz to 40 Mhz
<b>Output Level</b> Clipped Sinewave HCMOS	0.8 V p-p Min. '0'=0.5 VDC Max., '1'=0.8Vcc Min.
<b>Output Load</b> Clipped Sinewave HCMOS	20K Ohms / 10 pF 15pF
<b>Duty Cycle (HCMOS)</b>	50% ±10%
<b>Rise / Fall Time (HCMOS)</b>	10 nS Max.
<b>Frequency Stability Vs Temperature Vs Voltage Vs Load(5%)</b>	See Frequency Stability Table ± 0.3 ppm Max. ±0.2 ppm Max.
<b>Frequency Tolerance @ 25° C</b>	± 1.0 ppm
<b>Aging</b>	± 1 ppm / Year Max.
<b>Supply Voltage</b>	See Supply Voltage Table , tolerance ± 5%
<b>Current</b>	2.0 mA Max. (Clipped Sinewave) 6.0 mA Max. (HCMOS)
<b>Voltage Control (I737/I738)</b>	1.5 VDC ± 1.0 VDC, ± 5.0 ppm Min.
<b>Operating</b>	See Operating Temperature Table
<b>Storage</b>	-40° C to +85° C
<b>Phase Noise (Typ. @ 20 Mhz)</b>	-86 dBc/Hz @ 10 Hz -115 dBc/Hz @ 100 Hz -138 dBc/Hz @ 1KHz -146 dBc/Hz @ 10 KHz

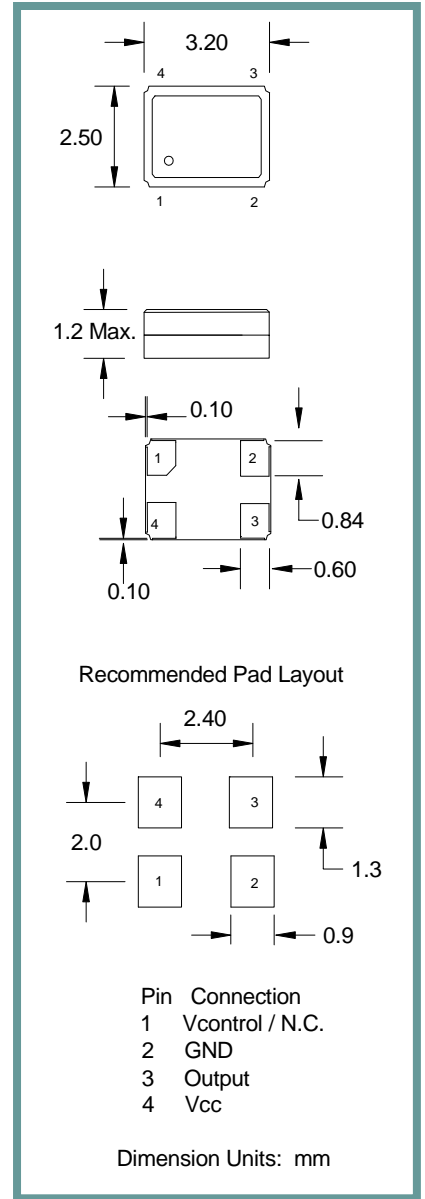

Part Number Guide		Sample Part Number: I537-1Q3-20.000 Mhz		
Package	Operating Temperature	Frequency Stability vs Temperature	Supply Voltage	Frequency
I537 (Clipped Sinewave TCXO)	7 = 0° C to +50° C	**N = ±1.0 ppm	3 = 3.3 V	- 20.000 MHz
I538 (HCMOS TCXO)	1 = 0° C to +70° C	**O = ±1.5 ppm	7 = 3.0 V	
I737 (Clipped Sinewave TCVCXO)	3 = -20° C to +70° C	**P = ±2.0 ppm	2 = 2.7 V	
I738 (HCMOS TCVCXO)	2 = -40° C to +85° C	Q = ±2.5 ppm R = ±3.0 ppm J = ±5.0 ppm		

NOTE: A 0.01 µF bypass capacitor is recommended between Vcc (pin 4) and GND (pin 2) to minimize power supply noise.  
 \*\* Not available for all temperature ranges.



2.5 mm x 3.2 mm Ceramic Package SMD TCXO



I537/I538/I737/I738 Series

### Pb Free Solder Reflow Profile:

### Typical Application:

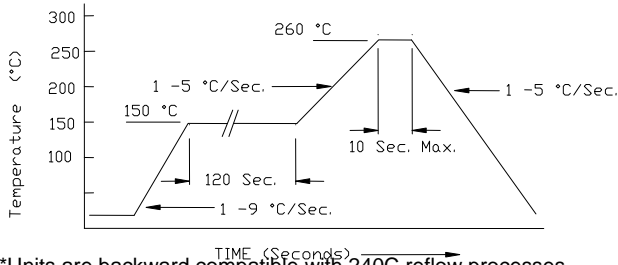

\*Units are backward compatible with 240C reflow processes

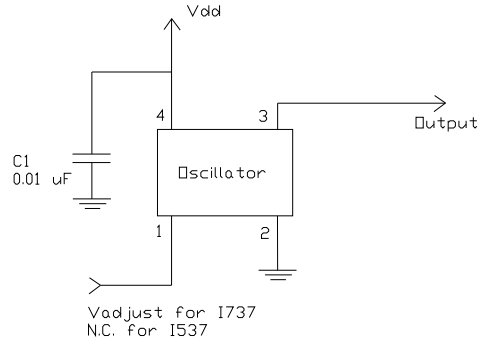

### Package Information:

MSL = N.A. (package does not contain plastic, storage life is unlimited under normal room conditions).  
Termination = e4 (Au over Ni over W base metalization).

### Tape and Reel Information:

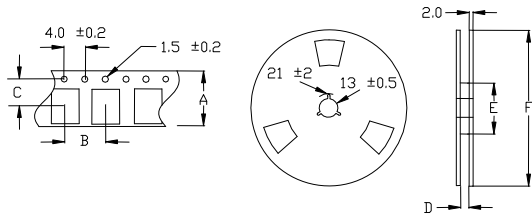

Quantity per Reel	1000
A	8 +/- .3
B	4 +/- .2
C	3.5 +/- .2
D	9 +/- .1 or 12 +/- .3
E	60 / 80
F	180

### Environmental Specifications

Thermal Shock	MIL-STD-883, Method 1011, Condition A
Moisture Resistance	MIL-STD-883, Method 1004
Mechanical Shock	MIL-STD-883, Method 2002, Condition B
Mechanical Vibration	MIL-STD-883, Method 2007, Condition A
Resistance to Soldering Heat	J-STD-020C, Table 5-2 Pb-free devices (except 2 cycles max)
Hazardous Substance	Pb-Free / RoHS / Green Compliant
Solderability	JESD22-B102-D Method 2 (Preconditioning E)
Terminal Strength	MIL-STD-883, Method 2004, Test Condition D
Gross Leak	MIL-STD-883, Method 1014, Condition C
Fine Leak	MIL-STD-883, Method 1014, Condition A2, R1=2x10 <sup>-8</sup> atm cc/s
Solvent Resistance	MIL-STD-202, Method 215

### Marking

Line 1: I - Date Code (YWW)

Line 2: Frequency