

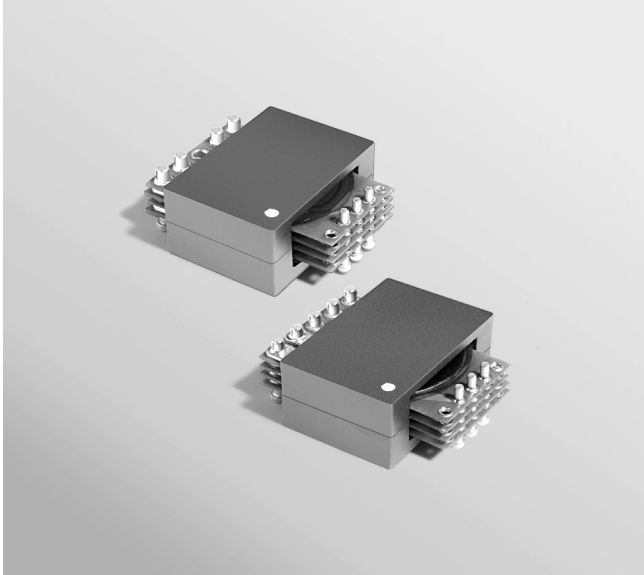

# SMT Planar Transformers

For Applications  
up to 140 Watts



The PL140 surface mount planar transformers are rated for 140 Watts and are designed to operate between 200 kHz and 500 kHz. They are available in 15 turns ratios and six different schematics, and may be special ordered with an auxiliary winding.

These transformers are ideal for use in high-current power supply applications such as open loop intermediate bus converters (IBC) and closed loop voltage mode converters. They are designed for use with nominal -48 V input. Output voltages depend on the turns ratio, duty cycle and circuit topology. They offer high efficiency and feature excellent DCR, very low leakage inductance and 1500 Vdc primary to secondary isolation.

Coilcraft can custom design planar transformers with different turns ratios to meet your specific requirements.

Coilcraft **Designer's Kit C390** contains two samples each of the parts shown in bold. To order, contact Coilcraft, or visit <http://order.coilcraft.com> to purchase on-line.

Part number <sup>1</sup>	Primary turns		Schem.	Primary inductance <sup>2</sup>		Leakage inductance <sup>3</sup>	DCR max (mOhms)	
	N <sub>1</sub>	N <sub>2</sub>		min (μH)	max (μH)		Primary	Secondary
<b>PL140-100L</b>	4	4	A	120.0	0.35	12.0 (2-3), 12.0 (3-4)	4.0 (6-10)	
PL140-101L	9	–	B	152.0	0.35	32.8 (2-4)	4.0 (6-10)	
PL140-102L	5	5	A	188.0	0.35	20.8 (2-3), 20.8 (3-4)	4.0 (6-10)	
PL140-103L	11	–	B	227.0	0.35	48.8 (2-4)	4.0 (6-10)	
<b>PL140-104L</b>	6	6	A	270.0	0.45	28.0 (2-3), 28.0 (3-4)	4.0 (6-10)	
<b>PL140-105L</b>	4	4	C	120.0	0.35	12.0 (2-3), 12.0 (3-4)	0.5 (6-7), 0.5 (9-10)	
PL140-106L	9	–	D	152.0	0.35	32.8 (2-4)	0.5 (6-7), 0.5 (9-10)	
PL140-107L	5	5	C	188.0	0.35	20.8 (2-3), 20.8 (3-4)	0.5 (6-7), 0.5 (9-10)	
PL140-108L	11	–	D	227.0	0.50	48.8 (2-4)	0.5 (6-7), 0.5 (9-10)	
<b>PL140-109L</b>	6	6	C	270.0	0.60	28.0 (2-3), 28.0 (3-4)	0.5 (6-7), 0.5 (9-10)	
<b>PL140-110L</b>	4	4	E	120.0	0.35	12.0 (2-3), 12.0 (3-4)	1.0 (6-8), 1.0 (9-10)	
PL140-111L	9	–	F	152.0	0.35	32.8 (2-4)	1.0 (6-8), 1.0 (9-10)	
PL140-112L	5	5	E	188.0	0.35	20.8 (2-3), 20.8 (3-4)	1.0 (6-8), 1.0 (9-10)	
PL140-113L	11	–	F	227.0	0.35	48.8 (2-4)	1.0 (6-8), 1.0 (9-10)	
<b>PL140-114L</b>	6	6	E	270.0	0.45	28.0 (2-3), 28.0 (3-4)	1.0 (6-8), 1.0 (9-10)	

1. When ordering, please specify **packaging** code:

**PL140-114LD**

**Packaging:** **D** = 13" machine-ready reel. EIA-481 embossed plastic tape (200 parts per full reel).

**B** = Less than full reel. In tape, but not machine ready. To have a leader and trailer added (\$25 charge), use code letter D instead.

To order a transformer with an optional **auxiliary winding**, add an "X" and the turn count after the PL140, e.g. PL140X3-100LB. Turn counts of 2, 3, 4, 5, 7 and 9 are available for the auxiliary winding. Transformers with auxiliary windings are not stocked.

- Inductance measured on an Agilent/HP 4284 between pins 2 and 4 at 200 kHz, 0.1 Vrms, 0 Adc.
- Leakage inductance measured between pins 2 and 4 at 100 kHz, 0.1 Vrms, 0 Adc with all secondary pins shorted.
- Storage and ambient operating temperature range: -40°C to +85°C.
- Electrical specifications at 25°C.

## Schematics

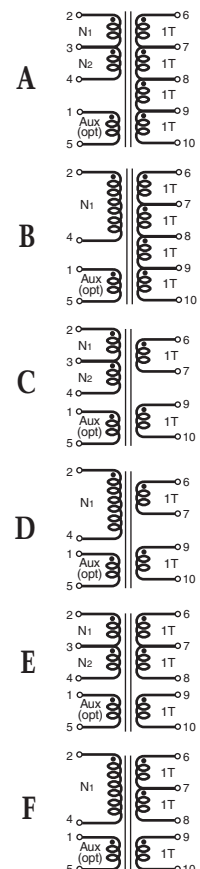

**Coilcraft**<sup>®</sup>

Specifications subject to change without notice.  
Please check our website for latest information.

Document 417-1 Revised 03/11/11

1102 Silver Lake Road Cary, Illinois 60013 Phone 847/639-6400 Fax 847/639-1469

E-mail [info@coilcraft.com](mailto:info@coilcraft.com) Web <http://www.coilcraft.com>



# PL140 Series SMT Planar Transformers

## Dimensions

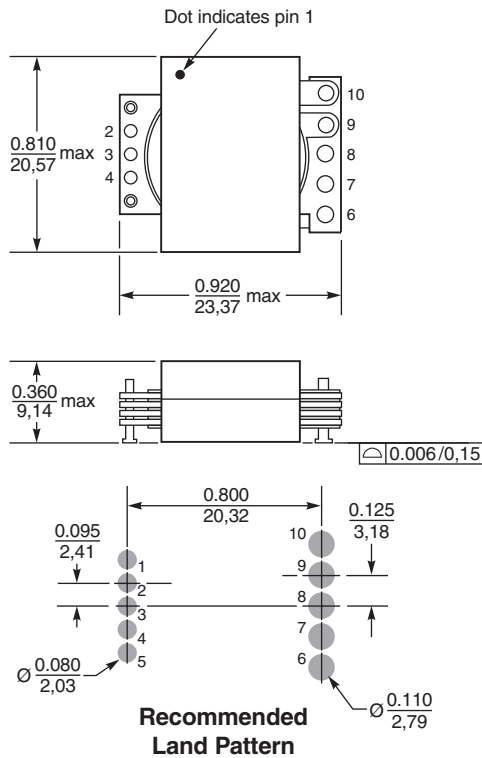

Note: Pad for pin 3 not necessary for schematics B, D and F. Pad for pin 8 is not necessary for schematics C and D. Pads 1 and 5 are only needed for optional auxiliary winding.

**Core material** Ferrite

**Terminations** Matte tin over nickel over brass. Other terminations available at additional cost.

**Weight** 10.9 – 12 g

**Ambient temperature**  $-40^{\circ}\text{C}$  to  $+85^{\circ}\text{C}$

**Storage temperature** Component:  $-40^{\circ}\text{C}$  to  $+85^{\circ}\text{C}$ .

Tape and reel packaging:  $-40^{\circ}\text{C}$  to  $+80^{\circ}\text{C}$

**Resistance to soldering heat** Max three 40 second reflows at  $+260^{\circ}\text{C}$ , parts cooled to room temperature between cycles

**Moisture Sensitivity Level (MSL)** 1 (unlimited floor life at  $<30^{\circ}\text{C}$  / 85% relative humidity)

**Failures in Time (FIT) / Mean Time Between Failures (MTBF)**

38 per billion hours / 26,315,789 hours, calculated per Telcordia SR-332

Packaging 200/13" reel Plastic tape: 44 mm wide, 0.37 mm thick, 32 mm pocket spacing, 9.35 mm pocket depth

**PCB washing** Only pure water or alcohol recommended

**Coilcraft**<sup>®</sup>

Specifications subject to change without notice.  
Please check our website for latest information.

Document 417-2 Revised 03/11/11

1102 Silver Lake Road Cary, Illinois 60013 Phone 847/639-6400 Fax 847/639-1469

E-mail [info@coilcraft.com](mailto:info@coilcraft.com) Web <http://www.coilcraft.com>