

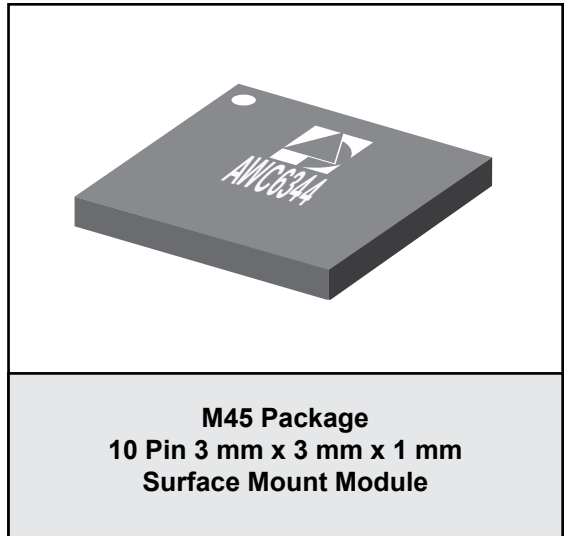

AWC6344
 HELP™ CDMA AWS/KPCS
 CDMA Power Amplifier Module
 DATA SHEET- Rev 2.2

FEATURES

- HELP™ technology
- High Efficiency (RC-1 waveform):
 - 37 % @ P_{OUT} = +28 dBm
 - 34 % @ P_{OUT} = +16.5 dBm
- Low Quiescent Current: 12 mA
- Low Leakage Current in Shutdown Mode: <5 μA
- Internal Voltage Regulator
- Integrated “daisy chainable” directional coupler with CPL_{IN} and CPL_{OUT} port
- Internal DC blocks on IN/OUT RF ports
- Optimized for a 50 Ω System
- 1.8 V Control Logic
- RoHS Compliant Package, 260 °C MSL-3



APPLICATIONS

- Band Class 4, 8 and 15

PRODUCT DESCRIPTION

The AWC6344 is a HELP™ product for CDMA devices operating in AWS/KPCS band. This PA incorporates ANADIGICS’ HELP™ technology to deliver exceptional efficiency at low power levels and low quiescent current without the need for external voltage regulators or converters. The device is manufactured using advanced InGaP HBT technology offering state-of-the-art reliability, temperature stability, and ruggedness. Two selectable bias modes that optimize efficiency for different output power levels and a shutdown mode with low leakage current increase handset talk and standby time. A “daisy chainable” directional coupler is integrated in the module, thus eliminating the need of an external coupler. The self-contained 3 mm x 3 mm x 1 mm surface mount package incorporates matching networks optimized for output power, efficiency, and linearity in a 50 Ω system.

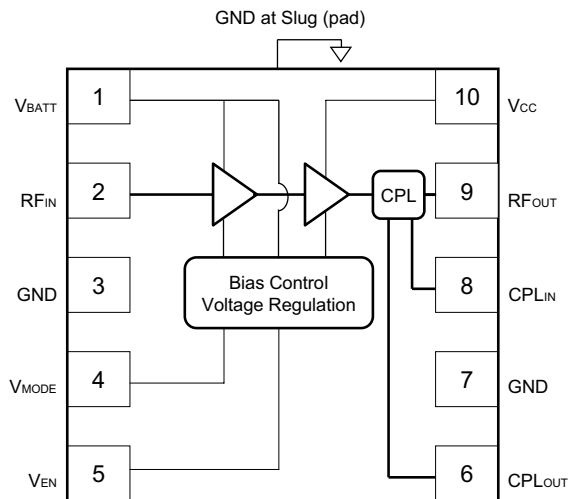

Figure 1: Block Diagram

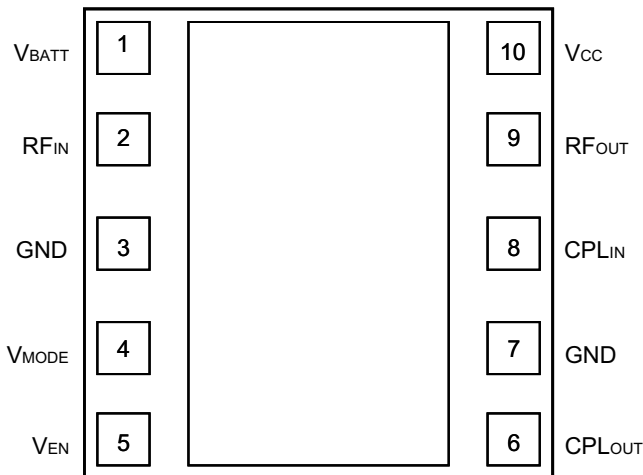

Figure 2: Pinout (X-ray Top View)

Table 1: Pin Description

PIN	NAME	DESCRIPTION
1	V_{BATT}	Battery Voltage
2	RF_{IN}	RF Input
3	GND	Ground
4	V_{MODE}	Mode Control Voltage
5	V_{EN}	PA Enable Voltage
6	CPL_{OUT}	Coupler Output
7	GND	Ground
8	CPL_{IN}	Coupler Input
9	RF_{OUT}	RF Output
10	V_{CC}	Supply Voltage

ELECTRICAL CHARACTERISTICS

Table 2: Absolute Minimum and Maximum Ratings

PARAMETER	MIN	MAX	UNIT
Supply Voltage (V_{CC})	0	+5	V
Battery Voltage (V_{BATT})	0	+6	V
Control Voltages (V_{MODE} , V_{EN})	0	+3.5	V
RF Input Power (P_{IN})	-	+10	dBm
Storage Temperature (T_{STG})	-40	+150	°C

Stresses in excess of the absolute ratings may cause permanent damage. Functional operation is not implied under these conditions. Exposure to absolute ratings for extended periods of time may adversely affect reliability.

Table 3: Operating Ranges

PARAMETER	MIN	TYP	MAX	UNIT	COMMENTS
Operating Frequency (f)	1710	-	1785	MHz	
Supply Voltage (V_{CC})	+3.2	+3.4	+4.35	V	$P_{OUT} < +28$ dBm
Enable Voltage (V_{EN})	+1.35 0	+1.8 -	+3.1 +0.5	V	PA "on" PA "shut down"
Mode Control Voltage (V_{MODE})	+1.35 0	+1.8 -	+3.1 +0.5	V	Low Bias Mode High Bias Mode
CDMA Output Power HPM LPM	27.2 ⁽¹⁾ -	28.0 16.5	- -	dBm	CDMA2000, RC-1
Case Temperature (T_C)	-30	-	+90	°C	

The device may be operated safely over these conditions; however, parametric performance is guaranteed only over the conditions defined in the electrical specifications.

Notes:

(1) For Operation at 3.1 V, P_{OUT} is derated 0.8 dB.

Table 4: Electrical Specifications - CDMA Operation (CDMA2000, RC-1 waveform)
(T_C = +25 °C, V_{BATT} = V_{CC} = +3.4 V, V_{ENABLE} = +1.8 V, 50 Ω system)

PARAMETER	MIN	TYP	MAX	UNIT	COMMENTS	
					P _{OUT}	V _{MODE}
Gain	24 17	26.5 20	30 23	dB	P _{OUT} = +28 dBm P _{OUT} = +16.5 dBm	0 V 1.8 V
Adjacent Channel Power at +1.25 MHz offset Primary Channel BW - 1.23 MHz Adjacent Channel BW = 30 kHz	- -	-51 -53	-46 -46	dBc	P _{OUT} = +28 dBm P _{OUT} = +16.5 dBm	0 V 1.8 V
Adjacent Channel Power at +1.98 MHz Primary Channel BW=1.23 MHz Adjacent Channel BW=30 kHz	- -	-55 -56	-53 -53	dBc	P _{OUT} = +28 dBm P _{OUT} = +16.5 dBm	0 V 1.8 V
Efficiency	33.5 29	37 34	- -	%	P _{OUT} = +28 dBm P _{OUT} = +16.5 dBm	0 V 1.8 V
Quiescent Current (I _{cq}) Low Bias Mode	-	9	14	mA	through V _{CC} pin	1.8 V
Mode Control Current	-	3.5	4.5	mA	through V _{MODE} pin, V _{MODE} = +1.8 V	
Enable Current	-	0.04	0.1	mA	through V _{EN} pin	
BATT Current	-	0.8	1.5	mA	through V _{BATT} pin, V _{MODE} = +1.8 V	
Leakage Current	-	<5	10	μA	V _{BATT} = +4.35 V, V _{CC} = +4.35 V V _{EN} = 0 V, V _{MODE} = 0 V	
Noise Power	- - - -	-141 -134 -134 -145	-138 - - -	dBm/Hz	2110 MHz to 2155 MHz 1805 MHz to 1880 MHz GPS Band ISM Band	
Harmonics 2fo 4fo	- -	-44 -55	-35 -42	dBc	P _{OUT} ≤ +28 dBm	
Coupling Factor	-	20.5	-	dB		
Directivity	-	20	-	dB		
Daisy Chain Insertion Loss	-	0.25	-	dB		
Spurious Output Level (all spurious outputs)	-	-	-70	dBc	P _{OUT} < +28 dBm, In-Band VSWR <5:1, Out-Of-Band VSWR< 10:1 Applies to all operating conditions	
Load mismatch stress with no permanent degradation or failure	8:1	-	-	VSWR	Applies over full operating range	

Notes:

(1) ACLR and Efficiency limits are applied at mid-band.

APPLICATION INFORMATION

To ensure proper performance, refer to all related Application Notes on the ANADIGICS web site: <http://www.anadigics.com>

Shutdown Mode

The power amplifier may be placed in a shutdown mode by applying logic low levels (see Operating Ranges table) to the V_{EN} and V_{MODE} voltages.

Bias Modes

The power amplifier may be placed in either Low or High Bias modes by applying the appropriate logic level (see Operating Ranges table) to the V_{MODE} pin.

The Bias Control table below lists the recommended modes of operation for various applications.

Two operating modes are recommended to optimize current consumption. High Bias/High Power operating mode is for P_{OUT} levels ≥ 16 dBm. At about 16 dBm, the PA could be switched to Low Power Mode.

Table 5: Bias Control

APPLICATION	P_{OUT} LEVELS	BIAS MODE	V_{EN}	V_{MODE}	V_{CC}	V_{BATT}
Low power	$\leq +16$ dBm	Low	+1.8 V	+1.8 V	3.2 - 4.35 V	> 3.2 V
High power	$> +16$ dBm	High	+1.8 V	0 V	3.2 - 4.35 V	> 3.2 V
Shutdown	-	Shutdown	0 V	0 V	3.2 - 4.35 V	> 3.2 V

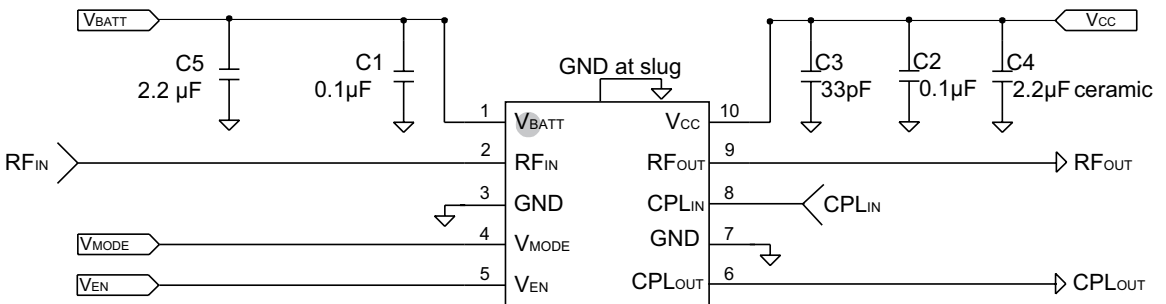
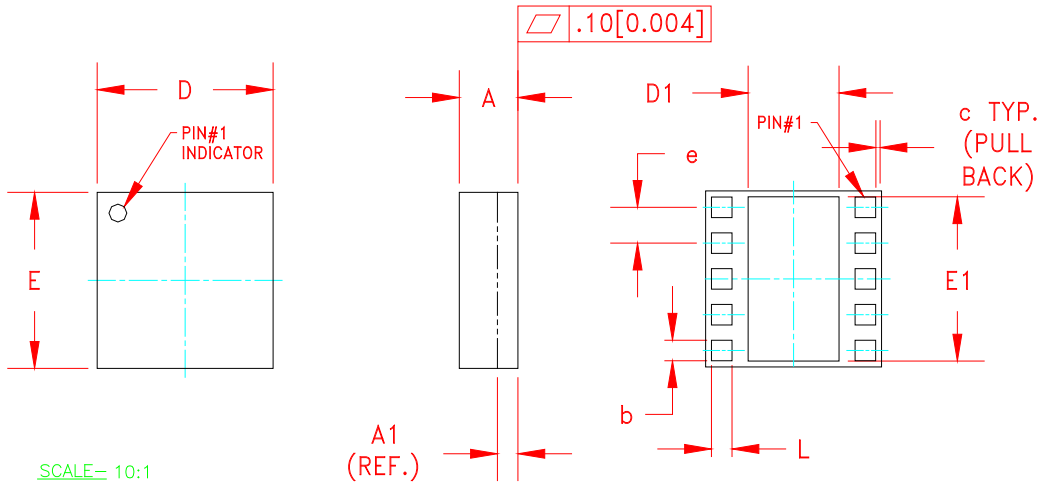

Figure 3: Evaluation Board Schematic

PACKAGE OUTLINE



SYMBOL	MILLIMETERS			INCHES			NOTE
	MIN.	NOM.	MAX.	MIN.	NOM.	MAX.	
A	0.91	1.03	1.13	0.035	0.041	0.044	—
A1	PLEASE REFER TO LAMINATE CONTROL DRAWING						—
b	0.32	0.35	0.40	0.013	0.014	0.016	3
c	—	0.10	—	—	0.004	—	—
D	2.88	3.00	3.12	0.113	0.118	0.123	—
D1	1.45	1.50	1.57	0.057	0.059	0.062	3
E	2.88	3.00	3.12	0.113	0.118	0.123	—
E1	2.70	2.75	2.85	0.106	0.108	0.112	3
e	0.60			0.024			3
L	0.32	0.35	0.40	0.013	0.014	0.016	3

NOTES:

1. CONTROLLING DIMENSIONS: MILLIMETERS
2. UNLESS SPECIFIED TOLERANCE=±0.076[0.003].
3. PADS (INCLUDING CENTER) SHOWN UNIFORM SIZE FOR REFERENCE ONLY. ACTUAL PAD SIZE AND LOCATION WILL VARY WITHIN MIN. AND MAX. DIMENSIONS ACCORDING TO SPECIFIC LAMINATE DESIGN.
4. UNLESS SPECIFIED DIMENSIONS ARE SYMMETRICAL ABOUT CENTER LINES SHOWN.
5. LAMINATE CONTROL DRAWING SPECIFIED BY PART NUMBER.

Figure 4: M45 Package Outline - 10 Pin 3 mm x 3 mm x 1 mm Surface Mount Module

TOP BRAND

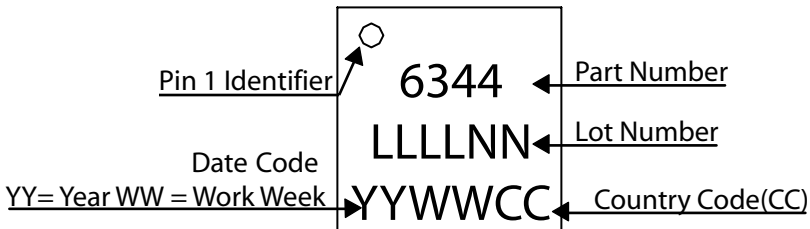
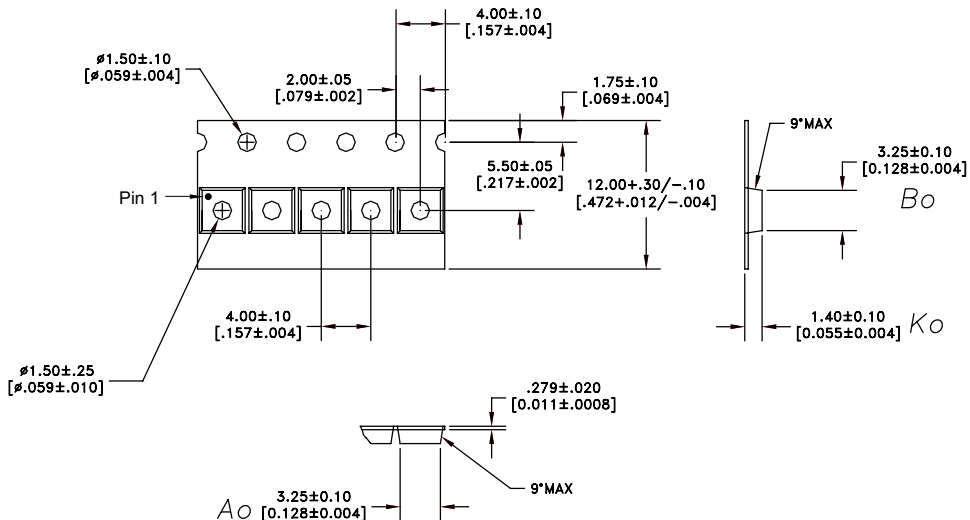

Figure 5: Branding Specification - M45 Package

COMPONENT PACKAGING



NOTES:

- 1. MATERIAL: 3000 (CARBON FILLED POLYCARBONATE)
100% RECYCLABLE.

DIMENSIONS ARE IN MILLIMETERS [INCHES]

DIMENSIONING AND TOLERANCING PER ASME Y14.5M-1994

Figure 6: Tape & Reel Packaging

Table 6: Tape & Reel Dimensions

PACKAGE TYPE	TAPE WIDTH	POCKET PITCH	REEL CAPACITY	MAX REEL DIA
3 mm x 3 mm x 1 mm	12 mm	4 mm	2500	7"

ORDERING INFORMATION

ORDER NUMBER	TEMPERATURE RANGE	PACKAGE DESCRIPTION	COMPONENT PACKAGING
AWC6344Q7	-30 °C to +90 °C	RoHS Compliant 10 Pin 3 mm x 3 mm x 1 mm Surface Mount Module	Tape and Reel, 2500 pieces per Reel
AWC6344P9	-30 °C to +90 °C	RoHS Compliant 10 Pin 3 mm x 3 mm x 1 mm Surface Mount Module	Partial Tape and Reel



ANADIGICS, Inc.
 141 Mount Bethel Road
 Warren, New Jersey 07059, U.S.A.
 Tel: +1 (908) 668-5000
 Fax: +1 (908) 668-5132

URL: <http://www.anadigics.com>

IMPORTANT NOTICE

ANADIGICS, Inc. reserves the right to make changes to its products or to discontinue any product at any time without notice. The product specifications contained in Advanced Product Information sheets and Preliminary Data Sheets are subject to change prior to a product's formal introduction. Information in Data Sheets have been carefully checked and are assumed to be reliable; however, ANADIGICS assumes no responsibilities for inaccuracies. ANADIGICS strongly urges customers to verify that the information they are using is current before placing orders.

WARNING

ANADIGICS products are not intended for use in life support appliances, devices or systems. Use of an ANADIGICS product in any such application without written consent is prohibited.