

NOTES: UNLESS OTHERWISE SPECIFIED
 1. FOR USE WITH RG-8, 8A, 11, 11A AND 213/U CABLE.

2. FOR CABLING INSTRUCTION, SEE CP-480.

3. FOR CABLE CRIMPING, USE DIE KTH-2003.

4. FOR CABLE TRIMMING, USE KTJ-137 AND KTD-138.

5. INTERFACE PER MIL-STD-348, FIG. 304-1.

6. MATERIALS:
 INSULATOR: TEFLON PER ASTM D-4894
 GASKET: SILICON RUBBER PER ZZ-R-765
 OUTER CONTACT AND C-RING: PHOS. BRONZE PER ASTM B-103
 ALL OTHER METAL PARTS; BRASS PER ASTM B-16

7. FINISHES:
 CENTER CONTACT: GOLD PER ASTM B488
 ALL OTHER METAL PARTS: SILVER PER ASTM B-700

8. CONTACT AND FERRULE SUPPLIED UNASSEMBLED.

REV	DESCRIPTION	BY DATE	APPD
K	REDRAWN ER18193	RSM 08/27/09	DCdm

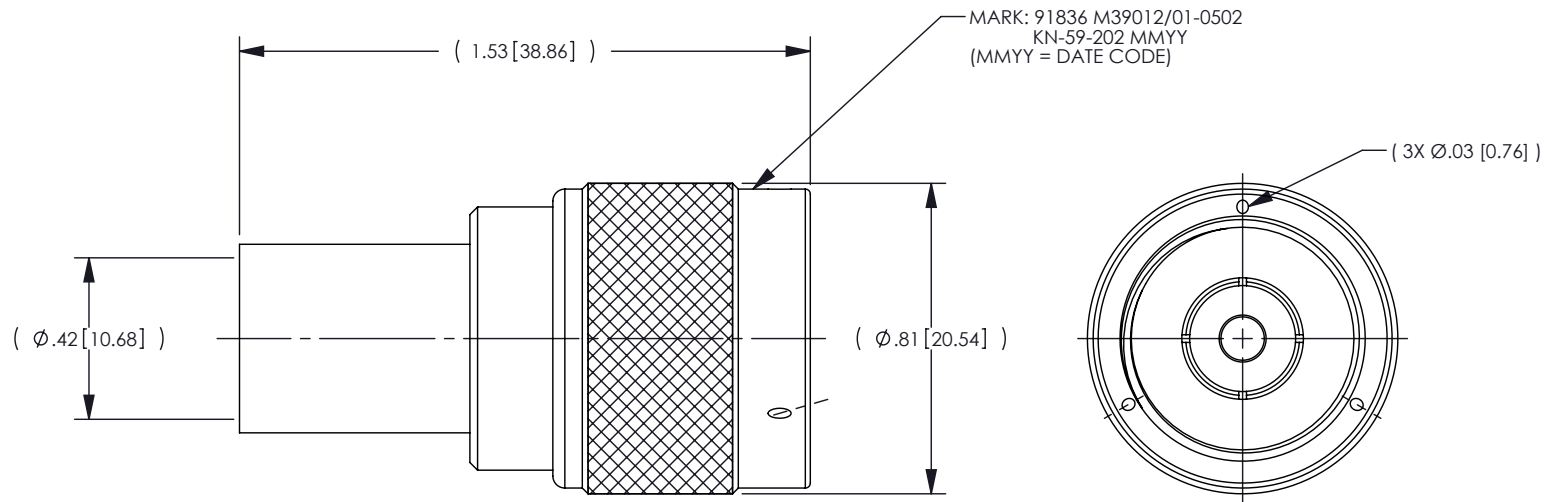

CATALOG P/N: KN-59-202

PER ASME Y14.5M-1994 UNLESS OTHERWISE SPECIFIED: DIMENSIONS ARE IN INCHES [MM] TOLERANCES: DECIMAL: .XX [X.X] ± .01 [0.3] .XXX [X.XX] ± .005 [0.13] .XXXX [X.XXX] ± .0005 [0.025] ANGLES: ± 2° SCALE: 2:1				 by WINCHESTER <small>ELECTRONICS</small> Winchester Electronics Corporation 62 Barnes Industrial Road North Wallingford, Connecticut 06492	
CUSTOMER SALES DRAWING			THIRD ANGLE 		
DRAWN	DATE	APPROVED	DATE	N PLUG	
JL	05/17/74	LI	05/24/74	M39012/01-0502	
APPROVED	DATE	APPROVED	DATE	A	SDKN-59-202
XXX	XX/XX/XX	XXX	XX/XX/XX		
				SHT	OF
				1	1
				REV	K