

POWER MANAGEMENT

Features

- Input Voltage — 4.75V to 45V
- Output Voltage — Up to 65V
- Step-up (Boost) Controller
 - Ultra-Fast Transient Response
 - Programmable Switching Frequency
 - External Sync Frequency for Boost Controller
- Linear Current Sinks
 - 4 Strings, up to 150mA/String
 - Current Matching $\pm 1\%$
 - Current Accuracy $\pm 2\%$
- PWM Dimming
 - String-by-String Phase Shifting
 - Dimming Frequency 100Hz-30kHz
 - User Selectable 9 or 10 Bits Dimming Resolution
 - Optional Synchronization to VSYNC/HSYNC Signal
- External Frequency Synchronization, FSYNC
- 8-bit Analog Dimming
- I²C Interface
 - Fault Status — Open/Short LED, OTP
 - Device Control: SYNC Freq, PLL Setting
- Protection Features
 - Open/Shorted LED(s) and adjustable OVP
 - Over-Temperature
- 4mm X 4mm 24 Ld QFN Package

Applications

- Medium-sized LCD Panel
- Automotive Car Navigation/Information Display
- LCD Monitors

Typical Application Circuit

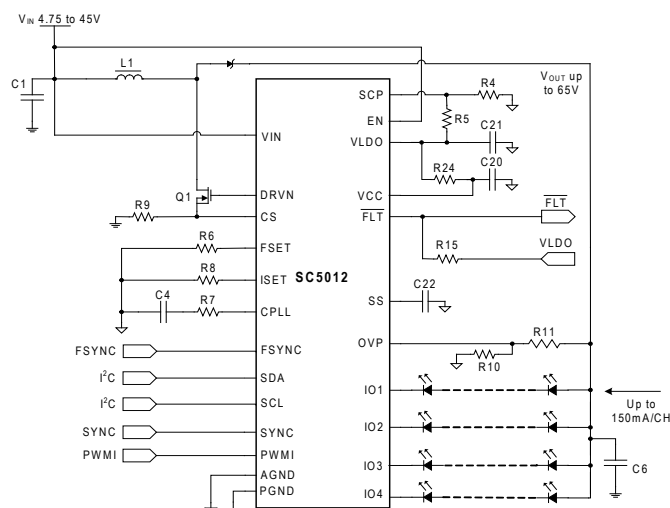

Description

The SC5012 is a 4-channel high-precision, high-efficiency step-up (Boost) HB LED driver designed for backlight applications. It features wide input voltage range (4.75V to 45V), flexible output configuration, wide analog and PWM dimming range, phase shifting, optional fading, external boost controller frequency synchronization (FSYNC), I²C interface, and numerous protection features.

The boost controller, with programmable switching frequency from 200kHz to 2.2MHz, can maximize efficiency by dynamically minimizing the output voltage while maintaining LED string current accuracy. It provides excellent line and load response with no external compensation components. Each linear current sink is matched within $\pm 1\%$ for superb lighting uniformity, and the accuracy of each string current is $\pm 2\%$. An external resistor adjusts the current from 40-150mA per string. It also features PWM dimming resolution of 9 or 10 bits (user selectable) over a dimming frequency from 100Hz to 20kHz, synchronized to the SYNC signal or the boost oscillator. String-by-string phase shifting reduces the demand on the input/output capacitance, decreases EMI, and improves dimming linearity.

SC5012 is available in 4mm X 4mm 24 Ld QFN package.