

2

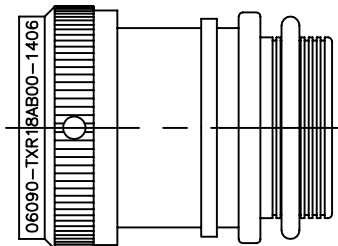

1

THIS DRAWING AND THE INFORMATION SET FORTH HERE-ON ARE THE PROPERTY OF TYCO ELECTRONICS AND ARE TO BE HELD IN TRUST AND CONFIDENCE. PUBLICATION, DUPLICATION, DISCLOSURE, OR USE FOR ANY PURPOSE NOT EXPRESSLY AUTHORIZED IN WRITING BY TYCO ELECTRONICS IS PROHIBITED.	REVISIONS			
	LTR	DESCRIPTION	DATE	APPROVED
	G	REVISED PER ECO-13-003640	03/1/2013	-



CODE 18  
STRAIGHT ADAPTER

NOTES:

1. THIS PRODUCT IS DESIGNED TO TERMINATE A BRAIDED CABLE SHIELD AND A HEAT SHRINKABLE LIPPED BOOT TO A CONNECTOR.
2. SEE CH00-0250-008 FOR ORDERING INFORMATION, MODIFICATIONS AND ADDITIONAL DIMENSIONS.
3. SEE DRAWING "TR" FOR DETAIL ON TINEL-LOCK RING. RINGS ARE DESIGNED TO BE HEATED ELECTRICALLY. ALL RINGS ARE MARKED WITH THERMOCHROMIC PAINT WHICH CHANGES COLOR WHEN INSTALLATION TEMPERATURE IS REACHED.
4. ADAPTER TO BE PERMANENTLY MARKED WITH CODE IDENT. NO. AND PART NO. LESS RING DESIGNATOR (E.G.: 06090-TXR18AB00-1406). RINGS SHALL BEAR NO MARKING.
5. FOR LARGER ENTRY SIZES, A 2 PIECE ADAPTER (TYPE II) IS SUPPLIED.
6. ADAPTER MATES TO MIL-C-5015D, CLASS A, E & R, MS3100, MS3101 & MS3106. RESILIENT INSERT, SOLDER TYPE & BENDIX 10-214, CANNON CA-RX COMMERCIAL CRIMP TYPE.
7. ADDITIONAL PIECE(S) SUPPLIED WHEN CONNECTOR MANUFACTURER IS UNKNOWN ("D" IN TABLE III) AND ENTRY SIZE DOES NOT EXCEED VALUE IN TABLE I. SEE FIGURE A PAGE 2 OF 4.
8. ALL THREAD SIZES FOR ORDER NO. APPLY.
9. ANTI-ROTATIONAL SET SCREW, 3 THREADED HOLES 120°±5° APART, SINGLE MATING SET SCREW SUPPLIED: AN565DC4H2. NOT REQUIRED FOR TYPE II ADAPTERS.

If this document is printed it becomes uncontrolled. Check for the latest revision

Raychem Adapters  
CUSTOMER DRAWING

©2005-2013 Tyco Electronics Corporation All rights reserved.

UNLESS OTHERWISE SPECIFIED DIMENSIONS ARE IN INCHES. .XXX ± 0.005 .XX ± 0.01 .X ± 0.1 ANGLES .X ± 0.5 DEG	DRAWN	R. RAMIREZ	04-19-93		TE Connectivity			
	CHECKED	---	---		TITLE			
	MATERIAL	---	---	---	TINEL-LOCK ADAPTER			
FINISH	---	---	---	SIZE	CODE IDENT. NO.	DWG. NO.	REV	
	CAD NAME:	TXR18_CD		A	06090	TXR18	G	
	RPN:	---		DO NOT SCALE THIS DRAWING			SHEET 1 OF 4	

2



1

If this document is printed it becomes uncontrolled. Check for the latest revision

SEE SHEET 1 FOR REVISIONS

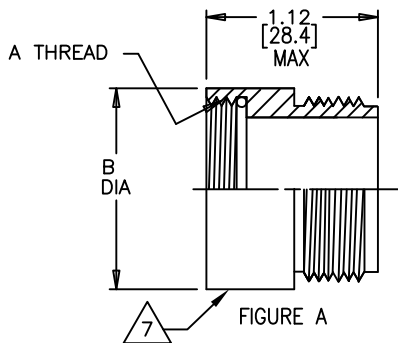
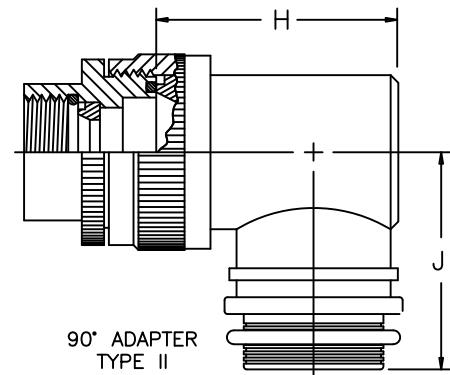
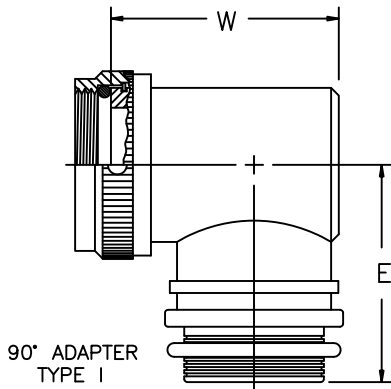
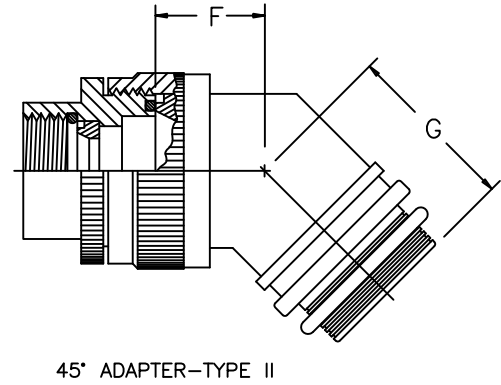
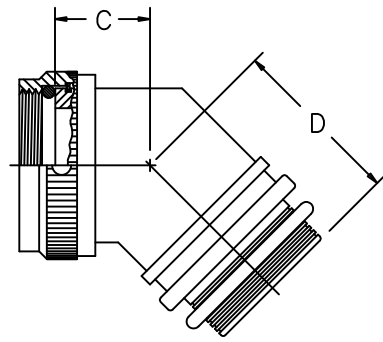
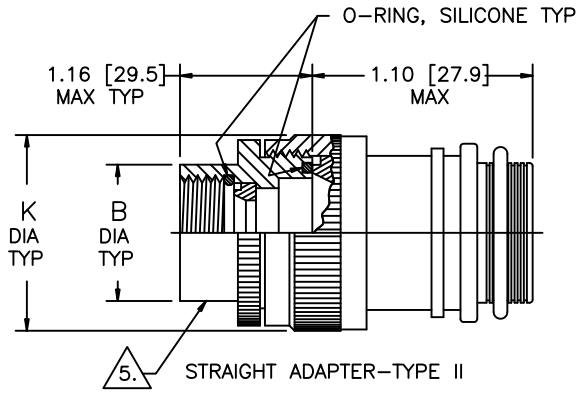
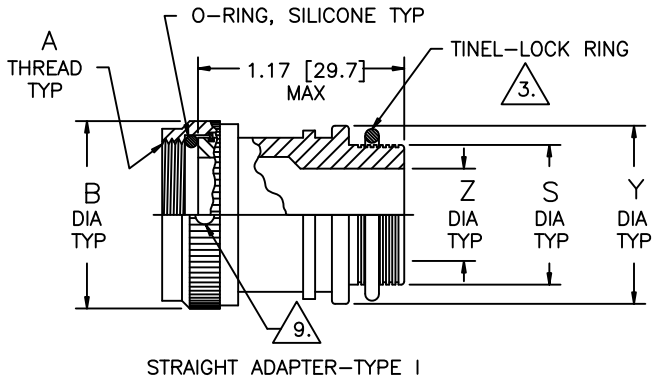

# Raychem Adapters CUSTOMER DRAWING

SIZE A	CODE IDENT. NO. 06090	DWG. NO. TXR18	REV G
DO NOT SCALE THIS DRAWING		CAD NAME:TXR18_CD	SHEET 2 OF 4

SEE SHEET 1 FOR REVISIONS

TABLE I

ORDER NO.	SHELL SIZE △	MFR CODE TABLE III	MAX ENTRY SIZE TYPE I △	A THREAD CLASS 2B	B DIA MAX	C MAX	D MAX	E MAX	W MAX
08	8S	B	04	.375-32 UNEF	.73 [18.5]	.80 [20.3]	.92 [23.4]	1.23 [31.2]	.931 [23.6]
		C		.438-28 UNEF					.994 [25.2]
		A,R		.438-27 UNS					
		D △		△					
10	10S	—	06	.500-28 UNEF	.79 [20.1]	.83 [21.1]	.95 [24.1]	1.23 [31.2]	1.06 [26.8]
11	10SL	C	07	.562-24 UNEF	.85 [21.6]	.83 [21.1]	.95 [24.1]	1.23 [31.2]	1.12 [28.4]
		A,B,R		.625-24 UNEF	.92 [23.4]				1.18 [30.0]
		D △		△	.92 [23.4]				1.12 [28.4]
12	12 & 12S	B,C	08	.625-24 UNEF	.92 [23.4]	.83 [21.1]	.95 [24.1]	1.23 [31.2]	1.18 [30.0]
		A,R		.688-24 UNEF	.98 [24.9]	.86 [21.8]	.98 [24.9]	1.30 [33.0]	1.24 [31.6]
		D △		△	.98 [24.9]	.86 [21.8]	.98 [24.9]	1.30 [33.0]	1.18 [30.0]
14	14 & 14S	—	10	.750-20 UNEF	1.04 [26.4]	.86 [21.8]	.98 [24.9]	1.30 [33.0]	1.31 [33.2]
16	16 & 16S	—	12	.875-20 UNEF	1.23 [31.2]	.89 [22.6]	1.02 [25.9]	1.42 [36.1]	1.43 [36.3]
18	18	—	12	1.000-20 UNEF	1.35 [34.3]	.92 [23.4]	1.05 [26.7]	1.48 [37.6]	1.49 [37.9]
20	20	A,B,C	16	1.125-18 UNEF	1.48 [37.6]	.95 [24.1]	1.08 [27.4]	1.55 [39.4]	1.68 [42.7]
		R		1.125-24 UNS					
		D △		△					
22	22	—	18	1.250-18 UNEF	1.60 [40.6]	.98 [24.9]	1.11 [28.2]	1.61 [40.9]	1.81 [45.9]
24	24	—	20	1.375-18 UNEF	1.73 [43.9]	.98 [24.9]	1.11 [28.2]	1.67 [42.4]	1.93 [49.0]
28	28	—	22	1.625-18 UNEF	2.10 [53.3]	1.08 [27.4]	1.17 [29.7]	1.86 [47.2]	2.06 [52.2]
32	32	B,C	24	1.875-16 UN	2.23 [56.6]	1.11 [28.2]	1.23 [31.2]	1.92 [48.8]	2.31 [58.6]
		A,R		1.906-18 UN					
		D △		△					
36	36	B	24	2.062-16 UNS	2.48 [63.0]	1.23 [31.2]	1.27 [32.3]	2.05 [52.1]	2.56 [64.9]
		R		2.062-20 UNS					
		C		2.125-16 UN					
		A		2.125-18 UNS					
		D △		△					
40	40	B	24	2.312-16 UNS	2.73 [69.3]	1.27 [32.3]	1.30 [33.0]	2.17 [55.1]	2.81 [71.3]
		A,C,R		2.375-16 UN					
		D △		△					
44	44	—	24	2.625-16 UN	3.23 [82.0]	1.34 [34.0]	1.36 [34.5]	2.42 [61.5]	3.06 [77.6]
48	48	C	24	2.812-18 UNS	3.23 [82.0]	1.34 [34.0]	1.36 [34.5]	2.42 [61.5]	3.31 [84.0]
		A,R		2.875-16 UN					
		D △		△					

If this document is printed it becomes uncontrolled. Check for the latest revision

Raychem Adapters  
CUSTOMER DRAWING

SIZE A	CODE IDENT. NO. 06090	DWG. NO. TXR18	REV G
DO NOT SCALE THIS DRAWING		CAD NAME:TXR18_CD	SHEET 3 OF 4

TABLE II

ENTRY SIZE	Z +.010 -.020	S DIA	Y ±.015 [±0.38]	F MAX	G MAX	J MAX	H MAX	K MAX
04	.250 [6.35]	.376 [ 9.56] .370 [ 9.39]	.550 [13.97]	N/A	N/A	N/A	N/A	N/A
05	.312 [7.92]	.438 [11.13] .432 [10.97]	.612 [15.54]	.77 [19.6]	.93 [23.6]	1.16 [29.5]	1.19 [30.2]	.80 [20.3]
06	.375 [9.52]	.501 [12.73] .495 [12.57]	.675 [17.14]	.77 [19.6]	.93 [23.6]	1.16 [29.5]	1.19 [30.2]	.80 [20.3]
07	.437 [11.09]	.563 [14.31] .556 [14.12]	.737 [18.71]	.80 [20.3]	.95 [24.1]	1.22 [31.0]	1.38 [35.1]	.92 [23.4]
08	.500 [12.70]	.626 [15.91] .619 [15.72]	.800 [20.32]	.80 [20.3]	.95 [24.1]	1.22 [31.0]	1.38 [35.1]	.92 [23.4]
10	.625 [15.87]	.752 [19.11] .742 [18.84]	.925 [23.49]	.84 [21.3]	1.00 [25.4]	1.35 [34.3]	1.51 [38.4]	1.18 [30.0]
12	.750 [19.05]	.877 [22.28] .867 [22.02]	1.050 [26.67]	.86 [21.8]	1.01 [25.7]	1.40 [35.6]	1.63 [41.4]	1.35 [34.3]
14	.875 [22.23]	1.002 [25.46] .991 [25.17]	1.175 [29.84]	.88 [22.4]	1.04 [26.4]	1.46 [37.1]	1.78 [45.2]	1.41 [35.8]
16	1.000 [25.40]	1.127 [28.63] 1.116 [28.34]	1.300 [33.02]	.91 [23.1]	1.06 [26.9]	1.53 [38.9]	1.88 [47.8]	1.60 [40.6]
18	1.125 [28.57]	1.252 [31.81] 1.241 [31.52]	1.425 [36.19]	.93 [23.6]	1.09 [27.7]	1.59 [40.4]	2.01 [51.1]	1.66 [42.2]
20	1.250 [31.75]	1.377 [34.98] 1.366 [34.69]	1.550 [39.37]	.98 [24.9]	1.13 [28.7]	1.78 [45.2]	2.13 [54.1]	2.04 [51.8]
22	1.375 [34.93]	1.502 [38.15] 1.488 [37.79]	1.675 [42.55]	1.03 [26.2]	1.38 [35.1]	1.85 [47.0]	2.29 [58.2]	2.23 [56.6]
24	1.500 [38.10]	1.627 [41.33] 1.613 [40.97]	1.800 [45.72]	1.08 [27.4]	1.44 [36.6]	1.92 [48.8]	2.42 [61.5]	2.23 [56.6]

TABLE III

MFR CODE	CONNECTOR MANUFACTURER (MS 3100, MS 3101 & MS 3106)
A	AMPHENOL—CLASS A
B	BENDIX—CLASS A, E & R
C	CANNON—CLASS A, E & R
D	MFR UNKNOWN, CLASS A, E & R
R	AMPHENOL—CLASS R
—	MFR CODE NOT REQUIRED

## Raychem Adapters CUSTOMER DRAWING

If this document is printed it becomes uncontrolled. Check for the latest revision

SIZE	CODE IDENT. NO.	DWG. NO.	REV
A	06090	TXR18	G
DO NOT SCALE THIS DRAWING		CAD NAME:TXR18_CD	SHEET 4 OF 4