

GENERAL DESCRIPTION

The EM34004 is a single-chip LSI CMOS calculator with 12-digits 2-memory or 10-digits 2-memory. EM34004 can drive the liquid crystal display (LCD) with single power supply. Single power supply operation, wide operating voltage and lower power consumption make it suitable for 1.5V solar battery operated calculator. Beside EM34004 can be selected as Auto Power OFF or Manual Power OFF with Lock Key. It also can be selected as Memory Hold or Clear at Power OFF.

FEATURES

- Display : 12-digit or 10-digit (selectable with a pin-programmable) of data, 1-digits of sign, error, memory load symbol.
- Algebraic mode
- Standard 4 function (addition, subtraction, multiplication, division).
- Memory and Grand total calculation.
- Accumulating GT memory register with count up(down) item counter.
- Automatic percentage operation with add-on discount.
- Automatic delta percentage, mark-up and mark-down operations.
- Square root.
- Constant calculation.
- Chain calculation.
- Change sign.
- Floating point (selectable with a switch).
- Fixed point ("0", "1", "2", "3", "4", or "6" selectable with a switch).
- Adding point mode(selectable with a switch).
- Rounding switch(rounding up, down and off).
- Trailing zero suppression.
- Punctuation on display, commas for thousands.
- Memory and GT memory contents indicator, turned with nonzero in the memory and GT memory.
- Registration overflow, indicating too many digits are entered (the most significant digit are protected).
- Result overflow, indicating during calculation (most function key are locked as it happened).
- Memory overflow indicating.
- Complementary output buffer for direct driving of liquid crystal display.
- Oscillator/clock generator internal to chip.
- Keyboard encoding internal to chip.
- Automatic power on clear.
- Wide supply voltage range (1.1 to 1.8V)
- Very low power consumption.

PIN DESCRIPTIONS

Symbol	I/O	Function
COM1	O	Common 1 to LCD
COM2	O	Common 2 to LCD
COM3	O	Common 3 to LCD
A1	O	O/P Signal to LCD and O/P strobe to lock key
B1	O	O/P Signal to LCD and O/P strobe to lock key
C1	O	O/P Signal to LCD and O/P strobe to lock key
A2	O	O/P Signal to LCD and O/P strobe to lock key
B2	O	O/P Signal to LCD and O/P strobe to lock key
C2	O	O/P Signal to LCD and O/P strobe to lock key
A3	O	O/P Signal to LCD and O/P strobe to lock key
B3	O	O/P Signal to LCD and O/P strobe to lock key
C3	O	O/P Signal to LCD and O/P strobe to lock key
A4	O	O/P Signal to LCD and O/P strobe to lock key
B4	O	O/P Signal to LCD
C4	O	O/P Signal to LCD
A5	O	O/P Signal to LCD
B5	O	O/P Signal to LCD
C5	O	O/P Signal to LCD
A6	O	O/P Signal to LCD
B6	O	O/P Signal to LCD
C6	O	O/P Signal to LCD
A7	O	O/P Signal to LCD
B7	O	O/P Signal to LCD
C7	O	O/P Signal to LCD
A8	O	O/P Signal to LCD
B8	O	O/P Signal to LCD
C8	O	O/P Signal to LCD
A9	O	O/P Signal to LCD
B9	O	O/P Signal to LCD
C9	O	O/P Signal to LCD
A10	O	O/P Signal to LCD
B10	O	O/P Signal to LCD
C10	O	O/P Signal to LCD
A11	O	O/P Signal to LCD
B11	O	O/P Signal to LCD
C11	O	O/P Signal to LCD
A12	O	O/P Signal to LCD
B12	O	O/P Signal to LCD

* This specification are subject to be changed without notice.

Symbol	I/O	Function
C12	O	O/P Signal to LCD
S1	O	O/P Signal to LCD
S2	O	O/P Signal to LCD
GND		Ground
VA		Connected as voltage doubler
VB		Connected as voltage doubler
V _{EE}		Connected to capacitor
V _{DD}		Power supply
TS1		Test pin
RESET	I	System reset
K1	O	O/P strobe signal to key
K2	O	O/P strobe signal to key
K3	I/O	O/P strobe signal and key I/P signal
K4	I/O	O/P strobe signal and key I/P signal
K5	I/O	O/P strobe signal and key I/P signal
K6	I/O	O/P strobe signal and key I/P signal
K7	I/O	O/P strobe signal and key I/P signal
K8	I/O	O/P strobe signal and key I/P signal
K9	I	Key I/P signal
K10	I	Key I/P signal
K11	I	Key I/P signal
K12	I	Key I/P signal
K13	I	Key I/P signal
K14	I	Key I/P signal

FUNCTION DESCRIPTIONS

A). Operation Characteristics

a). Constant Operation

The EM34004 has implied constant mode on +, -, X, ÷ & % operations. The constant is performed automatically by the "=" key, "%" key, or "% " key without a constant for addition, subtraction and division while the first operand is the constant for multiplication.

b). Number Entry

Numericals can be entered up to 12-digit.

c). Memory Protection

In any error detection, the memory contents present before the error detection are protected.

d). Memory Indication

If the memory contents are a number other than zero, "M" is indicated in the sign-digit position.

e). Auto Power Off

If no key is depressed for a specific period of time, the power supply will automatically turn off (pin option). This time interval up to power-off is 600 sec.

f). Key Definition

i). Touch Key Constitution

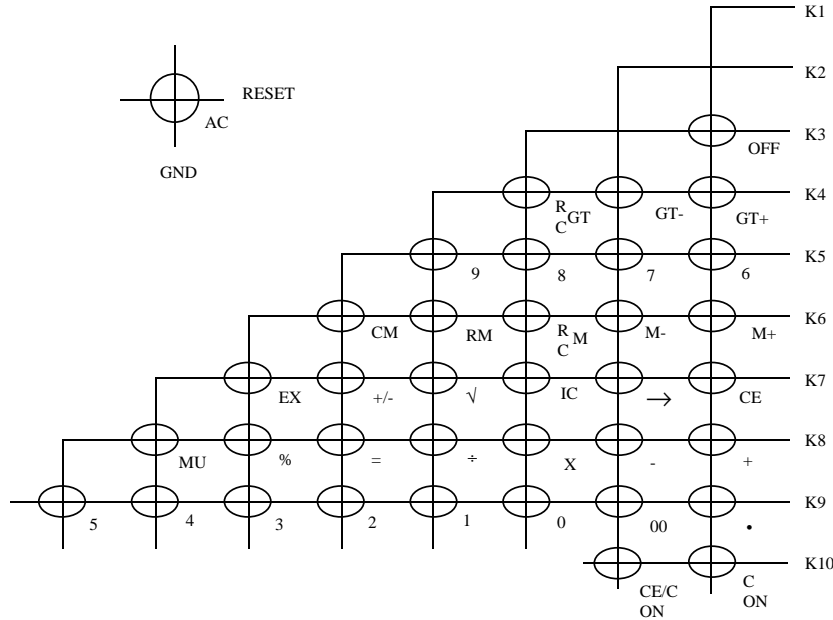

ii). Lock Key Constitution

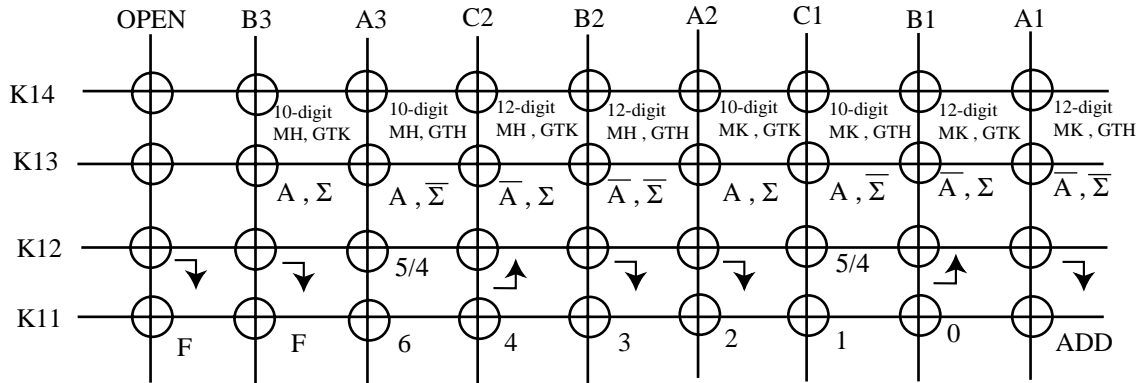

- K14 : Select with Calculated Digits and Memory Hold Status, MH (Memory Hold), MK (Memory Kill), GTH (GT Memory Hold) and GTX (GT Memory Kill) at Auto Power OFF or OFF key.
- K13 : Select with Auto Power OFF mode and Total switch.
- K12 : Rounding switches.
- K11 : Select with Fixed point or Floating mode.

B). Keyboard Description

a). Equal Key (=)

- i). Performs Keyed-in operation and maintains that operation for possible use.
- ii). Establishes power/reciprocation calculation.

b). Multiplication Key (X)

- i). Enters multiplicand.
- ii). Performs previous operation and displays result.

c). Division Key (\div)

- i). Enters dividend.
- ii). Performs previous operation and displays result.

d). Addition Key (+)

- i). Conditions machine for an addition.
- ii). Performs previous operation and displays result.

e). Subtraction Key (-)

- i). Conditions machine for a subtraction.
- ii). Performs previous operation and displays result.

f). Percent Key (%)

The purpose of the percent key is to allow for calculation of add-on and discount. Determination of add-on requires the principal amount to be the first entry followed by the "+" or "X" key, with the percentage being the second entry. Depression of the percent key yields the amount to add on, such as tax or interest. Depression of the "=" key adds this amount to the principal.

g). Change Sign Key (+/-)

Pushing the "+/-" key twice in succession causes the corresponding sign to appear and disappear. During digit entry, this function changes the sign of the entered factor.

h). Power On/All Clear Key (ON/AC)

- i). First push power-on displays "0".
- ii). In the middle of a digit entry, a second push will clear all operating register).

i). Clear Entry/Clear Key (CE/C)

- i). During the digit entry, the first depression will clear the entry register. And display the previous enter number again.
- ii). The second push will clear all registers.

j). Clear Entry Key (CE)

During the digit entry will clear the entry register and display number "0".

k). Square Root Key ($\sqrt{\quad}$)

Extracts the square root of a positive number displayed in the entry register.

l). Memory Plus Key (M+)

- i). Adds the current display to the contents of memory.
- ii). It will terminate a number entry.

- m). Memory Minus Key (M-)
 - i). Subtracts the current display from the contents of memory
 - ii). It will terminate a number entry.
- n). memory Recall and Clear Key (RCM)
 - i). First push, as RM key, transfers the contents of the memory register into the display register.
 - ii). Second push, as CM key, clears the memory.
- o). Number, Decimal Key ("00", "0 - 9", "•")

The first number key in a sequence will clear the display and enter the digit in the display. Successive entries will shift the display left and enters the data in display register. The first decimal point entered is effective. An attempted entry of more than 12 digits or 11 decimal places will be ignored.
- p). GT Memory Recall and Clear Key (RC GT)
 - i). First push, as RGT key, transfers the contents of the GT memory register into the display register.
 - ii). Second push, as CGT key, clears the GT memory.
- q). Exchange Key (EX)

Exchange two operand between the operator. For example, key in "a-b", and then key in "EX" will exchange a and b to "b-a".
- r). Shift Key (→)

Delete the rightest digit and others will shift to right.
- s). Item Counter Key (IC)
 - i). The "+" and "=" key will increase the counter's contents by one.
 - ii). The "-" will decrease it by two.
 - iii). The others operator key and number key will not change it.
- t). Grand Total Plus (GT+)

Ands the current display to the content of grand total memory.
- u). Grand Total Minus (GT-)

Subtracts the current display from the content of grand total memory.
GT- will terminate a number entry.

C). Error Conditions

a). Error Detection

System errors occur when :

- i). The integral part of any calculation result exceeds 12 digits.
- ii). The integral part of any memory calculation result exceeds 12-digit or when the integral part of any addend or subtrahend to memory exceeds 12-digit.
- iii). The integral part of a mark-up and mark-down calculation result exceeds 12-digit.
- v). A division by zero is attempted.
- iv). An extraction of the square root of a negative number is attempted.

b). Error Indication

i). System error :

a). "0" is indicated in the first-digit position and "E" in the sign-digit position.

b). The high-order 12-digit of a calculation result is indicated together with "E". The location of the decimal point corresponds to the result of calculation times $1e-12$, and no zero shift is performed.

c). Error Release

i). System error :

A system error can be released by depressing ON/AC key or CE/C key. However the calculation result is not cleared by CE/C key but is retained.

D). LCD Display

a). Inter Connection of LCD

i). Select of 10-digits

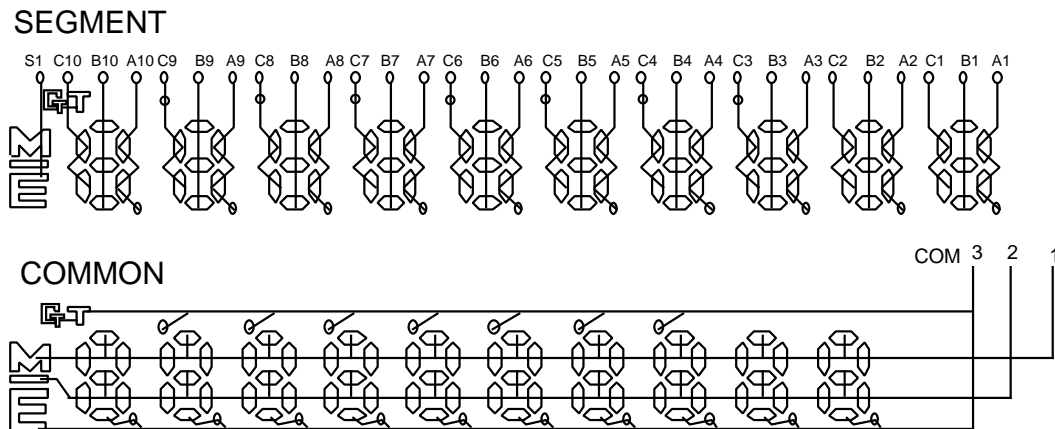

ii). Select of 12-digits

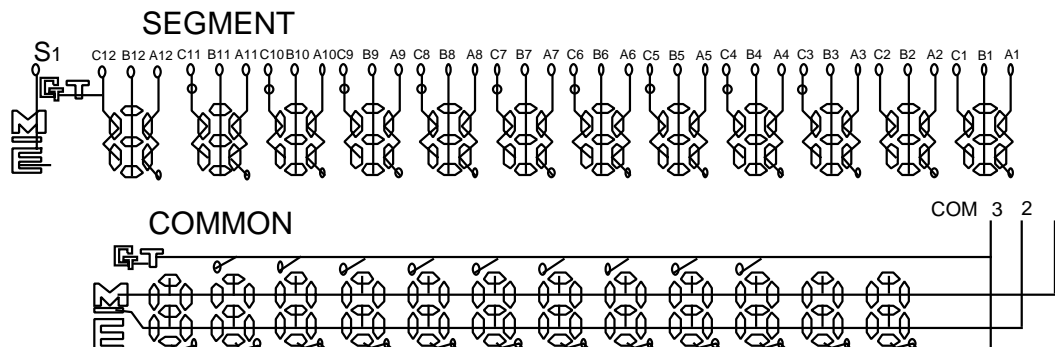

E). Waveforms for Display

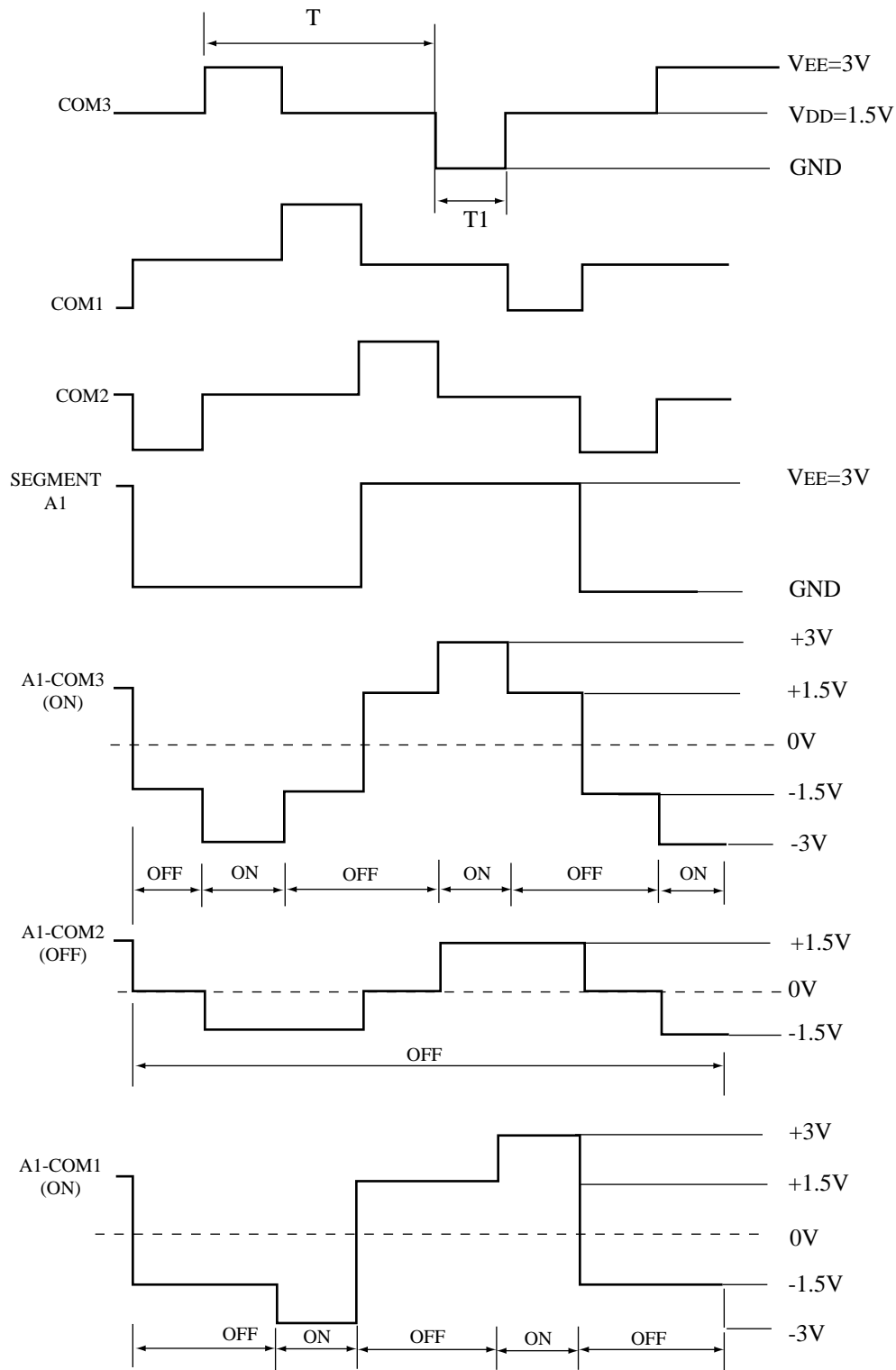

When $f_0 = 18 \text{ KHz}$

$T = 1/93.8 \text{ Hz}$ $T1 = 3.56 \text{ ms}$

ABSOLUTE MAXIMUM RATINGS

Items	Sym.	Min.	Max.	Unit
Supply Voltage	$V_{DD} - V_{SS}$	-0.3	2.0	V
Input Voltage	V_{in}	-0.3	$V_{DD} + 0.3$	V
Operating Temperature	Top	0	50	°C
Storage Temperature	Tstg	-55	+125	°C

ELECTRICAL CHARACTERISTICS

($V_{DD} = 1.5V \pm 0.2V$, GND=0V, $T_A = 25^\circ C$, $V_{EE} = 3.0 \pm 0.4V$)

Parameter	Name	Sym.	Min.	Typ.	Max.	Unit	Condition
Operating Voltage	-	V_{DD}	1.1	1.5	1.8	V	
"1" Input Voltage	K3~K10 RESET	$V_{IH}(1)$	$V_{DD} - 0.4$	-	V_{DD}	V	
"1" Input Voltage	K11~K14	$V_{IH}(2)$	$V_{EE} - 0.4$	-	V_{EE}	V	
"0" Input Voltage	K3~K14 RESET	V_{IL}	0	-	0.4	V	
"1" Output Voltage	SEGMENT COM1~3	$V_{OH}(1)$	$V_{EE} - 0.2$	-	V_{EE}	V	
"0" Output Voltage	SEGMENT COM1~3	$V_{OL}(1)$	0	-	0.2	V	
"M" Output Voltage	COM1~3	V_{OM}	$V_{DD} - 0.2$	-	$V_{DD} + 0.2$	V	
"1" Output Voltage	K1~K10	$V_{OH}(2)$	$V_{DD} - 0.2$	-	V_{DD}	V	
"0" Output Voltage	K1~K14	$V_{OL}(2)$	0	-	0.2	V	
"1" Output Resistance	SEGMENT COM1~3	R_{OH}	-	-	70	K Ω	$V_{OUT} = V_{EE} - 0.5V$
"0" Output Resistance	SEGMENT COM1~3	R_{OL}	-	-	70	K Ω	$V_{OUT} = 0.5V$
Key Pull Down Resistance	K1~K10	$R_{KEYL}(1)$	240	-	650	K Ω	$V_{OUT} = V_{DD}$
Key Pull Up Resistance	K1~K10 RESET	$R_{KEYH}(1)$ $R_{KEYH}(2)$	- 50	- -	10 370	K Ω K Ω	$V_{OUT} = 0.5V$ $V_{OUT} = 0.5V$
Oscillating (WAIT)		f_{0_WAIT}	10.8	18.0	25.2	KHz	$V_{DD} = 1.5V$
Frequency (OPERATE)		f_{0_OP}	57.6	96.0	134.4	KHz	$V_{DD} = 1.5V$
Frame Frequency	SEGMENT COM1~3	f_F	56.3	93.8	131	Hz	$V_{DD} = 1.5V$
Supply Current	1(WAIT) 2(OPERATE) 3(OFF)	I_{DD_WAIT} I_{DD_OP} I_{DD_OFF}	- - -	2.2 7.0 -	3.4 11.0 1.0	μA μA μA	$V_{DD} = 1.5V$ $V_{DD} = 1.5V$ $V_{DD} = 1.5V$
Power off Timer Times		T	429	600	1001	SEC	$V_{DD} = 1.5V$

ARITHMETIC OPERATIONS

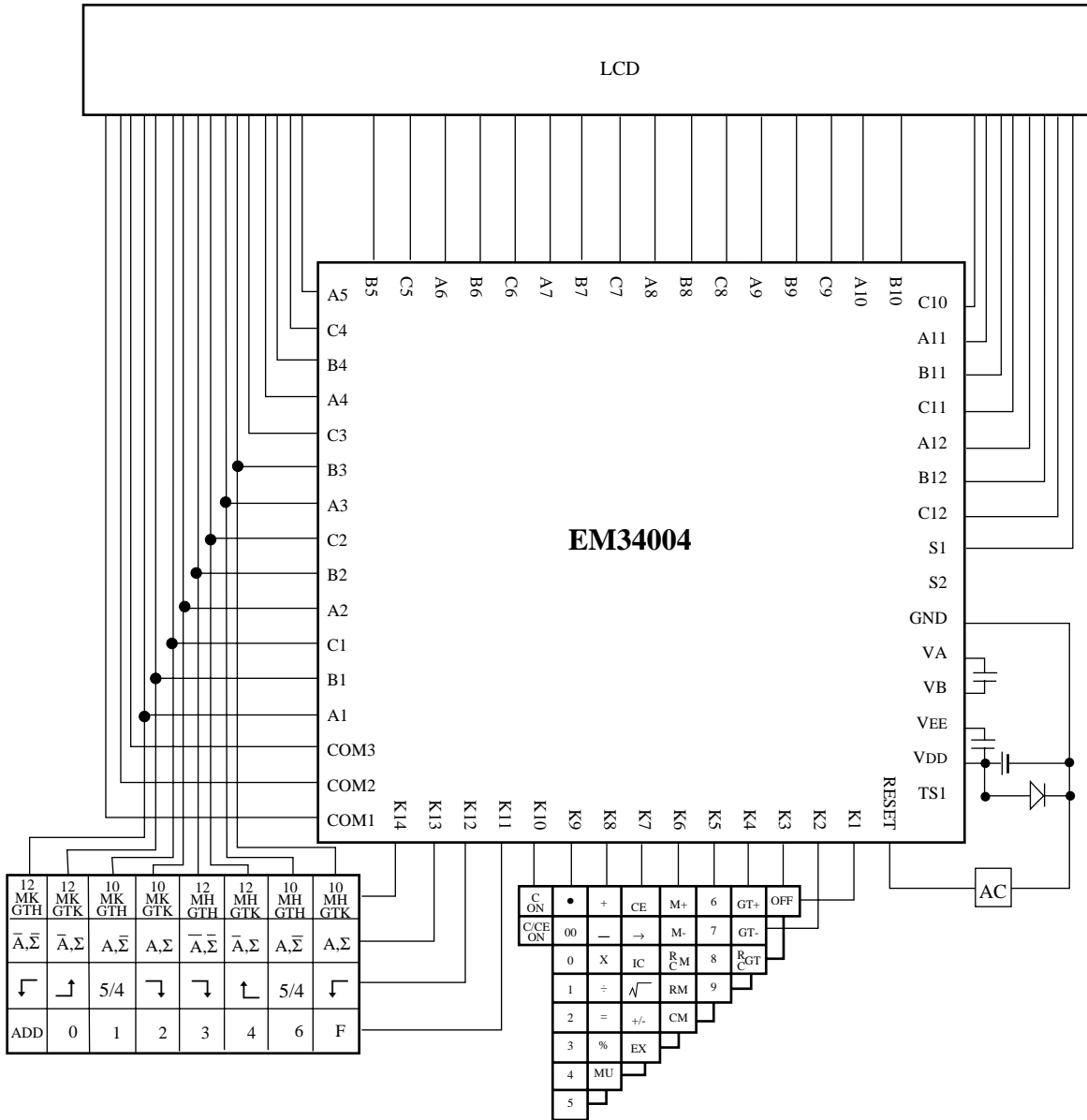

PAD DIAGRAM

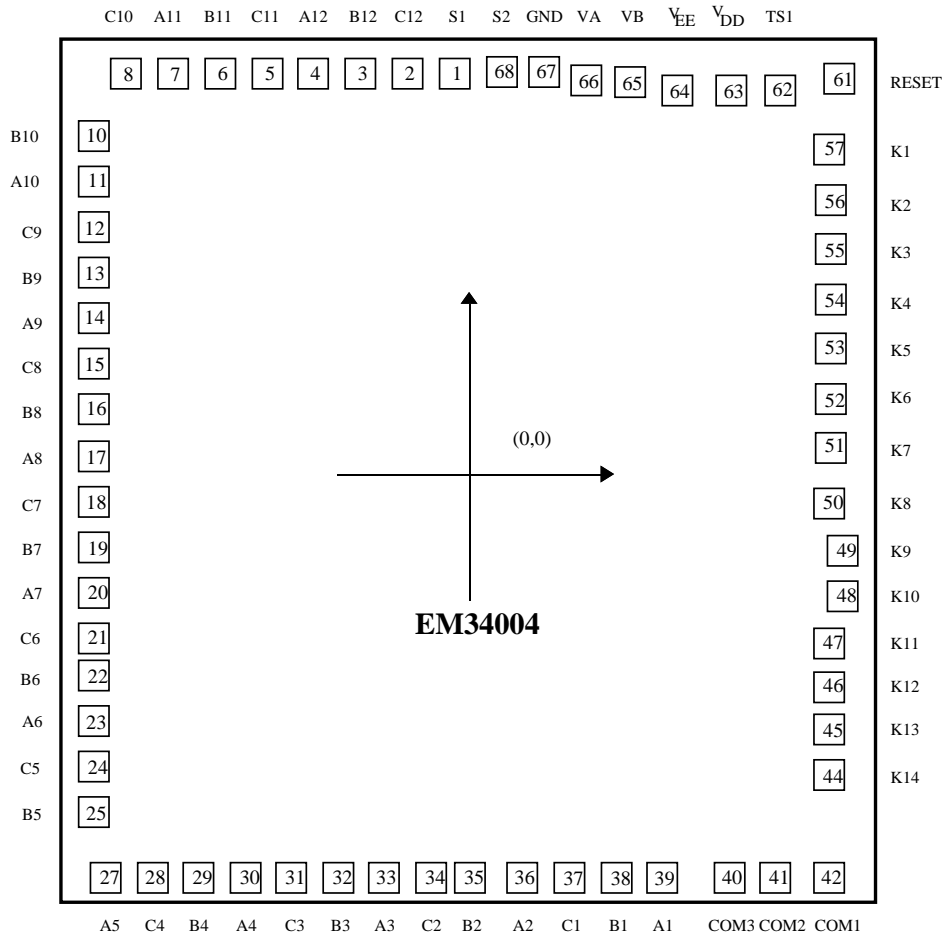

Pad No.	Symbol	X	Y
1	S1	-53.3	1207.0
2	C12	-188.3	1207.0
3	B12	-323.3	1207.0
4	A12	-458.3	1207.0
5	C11	-593.3	1207.0
6	B11	-728.2	1207.0
7	A11	-863.3	1207.0
8	C10	-998.3	1207.0
9			
10	B10	-1096.4	991.4
11	A10	-1096.4	856.4
12	C9	-1096.4	721.4
13	B9	-1096.4	586.4
14	A9	-1096.4	451.4
15	C8	-1096.4	316.4
16	B8	-1096.4	181.4

* This specification are subject to be changed without notice.



Pad No.	Symbol	X	Y
17	A8	-1096.4	46.4
18	C7	-1096.4	-88.6
19	B7	-1096.4	-223.6
20	A7	-1096.4	-358.6
21	C6	-1096.4	-493.6
22	B6	-1096.4	-628.6
23	A6	-1096.4	-763.6
24	C5	-1096.4	-898.6
25	B5	-1096.4	-1033.6
26			
27	A5	-1049.4	-1249.4
28	C4	-914.4	-1249.4
29	B4	-779.4	-1249.4
30	A4	-644.4	-1249.4
31	C3	-509.4	-1249.4
32	B3	-374.4	-1249.4
33	A3	-239.4	-1249.4
34	C2	-104.4	-1249.4
35	B2	30.6	-1249.4
36	A2	165.6	-1249.4
37	C1	300.6	-1249.4
38	B1	435.6	-1249.4
39	A1	570.6	-1249.4
40	COM3	751.3	-1249.4
41	COM2	892.3	-1249.4
42	COM1	1032.7	-1249.4
43			
44	K14	1039.8	-915.5
45	K13	1039.8	-769.0
46	K12	1039.8	-625.8
47	K11	1039.8	-479.3
48	K10	1087.2	-339.1
49	K9	1087.2	-198.6
50	K8	1057.6	-56.3
51	K7	1057.6	86.8
52	K6	1057.6	232.6
53	K5	1057.6	375.7
54	K4	1057.6	521.5
55	K3	1057.6	664.6
56	K2	1057.6	810.4

* This specification are subject to be changed without notice.

Pad No.	Symbol	X	Y
57	K1	1057.6	953.5
58			
59			
60			
61	RESET	1085.2	1201.8
62	TS1	939.3	1172.2
63	VDD	792.6	1170.8
64	VEE	624.9	1164.2
65	VB	489.9	1188.5
66	VA	351.7	1188.5
67	GND	216.7	1207.0
68	S2	81.7	1207.0

Chip Size : 2500x 2800 μm