

DASH NO.	DESCRIPTION	MADE FROM
----------	-------------	-----------

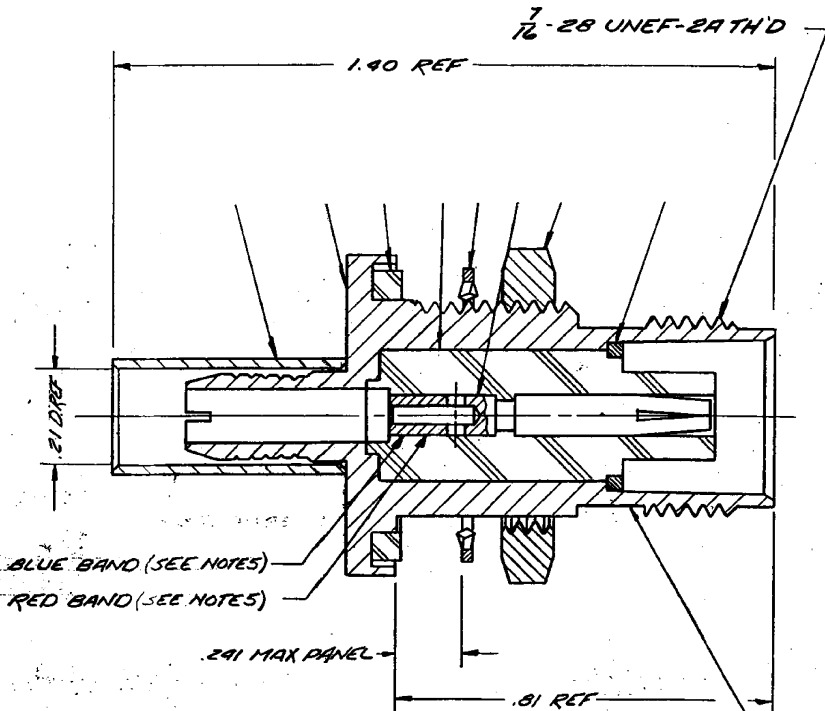

NOTES:

1. FOR USE WITH RG-58, 141 & 303/U CABLE.
2. FOR CABLE TRIMMING USE KTJ-113 & KTD-166.
3. FOR FORMING USE CRIMP DIE SIZE O1.
4. FOR CABLING INSTRUCTIONS SEE CP-465.
5. APPLY TWO BANDS, ONE BLUE & ONE RED, PER EO 25433.

UNLESS OTHERWISE SPECIFIED:

- | | |
|--|--|
| 1. TOLERANCES: FRACTIONS & 2 PLACE DECIMALS ± .010 | 2. REMOVE ALL BURRS, BREAK SHARP EDGES .005 MAX. |
| 3 PLACE DECIMALS ± .004 | 3. NO FILLETS PERMITTED. |
| 7, 1, R. CONCENTRICITY OF ANY 2 DIAMETERS MAY NOT EXCEED HALF THE SUM OF THEIR TOLERANCES. | 4. SURFACE ROUGHNESS 63 MICROINCHES RMS MAX. |
| | 5. ALL DIMENSIONS PRIOR TO PLATING. |

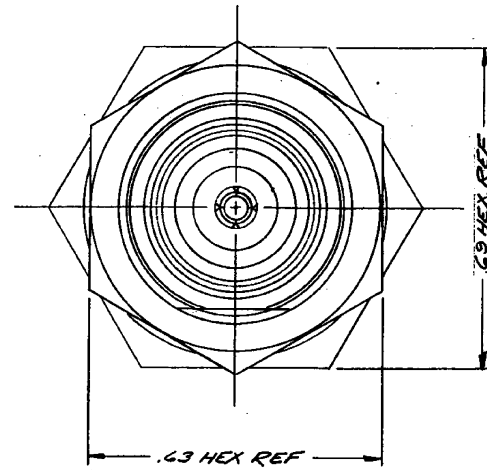
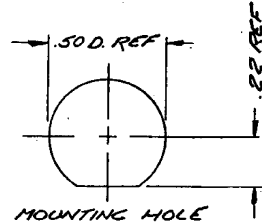

SD

M39012/28-0504

REVISIONS	
ISSUE	CHANGES
0	ER 16248 JHP 31 AUG 76
1	CN 21664 C PAS 23 FEB 81
2	CN 22767 E JEP 17 NOV 81
3	CN 25533 D MJB 15 DEC 83
4	CN 27833 A SD 3 MAR 86
5	CN 32302 A LNM 20 JUN 90

KA-19-153

USED ON:	
REF:	
FINISH:	
SPEC. KER 10004	
MATL:	
SPEC:	
TNC BULKHEAD JACK	
DRAWN JHP	DATE 25 AUG 76
APPR. SD	DATE 31 AUG 76

SD

KINGS ELECTRONICS
40 MARLBOROUGH ROAD
TUCKAHOE, N. Y. 10707

M39012/28-0504

ITEM	REQ'D	DESCRIPTION	PART NO.