

Document Title

**64Kx16 Bit High Speed Static RAM(3.3V Operating), Revolutionary Pin out.
Operated at Commercial and Industrial Temperature Range.**

Revision History

<u>RevNo.</u>	<u>History</u>	<u>Draft Data</u>	<u>Remark</u>												
Rev. 0.0	Initial release with Design Target.	Apr. 1st, 1997	Design Target												
Rev. 1.0	Release to Preliminary Data Sheet. 1. Replace Design Target to Preliminary.	Jun. 1st, 1997	Preliminary												
Rev. 2.0	Release to Final Data Sheet. 2.1. Delete Preliminary 2.2. Add Capacitive load of the test environment in A.C test load 2.3. Change D.C characteristics	Feb. 25th, 1998	Final												
	<table border="1"> <thead> <tr> <th>Items</th> <th>Previous spec. (8/10/12ns part)</th> <th>Changed spec. (8/10/12ns part)</th> </tr> </thead> <tbody> <tr> <td>Icc</td> <td>200/190/180mA</td> <td>200/195/190mA</td> </tr> <tr> <td>Isb</td> <td>30mA</td> <td>50mA</td> </tr> </tbody> </table>	Items	Previous spec. (8/10/12ns part)	Changed spec. (8/10/12ns part)	Icc	200/190/180mA	200/195/190mA	Isb	30mA	50mA					
Items	Previous spec. (8/10/12ns part)	Changed spec. (8/10/12ns part)													
Icc	200/190/180mA	200/195/190mA													
Isb	30mA	50mA													
Rev. 2.1	Change Standby and Data Retention Current for L-ver.	Aug. 4th, 1998	Final												
	<table border="1"> <thead> <tr> <th>Items</th> <th>Previous spec.</th> <th>Changed spec.</th> </tr> </thead> <tbody> <tr> <td>Isb</td> <td>0.5mA</td> <td>0.7mA</td> </tr> <tr> <td>I_{DR} at 3.0V</td> <td>0.4mA</td> <td>0.5mA</td> </tr> <tr> <td>I_{DR} at 2.0V</td> <td>0.3mA</td> <td>0.4mA</td> </tr> </tbody> </table>	Items	Previous spec.	Changed spec.	Isb	0.5mA	0.7mA	I _{DR} at 3.0V	0.4mA	0.5mA	I _{DR} at 2.0V	0.3mA	0.4mA		
Items	Previous spec.	Changed spec.													
Isb	0.5mA	0.7mA													
I _{DR} at 3.0V	0.4mA	0.5mA													
I _{DR} at 2.0V	0.3mA	0.4mA													

The attached data sheets are prepared and approved by SAMSUNG Electronics. SAMSUNG Electronics CO., LTD. reserve the right to change the specifications. SAMSUNG Electronics will evaluate and reply to your requests and questions on the parameters of this device. If you have any questions, please contact the SAMSUNG branch office near your office, call or contact Headquarters.

64K x 16 Bit High-Speed CMOS Static RAM(3.3V Operating)

FEATURES

- Fast Access Time 8,10,12ns(Max.)
- Low Power Dissipation
 - Standby (TTL) : 50mA(Max.)
 - (CMOS) : 5mA(Max.)
 - 0.7mA(Max.) - L-Ver. only
- Operating KM616V1002B/BL - 8 : 200mA(Max.)
- KM616V1002B/BL - 10 : 195mA(Max.)
- KM616V1002B/BL - 12 : 190mA(Max.)
- Single 3.3±0.3V Power Supply
- TTL Compatible Inputs and Outputs
- Fully Static Operation
 - No Clock or Refresh required
- Three State Outputs
- 2V Minimum Data Retention ; L-Ver. only
- Center Power/Ground Pin Configuration
- Data Byte Control : LB : I/O1~ I/O8, UB : I/O9~ I/O16
- Standard Pin Configuration
 - KM616V1002BJ : 44-SOJ-400
 - KM616V1002BT : 44-TSOP2-400F

GENERAL DESCRIPTION

The KM616V1002B is a 1,048,576-bit high-speed Static Random Access Memory organized as 65,536 words by 16 bits. The KM616V1002B uses 16 common input and output lines and has an output enable pin which operates faster than address access time at read cycle. Also it allows that lower and upper byte access by data byte control (\overline{UB} , \overline{LB}). The device is fabricated using SAMSUNG's advanced CMOS process and designed for high-speed circuit technology. It is particularly well suited for use in high-density high-speed system applications. The KM616V1002B is packaged in a 400mil 44-pin plastic SOJ or TSOP2 forward.

ORDERING INFORMATION

KM616V1002B/BL -8/10/12	Commercial Temp.
KM616V1002BI/BLI -8/10/12	Industrial Temp.

PIN CONFIGURATION (Top View)

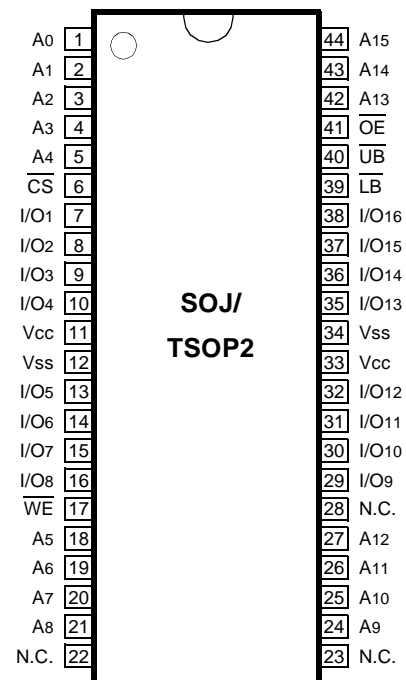

FUNCTIONAL BLOCK DIAGRAM

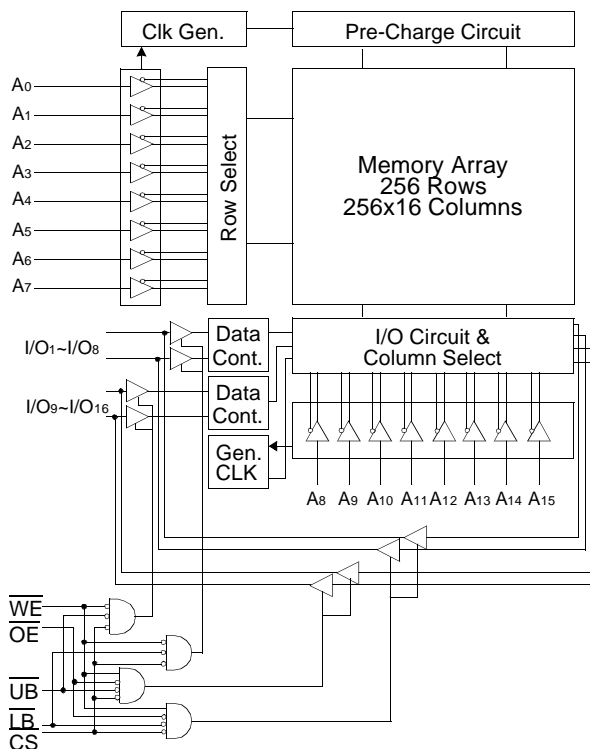

PIN FUNCTION

Pin Name	Pin Function
A0 - A15	Address Inputs
\overline{WE}	Write Enable
\overline{CS}	Chip Select
\overline{OE}	Output Enable
\overline{LB}	Lower-byte Control(I/O1~I/O8)
\overline{UB}	Upper-byte Control(I/O9~I/O16)
I/O1 ~ I/O16	Data Inputs/Outputs
Vcc	Power(+3.3V)
Vss	Ground
N.C	No Connection

ABSOLUTE MAXIMUM RATINGS*

Parameter	Symbol	Rating	Unit	
Voltage on Any Pin Relative to Vss	V _{IN} , V _{OUT}	-0.5 to 4.6	V	
Voltage on Vcc Supply Relative to Vss	V _{CC}	-0.5 to 4.6	V	
Power Dissipation	P _D	1.0	W	
Storage Temperature	T _{STG}	-65 to 150	°C	
Operating Temperature	Commercial	T _A	0 to 70	°C
	Industrial	T _A	-40 to 85	°C

* Stresses greater than those listed under "Absolute Maximum Ratings" may cause permanent damage to the device. This is a stress rating only and functional operation of the device at these or any other conditions above those indicated in the operating sections of this specification is not implied. Exposure to absolute maximum rating conditions for extended periods may affect reliability.

RECOMMENDED DC OPERATING CONDITIONS(T_A=0 to 70°C)

Parameter	Symbol	Min	Typ	Max	Unit
Supply Voltage	V _{CC}	3.0	3.3	3.6	V
Ground	V _{SS}	0	0	0	V
Input High Voltage	V _{IH}	2.0	-	V _{CC} +0.3**	V
Input Low Voltage	V _{IL}	-0.3*	-	0.8	V

NOTE: The above parameters are also guaranteed at industrial temperature range.

* V_{IL}(Min) = -2.0V a.c(Pulse Width ≤ 6ns) for I ≤ 20mA

** V_{IH}(Max) = V_{CC} + 2.0V a.c (Pulse Width ≤ 6ns) for I ≤ 20mA

DC AND OPERATING CHARACTERISTICS(T_A=0 to 70°C, V_{CC}=3.3±0.3V, unless otherwise specified)

Parameter	Symbol	Test Conditions	Min	Max	Unit	
Input Leakage Current	I _{LI}	V _{IN} =V _{SS} to V _{CC}	-2	2	μA	
Output Leakage Current	I _{LO}	\overline{CS} =V _{IH} or \overline{OE} =V _{IH} or \overline{WE} =V _{IL} V _{OUT} =V _{SS} to V _{CC}	-2	2	μA	
Operating Current	I _{CC}	Min. Cycle, 100% Duty CS=V _{IL} , V _{IN} =V _{IH} or V _{IL} , I _{OUT} =0mA	8ns	-	200	mA
			10ns	-	195	
			12ns	-	190	
Standby Current	I _{SB}	Min. Cycle, \overline{CS} =V _{IH}	-	50	mA	
	I _{SB1}	f=0MHz, \overline{CS} ≥V _{CC} -0.2V, V _{IN} ≥V _{CC} -0.2V or V _{IN} ≤0.2V	Normal	-		5
L-Ver.			-	0.7		
Output Low Voltage Level	V _{OL}	I _{OL} =8mA	-	0.4	V	
Output High Voltage Level	V _{OH}	I _{OH} =-4mA	2.4	-	V	

NOTE: The above parameters are also guaranteed at industrial temperature range.

CAPACITANCE*(T_A=25°C, f=1.0MHz)

Item	Symbol	Test Conditions	MIN	Max	Unit
Input/Output Capacitance	C _{I/O}	V _{I/O} =0V	-	8	pF
Input Capacitance	C _{IN}	V _{IN} =0V	-	6	pF

* NOTE : Capacitance is sampled and not 100% tested.

AC CHARACTERISTICS (TA=0 to 70°C, VCC=3.3±0.3V, unless otherwise noted.)

TEST CONDITIONS

Parameter	Value
Input Pulse Levels	0V to 3V
Input Rise and Fall Times	3ns
Input and Output timing Reference Levels	1.5V
Output Loads	See below

NOTE: The above test conditions are also applied at industrial temperature range.

Output Loads(A)

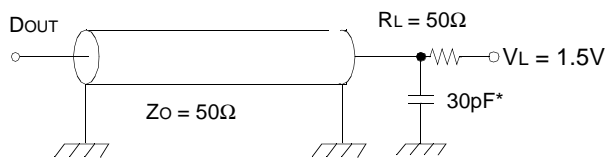

Output Loads(B)

for tHZ, tLZ, tWHZ, tOW, tOLZ & tOHZ

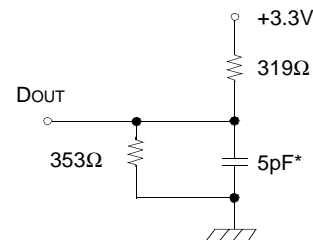

* Capacitive Load consists of all components of the test environment.

* Including Scope and Jig Capacitance

READ CYCLE

Parameter	Symbol	KM616V1002B/BL-8		KM616V1002B/BL-10		KM616V1002B/BL-12		Unit
		Min	Max	Min	Max	Min	Max	
Read Cycle Time	tRC	8	-	10	-	12	-	ns
Address Access Time	tAA	-	8	-	10	-	12	ns
Chip Select to Output	tCO	-	8	-	10	-	12	ns
Output Enable to Valid Output	tOE	-	4	-	5	-	6	ns
\overline{UB} , \overline{LB} Access Time	tBA	-	8	-	10	-	12	ns
Chip Enable to Low-Z Output	tLZ	3	-	3	-	3	-	ns
Output Enable to Low-Z Output	tOLZ	0	-	0	-	0	-	ns
\overline{UB} , \overline{LB} Enable to Low-Z Output	tBLZ	0	-	0	-	0	-	ns
Chip Disable to High-Z Output	tHZ	0	4	0	5	0	6	ns
Output Disable to High-Z Output	tOHZ	0	4	0	5	0	6	ns
\overline{UB} , \overline{LB} Disable to High-Z Output	tBHZ	0	4	0	5	0	6	ns
Output Hold from Address Change	tOH	3	-	3	-	3	-	ns

NOTE: The above parameters are also guaranteed at industrial temperature range.

WRITE CYCLE

Parameter	Symbol	KM616V1002B/BL-8		KM616V1002B/BL-10		KM616V1002B/BL-12		Unit
		Min	Max	Min	Max	Min	Max	
Write Cycle Time	tWC	8	-	10	-	12	-	ns
Chip Select to End of Write	tCW	6	-	7	-	8	-	ns
Address Set-up Time	tAS	0	-	0	-	0	-	ns
Address Valid to End of Write	tAW	6	-	7	-	8	-	ns
Write Pulse Width(\overline{OE} High)	tWP	6	-	7	-	8	-	ns
Write Pulse Width(\overline{OE} Low)	tWP1	8	-	10	-	12	-	ns
\overline{UB} , \overline{LB} Valid to End of Write	tBW	6	-	7	-	8	-	ns
Write Recovery Time	tWR	0	-	0	-	0	-	ns
Write to Output High-Z	tWHZ	0	4	0	5	0	6	ns
Data to Write Time Overlap	tdW	4	-	5	-	6	-	ns
Data Hold from Write Time	tdH	0	-	0	-	0	-	ns
End Write to Output Low-Z	tOW	3	-	3	-	3	-	ns

NOTE: The above parameters are also guaranteed at industrial temperature range.

TIMMING DIAGRAMS

TIMING WAVEFORM OF READ CYCLE(1) (Address Controlled, $\overline{CS}=\overline{OE}=V_{IL}$, $\overline{WE}=V_{IH}$, \overline{UB} , $\overline{LB}=V_{IL}$)

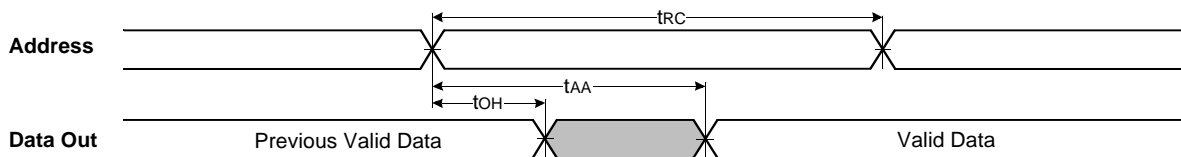

TIMING WAVEFORM OF READ CYCLE(2) ($\overline{WE}=V_{IH}$)

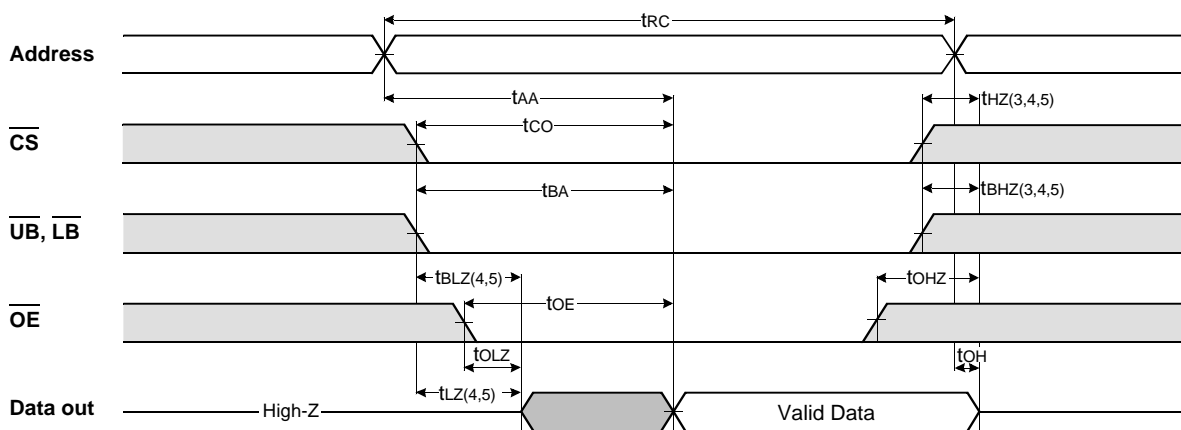

NOTES(READ CYCLE)

- \overline{WE} is high for read cycle.
- All read cycle timing is referenced from the last valid address to the first transition address.
- tHZ and tOHZ are defined as the time at which the outputs achieve the open circuit condition and are not referenced to V_{OH} or V_{OL} levels.
- At any given temperature and voltage condition, tHZ(Max.) is less than tLZ(Min.) both for a given device and from device to device.
- Transition is measured $\pm 200mV$ from steady state voltage with Load(B). This parameter is sampled and not 100% tested.
- Device is continuously selected with $\overline{CS}=V_{IL}$.
- Address valid prior to coincident with \overline{CS} transition low.
- For common I/O applications, minimization or elimination of bus contention conditions is necessary during read and write cycle.

TIMING WAVEFORM OF WRITE CYCLE(1) (\overline{OE} =Clock)

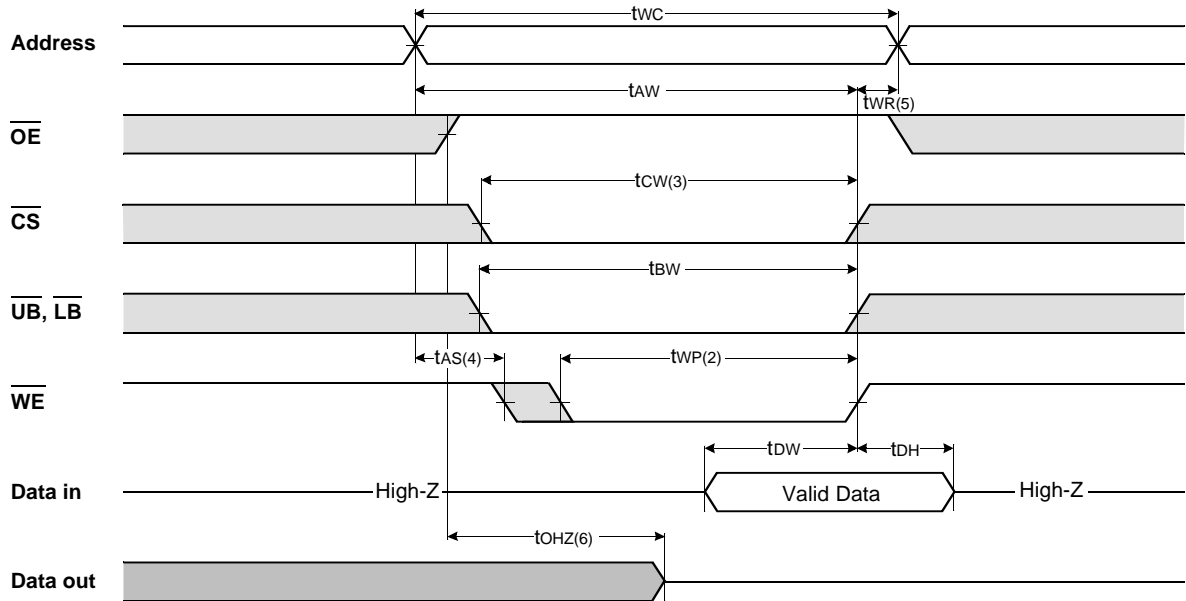

TIMING WAVEFORM OF WRITE CYCLE(2) (\overline{OE} =Low fixed)

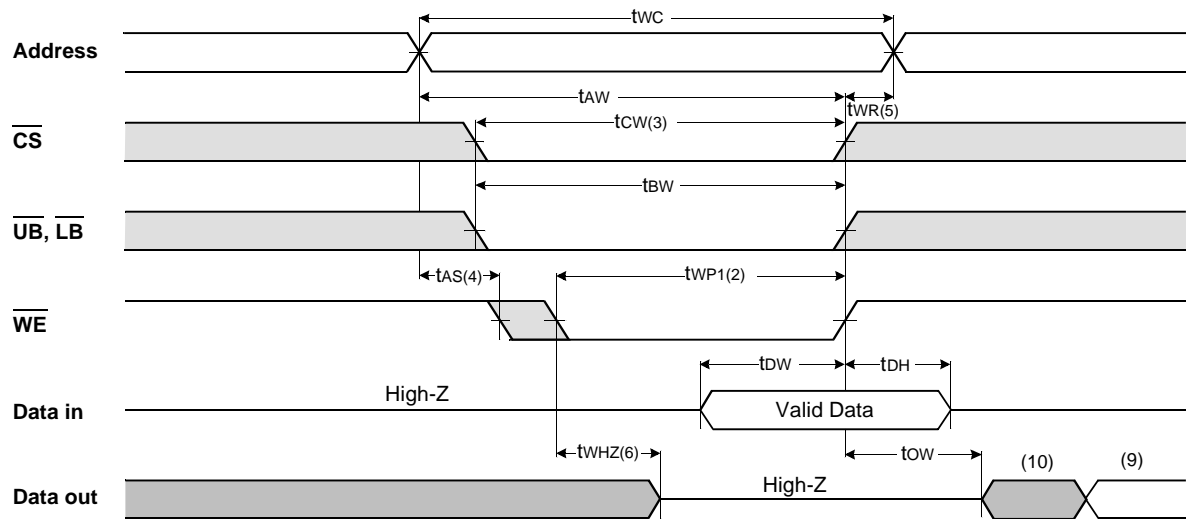

TIMING WAVEFORM OF WRITE CYCLE(3) (\overline{CS} =Controlled)

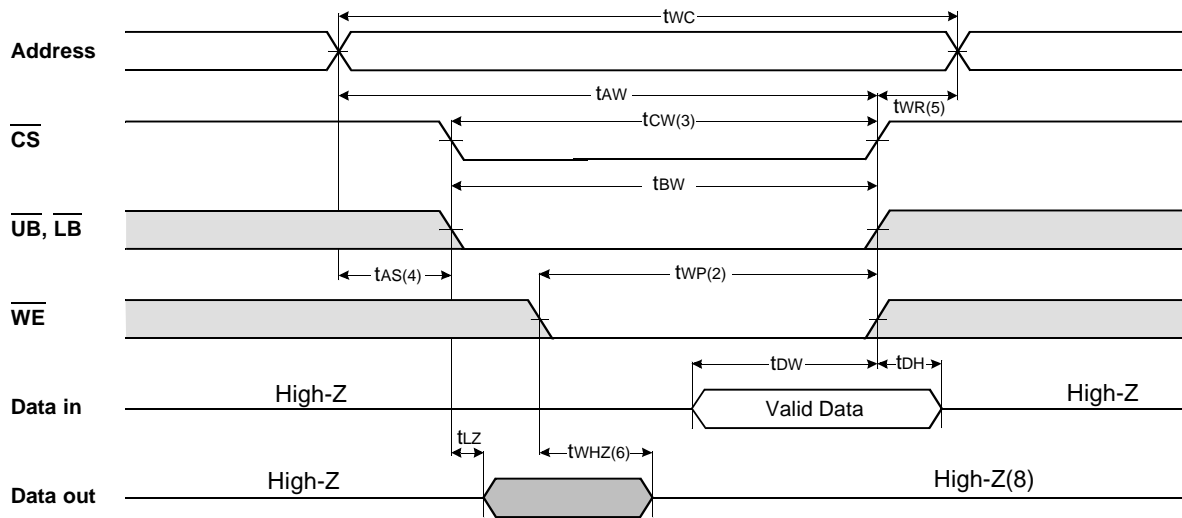

TIMING WAVEFORM OF WRITE CYCLE(4) (\overline{UB} , \overline{LB} Controlled)

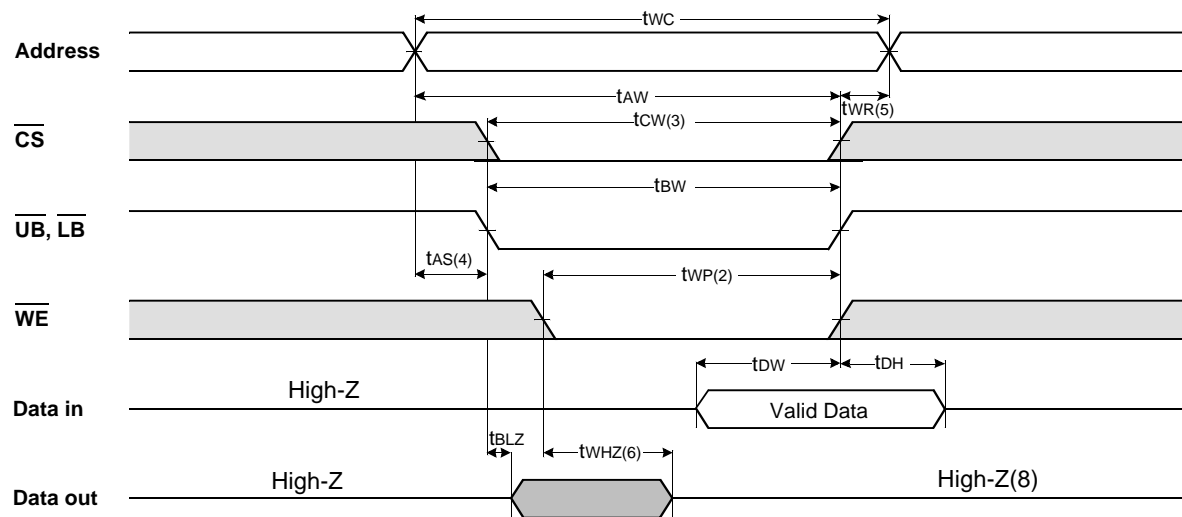

NOTES(WRITE CYCLE)

1. All write cycle timing is referenced from the last valid address to the first transition address.
2. A write occurs during the overlap of a low \overline{CS} , \overline{WE} , \overline{LB} and \overline{UB} . A write begins at the latest transition \overline{CS} going low and \overline{WE} going low ; A write ends at the earliest transition \overline{CS} going high or \overline{WE} going high. t_{WP} is measured from the beginning of write to the end of write.
3. t_{CW} is measured from the later of \overline{CS} going low to end of write.
4. t_{AS} is measured from the address valid to the beginning of write.
5. t_{WR} is measured from the end of write to the address change. t_{WR} applied in case a write ends as \overline{CS} or \overline{WE} going high.
6. If \overline{OE} , \overline{CS} and \overline{WE} are in the Read Mode during this period, the I/O pins are in the output low-Z state. Inputs of opposite phase of the output must not be applied because bus contention can occur.
7. For common I/O applications, minimization or elimination of bus contention conditions is necessary during read and write cycle.
8. If \overline{CS} goes low simultaneously with \overline{WE} going or after \overline{WE} going low, the outputs remain high impedance state.
9. D_{out} is the read data of the new address.
10. When \overline{CS} is low : I/O pins are in the output state. The input signals in the opposite phase leading to the output should not be applied.

FUNCTIONAL DESCRIPTION

\overline{CS}	\overline{WE}	\overline{OE}	\overline{LB}	\overline{UB}	Mode	I/O Pin		Supply Current
						I/O ₁ ~I/O ₈	I/O ₉ ~I/O ₁₆	
H	X	X*	X	X	Not Select	High-Z	High-Z	ISB, ISB1
L	H	H	X	X	Output Disable	High-Z	High-Z	I _{CC}
L	X	X	H	H				
L	H	L	L	H	Read	DOUT	High-Z	I _{CC}
			H	L		High-Z	DOUT	
			L	L		DOUT	DOUT	
L	L	X	L	H	Write	DIN	High-Z	I _{CC}
			H	L		High-Z	DIN	
			L	L		DIN	DIN	

* NOTE : X means Don't Care.

DATA RETENTION CHARACTERISTICS*(T_A=0 to 70°C)

Parameter	Symbol	Test Condition	Min.	Typ.	Max.	Unit
V _{CC} for Data Retention	V _{DR}	$\overline{CS} \geq V_{CC} - 0.2V$	2.0	-	3.6	V
Data Retention Current	I _{DR}	V _{CC} =3.0V, $\overline{CS} \geq V_{CC} - 0.2V$ V _{IN} ≥ V _{CC} -0.2V or V _{IN} ≤ 0.2V	-	-	0.5	mA
		V _{CC} =2.0V, $\overline{CS} \geq V_{CC} - 0.2V$ V _{IN} ≥ V _{CC} -0.2V or V _{IN} ≤ 0.2V	-	-	0.4	
Data Retention Set-Up Time	t _{SDR}	See Data Retention Wave form(below)	0	-	-	ns
Recovery Time	t _{RDR}		5	-	-	ms

NOTE: The above parameters are also guaranteed at industrial temperature range.
* L-Ver only.

DATA RETENTION WAVE FORM

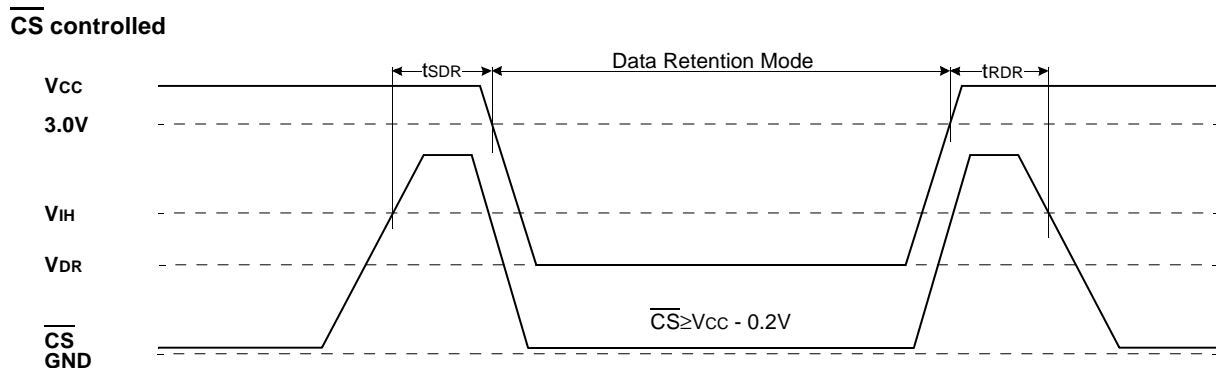

PACKAGE DIMENSIONS

44-SOJ-400

Units: millimeters/Inches

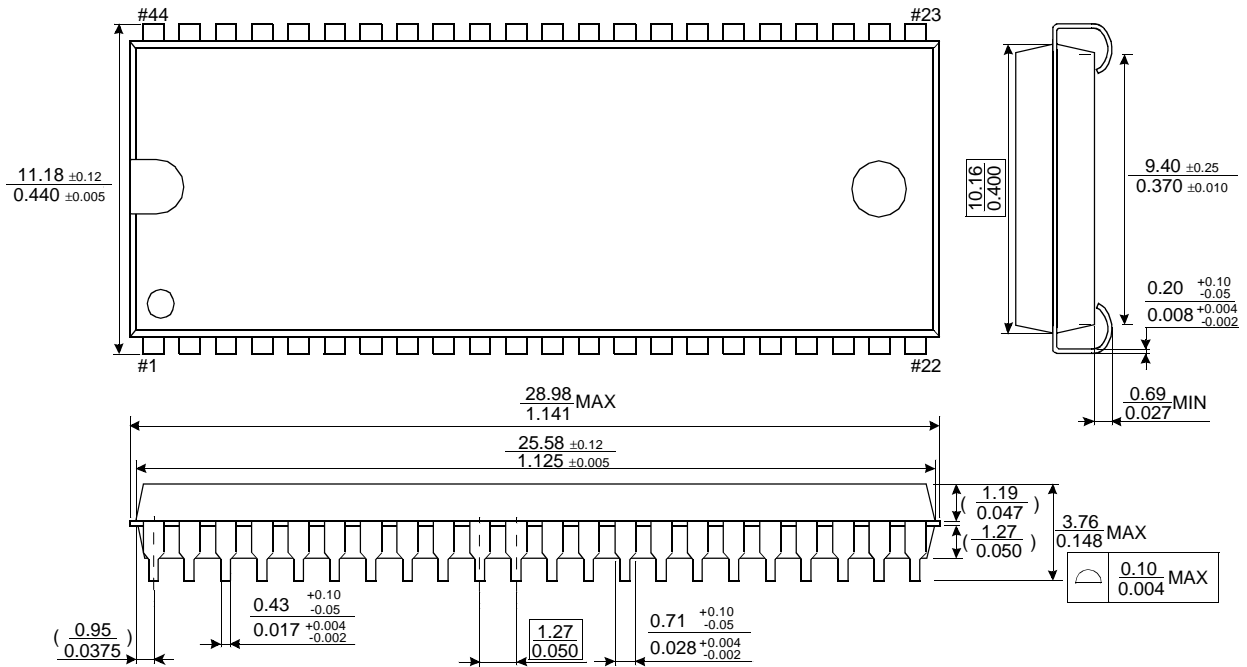

44-TSOP2-400F

Units: millimeters/Inches

