

75 AMP OVERVOLTAGE TRANSIENT SUPPRESSORS

FEATURES

- VOID FREE VACUUM DIE SOLDERING FOR MAXIMUM MECHANICAL STRENGTH AND HEAT DISSIPATION (Solder Voids: Typical $\leq 2\%$, Max. $\leq 10\%$ of Die Area)
- LARGE DIE FOR HIGH POWER HEAVY DUTY PERFORMANCE
- HIGH HEAT HANDLING CAPABILITY WITH VERY LOW THERMAL STRESS
- PROPRIETARY JUNCTION PASSIVATION FOR SUPERIOR RELIABILITY AND PERFORMANCE
- LOW FORWARD VOLTAGE DROP

MECHANICAL SPECIFICATION

Die Size:
0.250" Dia.
Round

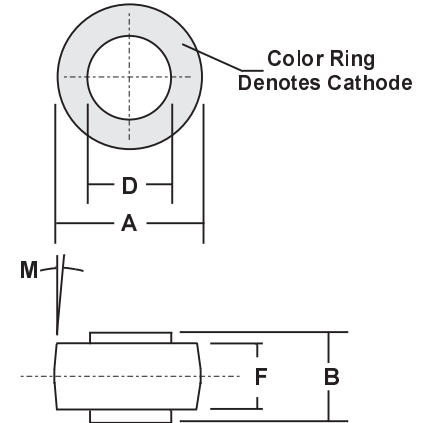

MECHANICAL DATA

- Case: Molded Epoxy (UL Flammability Rating 94V-0)
- Finish: All external surfaces are silver plated for corrosion resistance superior solderability
- Soldering Temperature: 210 °C maximum
- Mounting Position: Any
- Polarity: Color band denotes cathode
- Weight: 0.06 Ounces (1.8 Grams)

RoHS COMPLIANT

Dim	Millimeters		Inches	
	Min	Max	Min	Max
A	9.78	10.29	0.385	0.405
B	5.97	6.35	0.235	0.250
D	5.46	5.71	0.215	0.225
F	4.19	4.45	0.165	0.175
M	5° NOM		5° NOM	

MAXIMUM RATINGS & ELECTRICAL CHARACTERISTICS

Ratings at 25 °C ambient temperature unless otherwise specified.
 Single phase, half wave, 60 Hz resistive or inductive load.

PARAMETER (TEST CONDITIONS)	SYMBOL	RATINGS	UNITS
Series Number		TVS7527	
Maximum Recurrent Peak Reverse Voltage	VRRM	23	VOLTS
Working Peak Reverse Voltage	VRWM		
Maximum DC Blocking Voltage	V _{DC}		
Breakdown Voltage (I _R = 100 mA dc, T _c = 25 °C)	V _(BR)	24 Min / 32 Max	
Average Forward Rectified Current	I _O	75	AMPS
Non-repetitive Peak Forward Surge Current (Half wave, single phase, 60 Hz sine applied to rated load)	I _{FSM}	800	
Repetitive Peak Reverse Surge Current (Time Constant = 10 mSec Duty Cycle $\leq 1.0\%$, T _c = 25 °C)	I _{RSM}	150	
Instantaneous Forward Voltage (I _F = 100A @ 300 μ Sec pulse, T _c = 25 °C)	V _F	1.05	VOLTS
Maximum Typical		1.00	
Maximum DC Reverse Current (V _R = 20V DC, T _c = 25 °C)	I _R	200	nA
Maximum Thermal Resistance, Junction to Case (Note 1)	R _{θJC}	0.8	°C/W
Junction Operating & Storage Temperature Range	T _J , T _{STG}	-65 to +175	°C

Notes: 1) Single Side Cooled