

DASH NO.	DESCRIPTION	MADE FROM
----------	-------------	-----------

S-D

REVISIONS	
ISSUE	CHANGES
0	ER 1773B GA 17 OCT 77
1	CN 21652 C HELEN 23 FEB 81
2	CN 26535 D MID ADDRESS
3	CN 28700 A CHE 5 AUG 86
4	CN 31016 A JCA 27 JUL 89
5	CN 32301 A LNM 19 JUN 90

M39012/26-0501

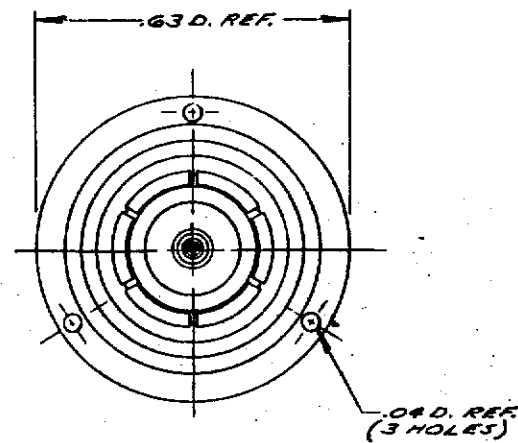
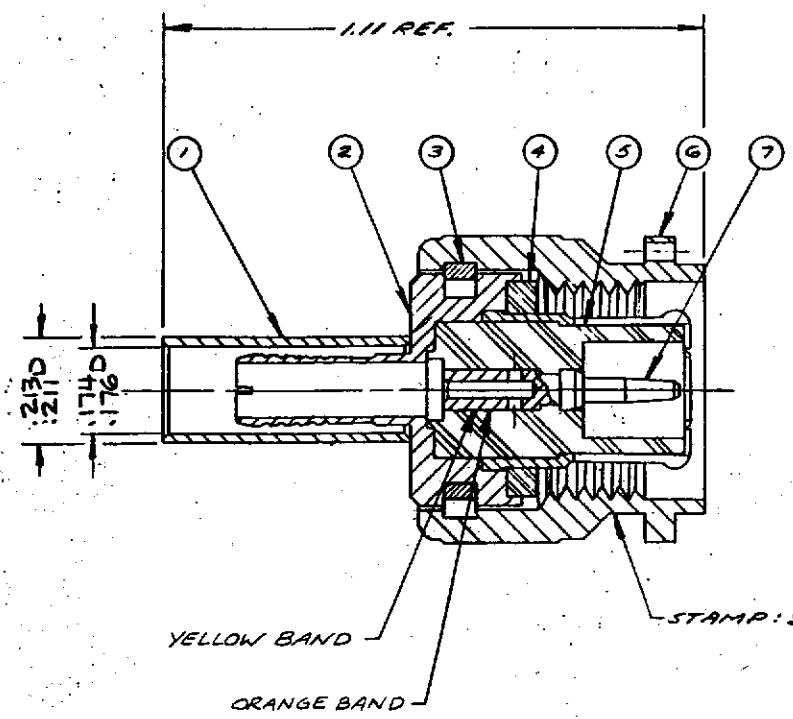

- NOTES:**
- FOR USE WITH RG-122/U CABLE.
  - FOR CABLE TRIMMING USE KT-J-116 & KTO-161.
  - FOR FORMING USE CRIMP DIE SIZE 07.
  - FOR CABLING INSTRUCTIONS SEE CP-465.
  - ITEM ⑦ TO BE SUPPLIED UNASSEMBLED.
  - SAME AS KA-59-291 EXCEPT ITEM ⑦ & MARKINGS.

**UNLESS OTHERWISE SPECIFIED:**

- |  |  |
|--|--|
| 1. TOLERANCES: FRACTIONS & 2 PLACE DECIMALS ± .010   | 2. REMOVE ALL BURRS, BREAK SHARP EDGES .005 MAX. |
| 3 PLACE DECIMALS ± .004  | 3. NO FILLETS PERMITTED                          |
| 4. ANGLES ± 0° 30'   | 4. SURFACE FINISHNESS 63 MICROINCHES RMS MAX.    |
| 5. T. I. R. CONCENTRICITY OF ANY 2 DIAMETERS MAY NOT EXCEED HALF THE SUM OF THEIR TOLERANCES | 5. ALL DIMENSIONS PRIOR TO PLATING.              |

ITEM	REQ'D	DESCRIPTION	PART NO.
8	1	CABLING INSTRUCTIONS	3-102-2M88
7	1	BNC CRIMP CAPTIVE CONTACT	1-569-918M9D
6	1	COUPLING NUT	
5	1	INSULATOR	
4	1	GASKET	
3	1	O-RING	
2	1	BODY ASS'Y.	
1	1	K-GRIP SLEEVE	1-4690-2M67

S-D

**KA-59-290**

USED ON:

REF:

FINISH:

SPEC:

MATL:

SPEC:

**TNC PLUG**

DRAWN JCA DATE 14 JUN 89

APPR. DATE

**KINGS ELECTRONICS**  
40 HANSDALE ROAD  
TUCKAHOE, N. Y. 10707

**M39012/26-0501**