

features

- Performs like RK73 under normal conditions
- Fuses when overloaded
- Marking: Black three-digit on brown protective coating
1J: No marking
- Products with lead-free terminations meet EU RoHS requirements. EU RoHS regulation is not intended for Pb-glass contained in electrode, resistor element and glass.

dimensions and construction

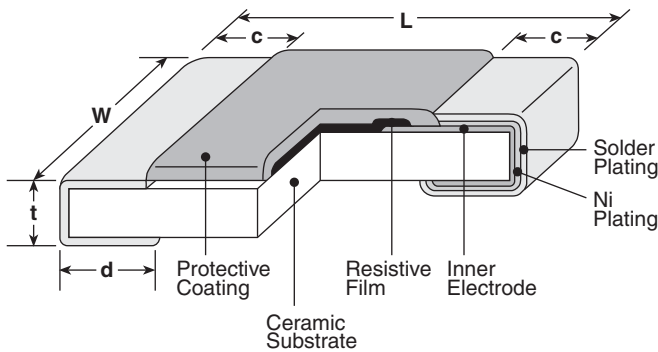

Type (Inch Size Code)	Dimensions inches (mm)				
	L	W	c	d	t
1J (0603)	.063±.008 (1.6±0.2)	.031±.004 (0.8±0.1)	.012±.004 (0.3±0.1)	.012±.004 (0.3±0.1)	.02±.004 (0.5±0.1)
2A (0805)	.079±.008 (2.0±0.2)	.049±.004 (1.25±0.1)	.016±.008 (0.4±0.2)	.012 ^{+0.008} _{-.004} (0.3 ^{+0.2} _{-.1})	
2B (1206)	.126±.008 (3.2±0.2)	.063±.008 (1.6±0.2)	.02±.012 (0.5±0.3)	.016 ^{+0.008} _{-.004} (0.4 ^{+0.2} _{-.1})	.024±.004 (0.6±0.1)
2E (1210)		.102±.008 (2.6±0.2)			
2H (2010)	.197±.008 (5.0±0.2)	.098±.008 (2.5±0.2)			
3A (2512)	.248±.008 (6.3±0.2)	.122±.008 (3.1±0.2)			

ordering information

New Part #	RF73	2B	T	TD	100	J
Type		Size Code	Termination Material	Packaging	Nominal Resistance	Tolerance
		1J: 0603 2A: 0805 2B: 1206 2E: 1210 2H: 2010 3A: 2512	T: Sn (Other termination styles may be available, please contact factory for options)	TD: 7" paper tape (0603, 0805, 1206, 1210: 5,000 pieces/reel) TE: 7" embossed plastic (0805, 1206, 1210, 2010, 2512: 4,000 pieces/reel)	2 significant figures + 1 multiplier "R" indicates decimal on value <10Ω	J: ±5%

For further information on packaging, please refer to Appendix A.

applications and ratings

Part Designation	Power Rating @ 70°C	T.C.R. (ppm/°C) Max.	Resistance Range E-24*	Resistance Tolerance	Maximum Open Circuit Voltage	Fusing Characteristics					Fusing Time	Operating Temperature Range
						Fusing Power						
RF731J	0.063W	+1000 ~ -500 (1.0Ω-3.3Ω) ±500 (3.6Ω-100Ω)	1Ω-100Ω	J: ±5%	50V	—	2.6W 1.0Ω	2.4W 1.1Ω-20Ω	2.1W 22Ω-100Ω	—	60 sec. max.	-55°C to +125°C
RF732A	0.1W	+1000 ~ -500 (0.2Ω-4.3Ω) ±500 (4.7Ω-510Ω)	0.2Ω-510Ω			3.0W 0.2Ω-0.47Ω	2.6W 0.51Ω-1.0Ω	2.4W 1.1Ω-20Ω	2.1W 22Ω-100Ω	2.0W 110Ω-510Ω		
RF732B	0.125W					3.75W 0.2Ω-0.47Ω	2.875W 0.51Ω-1.0Ω	2.5W 11Ω-24Ω	2.0W 27Ω-100Ω	1.75W 110Ω-510Ω		
RF732E	0.25W					4.5W 0.2Ω-0.47Ω	4.1W 0.51Ω-4.7Ω	3.5W 5.1Ω-27Ω	3.2W 30Ω-100Ω	3.0W 110Ω-510Ω		
RF732H	0.50W					5.5W 0.2Ω-0.47Ω	5.0W 0.51Ω-4.7Ω	4.0W 5.1Ω-27Ω	3.5W 30Ω-100Ω	3.2W 110Ω-510Ω		
RF733A	1.0W					6.5W 0.2Ω-0.47Ω	6.0W 0.51Ω-4.7Ω	5.0W 5.1Ω-30Ω	4.5W 33Ω-100Ω	4.0W 110Ω-510Ω		

environmental applications

Derating Curve

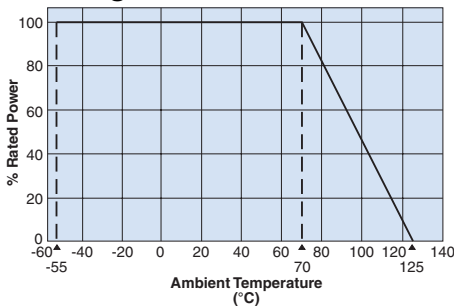

For resistors operated at an ambient temperature of 70°C or above, a power rating shall be derated in accordance with the above derating curve.

One-Pulse Limiting Electric Power

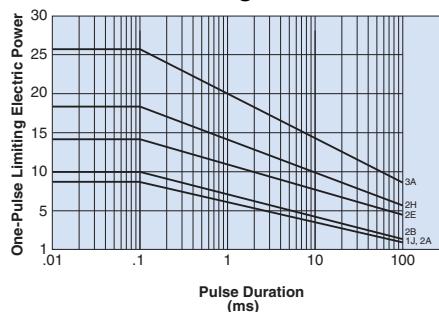

Example of Fusing Characteristics

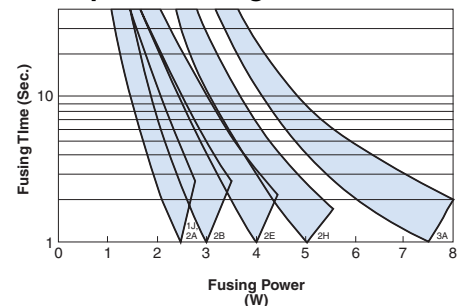

Performance Characteristics

Parameter	Requirement $\Delta R \pm(\% + 0.1\Omega)$		Test Method
	Limit	Typical	
Resistance	Within specified tolerance	—	25°C
T.C.R.	Within specified T.C.R.	—	+25°C/-55°C and +25°C/+125°C
Overload (Short Time)	±5.0%	±2.0%	Rated voltage x 2 for 5 seconds (except 2E, 2H, 3A: x 1.5)
Resistance to Solder Heat	±3.0%	0.5%	260°C ± 5°C for 10 seconds ± 1 second
Rapid Change of Temperature	±0.5%: 2A~3A ±3.0%: 1J	±0.3%: 2A~3A ±0.6%: 1J	-55°C (30 minutes)/ +125°C (30 minutes) 5 cycles
Moisture Resistance	±5.0%	±2.0%	40°C ± 2°C, 90 - 95% RH, 500 hours, 1.5 hr ON, 0.5 hr OFF cycle
Endurance at 70°C	±5.0%	±1.0%	70°C ± 2°C, 1000 hours, 1.5 hr ON, 0.5 hr OFF cycle
High Temperature Exposure	±1.0%	±0.6%	+125°C, 100 hours