

REV	DESCRIPTION	BY DATE	APPD
01	PRELIMINARY PER ER30232	DRK 01/26/11	XXX

- NOTES: UNLESS OTHERWISE SPECIFIED
- INTERFACE COMPLIANT TO SMPTE 304 SPECIFICATION.
 - MATERIAL SPECIFICATIONS:
CONTACTS: COPPER ALLOY
O-RINGS AND STRAIN RELIEF: SILICONE RUBBER
ALL PLASTIC PARTS: 20% GLASS FILLED POLYPROPYLENE
ALL OTHER METAL PARTS: 303 STAINLESS STEEL PER ASTM A582
 - FINISH SPECIFICATIONS:
STAINLESS STEEL PARTS: PASSIVATE
CONTACTS: .000100 MIN GOLD PER ASTM B488 OVER
.000080 MIN NICKEL PER AMS-QQN-290 (RoHS)
 - ELECTRICAL SPECIFICATIONS:
LOW VOLTAGE CONTACTS: 42 - 60 VAC, 1 AMP
AUX ELECTRICAL CONTACTS: 600 VAC, 10 AMP
 - ENVIRONMENTAL:
OPERATING TEMPERATURE RATING: -40°C TO 75°C
NON-OPERATING/STORAGE TEMPERATURE RATING: -40°C TO 85°C
HUMIDITY: <95 RH (AT 40°C)
 - OPTICAL:
WAVELENGTH: 1250nm - 1625nm
INSERTION LOSS: 0.3dB TYPICAL, 0.5dB MAX
RETURN LOSS: > -45dB, -50dB TYPICAL
 - REPLACEMENT KITS:
CONTACT KIT: 7760-000-00701Z
CONTACT KIT WITH CARTRIDGE: 7760-000-00703Z
 - CABLE PREPARATION AND STRIPPING PROCEDURE: CAP-TBD.
 - RED LDPE DUST CAP INCLUDED (NOT SHOWN)
 - CRIMP TOOLING:
FOR FACTORY APPLICATION USE HAND TOOL KTH-1000 AND DIE KTH-2035
FOR FIELD APPLICATION USE HAND TOOL KTH-5000 AND DIE KTH-5018
 - ELECTRICAL AND OPTICAL CONTACTS INCLUDED

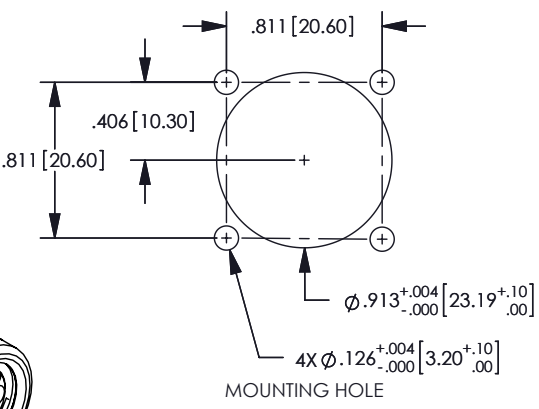
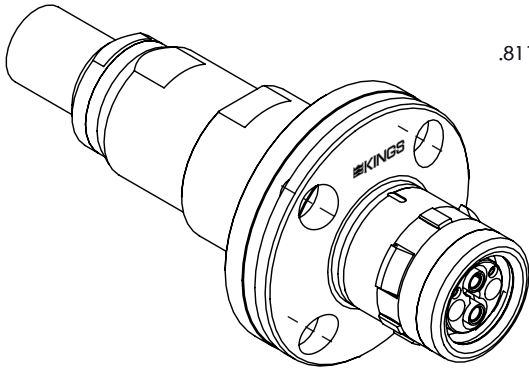
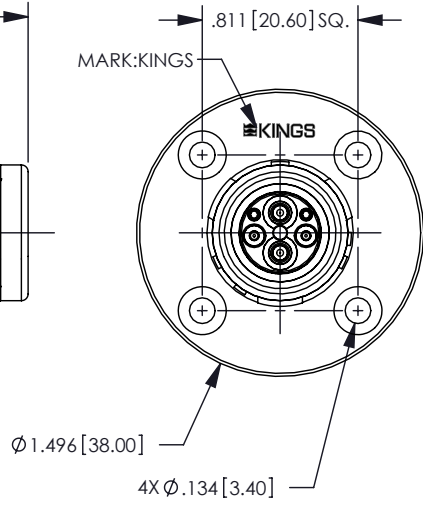
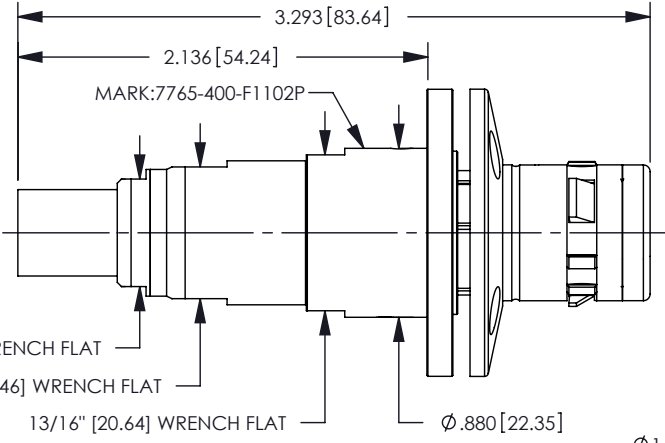

CATALOG P/N: 7765-400-F1102P

PER ASME Y14.5M-1994 UNLESS OTHERWISE SPECIFIED: DIMENSIONS ARE IN INCHES [MM] TOLERANCES: DECIMAL: XX [X.X] ± .01 [0.3] .XXX [X.XX] ± .005 [0.13] .XXXX [X.XXX] ± .XXXX ANGLES: ± 2° SCALE: 1:1				 by WINCHESTER Winchester Electronics Corporation 62 Barnes Industrial Road North Wallingford, Connecticut 06492						
CUSTOMER SALES DRAWING				THIRD ANGLE 		TRI LOCK SMPTE PANEL MOUNT 4 HOLE, PLUG, CABLE				
DRAWN	DATE	APPROVED	DATE	DRAWN	DATE	APPROVED	DATE	SHT	OF	REV
DRK	01/26/11	PSM	02/01/11	DRK	01/26/11	PSM	02/01/11	1	1	01
APPROVED	DATE	APPROVED	DATE	A SD7765-400-F1102P						
JCF	02/01/11	XXX	XX/XX/XX							