



A Division of Pittway  
 3825 Ohio Avenue, St. Charles, Illinois 60174  
 1-800-SENSOR2, FAX: 630-377-6495

**2412AT, 2424AT, and 2424AIT  
 Direct Wire Photoelectronic with  
 Fixed Heat Smoke Detectors**

**Specifications**

Diameter:	5.5 inches (14 cm)	
Height, with Thermal:	3.19 inches (8.1 cm)	
Weight:	0.7 lb. (310 g)	
Operating Temperature:	0° to 38° C (32° to 100° F)	
Operating Humidity:	10% to 95% Relative Humidity Non-condensing	
Visual Indicator:	Solid State LED	
Locking Alarm:	Reset by momentary power interruption	
Audible Signal:	85dBA minimum interrupted tone when individual unit is in alarm or when the supply voltage is reversed.	

<b>Electrical Ratings:</b>	<b>2412AT</b>	<b>2424AT or 2424AIT</b>
Operating Voltage:	12VDC	24VDC
	Full-wave, Unfiltered	Full-wave, Unfiltered

Current		
Standby:	120 $\mu$ A Max.	120 $\mu$ A Max.
Alarm:	51mA	43mA
	(Add 7mA Maximum with RA400Z Remote Annunciator LED)	
Reversed Supply:	8mA	15mA
Start-up Time:	36 seconds maximum	
Relay Characteristics:	One Form A (SPST-NO) for alarm initiation 1.25A at 30 VAC/DC	

**Before Installing**

Please thoroughly read the System Sensor manual I56-407-XX, *Guide for Proper Use of System Smoke Detectors*, which provides detailed information on detector spacing, placement, zoning, wiring, and special applications. Copies of this manual are available at no charge from System Sensor. (For installations in Canada refer to CAN\ULC-S524, *Standard for the Installation of Fire Alarm Systems* and CEC Part 1, Sec. 32.)

**General Description**

System Sensor 2412AT, 2424AT and 2424AIT photoelectronic smoke detectors are designed to provide open area protection and to be used with UL-listed 4-wire control panels. The 2412AT operates at 12 VDC and the 2424AT and 2424AIT operate at 24 VDC. The sensor in this detector operates on the light scattering principle and features a unique photo-optic sensing chamber that provides good smoke entry while minimizing the effects of ambient light. These detectors also provide restorable 135°F fixed-temperature heat detection. The 2412AT and 2424AT heat detection unit is integrated with the photoelectronic sensor while the 2424AIT's heat detection unit is isolated from the photoelectronic smoke sensor and can be monitored separately. In addition, a piezoelectric horn in each detector produces an interrupted, 85 dBA

minimum tone when the individual detector alarms or when the supply voltage polarity is reversed.

An LED on each detector lights to provide a local alarm indication and will remain on when the supply polarity is reversed. A screw terminal is provided for a remote LED annunciator optional accessory (RA400Z). These detectors are listed to UL268 and are latching type system detectors. The alarm can be reset only by momentary power interruption. For testing, these detectors have a test switch or may be tested by inserting a calibrated test card in a test slot after removing the detector's cover.

Each detector contains one Form A (SPST-NO) contact for connection to an alarm-initiating circuit. Supervision of the detector power is accomplished by installing a Power Supervisory End-of-Line Relay Module (A77-716) at the end of the detector power loop. When power is applied to and through the detectors, the EOL Power Supervisory Module is energized. Its relay contacts close and provide a closed series circuit in the control panel's alarm-initiating loop. A power failure or break in the detector power loop de-energizes the EOL Module. The relay contacts open and trigger a trouble signal at the control panel.

**Figure 1. Flush mounting of detector on 4-inch octagon box:**

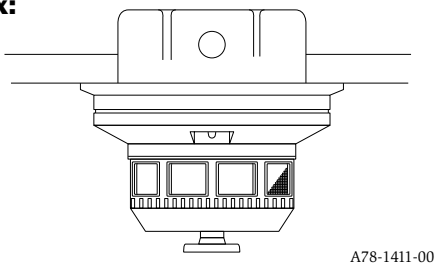

A78-1411-00

**Figure 2. Detector mounting bracket:**

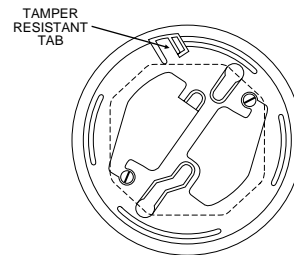

TO MAKE DETECTOR TAMPER RESISTANT, BREAK OFF TAB EXTENSION AT SCRIBED LINE

A78-534-00

**Mounting Instructions**

Each 2400 Series detector unit is supplied with a mounting bracket kit that permits several mounting techniques:

1. Units may be mounted directly to a 3-inch or 4-inch octagonal, 1½ inch deep electrical box. (See Figures 1 and 2.)
2. Units may be mounted to a 4-inch square electrical box by using plaster ring with the supplied mounting bracket kit.

**Tamper-proof Feature**

This detector includes a tamper-proof feature that, when activated, prevents removal of the detector without the use of a tool. To activate this feature, cut off smaller tab at the scribe line on tamper-proof tab located on the detector mounting bracket (see Figure 2). Install the detector. To remove the detector from the bracket once the tamper-proof feature has been activated, depress the tamper-proof tab located in the slot on the mounting bracket and turn the detector counterclockwise for removal.

**Installation In Australia Only**

The installation temperature range for Australia is 5° to 45°C and has been tested per the Australian Standard. Ignore installation temperatures specified for all other applications when installing detectors in Australia. Detectors should be installed by qualified technicians. Installation of a mains connected power supply unit must be performed by qualified electricians only. The primary power will be provided by a panel type system. A rechargeable battery is required as a backup to the external power supply in case of a mains failure. In standby operation, the backup battery (fully charged) must be capable of providing uninterrupted power for at least 7 days to the

system and all smoke alarms before the panel gives the required battery-low signal. When the battery-low signal is given, the battery should be capable of providing power for another 7 days, after which the backup battery should have enough energy left to allow a 4-minute alarm signal to be given by all connected smoke alarms.

**Wiring Installation Guidelines**

All wiring must be in compliance with the National Electrical Code and the applicable local codes, and any special requirements of the local authority having jurisdiction. Proper wire gauges should be used. The conductors used to connect smoke detectors to control panels and accessory devices should be color-coded to prevent wiring mistakes. Improper connections can prevent a system from responding properly in the event of a fire.

For signal wiring (the wiring between interconnected detectors), wire no smaller than 18 AWG is recommended. Wire sizes up to 12 AWG may be used. For best system performance, the power (+ and -) loop wires should be twisted pair and installed in separate grounded conduit or shielded cable to protect the loop from extraneous electrical interference. If a cable shield is provided, the shield connection to and from the detector must be continuous by using wire nuts, crimping, or soldering as appropriate for a reliable connection.

Wire connections are made by stripping about 3/8" of insulation from the end of the wire (use strip gauge molded in base), sliding the bare end of the wire under the clamping plate, and tightening the clamping plate screw. Do not loop the wire under the clamping plate.

**Figure 3. Class A or Class B wiring diagram for model 2412AT and 2424AT detectors used with four-wire control panels:**

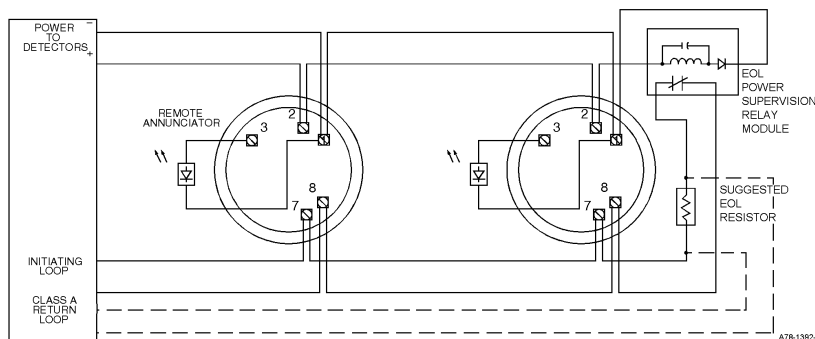

A78-1392-0

**Figure 4. Additional wiring needed for the isolated thermal unit of the 2424AIT detector thermal units are wired to a separate loop:**

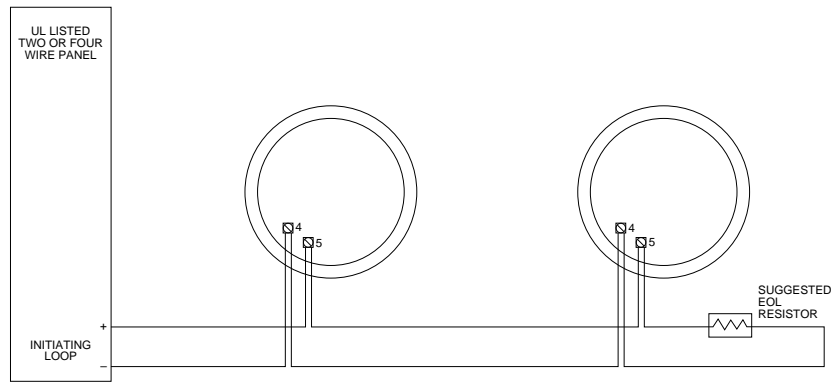

A78-1392-01

**CAUTION**

Dust covers are an effective way to limit the entry of dust into smoke detector sensing chambers. However, they may not completely prevent airborne dust particles from entering the detector. Therefore, System Sensor recommends the removal of detectors before beginning construction or other dust producing activity. Be sure to remove dust covers from any sensors that were left in place during construction as part of returning the system to service.

**TESTING**

**NOTE:** Before testing, notify the proper authorities that the smoke detector system is undergoing maintenance, and therefore will temporarily be out of service. Disable the zone or system undergoing maintenance to prevent unwanted alarms.

Detectors must be tested after installation and periodic maintenance. The 2412AT, 2424AT or 2424AIT may be tested in the following ways:

**NOTE:** Before testing the detector check for the presence of the flashing LED. If it does not flash, power has been lost to the detector (check the wiring), or it is defective (return for repair, see Warranty information).

**A. Recessed Test Switch**

1. Push and hold the recessed test switch with a .1 inch maximum diameter tool.
2. The LED should latch within 5 seconds indicating alarm and annunciating the panel. The horn should also sound.

**B. Calibrated Test Card (System Sensor No. R59-18-00)**

1. Remove the detector cover by placing a small bladed screwdriver in the side slot of the detector cover, twisting it slightly until the cover can be turned counterclockwise for removal.
2. Insert the NO ALARM end of the test card fully into the test slot (see Figure 6) then slide it counterclockwise until it stops.

3. The detector should not alarm (wait at least 20 seconds).
4. Remove the test card by sliding it clockwise before removing, then repeat with the ALARM end of test card.
5. The LED should latch on within 20 seconds indicating alarm and annunciating the panel.
6. Put the cover back by gently rotating it clockwise until it locks in place.

**C. Test Module (System Sensor Model No. MOD400R)**

The MOD400R is used with an analog or digital voltmeter to check the detector sensitivity as described in the test module's manual.

**D. Aerosol Generator (GEMINI 501)**

Set the generator to represent 4%/ft. to 5%/ft. obscuration as described in the Gemini 501 manual. Using the bowl shaped applicator, apply aerosol until unit alarms.

**E. Direct Heat Method (Hair dryer of 1000-1500 watts)**

Direct the heat toward the bi-metallic collector. Hold the heat source about 12 inches from the detector in order to avoid damage to the plastic. When the heat rises to greater than 135°F, the detector should latch in alarm. The detector will reset only after it has had sufficient time to cool and the power source has been momentarily interrupted.

Notify the proper authorities that the system is back on line.

**Figure 5. Bottom and side views showing position of test switch:**

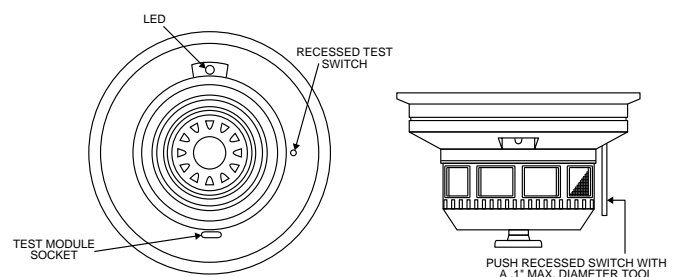

1410-00

Detectors that fail these tests should be cleaned as described under MAINTENANCE and retested. If the detectors still fail these tests they should be returned for repair.

## Maintenance

**NOTE:** Before cleaning, notify the proper authorities that the smoke detector system is undergoing maintenance, and will be temporarily out of service. Disable the system undergoing maintenance to prevent unwanted alarms.

1. Remove the detector cover by placing a small bladed screwdriver in the side slot of the detector cover, twisting it slightly until the cover can be turned counterclockwise for removal.
2. Vacuum the screen carefully without removing it. If further cleaning is required continue with Step 3, otherwise skip to Step 6.
3. Remove the screen by pulling it straight out. Vacuum the inside.
4. Clean the vaned chamber piece by vacuuming out dust and particles.
5. To replace the screen, orient it so that the arrow on top

aligns with the field test socket on the detector. Carefully push the screen into place, making sure it fits tightly to the chamber.

6. Replace the cover by gently rotating it clockwise until it locks in place.

**Figure 6:**

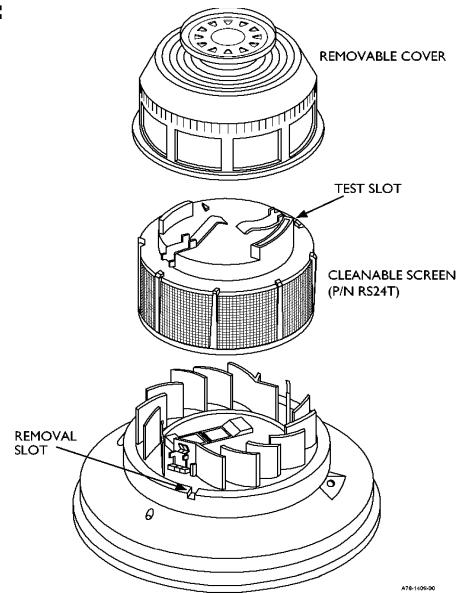

## WARNING

### The Limitations of Property Protection Smoke Detectors

Smoke detectors are designed to activate and initiate emergency action, but will do so only when used in conjunction with other equipment. These detectors are designed for installation in accordance with NFPA standard 72.

**Smoke detectors will not work without power.** AC or DC powered smoke detectors will not work if the power supply is cut off for any reason.

**Smoke detectors will not sense fires which start where smoke does not reach the detectors.** Smoke from fires in chimneys, in walls, on roofs, or on the other side of closed doors may not reach the smoke detector and alarm it.

**A detector may not detect a fire developing on another level of a building.** For this reason, detectors should be located on every level of a building.

**Smoke detectors have sensing limitations, too.** Ionization detectors offer broad range fire-sensing capability, but they are better at detecting

fast, flaming fires than slow, smoldering fires. Photoelectronic detectors sense smoldering fires better than flaming fires. Because fires develop in different ways, and are often unpredictable in their growth, neither type of detector is always best, and a given detector may not always provide warning of a fire. In general, detectors cannot be expected to provide warnings for fires resulting from inadequate fire protection practices, violent explosions, escaping gas, improper storage of flammable liquids like cleaning solvents, other safety hazards, or arson. Smoke detectors used in high air velocity conditions may fail to alarm due to dilution of smoke densities created by such frequent and rapid air exchanges. Additionally, high air velocity environments may create increased dust contamination, demanding more frequent maintenance.

**Smoke detectors cannot last forever.** Smoke detectors contain electronic parts. Even though detectors are made to last over 10 years, any of these parts could fail at any time. Therefore, test your smoke detector system per NFPA 72E at least semiannually. Clean and take care of your smoke detectors regularly. Taking care of the fire detection system you have installed will measurably reduce your product liability risks.

### Three-Year Limited Warranty

System Sensor warrants its enclosed smoke detector to be free from defects in materials and workmanship under normal use and service for a period of three years from date of manufacture. System Sensor makes no other express warranty for this smoke detector. No agent, representative, dealer, or employee of the Company has the authority to increase or alter the obligations or limitations of this Warranty. The Company's obligation of this Warranty shall be limited to the repair or replacement of any part of the smoke detector which is found to be defective in materials or workmanship under normal use and service during the three year period commencing with the date of manufacture. After phoning System Sensor's toll free number 800-SENSOR2 (736-7672) for a Return Authorization number, send defective units postage prepaid to: System Sensor, Repair Depart-

ment, RA # \_\_\_\_\_, 3825 Ohio Avenue, St. Charles, IL 60174. Please include a note describing the malfunction and suspected cause of failure. The Company shall not be obligated to repair or replace units which are found to be defective because of damage, unreasonable use, modifications, or alterations occurring after the date of manufacture. In no case shall the Company be liable for any consequential or incidental damages for breach of this or any other Warranty, expressed or implied whatsoever, even if the loss or damage is caused by the Company's negligence or fault. Some states do not allow the exclusion or limitation of incidental or consequential damages, so the above limitation or exclusion may not apply to you. This Warranty gives you specific legal rights, and you may also have other rights which vary from state to state.