

REV	DESCRIPTION	BY DATE	APPD
A	RELEASED PER ECR 7401	JED 7/15/02	[Signature]

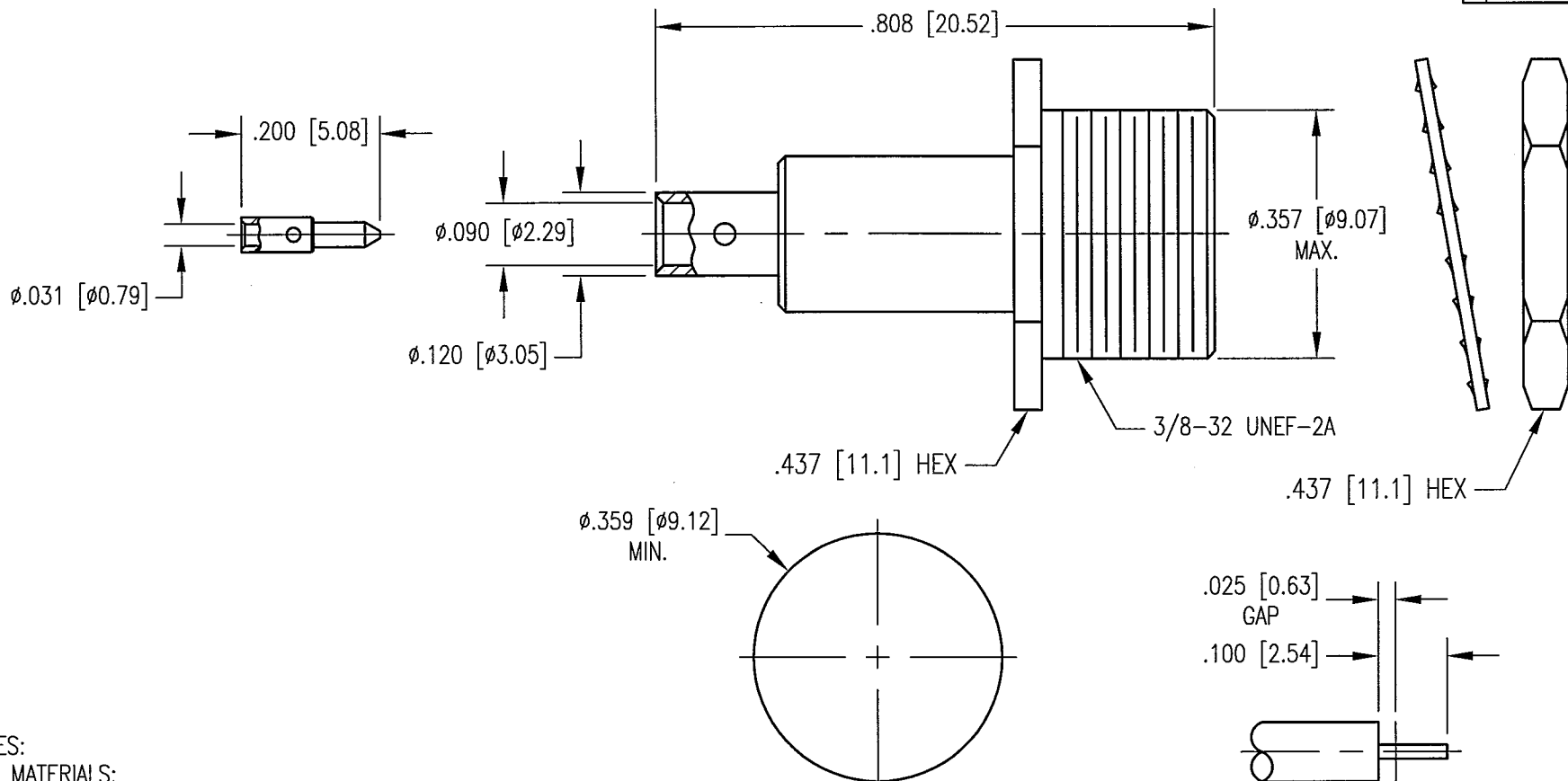

RECOMMENDED MOUNTING HOLE

CABLE TRIMMING DIMENSIONS

NOTES:

- MATERIALS:
 CENTER CONTACT: COPPER ALLOY
 LOCKWASHER: PHOSPHOR BRONZE PER ASTM B103
 ALL OTHER METAL PARTS: BRASS PER ASTM B16
 INSULATOR: TEFLON PER ASTM D1710
- FINISH:
 CONTACTS AND SHROUD: .000030 MIN. GOLD PER MIL-G-45204 OVER
 .000050 MIN. NICKEL PER QQ-N-290
 BODY: .000015 MIN. GOLD PER MIL-G-45204 OVER
 .000050 MIN. NICKEL PER QQ-N-290
 ALL OTHER METAL PARTS: .000005 MIN. GOLD PER MIL-G-45204 OVER
 .000050 MIN. NICKEL PER QQ-N-290
- FOR USE WITH .085 DIA. SEMI-RIGID CABLE OR EQUIVALENT.
- FOR CABLING PROCEDURES USE CAP 5-24 WITH TRIMMING DIMENSIONS SHOWN.

PER ASME Y14.5M-1994 UNLESS OTHERWISE SPECIFIED: DIMENSIONS ARE IN INCHES [MM] TOLERANCES: DECIMALS .XX ± .01 [0.254] .XXX ± .005 [0.127] ANGLES ± 2° SCALE: 4:1		NORTHROP GRUMMAN Winchester Electronics 400 Park Road Watertown, CT 06795	
CUSTOMER DRAWING		TITLE BMA STRAIGHT BULKHEAD JACK	
DRAWN JED	DATE 7/15/02	CHECKED [Signature]	DATE 7-18-02
APPROVED [Signature]	DATE 7/18/02	APPROVED [Signature]	DATE 7/18/02
A		361-595-0850H	SHT. OF REV. 1 1 A