

molex® **2.00mm (.079") Pitch**
MZP™ Hard Metric
Board-to-Board
PCB Plug

55357/55376
Type B, Vertical

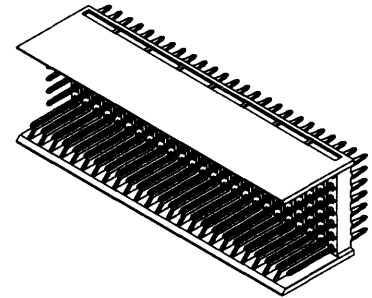

Backplane Connector Systems



FEATURES AND SPECIFICATIONS

Features and Benefits

- 125 Circuits—5 rows by 25 columns
- 175 Circuits—7 rows by 25 columns
- M style press-fit pin contact design creates four points of contact for a gas-tight connection
- Internal guide ribs to accommodate shield grounding points

Reference Information

Product Specification: PS-55357-011
 Packaging: Tube
 UL File No.: E29179 (only 55376)
 CSA File No.: LR19980 (only 55376)
 Mates With: 54457 and 54491 Type B receptacles
 Designed In: Millimeters

Electrical

Voltage: 500V
 Current: 1.0A
 Contact Resistance: 30 milliohms max.
 Dielectric Withstanding Voltage: 750V AC/1 min.
 Insulation Resistance: 10,000 Megohms min.

Physical

Housing: Gray glass-filled PBT, UL 94V-0
 Contact: Phosphor Bronze
 Plating: 0.8µm (31µ") min. Gold over Nickel
 Operating Temperature: -55 to +125°C

CATALOG DRAWING (FOR REFERENCE ONLY)

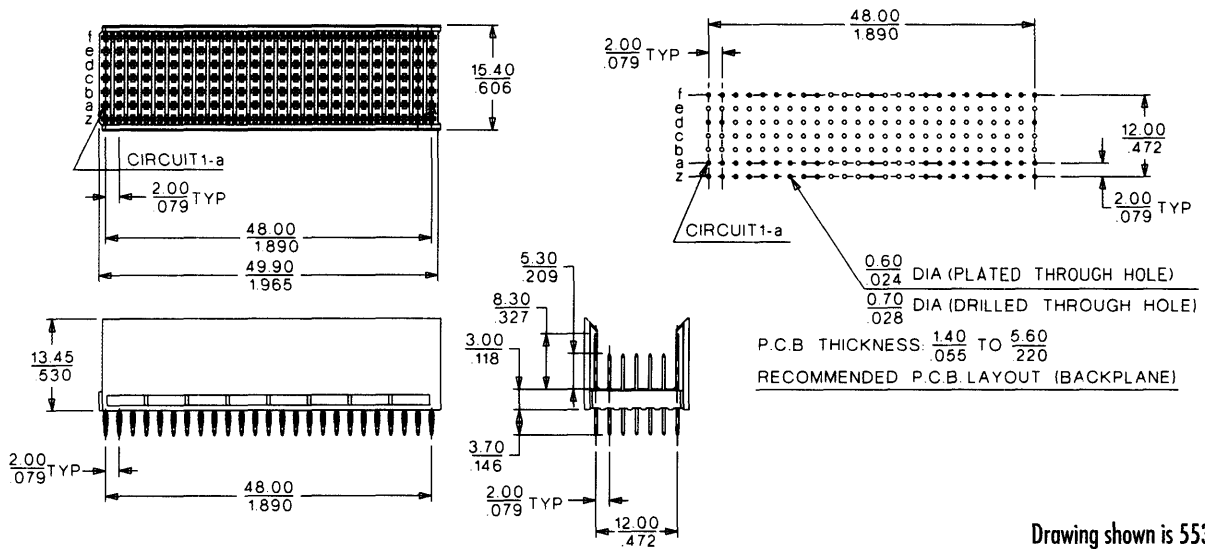

Drawing shown is 55376-1759

Note: See next page for additional ordering details.

molex® 2.00mm (.079") Pitch
MZP™ Hard Metric
Board-to-Board
Sequence Chart
PCB Plug, Type B

Backplane Connector Systems

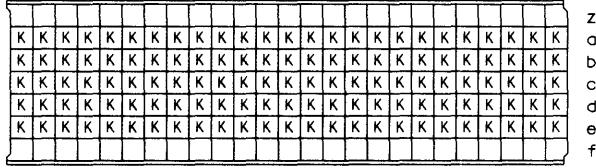

25 24 23 22 21 20 19 18 17 16 15 14 13 12 11 10 9 8 7 6 5 4 3 2 1

| | |
|-----------------|------------------|
| Circuits | Order No. |
| 125 | 55357-1259 |

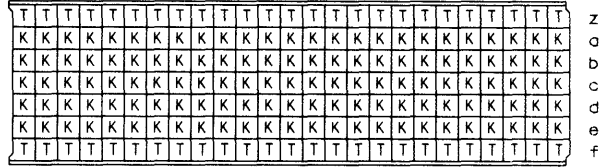

25 24 23 22 21 20 19 18 17 16 15 14 13 12 11 10 9 8 7 6 5 4 3 2 1

| | |
|-----------------|------------------|
| Circuits | Order No. |
| 175 | 55357-1759 |

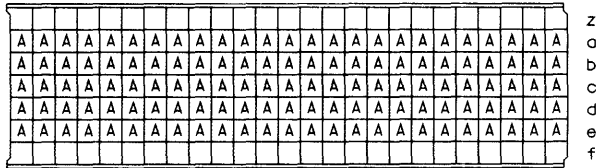

25 24 23 22 21 20 19 18 17 16 15 14 13 12 11 10 9 8 7 6 5 4 3 2 1

| | |
|-----------------|------------------|
| Circuits | Order No. |
| 125 | 55376-1259 |

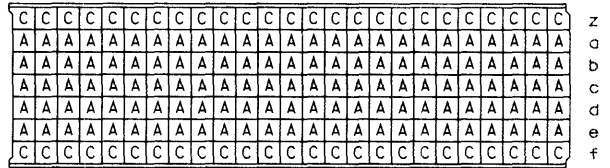

25 24 23 22 21 20 19 18 17 16 15 14 13 12 11 10 9 8 7 6 5 4 3 2 1

| | |
|-----------------|------------------|
| Circuits | Order No. |
| 175 | 55376-1759 |

PIN VARIATION

