

500 WATT ULTRA LOW CAPACITANCE STEERING DIODE/TVS ARRAY

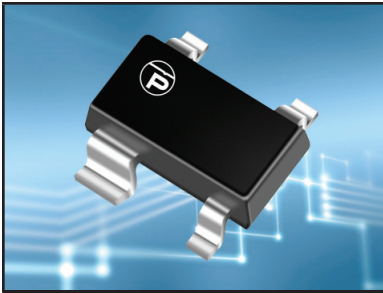

SOT-143 PACKAGE

DESCRIPTION

The PSR05LC is an ultra low capacitance steering diode TVS array, designed to protect two I/O lines from the effects of Electrostatic Discharge (ESD) and Electrical Fast Transients (EFT). The PSR05 provides ESD protection up to 25 kilovolts. The PSR05LC has a peak pulse power rating of 500 Watts for an 8/20 μ s waveshape.

The low capacitance of the steering diode allows the designer to protect high speed data applications. The small SOT-143 package, with four leads reduces the internal lead inductance for low overshoot voltage during fast front time transient events, such as ESD. The PSR05LC meets the IEC 61000-4-2 and IEC 61000-4-4 requirements.

FEATURES

- Compatible with IEC 61000-4-2 (ESD): Air - 15kV, Contact - 8kV
- Compatible with IEC 61000-4-4 (EFT): 40A - 5/50ns
- Compatible with IEC 61000-4-5 (Surge): 24A, 8/20 μ s - Level 2 (Line-Gnd) & Level 3 (Line-Line)
- Low Clamping Voltage
- Unidirectional Configuration
- 500 Watts Peak Pulse Power per Line ($t_p = 8/20\mu s$)
- Protects Two I/O Ports & Power Supply
- Ultra Low Capacitance: 2.5pF Typical - $C_{j(SD)}$
- RoHS Compliant
- REACH Compliant

APPLICATIONS

- Ethernet - 10/100/1000 Base T
- USB
- Wireless Communications
- FireWire

MECHANICAL CHARACTERISTICS

- Molded JEDEC SOT-143 Package
- Approximate Weight: 9 milligrams
- Lead-Free Pure-Tin Plating (Annealed)
- Solder Reflow Temperature:
Pure-Tin - Sn, 100: 260-270°C
- 8mm Tape and Reel Per EIA Standard 481
- Flammability Rating UL 94V-0

PIN CONFIGURATION

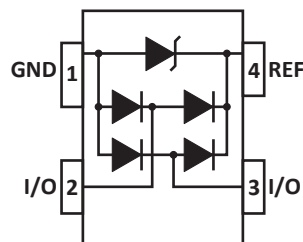

TYPICAL DEVICE CHARACTERISTICS
MAXIMUM RATINGS @ 25°C Unless Otherwise Specified

PARAMETER	SYMBOL	VALUE	UNITS
Operating Temperature	T_L	-55 to 150	°C
Storage Temperature	T_{STG}	-55 to 150	°C
Peak Pulse Power (tp = 8/20µs) - See Figure 1	P_{PP}	500	Watts
Peak Forward Voltage - $I_F = 1A, 8/20\mu s$	V_F	1.5	Volts

ELECTRICAL CHARACTERISTICS PER LINE @ 25°C Unless Otherwise Specified

PART NUMBER	DEVICE MARKING	RATED STAND-OFF VOLTAGE V_{WM} VOLTS	MINIMUM BREAKDOWN VOLTAGE @ 1mA $V_{(BR)}$ VOLTS	MAXIMUM CLAMPING VOLTAGE (Fig. 2) @ $I_p = 1A$ V_C VOLTS	MAXIMUM CLAMPING VOLTAGE (Fig. 2) @ 8/20µs $V_C @ I_{PP}$ VOLTS	MAXIMUM LEAKAGE CURRENT @ V_{WM} I_D µA	TYPICAL CAPACITANCE PER LINE 0V, 1MHz $C_{J(SD)}$ pF
PSR05LC	T5	5.0	6.0	9.8	20.0V @ 28.0A	5	2.5

TYPICAL DEVICE CHARACTERISTICS

FIGURE 1
PEAK PULSE POWER VS PULSE TIME

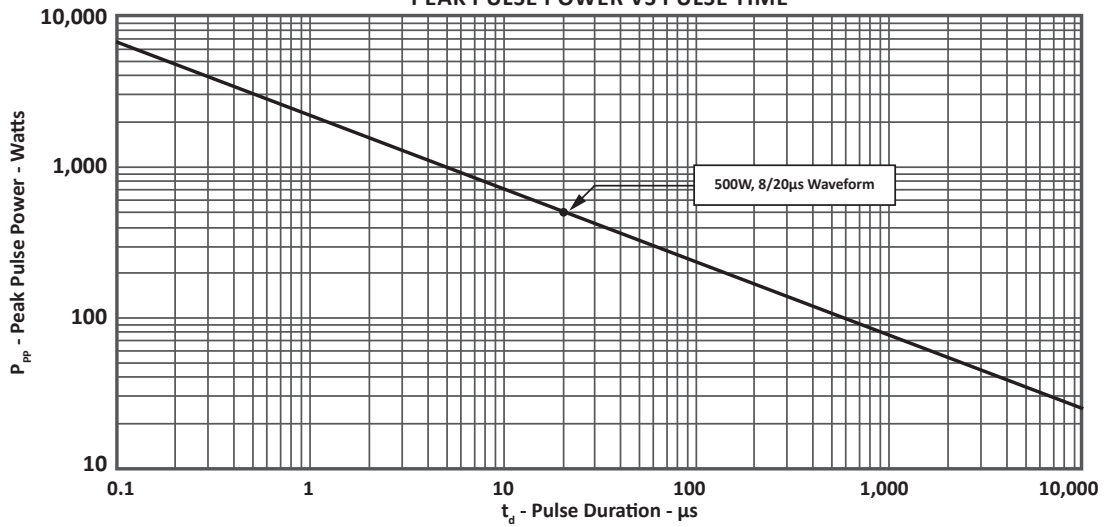

FIGURE 2
PULSE WAVE FORM

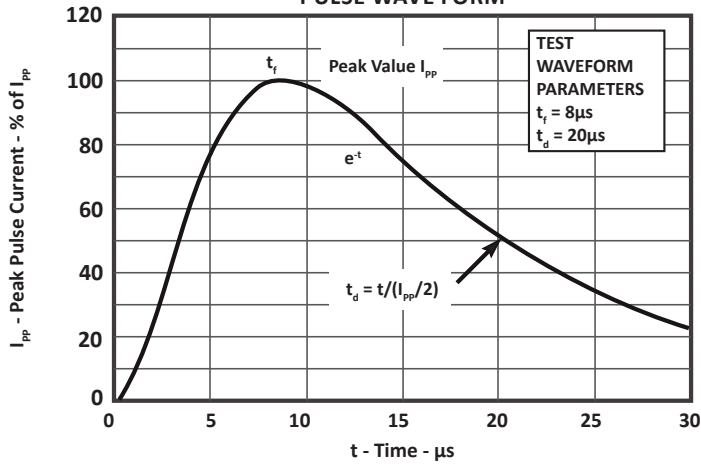
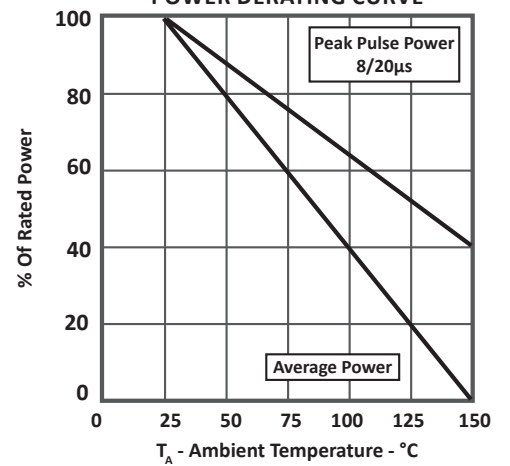
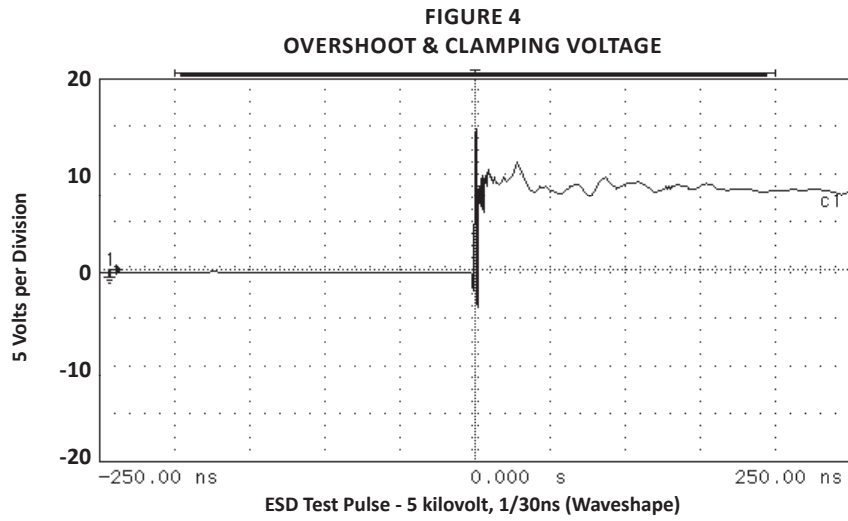

FIGURE 3
POWER DERATING CURVE



TYPICAL DEVICE CHARACTERISTICS



APPLICATION INFORMATION

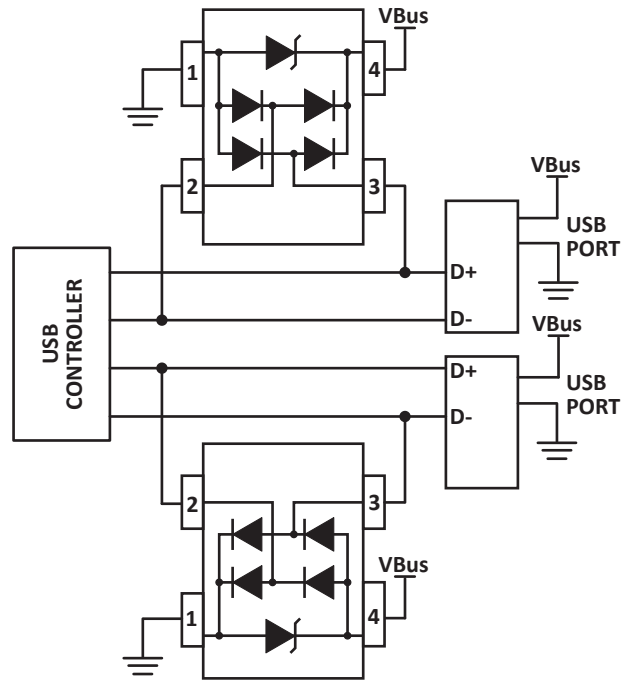

FIGURE 1 - USB PROTECTION

Two PSR05LCs in a Common-Mode configuration. Circuit connectivity is as follows:

- Pins 2 and 3 are connected to the datalines
- Pin 1 is connected to ground
- Pin 4 is connected to the databus

CIRCUIT BOARD RECOMMENDATIONS

Circuit board layout is critical for electromagnetic compatibility protection. The following guidelines are recommended:

- The protection device should be placed near the input terminals or connectors, the device will divert the transient current immediately before it can be coupled into the nearby traces.
- The path length between the TVS device and the protected line should be minimized.
- All conductive loops including power and ground loops should be minimized.
- The transient current return path to ground should be kept as short as possible to reduce parasitic inductance.
- Ground planes should be used whenever possible. For multilayer PCBs, use dedicated ground planes.

SOT-143 PACKAGE INFORMATION

OUTLINE DIMENSIONS

DIM	MILLIMETERS		INCHES	
	MIN	MAX	MIN	MAX
A	2.80	3.04	0.110	0.120
B	1.20	1.39	0.047	0.055
C	0.84	1.14	0.033	0.045
D	0.39	0.50	0.015	0.020
F	0.79	0.93	0.031	0.037
G	1.78	2.03	0.070	0.080
J	0.08	0.15	0.003	0.006
K	0.46	0.60	0.018	0.024
L	0.445	0.60	0.0175	0.024
L1	0.40	0.60	0.016	0.024
R	0.72	0.83	0.028	0.033
S	2.11	2.48	0.083	0.098

NOTES

1. Dimensioning and tolerances per ANSI Y14.M, 1985.
2. Controlling dimension: inches.
3. Dimensions are exclusive of mold flash and metal burrs.

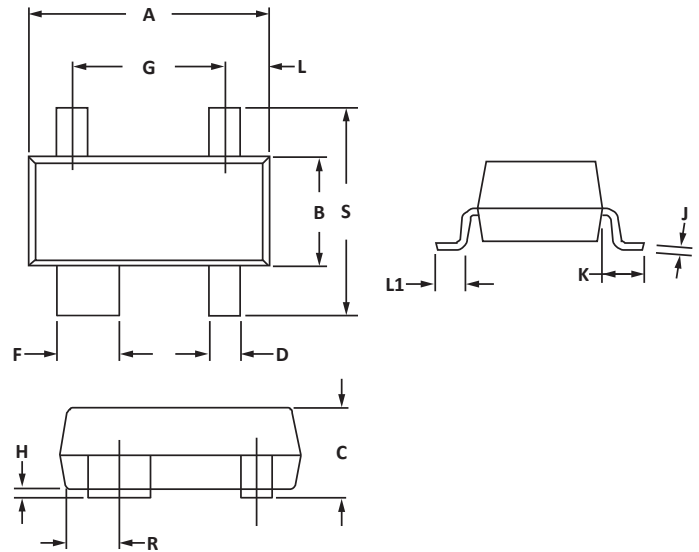

PAD LAYOUT DIMENSIONS

DIM	MILLIMETERS		INCHES	
	MIN	MAX	MIN	MAX
A	1.88	2.13	0.074	0.084
B	1.80	2.06	0.071	0.081
C	0.71	0.97	0.028	0.038
D	0.76	1.02	0.030	0.040
E	1.07	1.32	0.042	0.052
F	0.71	0.97	0.028	0.038

NOTES

1. Controlling dimension: inches.

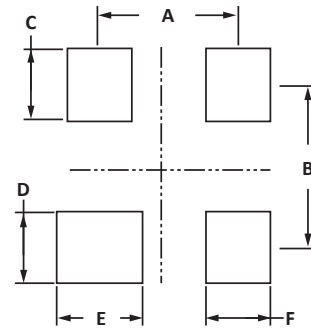

TAPE AND REEL

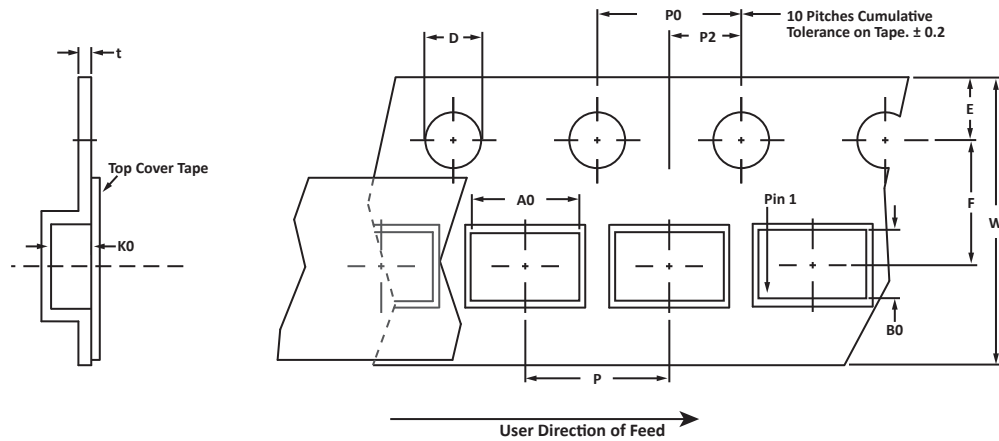

SPECIFICATIONS

REEL DIA.	TAPE WIDTH	A0	B0	K0	D	E	F	W	P0	P2	P	tmax
178mm (7")	8mm	3.10 ± 0.10	2.70 ± 0.10	1.35 ± 0.10	1.50 ± 0.10	1.75 ± 0.10	3.50 ± 0.05	8.00 ± 0.30	4.00 ± 0.10	2.00 ± 0.05	4.00 ± 0.10	0.25

NOTES

1. Dimensions are in millimeters.
2. Surface mount product is taped and reeled in accordance with EIA-481.
3. Suffix - T7 = 7" Reel - 3,000 pieces per 8mm tape.
4. Suffix - T13 = 13" Reel - 10,000 pieces per 8mm tape.
5. Marking on Part - marking code (see page 2) and date code.

Package outline, pad layout and tape specifications per document number 06011.R4 8/10.

ORDERING INFORMATION

BASE PART NUMBER	LEADFREE SUFFIX	TAPE SUFFIX	QTY/REEL	REEL SIZE	TUBE QTY
PSR05LC	n/a	-T7	3,000	7"	n/a
PSR05LC	n/a	-T13	10,000	13"	n/a

COMPANY INFORMATION

COMPANY PROFILE

ProTek Devices, based in Tempe, Arizona USA, is a manufacturer of Transient Voltage Suppression (TVS) products designed specifically for the protection of electronic systems from the effects of lightning, Electrostatic Discharge (ESD), Nuclear Electromagnetic Pulse (NEMP), inductive switching and EMI/RFI. With over 25 years of engineering and manufacturing experience, ProTek designs TVS devices that provide application specific protection solutions for all electronic equipment/systems.

ProTek Devices Analog Products Division, also manufactures analog interface, control, RF and power management products.

CONTACT US

Corporate Headquarters

2929 South Fair Lane
Tempe, Arizona 85282
USA

By Telephone

General: 602-431-8101
Sales: 602-414-5109
Customer Service: 602-414-5114

By Fax

General: 602-431-2288

By E-mail:

Sales: sales@protekdevices.com
Customer Service: service@protekdevices.com
Technical Support: support@protekdevices.com

Web

www.protekdevices.com
www.protekanalog.com

COPYRIGHT © ProTek Devices 2008 - This literature is subject to all applicable copyright laws and is not for resale in any manner.

SPECIFICATIONS: ProTek reserves the right to change the electrical and or mechanical characteristics described herein without notice.

DESIGN CHANGES: ProTek reserves the right to discontinue product lines without notice and that the final judgement concerning selection and specifications is the buyer's and that in furnishing engineering and technical assistance. ProTek assumes no responsibility with respect to the selection or specifications of such products. ProTek makes no warranty, representation or guarantee regarding the suitability of its products for any particular purpose, nor does ProTek assume any liability arising out of the application or use of any product or circuit and specifically disclaims any and all liability without limitation special, consequential or incidental damages.

LIFE SUPPORT POLICY: ProTek Devices products are not authorized for use in life support systems without written consent from the factory.