

FD177

Version : A.003
Issue Date : 2008/06/10
File Name : SP-FD177-A.003.doc
Total Pages : 8

*Single Coil Brushless DC Motor Drivers
with Soft-Switching
(2.0 to 6.5 Volts)*



SILICON TOUCH TECHNOLOGY INC.
新竹市科學園區展業一路九號七樓之一
9-7F-1 Prosperity Road I Science-Based Industrial Park
Hsinchu, Taiwan 300, R.O.C.
Tel : 886-3-5645656 Fax : 886-3-5645626

General Specifications

FD177 is a single coil DC brushless motor driver IC with soft-switching, locked protection, thermal shut down protection circuit, power polarity reverse protection and frequency generator. The driver is optimal for single coil fan applications with less external components.

Features and Benefits

- Support single-phase full wave Brushless DC Motor Driver
- Built-in Hall sensor input signal amplifier
- Low voltage startup (VDD=2.0V)
- High driving capability
- Lock detection and automatic self-restart
- Power polarity reverse protection
- Thermal shut down protection circuit
- Thin, compact, highly reliable package (TSOT-28)

Pin Description

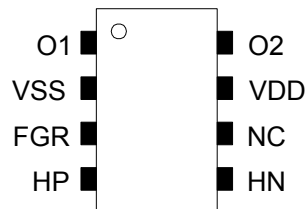

Package : TSOT-28

NO.	NAME	DESCRIPTION
1	O1	Output driving & sinking pin 1
2	VSS	Ground pin
3	FGR	Frequency generator
4	HP	Hall sensor in+
5	HN	Hall sensor in-
6	NC	None connection
7	VDD	Power supply pin
8	O2	Output driving & sinking pin 2



Absolute Maximum Ratings

(Unless otherwise noted, VDD=5V, T_A = 25 °C)

Characteristic	Symbol	Rating	Unit
Supply Voltage	V _{DDM}	6.5	V
Output Current	I _{OUT}	500	mA
Output Current at Locked (TSOT-28)	I _{OL1}	1	A
Maximum FGR Output Current	I _{FGR_MAX}	10	mA
Maximum FGR Output Voltage	V _{FGR_MAX}	6.5	V
Operating Temperature Range	T _{OPR}	-30 ~ 85	°C
Storage Temperature Range	T _{STG}	-65 ~ 150	°C
Power Dissipation (TSOT-28)	P _D	568	mW
Thermal Resistance, Junction to Ambient	θ _{JA_TSOT28}	220	°C/ W
Thermal Resistance, Junction to Case	θ _{JC_TSOT28}	92	°C/ W



Electrical Characteristics

(Unless otherwise noted, VDD=5V, T_A = 25 °C)

Characteristic	Sym.	Condition	Limit			Unit
			Min.	Typ.	Max.	
Operation Voltage	V _{DD}		2	5	6.5	V
Supply current	I _{CC}			3	5	mA
Maximum Output Voltage Range	V _{OH}	I _{OUT} = 300 mA	4.5	4.65	-	V
Minimum Output Voltage Range	V _{OL}	I _{OUT} = 300 mA	-	0.35	0.5	V
FG Output Low Voltage	V _{FGROL}	I _{FGR} = 3 mA	-	0.25	0.4	V
Hall Amplifier Offset	V _{Offset}		-9	0	9	mV
Input-Output Gain	G _{IO}		45	48	51	dB
Automatic self-restart						
Lock detection on Time	T _{ON}	-	110	150	190	ms
Lock detection off Time	T _{OFF}	-	0.75	1.05	1.35	Sec

Application Circuit

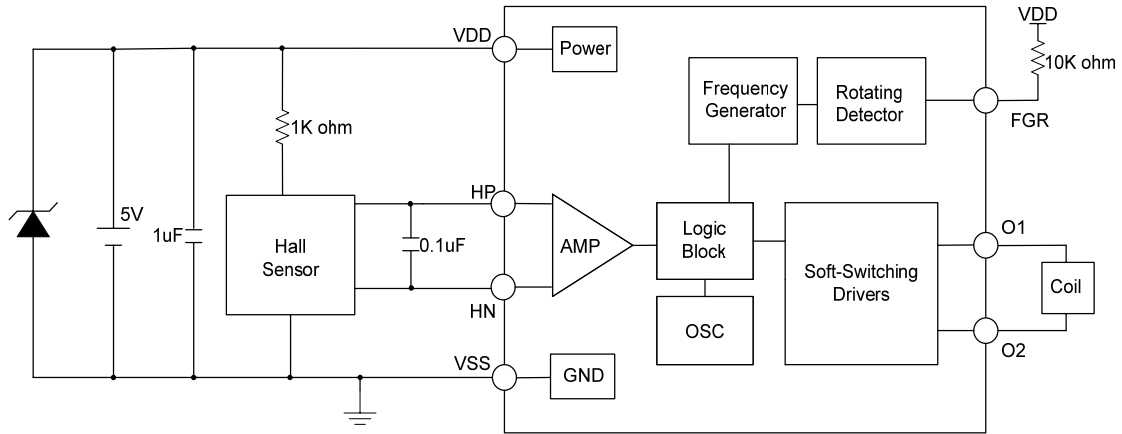

Output Waveform

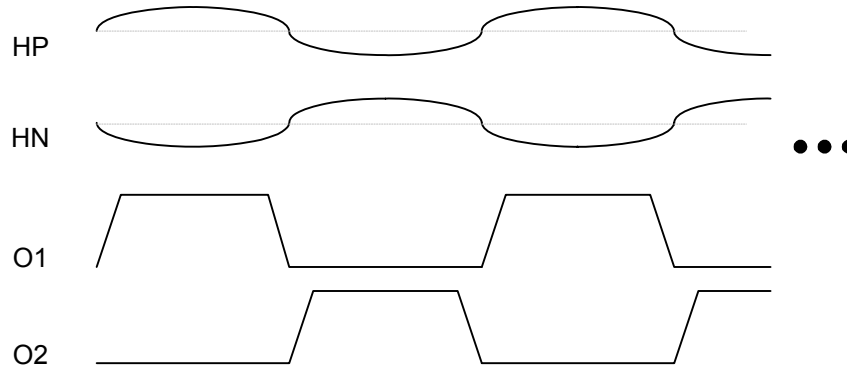

Truth Table

Hall input	O1	O2
HP > HN	H	L
HP < HN	L	H

Application Notes

- The device is operated within wide supply voltage range from 2.0 to 6.5 Volts. The design, specifications and performance have been optimized for 5V brushless DC motor applications.
- The output driver node O1/O2 will be “turned to drive/sink” when $V(HP) > V(HN)$. Similarly, the output O1/O2 will be “turned to sink/drive” when $V(HP) < V(HN)$.
- There is no need of external timing capacitor for lock protection and auto-restart function. For 5V application, the drivers will be shut down roughly 1 second after the motor is locked. When the drivers have been shut down, the automatic self-restart circuit will try to power up the drivers every 1 second until lock is released.
- There is no requirement of protection diode for power reverse fault in normal applications. The power polarity reverse protection circuit is built-in.
- The connection of the capacitor 1uF between VDD and GND and the capacitor 0.1uF between Hall sensor HP and HN will increase the system stability when motor is rotating.
- The power dissipated by the IC varies widely with the supply voltage, the output current, and loading. It is important to ensure the application does not exceed the allowable power dissipation of the IC package. The recommended motor driver power dissipation versus temperature is depicted as follows:

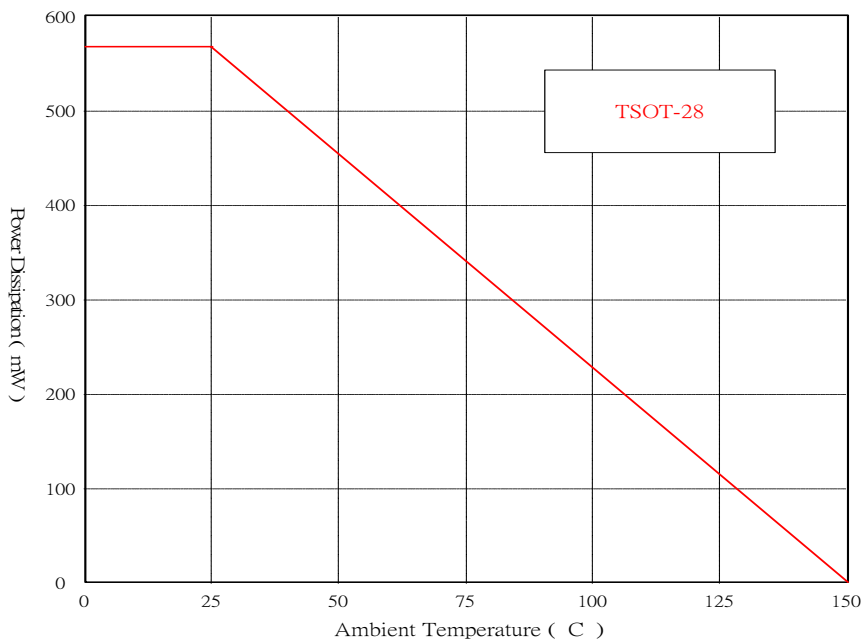

□

Package Specifications
FD177 : TSOT-28

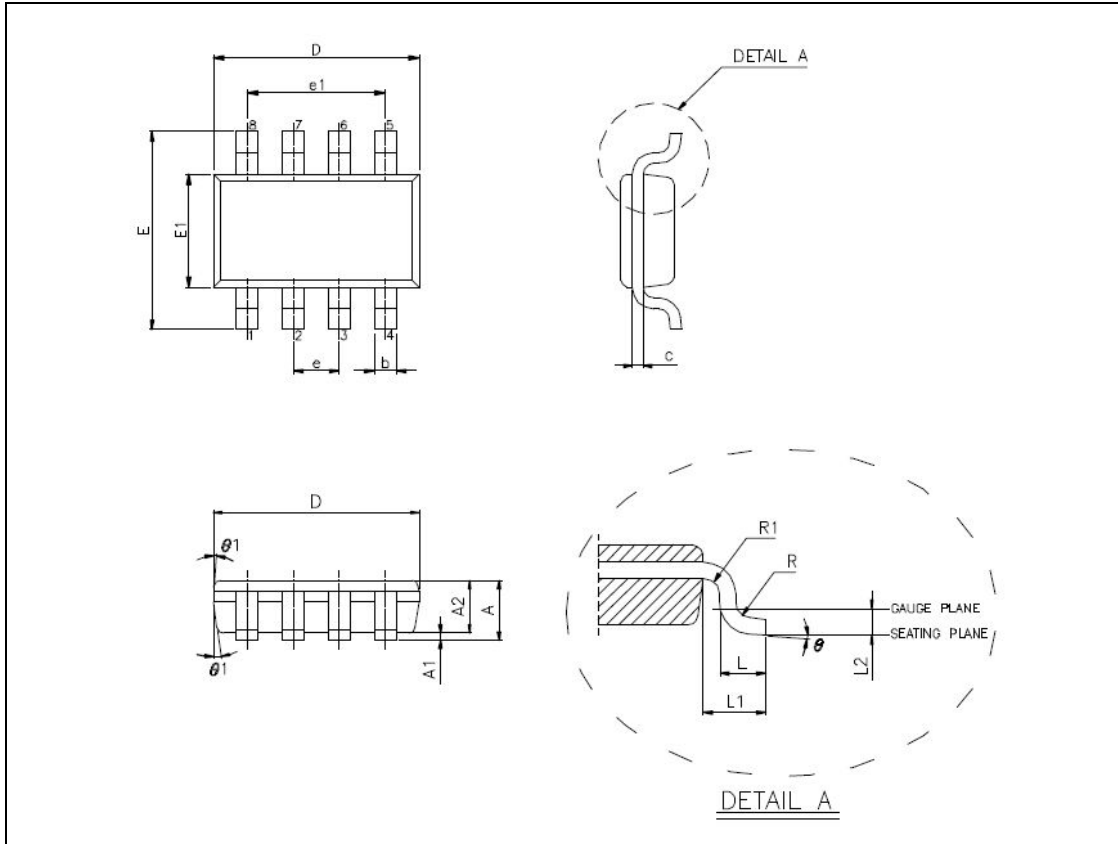

VARIATION(ALL DIMENSIONS SHOWN IN MM)

SYMBOL	MIN.	NOM.	MAX.
A	0.750	-	0.800
A1	0	-	0.050
A2	0.700	0.750	0.775
b	0.220	-	0.380
c	0.100	-	0.200
D	2.800	2.900	3.000
E	2.600	2.800	3.000
E1	1.500	1.600	1.700
e	0.650 BSC		
e1	1.950 BSC		
L	0.370	0.450	0.600
L1	0.600 REF		
L2	0.250 BSC		
R	0.100	-	-
R1	0.100	-	0.250
θ	0°	4°	8°
θ 1	4°	10°	12°



The products listed herein are designed for ordinary electronic applications, such as electrical appliances, audio-visual equipment, communications devices and so on. Hence, it is advisable that the devices should not be used in medical instruments, surgical implants, aerospace machinery, nuclear power control systems, disaster/crime-prevention equipment and the like. Misusing those products may directly or indirectly endanger human life, or cause injury and property loss.

Silicon Touch Technology, Inc. will not take any responsibilities regarding the misuse of the products mentioned above. Anyone who purchases any products described herein with the above-mentioned intention or with such misused applications should accept full responsibility and indemnify. Silicon Touch Technology, Inc. and its distributors and all their officers and employees shall defend jointly and severally against any and all claims and litigation and all damages, cost and expenses associated with such intention and manipulation.