

MC9S12A128

Device Guide

V01.01

Original Release Date: 8 March, 2002
Revised: 17 April, 2002

Motorola, Inc

Motorola reserves the right to make changes without further notice to any products herein to improve reliability, function or design. Motorola does not assume any liability arising out of the application or use of any product or circuit described herein; neither does it convey any license under its patent rights nor the rights of others. Motorola products are not designed, intended, or authorized for use as components in systems intended for surgical implant into the body, or other applications intended to support or sustain life, or for any other application in which the failure of the Motorola product could create a situation where personal injury or death may occur. Should Buyer purchase or use Motorola products for any such unintended or unauthorized application, Buyer shall indemnify and hold Motorola and its officers, employees, subsidiaries, affiliates, and distributors harmless against all claims, costs, damages, and expenses, and reasonable attorney fees arising out of, directly or indirectly, any claim of personal injury or death associated with such unintended or unauthorized use, even if such claim alleges that Motorola was negligent regarding the design or manufacture of the part.

Revision History

Version Number	Revision Date	Effective Date	Author	Description of Changes
V01.00	8 MAR 2002	8 MAR 2002		Initial release
V01.01	17 APRIL 2002	12 APRIL 2002		Replaced document order number with version except for cover sheet
				Corrected Table 1-1 Device Memory Map entries for EEPROM array and RAM array
				Table A-4 Operating Conditions — Increased V_{DD} to 2.35V
				Table A-6 5V I/O Characteristics — Corrected rating column for V_{OH} and V_{OL} and typical value for C_{in}
				Table A-8 ATD Operating Characteristics — Updated rating definitions for items 6, 7, and 8 for clarity

For additional information, refer to the MC9S12A128 8-Bit Microcontroller Unit Mask Set Errata (Motorola document order number, 9S12A128MSE1). The errata can be found on the World Wide Web at:

<http://www.motorola.com/semiconductors/>

Table of Contents

Section 1 Introduction

1.1	Overview	15
1.2	Features	15
1.3	Modes of Operation	17
1.4	Block Diagram	18
1.5	Device Memory Map	20
1.6	Part ID Assignments	22

Section 2 Signal Description

2.1	Device Pinout	23
2.2	Signal Properties Summary	26
2.3	Detailed Signal Descriptions	28
2.3.1	EXTAL, XTAL — Oscillator Pins	28
2.3.2	$\overline{\text{RESET}}$ — External Reset Pin	28
2.3.3	TEST — Test Pin	28
2.3.4	V_{REGEN} — Voltage Regulator Enable Pin	28
2.3.5	XFC — PLL Loop Filter Pin	28
2.3.6	BKGD / $\overline{\text{TAGHI}}$ / MODC — Background Debug, Tag High, and Mode Pin	29
2.3.7	PAD15 / AN15 / ETRIG1 — Port AD Input Pin of ATD1	29
2.3.8	PAD[14:08] / AN[14:08] — Port AD Input Pins of ATD1	29
2.3.9	PAD7 / AN07 / ETRIG0 — Port AD Input Pin of ATD0	29
2.3.10	PAD[06:00] / AN[06:00] — Port AD Input Pins of ATD0	29
2.3.11	PA[7:0] / ADDR[15:8] / DATA[15:8] — Port A I/O Pins	29
2.3.12	PB[7:0] / ADDR[7:0] / DATA[7:0] — Port B I/O Pins	29
2.3.13	PE7 / NOACC / $\overline{\text{XCLKS}}$ — Port E I/O Pin 7	29
2.3.14	PE6 / MODB / IPIPE1 — Port E I/O Pin 6	30
2.3.15	PE5 / MODA / IPIPE0 — Port E I/O Pin 5	30
2.3.16	PE4 / ECLK — Port E I/O Pin 4	30
2.3.17	PE3 / $\overline{\text{LSTRB}}$ / $\overline{\text{TAGLO}}$ — Port E I/O Pin 3	30
2.3.18	PE2 / $\overline{\text{R/W}}$ — Port E I/O Pin 2	30
2.3.19	PE1 / $\overline{\text{IRQ}}$ — Port E Input Pin 1	30
2.3.20	PE0 / $\overline{\text{XIRQ}}$ — Port E Input Pin 0	30
2.3.21	PH7 / KWH7 — Port H I/O Pin 7	31

2.3.22	PH6 / KWH6 — Port H I/O Pin 6	31
2.3.23	PH5 / KWH5 — Port H I/O Pin 5	31
2.3.24	PH4 / KWH4 — Port H I/O Pin 4	31
2.3.25	PH3 / KWH3 / $\overline{SS1}$ — Port H I/O Pin 3	31
2.3.26	PH2 / KWH2 / SCK1 — Port H I/O Pin 2	31
2.3.27	PH1 / KWH1 / MOSI1 — Port H I/O Pin 1	31
2.3.28	PH0 / KWH0 / MISO1 — Port H I/O Pin 0	31
2.3.29	PJ7 / KWJ7 / SCL — PORT J I/O Pin 7	32
2.3.30	PJ6 / KWJ6 / SDA — PORT J I/O Pin 6	32
2.3.31	PJ[1:0] / KWJ[1:0] — Port J I/O Pins [1:0]	32
2.3.32	PK7 / \overline{ECS} / ROMON — Port K I/O Pin 7	32
2.3.33	PK[5:0] / XADDR[19:14] — Port K I/O Pins [5:0]	32
2.3.34	PM7 — Port M I/O Pin 7	32
2.3.35	PM6 — Port M I/O Pin 6	32
2.3.36	PM5 / SCK0 — Port M I/O Pin 5	32
2.3.37	PM4 / MOSI0 — Port M I/O Pin 4	32
2.3.38	PM3 / $\overline{SS0}$ — Port M I/O Pin 3	33
2.3.39	PM2 / MISO0 — Port M I/O Pin 2	33
2.3.40	PM1 — Port M I/O Pin 1	33
2.3.41	PM0 — Port M I/O Pin 0	33
2.3.42	PP7 / KWP7 / PWM7 — Port P I/O Pin 7	33
2.3.43	PP6 / KWP6 / PWM6 — Port P I/O Pin 6	33
2.3.44	PP5 / KWP5 / PWM5 — Port P I/O Pin 5	33
2.3.45	PP4 / KWP4 / PWM4 — Port P I/O Pin 4	33
2.3.46	PP3 / KWP3 / PWM3 / SS1 — Port P I/O Pin 3	33
2.3.47	PP2 / KWP2 / PWM2 / SCK1 — Port P I/O Pin 2	34
2.3.48	PP1 / KWP1 / PWM1 / MOSI1 — Port P I/O Pin 1	34
2.3.49	PP0 / KWP0 / PWM0 / MISO1 — Port P I/O Pin 0	34
2.3.50	PS7 / $\overline{SS0}$ — Port S I/O Pin 7	34
2.3.51	PS6 / SCK0 — Port S I/O Pin 6	34
2.3.52	PS5 / MOSI0 — Port S I/O Pin 5	34
2.3.53	PS4 / MISO0 — Port S I/O Pin 4	34
2.3.54	PS3 / TXD1 — Port S I/O Pin 3	34
2.3.55	PS2 / RXD1 — Port S I/O Pin 2	35
2.3.56	PS1 / TXD0 — Port S I/O Pin 1	35
2.3.57	PS0 / RXD0 — Port S I/O Pin 0	35

2.3.58	PT[7:0] / IOC[7:0] — Port T I/O Pins [7:0]	35
2.4	Power Supply Pins	35
2.4.1	V _{DDX} , V _{SSX} — Power & Ground Pins for I/O Drivers	35
2.4.2	V _{DDR} , V _{SSR} — Power & Ground Pins for I/O Drivers & for Internal Voltage Regulator	35
2.4.3	V _{DD1} , V _{DD2} , V _{SS1} , V _{SS2} — Core Power Pins	36
2.4.4	V _{DDA} , V _{SSA} — Power Supply Pins for ATD and VREG	36
2.4.5	V _{RH} , V _{RL} — ATD Reference Voltage Input Pins	36
2.4.6	V _{DDPLL} , V _{SSPLL} — Power Supply Pins for PLL	36
2.4.7	V _{REGEN} — On Chip Voltage Regulator Enable	36

Section 3 System Clock Description

3.1	Overview	39
-----	----------	----

Section 4 Modes of Operation

4.1	Overview	41
4.2	Modes of Operation	41
4.2.1	Normal Operating Modes	42
4.2.2	Special Operating Modes	45
4.2.3	Test Operating Mode	45
4.3	Security	46
4.3.1	Securing the Microcontroller	46
4.3.2	Operation of the Secured Microcontroller	46
4.3.3	Unsecuring the Microcontroller	47
4.4	Low Power Modes	47

Section 5 Resets and Interrupts

5.1	Overview	49
5.2	Vectors	49
5.2.1	Vector Table	49
5.3	Effects of Reset	50
5.3.1	I/O Pins	50
5.3.2	Memory	50

Section 6 HCS12 Core Block Description

Section 7 Clock and Reset Generator (CRG) Block Description

7.1 Device-Specific Information51
7.1.1 \overline{XCLKS} 51

Section 8 Enhanced Capture Timer (ECT) Block Description

Section 9 Analog to Digital Converter (ATD) Block Description

Section 10 Inter-IC Bus (IIC) Block Description

Section 11 Serial Communications Interface (SCI) Block Description

Section 12 Serial Peripheral Interface (SPI) Block Description

Section 13 Pulse Width Modulator (PWM) Block Description

Section 14 Flash EEPROM 128K Block Description

Section 15 EEPROM 2K Block Description

Section 16 RAM Block Description

Section 17 Port Integration Module (PIM) Block Description

Section 18 Voltage Regulator (V_{REG}) Block Description

Appendix A Electrical Characteristics

A.1 General57
A.1.1 Parameter Classification57
A.1.2 Power Supply57
A.1.3 Pins58
A.1.4 Current Injection59
A.1.5 Absolute Maximum Ratings59
A.1.6 ESD Protection and Latch-up Immunity60
A.1.7 Operating Conditions61
A.1.8 Power Dissipation and Thermal Characteristics62
A.1.9 I/O Characteristics64
A.1.10 Supply Currents65

A.2	ATD Characteristics	66
A.2.1	ATD Operating Characteristics	66
A.2.2	Factors Influencing accuracy	66
A.2.3	ATD Accuracy	68
A.3	NVM, Flash, and EEPROM	70
A.3.1	NVM Timing	70
A.3.2	NVM Reliability	72
A.4	Voltage Regulator	73
A.5	Reset, Oscillator and PLL	74
A.5.1	Startup	74
A.5.2	Oscillator	75
A.5.3	Phase Locked Loop	76
A.6	SPI	80
A.6.1	Master Mode	80
A.6.2	Slave Mode	81
A.7	External Bus Timing	83
A.7.1	General Muxed Bus Timing	83

Appendix B Package Information

B.1	General	87
B.2	112-Pin LQFP Package	88
B.3	80-Pin QFP Package	89

List of Figures

Figure 1-1	MC9S12A128 Block Diagram	19
Figure 1-2	MC9S12A128 Memory Map	21
Figure 2-1	Pin Assignments in 112-Pin LQFP	24
Figure 2-2	Pin Assignments in 80-Pin QFP for MC9S12A128	25
Figure 2-3	PLL Loop Filter Connections	28
Figure 3-1	Clock Connections	39
Figure 18-1	Recommended PCB Layout 112 LQFP	55
Figure 18-2	Recommended PCB Layout for 80 QFP	56
Figure A-1	ATD Accuracy Definitions	69
Figure A-2	Basic PLL Functional Diagram	76
Figure A-3	Jitter Definitions	78
Figure A-4	Maximum Bus Clock Jitter Approximation	78
Figure A-5	SPI Master Timing (CPHA = 0)	80
Figure A-6	SPI Master Timing (CPHA =1)	80
Figure A-7	SPI Slave Timing (CPHA = 0)	81
Figure A-8	SPI Slave Timing (CPHA =1)	82
Figure A-9	General External Bus Timing	84
Figure B-1	112-Pin LQFP Mechanical Dimensions (Case no. 987)	88
Figure B-2	80-pin QFP Mechanical Dimensions (Case no. 841B)	89

List of Tables

Table 0-1	Document References	13
Table 1-1	Device Memory Map	20
Table 1-2	Assigned Part ID Numbers	22
Table 1-3	Memory Size Registers	22
Table 2-1	Signal Properties	26
Table 2-2	MC9S12A128 Power and Ground Connection Summary	37
Table 4-1	Mode Selection	41
Table 5-1	Interrupt Vector Locations	49
Table A-1	Absolute Maximum Ratings	59
Table A-2	ESD and Latch-up Test Conditions	60
Table A-3	ESD and Latch-Up Protection Characteristics	60
Table A-4	Operating Conditions	61
Table A-5	Thermal Package Characteristics	63
Table A-6	5V I/O Characteristics	64
Table A-7	Supply Current Characteristics	65
Table A-8	ATD Operating Characteristics	66
Table A-9	ATD Electrical Characteristics	67
Table A-10	ATD Conversion Performance	68
Table A-11	NVM Timing Characteristics	71
Table A-12	NVM Reliability Characteristics	72
Table A-13	Voltage Regulator Recommended Load Capacitances	73
Table A-14	Startup Characteristics	74
Table A-15	Oscillator Characteristics	75
Table A-16	PLL Characteristics	79
Table A-17	SPI Master Mode Timing Characteristics	81
Table A-18	SPI Slave Mode Timing Characteristics	82
Table A-19	Expanded Bus Timing Characteristics	85

Preface

The Device User Guide provides information about the MC9S12A128 device made up of standard HCS12 blocks and the HCS12 processor core.

This document is part of the customer documentation. A complete set of device manuals also includes the *CPU12 Reference Manual* (Motorola order number, CPU12RM/AD) and all the individual Block Guides of the implemented modules. In a effort to reduce redundancy all module specific information is located only in the respective Block Guide. If applicable, special implementation details of the module are given in the block description sections of this document.

See [Table 0-1](#) for names and versions of the referenced documents throughout the Device Guide.

Table 0-1 Document References

User Guide	Version	Document Order Number
HCS12 Core User Guide	V01	HCS12COREUG/D
CRG Block Guide	V03	S12CRGV3/D
ECT_16B8C Block Guide	V01	S12ECT16B8CV1/D
ATD_10B8C Block Guide	V02	S12ATD10B8CV2/D
IIC Block Guide	V02	S12IICV2/D
SCI Block Guide	V02	S12SCIV2/D
SPI Block Guide	V02	S12SPIV2/D
PWM_8B8C Block Guide	V01	S12PWM8B8CV1/D
FTS128K Block Guide	V02	S12FTS128KV1/D
EETS2K Block Guide	V02	S12EETS2KV1/D
VREG Block Guide	V01	S12VREGV1/D
PIM_9A128 Block Guide	V01	S12A128PIMV1/D

Section 1 Introduction

1.1 Overview

The MC9S12A128 microcontroller unit (MCU) is a 16-bit device composed of standard on-chip peripherals including a 16-bit central processing unit (HCS12 CPU), 128K bytes of Flash EEPROM, 8K bytes of RAM, 2K bytes of EEPROM, two asynchronous serial communications interfaces (SCI), two serial peripheral interfaces (SPI), an 8-channel IC/OC enhanced capture timer, two 8-channel, 10-bit analog-to-digital converters (ADC), an 8-channel pulse-width modulator (PWM), 29 discrete digital I/O channels (Port A, Port B, Port K and Port E), 20 discrete digital I/O lines with interrupt and wakeup capability and an Inter-IC Bus. System resource mapping, clock generation, interrupt control and bus interfacing are managed by the System Integration Module (SIM). The MC9S12A128 has full 16-bit data paths throughout. However, the external bus can operate in an 8-bit narrow mode so single 8-bit wide memory can be interfaced for lower cost systems. The inclusion of a PLL circuit allows power consumption and performance to be adjusted to suit operational requirements.

1.2 Features

- HCS12 Core
 - 16-bit HCS12 CPU
 - i. Upward compatible with M68HC11 instruction set
 - ii. Interrupt stacking and programmer's model identical to M68HC11
 - iii. Instruction queue
 - iv. Enhanced indexed addressing
 - MEBI (Multiplexed External Bus Interface)
 - MMC (Module Mapping Control)
 - INT (Interrupt control)
 - BKP (Breakpoints)
 - BDM (Background Debug Mode)
- CRG (low current oscillator, PLL, reset, clocks, COP watchdog, real time interrupt, clock monitor)
- 8-bit and 4-bit ports with interrupt functionality
 - Digital filtering
 - Programmable rising or falling edge trigger
- Memory
 - 128K Flash EEPROM
 - 2K byte EEPROM
 - 8K byte RAM

- Two 8-channel Analog-to-Digital Converters
 - 10-bit resolution
 - External conversion trigger capability
- Enhanced Capture Timer
 - 16-bit main counter with 7-bit prescaler
 - 8 programmable input capture or output compare channels
 - Two 8-bit or one 16-bit pulse accumulators
- 8 PWM channels
 - Programmable period and duty cycle
 - 8-bit 8-channel or 16-bit 4-channel
 - Separate control for each pulse width and duty cycle
 - Center-aligned or left-aligned outputs
 - Programmable clock select logic with a wide range of frequencies
 - Fast emergency shutdown input
 - Usable as interrupt inputs
- Serial interfaces
 - Two asynchronous Serial Communications Interfaces (SCI)
 - Two Synchronous Serial Peripheral Interface (SPI)
- Inter-IC Bus (IIC)
 - Compatible with I2C Bus standard
 - Multi-master operation
 - Software programmable for one of 256 different serial clock frequencies
- 112-Pin LQFP and 80-pin QFP packages
 - I/O lines with 5V input and drive capability
 - 5V A/D converter inputs
 - Operation at 50MHz equivalent to 25MHz Bus Speed
 - Development support
 - Single-wire background debug™ mode (BDM)
 - On-chip hardware breakpoints

1.3 Modes of Operation

User modes

- Normal and Emulation Operating Modes
 - Normal Single-Chip Mode
 - Normal Expanded Wide Mode
 - Normal Expanded Narrow Mode
 - Emulation Expanded Wide Mode
 - Emulation Expanded Narrow Mode
- Special Operating Modes
 - Special Single-Chip Mode with active Background Debug Mode
 - Special Test Mode (**Motorola use only**)
 - Special Peripheral Mode (**Motorola use only**)

Low power modes

- Stop Mode
- Pseudo Stop Mode
- Wait Mode

1.4 Block Diagram

Figure 1-1 shows a block diagram of the MC9S12A128 device.

Figure 1-1 MC9S12A128 Block Diagram

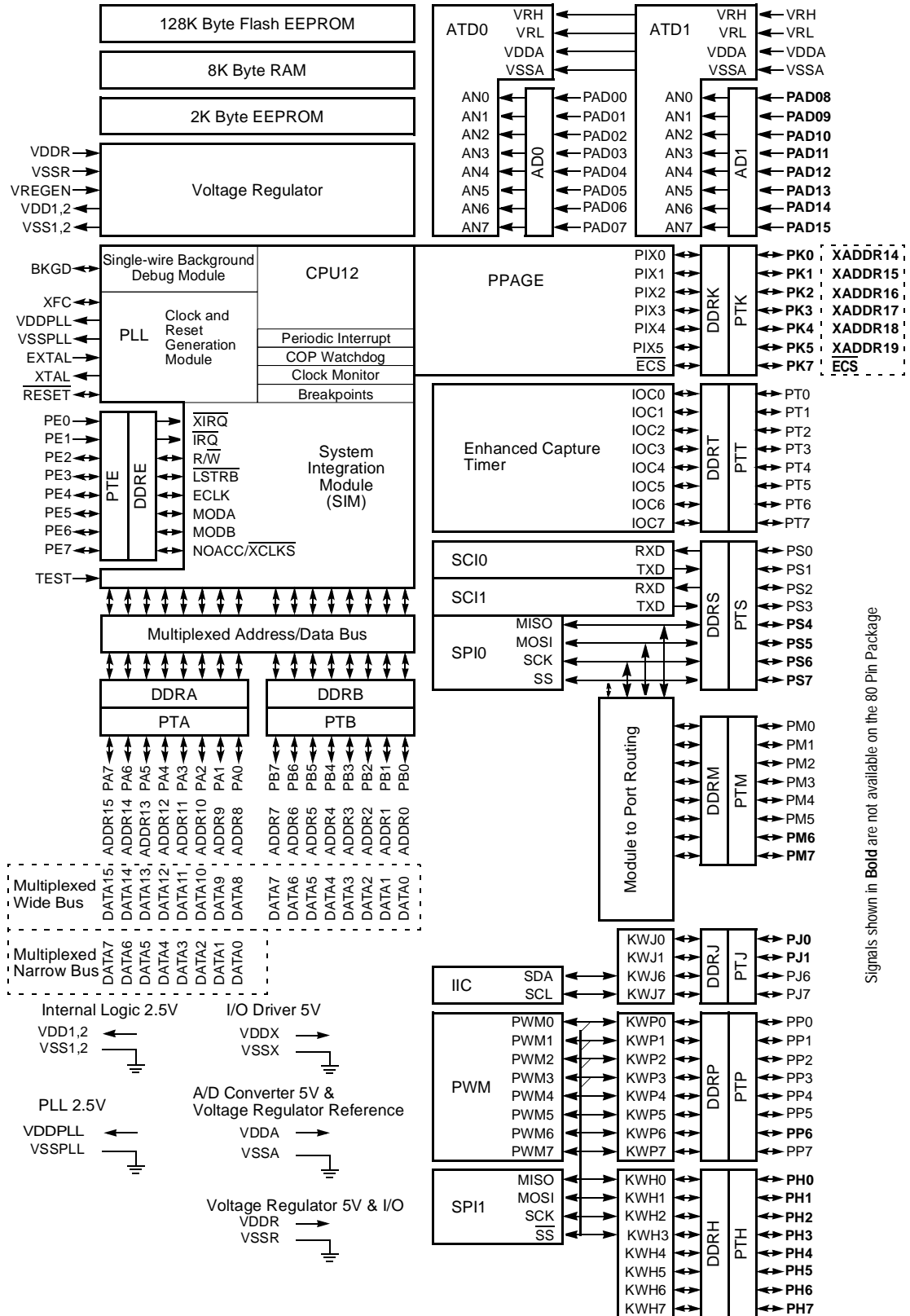

Signals shown in **Bold** are not available on the 80 Pin Package

1.5 Device Memory Map

Table 1-1 and **Figure 1-2** show the device memory map of the MC9S12A128 after reset. Note that after reset the bottom 1K of the EEPROM (\$0000 - \$03FF) are hidden by the register space.

Table 1-1 Device Memory Map

Address	Module	Size (Bytes)
\$0000 – \$0017	CORE (Ports A, B, E, Modes, Inits, Test)	24
\$0018 – \$0019	Reserved	2
\$001A – \$001B	Device ID register (PARTID)	2
\$001C – \$001F	CORE (MEMSIZ, IRQ, HPRIO)	4
\$0020 – \$0027	Reserved	8
\$0028 – \$002F	CORE (Background Debug Mode)	8
\$0030 – \$0033	CORE (PPAGE, Port K)	4
\$0034 – \$003F	Clock and Reset Generator (PLL, RTI, COP)	12
\$0040 – \$007F	Enhanced Capture Timer 16-bit 8 channels	64
\$0080 – \$009F	Analog to Digital Converter 10-bit 8 channels (ATD0)	32
\$00A0 – \$00C7	Pulse Width Modulator 8-bit 8 channels (PWM)	40
\$00C8 – \$00CF	Serial Communications Interface 0 (SCI0)	8
\$00D0 – \$00D7	Serial Communications Interface 0 (SCI1)	8
\$00D8 – \$00DF	Serial Peripheral Interface (SPI0)	8
\$00E0 – \$00E7	Inter IC Bus	8
\$00E8 – \$00EF	Reserved	8
\$00F0 – \$00F7	Serial Peripheral Interface (SPI1)	8
\$00F8 – \$00FF	Reserved	8
\$0100- \$010F	Flash Control Register	16
\$0110 – \$011B	EEPROM Control Register	12
\$011C – \$011F	Reserved	4
\$0120 – \$013F	Analog to Digital Converter 10-bit 8 channels (ATD1)	32
\$0140 – \$023F	Reserved	256
\$0240 – \$027F	Port Integration Module (PIM)	64
\$0280 – \$03FF	Reserved	384
\$0000 – \$07FF	EEPROM array	2048
\$0000 – \$1FFF	RAM array	8192
\$4000 – \$7FFF	Fixed Flash EEPROM array incl. 0.5K, 1K, 2K or 4K Protected Sector at start	16384
\$8000 – \$BFFF	Flash EEPROM Page Window	16384
\$C000 – \$FFFF	Fixed Flash EEPROM array incl. 0.5K, 1K, 2K or 4K Protected Sector at end and 256 bytes of Vector Space at \$FF80 – \$FFFF	16384

Figure 1-2 MC9S12A128 Memory Map

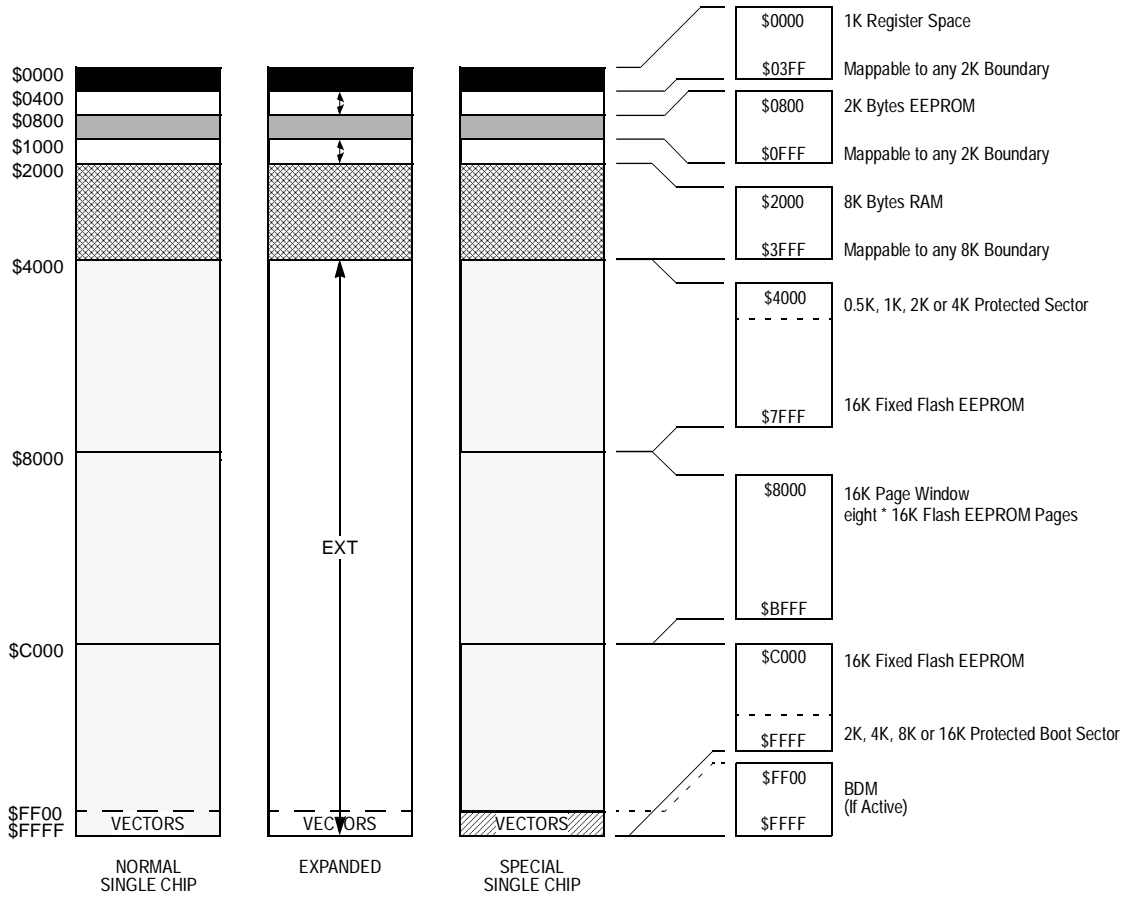

The address does not show the map after reset, but a useful map. After reset the map is:
 \$0000 - \$03FF: Register Space
 \$0000 - \$1FFF: 8K RAM
 \$0000 - \$07FF: 2K EEPROM (not visible)
 \$2000 - \$3FFF: 8K Flash

1.6 Part ID Assignments

The part ID is located in two 8-bit registers PARTIDH and PARTIDL (addresses \$001A and \$001B after reset). The read-only value is a unique part ID for each revision of the chip. **Table 1-2** shows the assigned part ID number.

Table 1-2 Assigned Part ID Numbers

Device	Mask Set Number	Part ID ¹
MC9S12A128	0L85D	\$0100

NOTES:

1. The coding is as follows:
 Bit 15-12: Major family identifier
 Bit 11-8: Minor family identifier
 Bit 7-4: Major mask set revision number including FAB transfers
 Bit 3-0: Minor - non full - mask set revision

The device memory sizes are located in two 8-bit registers MEMSIZ0 and MEMSIZ1 (addresses \$001C and \$001D after reset). **Table 1-3** shows the read-only values of these registers. Refer to the *HCS12 Core User Guide* (Motorola document order number HCS12COREUG/D) for further details.

Table 1-3 Memory Size Registers

Register name	Value
MEMSIZ0	\$13
MEMSIZ1	\$80

Section 2 Signal Description

This section describes signals that connect off-chip. It includes a pinout diagram, a table of signal properties, and detailed discussion of signals. It is built from the signal description sections of the Block Guides of the individual IP blocks on the device.

2.1 Device Pinout

The MC9S12A128 is available in a 112-pin low profile quad flat pack (LQFP) and is also available in a 80-pin quad flat pack (QFP). Most pins perform two or more functions, as described in the [2.3 Detailed Signal Descriptions](#). [Figure 2-1](#) and [Figure 2-2](#) show the pin assignments.

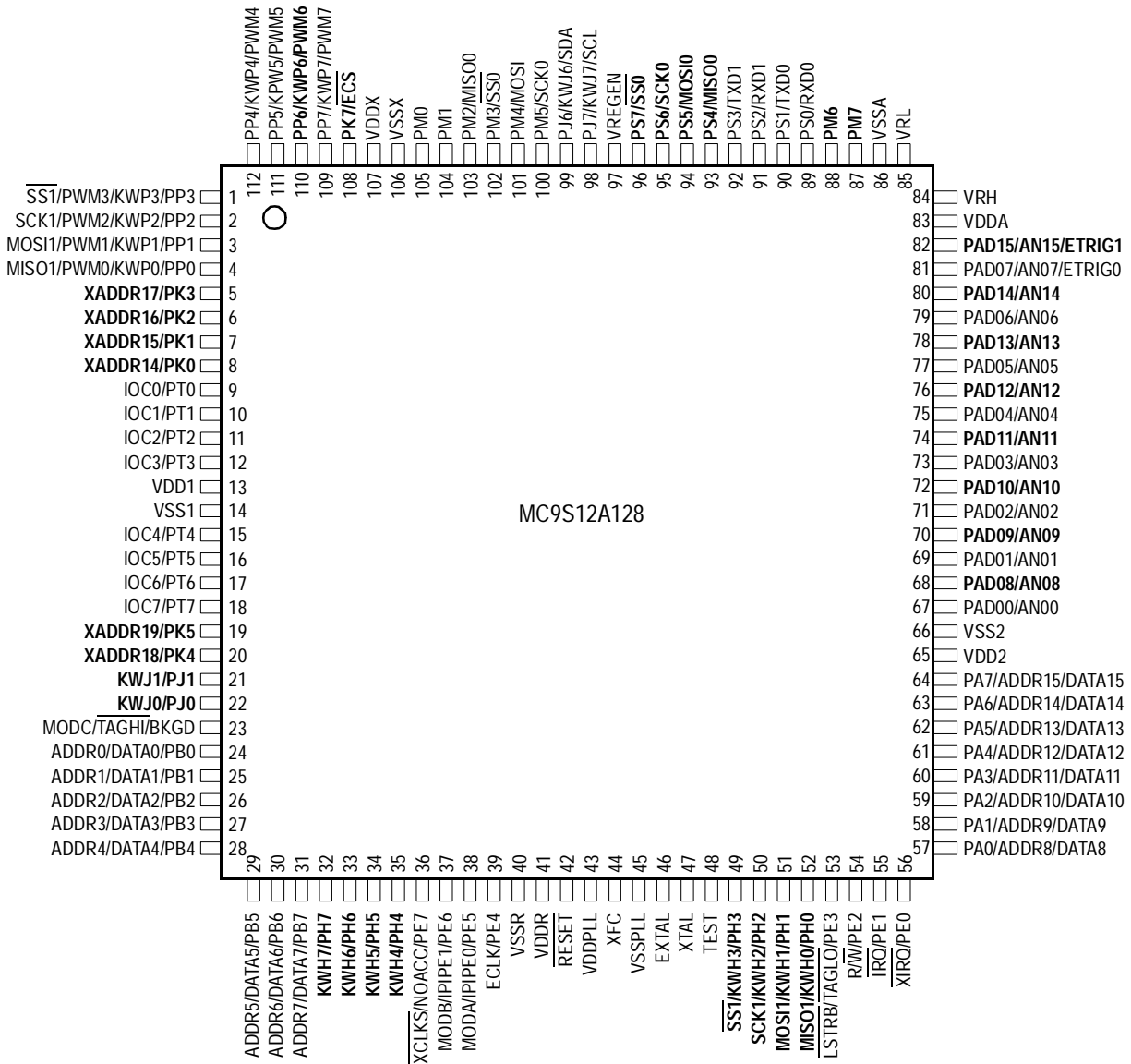

Signals shown in **Bold** are not available on the 80 Pin Package

Figure 2-1 Pin Assignments in 112-Pin LQFP

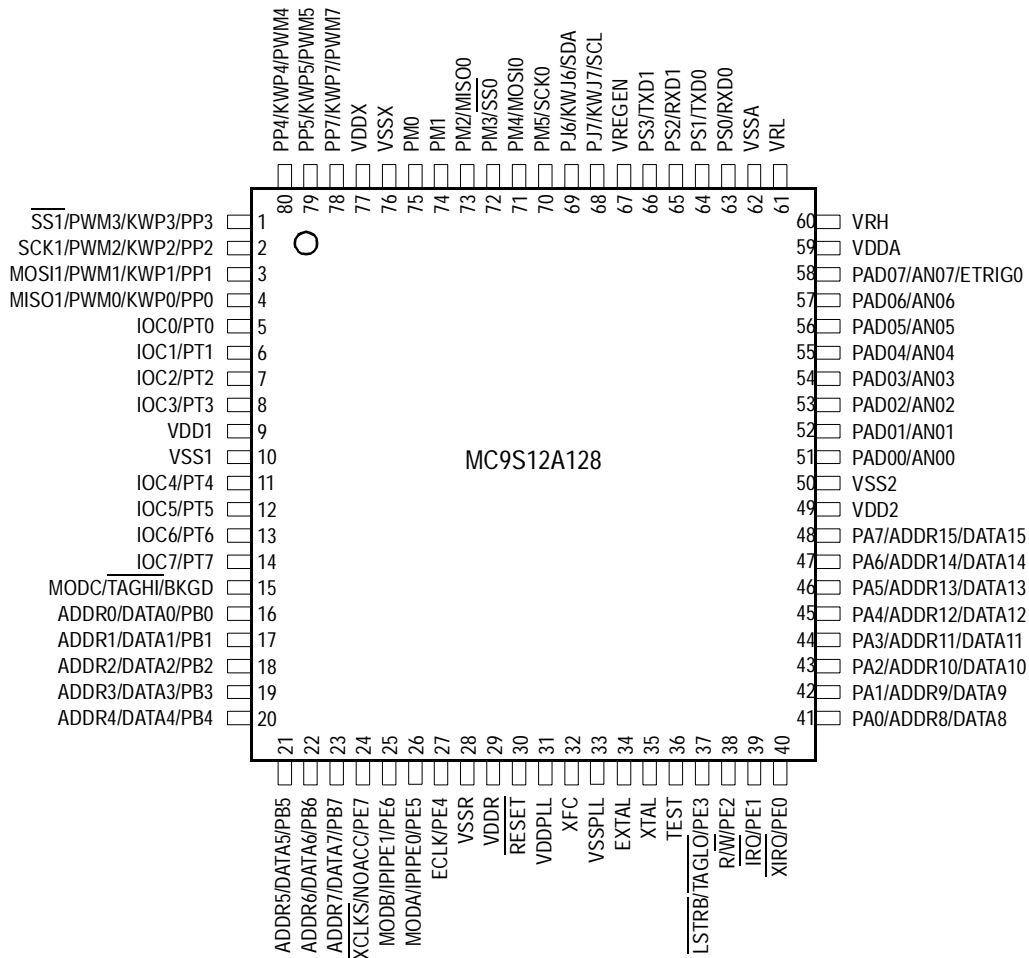

Figure 2-2 Pin Assignments in 80-Pin QFP for MC9S12A128

2.2 Signal Properties Summary

Table 2-1 summarizes the pin functionality. Signals shown in **bold** are not available in the 80 pin package.

Table 2-1 Signal Properties

Pin Name Function 1	Pin Name Function 2	Pin Name Function 3	Pin Name Function 4	Powered by	Description
EXTAL	—	—	—	V _{DDPLL}	Oscillator Pins
XTAL	—	—	—		
$\overline{\text{RESET}}$	—	—	—	V _{DDR}	External Reset
TEST	—	—	—	N.A.	Test Input
VREGEN	—	—	—	V _{DDX}	Voltage Regulator Enable Input
XFC	—	—	—	V _{DDPLL}	PLL Loop Filter
BKGD	$\overline{\text{TAGHI}}$	MODC	—	V _{DDR}	Background Debug, Tag High, Mode Input
PAD15	AN15	ETRIG1	—	V _{DDA}	Port AD Input, Analog Input AN7 of ATD1, External Trigger Input of ATD1
PAD[14:8]	AN[14:08]	—	—		Port AD Inputs, Analog Inputs AN[6:0] of ATD1
PAD07	AN07	ETRIG0	—		Port AD Input, Analog Input AN7 of ATD0, External Trigger Input of ATD0
PAD[06:00]	AN[06:00]	—	—		Port AD Inputs, Analog Inputs AN[6:0] of ATD0
PA[7:0]	ADDR[15:8]/ DATA[15:8]	—	—	V _{DDR}	Port A I/O, Multiplexed Address/Data
PB[7:0]	ADDR[7:0]/ DATA[7:0]	—	—		Port B I/O, Multiplexed Address/Data
PE7	NOACC	XCLKS	—		Port E I/O, Access, Clock Select
PE6	IPIPE1	MODB	—		Port E I/O, Pipe Status, Mode Input
PE5	IPIPE0	MODA	—		Port E I/O, Pipe Status, Mode Input
PE4	ECLK	—	—		Port E I/O, Bus Clock Output
PE3	LSTRB	TAGLO	—		Port E I/O, Byte Strobe, Tag Low
PE2	R/W	—	—		Port E I/O, R/W in expanded modes
PE1	IRQ	—	—		Port E Input, Maskable Interrupt
PE0	XIRQ	—	—		Port E Input, Non Maskable Interrupt
PH7	KWH7	—	—		Port H I/O, Interrupt
PH6	KWH6	—	—		Port H I/O, Interrupt
PH5	KWH5	—	—		Port H I/O, Interrupt
PH4	KWH4	—	—		Port H I/O, Interrupt
PH3	KWH3	SS1	—		Port H I/O, Interrupt, SS of SPI1
PH2	KWH2	SCK1	—		Port H I/O, Interrupt, SCK of SPI1
PH1	KWH1	MOSI1	—		Port H I/O, Interrupt, MOSI of SPI1
PH0	KWH0	MISO1	—		Port H I/O, Interrupt, MISO of SPI1

Pin Name Function 1	Pin Name Function 2	Pin Name Function 3	Pin Name Function 4	Powered by	Description
PJ7	KWJ7	SCL		V _{DDX}	Port J I/O, Interrupt, SCL of IIC
PJ6	KWJ6	SDA			Port J I/O, Interrupt, SDA of IIC
PJ[1:0]	KWJ[1:0]	—	—		Port J I/O, Interrupts
PK7	$\overline{\text{ECS}}$	ROMON	—		Port K I/O, Emulation Chip Select, ROM On Enable
PK[5:0]	XADDR[19:14]		—		Port K I/O, Extended Addresses
PM7	—	—	—		Port M I/O
PM6	—	—	—		Port M I/O
PM5	SCK0	—	—		Port M I/O, SCK of SPI0
PM4	MOSI0	—	—		Port M I/O, MOSI of SPI0
PM3	SS0	—	—		Port M I/O, SS of SPI0
PM2	MISO0	—	—		Port M I/O, MISO of SPI0
PM1	—	—	—		Port M I/O
PM0	—	—	—		Port M I/O
PP7	KWP7	PWM7	—		Port P I/O, Interrupt, Channel 7 of PWM
PP6	KWP6	PWM6	—		Port P I/O, Interrupt, Channel 6 of PWM
PP5	KWP5	PWM5	—		Port P I/O, Interrupt, Channel 5 of PWM
PP4	KWP4	PWM4	—		Port P I/O, Interrupt, Channel 4 of PWM
PP3	KWP3	PWM3	$\overline{\text{SS1}}$		Port P I/O, Interrupt, Channel 3 of PWM, $\overline{\text{SS}}$ of SPI1
PP2	KWP2	PWM2	SCK1		Port P I/O, Interrupt, Channel 2 of PWM, SCK of SPI1
PP1	KWP1	PWM1	MOSI1		Port P I/O, Interrupt, Channel 1 of PWM, MOSI of SPI1
PP0	KWP0	PWM0	MISO1		Port P I/O, Interrupt, Channel 0 of PWM, MISO of SPI1
PS7	SS0	—	—		Port S I/O, $\overline{\text{SS}}$ of SPI0
PS6	SCK0	—	—		Port S I/O, SCK of SPI0
PS5	MOSI0	—	—		Port S I/O, MOSI of SPI0
PS4	MISO0	—	—		Port S I/O, MISO of SPI0
PS3	TXD1	—	—		Port S I/O, TXD of SCI1
PS2	RXD1	—	—		Port S I/O, RXD of SCI1
PS1	TXD0	—	—		Port S I/O, TXD of SCI0
PS0	RXD0	—	—		Port S I/O, RXD of SCI0
PT[7:0]	IOC[7:0]	—	—		Port T I/O, Timer channels

2.3 Detailed Signal Descriptions

2.3.1 EXTAL, XTAL — Oscillator Pins

EXTAL and XTAL are the crystal driver and external clock pins. On reset all the device clocks are derived from the EXTAL input frequency. XTAL is the crystal output.

2.3.2 $\overline{\text{RESET}}$ — External Reset Pin

An active low bidirectional control signal, it acts as an input to initialize the MCU to a known start-up state, and an output when an internal MCU function causes a reset.

2.3.3 TEST — Test Pin

This input only pin is reserved for test.

NOTE: The TEST pin must be tied to V_{SS} in all applications.

2.3.4 V_{REGEN} — Voltage Regulator Enable Pin

This input only pin enables or disables the on-chip voltage regulator.

2.3.5 XFC — PLL Loop Filter Pin

PLL loop filter, see [A.5.3 Phase Locked Loop](#). If needed, contact your Motorola representative for the interactive application note to compute PLL loop filter elements. Any current leakage on this pin must be avoided.

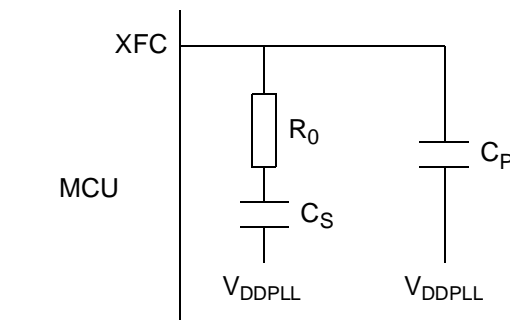

Figure 2-3 PLL Loop Filter Connections

2.3.6 BKGD / $\overline{\text{TAGHI}}$ / MODC — Background Debug, Tag High, and Mode Pin

The BKGD/ $\overline{\text{TAGHI}}$ /MODC pin is used as a pseudo-open-drain pin for the background debug communication. In MCU expanded modes of operation when instruction tagging is on, an input low on this pin during the falling edge of E-clock tags the high half of the instruction word being read into the instruction queue. It is used as a MCU operating mode select pin during reset. The state of this pin is latched to the MODC bit at the rising edge of $\overline{\text{RESET}}$.

2.3.7 PAD15 / AN15 / ETRIG1 — Port AD Input Pin of ATD1

PAD15 is a general purpose input pin and analog input AN7 of the analog to digital converter ATD1. It can act as an external trigger input for the ATD1.

2.3.8 PAD[14:08] / AN[14:08] — Port AD Input Pins of ATD1

PAD14 - PAD08 are general purpose input pins and analog inputs AN[6:0] of the analog to digital converter ATD1.

2.3.9 PAD7 / AN07 / ETRIG0 — Port AD Input Pin of ATD0

PAD7 is a general purpose input pin and analog input AN7 of the analog to digital converter ATD0. It can act as an external trigger input for the ATD0.

2.3.10 PAD[06:00] / AN[06:00] — Port AD Input Pins of ATD0

PAD06 - PAD00 are general purpose input pins and analog inputs AN[6:0] of the analog to digital converter ATD0.

2.3.11 PA[7:0] / ADDR[15:8] / DATA[15:8] — Port A I/O Pins

PA7-PA0 are general purpose input or output pins. In MCU expanded modes of operation, these pins are used for the multiplexed external address and data bus.

2.3.12 PB[7:0] / ADDR[7:0] / DATA[7:0] — Port B I/O Pins

PB7-PB0 are general purpose input or output pins. In MCU expanded modes of operation, these pins are used for the multiplexed external address and data bus.

2.3.13 PE7 / NOACC / $\overline{\text{XCLKS}}$ — Port E I/O Pin 7

PE7 is a general purpose input or output pin. During MCU expanded modes of operation, the NOACC signal, when enabled, is used to indicate that the current bus cycle is an unused or “free” cycle. This signal will assert when the CPU is not using the bus.

The $\overline{\text{XCLKS}}$ input selects between an external clock or oscillator configuration. The state of this pin is latched at the rising edge of $\overline{\text{RESET}}$. If the input is a logic low the EXTAL pin is configured for an external clock drive. If input is a logic high an oscillator circuit is configured on EXTAL and XTAL. Since this pin is an input with a pull-up device, if the pin is left floating, the default configuration is an oscillator circuit on EXTAL and XTAL.

2.3.14 PE6 / MODB / IPIPE1 — Port E I/O Pin 6

PE6 is a general purpose input or output pin. It is used as a MCU operating mode select pin during reset. The state of this pin is latched to the MODB bit at the rising edge of $\overline{\text{RESET}}$. This pin is shared with the instruction queue tracking signal IPIPE1. This pin is an input with a pull-down device which is only active when $\overline{\text{RESET}}$ is low.

2.3.15 PE5 / MODA / IPIPE0 — Port E I/O Pin 5

PE5 is a general purpose input or output pin. It is used as a MCU operating mode select pin during reset. The state of this pin is latched to the MODA bit at the rising edge of $\overline{\text{RESET}}$. This pin is shared with the instruction queue tracking signal IPIPE0. This pin is an input with a pull-down device which is only active when $\overline{\text{RESET}}$ is low.

2.3.16 PE4 / ECLK — Port E I/O Pin 4

PE4 is a general purpose input or output pin. It can be configured to drive the internal bus clock ECLK. ECLK can be used as a timing reference.

2.3.17 PE3 / $\overline{\text{LSTRB}}$ / $\overline{\text{TAGLO}}$ — Port E I/O Pin 3

PE3 is a general purpose input or output pin. In MCU expanded modes of operation, $\overline{\text{LSTRB}}$ can be used for the low-byte strobe function to indicate the type of bus access and when instruction tagging is on, $\overline{\text{TAGLO}}$ is used to tag the low half of the instruction word being read into the instruction queue.

2.3.18 PE2 / $\overline{\text{R/W}}$ — Port E I/O Pin 2

PE2 is a general purpose input or output pin. In MCU expanded modes of operations, this pin drives the read/write output signal for the external bus. It indicates the direction of data on the external bus.

2.3.19 PE1 / $\overline{\text{IRQ}}$ — Port E Input Pin 1

PE1 is a general purpose input pin and the maskable interrupt request input that provides a means of applying asynchronous interrupt requests. This will wake up the MCU from STOP or WAIT mode.

2.3.20 PE0 / $\overline{\text{XIRQ}}$ — Port E Input Pin 0

PE0 is a general purpose input pin and the non-maskable interrupt request input that provides a means of applying asynchronous interrupt requests. This will wake up the MCU from STOP or WAIT mode.

2.3.21 PH7 / KWH7 — Port H I/O Pin 7

PH7 is a general purpose input or output pin. It can be configured to generate an interrupt causing the MCU to exit STOP or WAIT mode.

2.3.22 PH6 / KWH6 — Port H I/O Pin 6

PH6 is a general purpose input or output pin. It can be configured to generate an interrupt causing the MCU to exit STOP or WAIT mode.

2.3.23 PH5 / KWH5 — Port H I/O Pin 5

PH5 is a general purpose input or output pin. It can be configured to generate an interrupt causing the MCU to exit STOP or WAIT mode.

2.3.24 PH4 / KWH4 — Port H I/O Pin 4

PH4 is a general purpose input or output pin. It can be configured to generate an interrupt causing the MCU to exit STOP or WAIT mode.

2.3.25 PH3 / KWH3 / $\overline{SS1}$ — Port H I/O Pin 3

PH3 is a general purpose input or output pin. It can be configured to generate an interrupt causing the MCU to exit STOP or WAIT mode. It can be configured as slave select pin \overline{SS} of the Serial Peripheral Interface 1 (SPI1).

2.3.26 PH2 / KWH2 / SCK1 — Port H I/O Pin 2

PH2 is a general purpose input or output pin. It can be configured to generate an interrupt causing the MCU to exit STOP or WAIT mode. It can be configured as serial clock pin SCK of the Serial Peripheral Interface 1 (SPI1).

2.3.27 PH1 / KWH1 / MOSI1 — Port H I/O Pin 1

PH1 is a general purpose input or output pin. It can be configured to generate an interrupt causing the MCU to exit STOP or WAIT mode. It can be configured as master output (during master mode) or slave input pin (during slave mode) MOSI of the Serial Peripheral Interface 1 (SPI1).

2.3.28 PH0 / KWH0 / MISO1 — Port H I/O Pin 0

PH0 is a general purpose input or output pin. It can be configured to generate an interrupt causing the MCU to exit STOP or WAIT mode. It can be configured as master input (during master mode) or slave output (during slave mode) pin MISO of the Serial Peripheral Interface 1 (SPI1).

2.3.29 PJ7 / KWJ7 / SCL — PORT J I/O Pin 7

PJ7 is a general purpose input or output pin. It can be configured to generate an interrupt causing the MCU to exit STOP or WAIT mode. It can be configured as the serial clock pin SCL of the IIC module.

2.3.30 PJ6 / KWJ6 / SDA — PORT J I/O Pin 6

PJ6 is a general purpose input or output pin. It can be configured to generate an interrupt causing the MCU to exit STOP or WAIT mode. It can be configured as the serial data pin SDA of the IIC module.

2.3.31 PJ[1:0] / KWJ[1:0] — Port J I/O Pins [1:0]

PJ1 and PJ0 are general purpose input or output pins. They can be configured to generate an interrupt causing the MCU to exit STOP or WAIT mode.

2.3.32 PK7 / $\overline{\text{ECS}}$ / ROMON — Port K I/O Pin 7

PK7 is a general purpose input or output pin. During MCU expanded modes of operation, this pin is used as the emulation chip select output ($\overline{\text{ECS}}$). During MCU normal expanded modes of operation, this pin is used to enable the Flash EEPROM memory in the memory map (ROMON). At the rising edge of $\overline{\text{RESET}}$, the state of this pin is latched to the ROMON bit.

2.3.33 PK[5:0] / XADDR[19:14] — Port K I/O Pins [5:0]

PK5-PK0 are general purpose input or output pins. In MCU expanded modes of operation, these pins provide the expanded address XADDR[19:14] for the external bus.

2.3.34 PM7 — Port M I/O Pin 7

PM7 is a general purpose input or output pin.

2.3.35 PM6 — Port M I/O Pin 6

PM6 is a general purpose input or output pin.

2.3.36 PM5 / SCK0 — Port M I/O Pin 5

PM5 is a general purpose input or output pin. It can be configured as the serial clock pin SCK of the Serial Peripheral Interface 0 (SPI0).

2.3.37 PM4 / MOSI0 — Port M I/O Pin 4

PM4 is a general purpose input or output pin. It can be configured as the master output (during master mode) or slave input pin (during slave mode) MOSI for the Serial Peripheral Interface 0 (SPI0).

2.3.38 PM3 / $\overline{SS0}$ — Port M I/O Pin 3

PM3 is a general purpose input or output pin. It can be configured as the slave select pin \overline{SS} of the Serial Peripheral Interface 0 (SPI0).

2.3.39 PM2 / MISO0 — Port M I/O Pin 2

PM2 is a general purpose input or output pin. It can be configured as the master input (during master mode) or slave output pin (during slave mode) MISO for the Serial Peripheral Interface 0 (SPI0).

2.3.40 PM1 — Port M I/O Pin 1

PM1 is a general purpose input or output pin.

2.3.41 PM0 — Port M I/O Pin 0

PM0 is a general purpose input or output pin.

2.3.42 PP7 / KWP7 / PWM7 — Port P I/O Pin 7

PP7 is a general purpose input or output pin. It can be configured to generate an interrupt causing the MCU to exit STOP or WAIT mode. It can be configured as Pulse Width Modulator (PWM) channel 7 output.

2.3.43 PP6 / KWP6 / PWM6 — Port P I/O Pin 6

PP6 is a general purpose input or output pin. It can be configured to generate an interrupt causing the MCU to exit STOP or WAIT mode. It can be configured as Pulse Width Modulator (PWM) channel 6 output.

2.3.44 PP5 / KWP5 / PWM5 — Port P I/O Pin 5

PP5 is a general purpose input or output pin. It can be configured to generate an interrupt causing the MCU to exit STOP or WAIT mode. It can be configured as Pulse Width Modulator (PWM) channel 5 output.

2.3.45 PP4 / KWP4 / PWM4 — Port P I/O Pin 4

PP4 is a general purpose input or output pin. It can be configured to generate an interrupt causing the MCU to exit STOP or WAIT mode. It can be configured as Pulse Width Modulator (PWM) channel 4 output.

2.3.46 PP3 / KWP3 / PWM3 / $\overline{SS1}$ — Port P I/O Pin 3

PP3 is a general purpose input or output pin. It can be configured to generate an interrupt causing the MCU to exit STOP or WAIT mode. It can be configured as Pulse Width Modulator (PWM) channel 3 output. It can be configured as slave select pin \overline{SS} of the Serial Peripheral Interface 1 (SPI1).

2.3.47 PP2 / KWP2 / PWM2 / SCK1 — Port P I/O Pin 2

PP2 is a general purpose input or output pin. It can be configured to generate an interrupt causing the MCU to exit STOP or WAIT mode. It can be configured as Pulse Width Modulator (PWM) channel 2 output. It can be configured as serial clock pin SCK of the Serial Peripheral Interface 1 (SPI1).

2.3.48 PP1 / KWP1 / PWM1 / MOSI1 — Port P I/O Pin 1

PP1 is a general purpose input or output pin. It can be configured to generate an interrupt causing the MCU to exit STOP or WAIT mode. It can be configured as Pulse Width Modulator (PWM) channel 1 output. It can be configured as master output (during master mode) or slave input pin (during slave mode) MOSI of the Serial Peripheral Interface 1 (SPI1).

2.3.49 PP0 / KWP0 / PWM0 / MISO1 — Port P I/O Pin 0

PP0 is a general purpose input or output pin. It can be configured to generate an interrupt causing the MCU to exit STOP or WAIT mode. It can be configured as Pulse Width Modulator (PWM) channel 0 output. It can be configured as master input (during master mode) or slave output (during slave mode) pin MISO of the Serial Peripheral Interface 1 (SPI1).

2.3.50 PS7 / $\overline{SS0}$ — Port S I/O Pin 7

PS7 is a general purpose input or output pin. It can be configured as the slave select pin \overline{SS} of the Serial Peripheral Interface 0 (SPI0).

2.3.51 PS6 / SCK0 — Port S I/O Pin 6

PS6 is a general purpose input or output pin. It can be configured as the serial clock pin SCK of the Serial Peripheral Interface 0 (SPI0).

2.3.52 PS5 / MOSI0 — Port S I/O Pin 5

PS5 is a general purpose input or output pin. It can be configured as master output (during master mode) or slave input pin (during slave mode) MOSI of the Serial Peripheral Interface 0 (SPI0).

2.3.53 PS4 / MISO0 — Port S I/O Pin 4

PS4 is a general purpose input or output pin. It can be configured as master input (during master mode) or slave output pin (during slave mode) MOSI of the Serial Peripheral Interface 0 (SPI0).

2.3.54 PS3 / TXD1 — Port S I/O Pin 3

PS3 is a general purpose input or output pin. It can be configured as the transmit pin TXD of Serial Communication Interface 1 (SCI1).

2.3.55 PS2 / RXD1 — Port S I/O Pin 2

PS2 is a general purpose input or output pin. It can be configured as the receive pin RXD of Serial Communication Interface 1 (SCI1).

2.3.56 PS1 / TXD0 — Port S I/O Pin 1

PS1 is a general purpose input or output pin. It can be configured as the transmit pin TXD of Serial Communication Interface 0 (SCI0).

2.3.57 PS0 / RXD0 — Port S I/O Pin 0

PS0 is a general purpose input or output pin. It can be configured as the receive pin RXD of Serial Communication Interface 0 (SCI0).

2.3.58 PT[7:0] / IOC[7:0] — Port T I/O Pins [7:0]

PT7-PT0 are general purpose input or output pins. They can be configured as input capture or output compare pins IOC7-IOC0 of the Enhanced Capture Timer (ECT).

2.4 Power Supply Pins

MC9S12A128 power and ground pins are described below.

NOTE: All V_{SS} pins must be connected together in the application.

2.4.1 V_{DDX} , V_{SSX} — Power & Ground Pins for I/O Drivers

External power and ground for I/O drivers. Because fast signal transitions place high, short-duration current demands on the power supply, use bypass capacitors with high-frequency characteristics and place them as close to the MCU as possible. Bypass requirements depend on how heavily the MCU pins are loaded.

2.4.2 V_{DDR} , V_{SSR} — Power & Ground Pins for I/O Drivers & for Internal Voltage Regulator

External power and ground for I/O drivers and input to the internal voltage regulator. Because fast signal transitions place high, short-duration current demands on the power supply, use bypass capacitors with high-frequency characteristics and place them as close to the MCU as possible. Bypass requirements depend on how heavily the MCU pins are loaded.

2.4.3 V_{DD1} , V_{DD2} , V_{SS1} , V_{SS2} — Core Power Pins

Power is supplied to the MCU through V_{DD} and V_{SS} . Because fast signal transitions place high, short-duration current demands on the power supply, use bypass capacitors with high-frequency characteristics and place them as close to the MCU as possible. This 2.5V supply is derived from the internal voltage regulator. There is no static load on those pins allowed. The internal voltage regulator is turned off, if V_{REGEN} is tied to ground.

NOTE: *No load allowed except for bypass capacitors.*

2.4.4 V_{DDA} , V_{SSA} — Power Supply Pins for ATD and VREG

V_{DDA} , V_{SSA} are the power supply and ground input pins for the voltage regulator and the analog to digital converter. It also provides the reference for the internal voltage regulator. This allows the supply voltage to the ATD and the reference voltage to be bypassed independently.

2.4.5 V_{RH} , V_{RL} — ATD Reference Voltage Input Pins

V_{RH} and V_{RL} are the reference voltage input pins for the analog to digital converter.

2.4.6 V_{DDPLL} , V_{SSPLL} — Power Supply Pins for PLL

Provides operating voltage and ground for the Oscillator and the Phased-Locked Loop. This allows the supply voltage to the Oscillator and PLL to be bypassed independently. This 2.5V voltage is generated by the internal voltage regulator.

NOTE: *No load allowed except for bypass capacitors.*

2.4.7 V_{REGEN} — On Chip Voltage Regulator Enable

Enables the internal 5V to 2.5V voltage regulator. If this pin is tied low, $V_{DD1,2}$ and V_{DDPLL} must be supplied externally.

Table 2-2 MC9S12A128 Power and Ground Connection Summary

Mnemonic	Pin Number	Nominal Voltage	Description
	112-pin QFP		
V _{DD1,2}	13, 65	2.5 V	Internal power and ground generated by internal regulator
V _{SS1,2}	14, 66	0V	
V _{DDR}	41	5.0 V	External power and ground, supply to pin drivers and internal voltage regulator.
V _{SSR}	40	0 V	
V _{DDX}	107	5.0 V	External power and ground, supply to pin drivers.
V _{SSX}	106	0 V	
V _{DDA}	83	5.0 V	Operating voltage and ground for the analog-to-digital converters and the reference for the internal voltage regulator, allows the supply voltage to the A/D to be bypassed independently.
V _{SSA}	86	0 V	
V _{RL}	85	0 V	Reference voltages for the analog-to-digital converter.
V _{RH}	84	5.0 V	
V _{DDPLL}	43	2.5 V	Provides operating voltage and ground for the Phased-Locked Loop. This allows the supply voltage to the PLL to be bypassed independently. Internal power and ground generated by internal regulator.
V _{SSPLL}	45	0 V	
V _{REGEN}	97	5V	Internal Voltage Regulator enable/disable

Section 3 System Clock Description

3.1 Overview

The Clock and Reset Generator provides the internal clock signals for the core and all peripheral modules. **Figure 3-1** shows the clock connections from the CRG to all modules.

Consult the *HCS12 Clock and Reset Generator (CRG) Block Guide* (Motorola document order number, S12CRGV3/D) for details on clock generation.

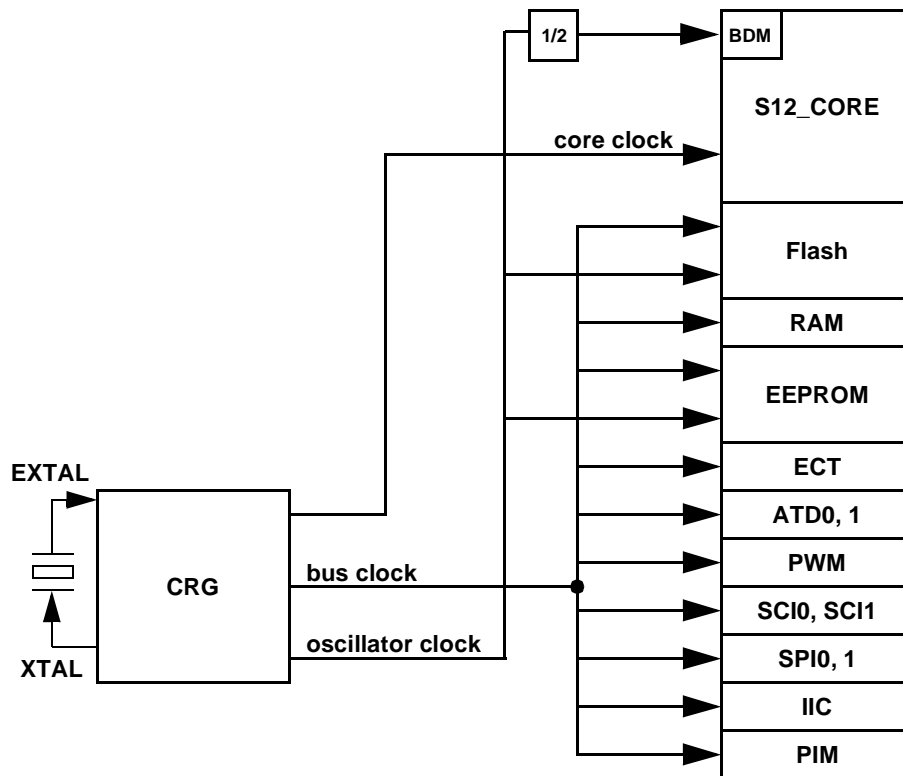

Figure 3-1 Clock Connections

Section 4 Modes of Operation

4.1 Overview

Eight possible modes determine the operating configuration of the MC9S12A128. Each mode has an associated default memory map and external bus configuration.

Three low power modes exist for the device.

4.2 Modes of Operation

The operating mode out of reset is determined by the states of the MODC, MODB, and MODA pins during reset ([Table 4-1](#)). The MODC, MODB, and MODA bits in the MODE register show the current operating mode and provide limited mode switching during operation. The states of the MODC, MODB, and MODA pins are latched into these bits on the rising edge of the reset signal.

Table 4-1 Mode Selection

MODC	MODB	MODA	Mode Description
0	0	0	Special Single Chip, BDM allowed and ACTIVE. BDM is allowed in all other modes but a serial command is required to make BDM active.
0	0	1	Emulation Expanded Narrow, BDM allowed
0	1	0	Special Test (Expanded Wide), BDM allowed
0	1	1	Emulation Expanded Wide, BDM allowed
1	0	0	Normal Single Chip, BDM allowed
1	0	1	Normal Expanded Narrow, BDM allowed
1	1	0	Peripheral; BDM allowed but bus operations would cause bus conflicts (must not be used)
1	1	1	Normal Expanded Wide, BDM allowed

There are two basic types of operating modes:

1. **Normal** modes: Some registers and bits are protected against accidental changes.
2. **Special** modes: Allow greater access to protected control registers and bits for special purposes such as testing.

A system development and debug feature, background debug mode (BDM), is available in all modes. In special single-chip mode, BDM is active immediately after reset.

Some aspects of Port E are not mode dependent. Bit 1 of Port E is a general purpose input or the $\overline{\text{IRQ}}$ interrupt input. $\overline{\text{IRQ}}$ can be enabled by bits in the CPU's condition codes register but it is inhibited at reset so this pin is initially configured as a simple input with a pull-up. Bit 0 of Port E is a general purpose input or the $\overline{\text{XIRQ}}$ interrupt input. $\overline{\text{XIRQ}}$ can be enabled by bits in the CPU's condition codes register but it is inhibited at reset so this pin is initially configured as a simple input with a pull-up. The ESTR bit in the EBICTL register is set to one by reset in any user mode. This assures that the reset vector can be fetched

even if it is located in an external slow memory device. The PE6/MODB/IPIPE1 and PE5/MODA/IPIPE0 pins act as high-impedance mode select inputs during reset.

The following paragraphs discuss the default bus setup and describe which aspects of the bus can be changed after reset on a per mode basis.

4.2.1 Normal Operating Modes

These modes provide three operating configurations. Background debug is available in all three modes, but must first be enabled for some operations by means of a BDM background command, then activated.

4.2.1.1 Normal Single-Chip Mode

There is no external expansion bus in this mode. All pins of Ports A, B and E are configured as general purpose I/O pins. Port E bits 1 and 0 are available as general purpose input only pins with internal pull-ups enabled. All other pins of Port E are bidirectional I/O pins that are initially configured as high-impedance inputs with internal pull-ups enabled. Ports A and B are configured as high-impedance inputs with their internal pull-ups disabled.

The pins associated with Port E bits 6, 5, 3, and 2 cannot be configured for their alternate functions IPIPE1, IPIPE0, LSTRB, and $\overline{R/W}$ while the MCU is in single chip modes. In single chip modes, the associated control bits PIPOE, LSTRE, and RDWE are reset to zero. Writing the opposite state into them in single chip mode does not change the operation of the associated Port E pins.

In normal single chip mode, the MODE register is writable one time. This allows a user program to change the bus mode to narrow or wide expanded mode and/or turn on visibility of internal accesses.

Port E, bit 4 can be configured for a free-running E clock output by clearing NECLK=0. Typically the only use for an E clock output while the MCU is in single chip modes would be to get a constant speed clock for use in the external application system.

4.2.1.2 Normal Expanded Wide Mode

In expanded wide modes, Ports A and B are configured as a 16-bit multiplexed address and data bus and Port E bit 4 is configured as the E clock output signal. These signals allow external memory and peripheral devices to be interfaced to the MCU.

Port E pins other than PE4/ECLK are configured as general purpose I/O pins (initially high-impedance inputs with internal pull-up resistors enabled). Control bits PIPOE, NECLK, LSTRE, and RDWE in the PEAR register can be used to configure Port E pins to act as bus control outputs instead of general purpose I/O pins.

It is possible to enable the pipe status signals on Port E bits 6 and 5 by setting the PIPOE bit in PEAR, but it would be unusual to do so in this mode. Development systems where pipe status signals are monitored would typically use the special variation of this mode.

The Port E bit 2 pin can be reconfigured as the $\overline{R/W}$ bus control signal by writing “1” to the RDWE bit in PEAR. If the expanded system includes external devices that can be written, such as RAM, the RDWE bit

would need to be set before any attempt to write to an external location. If there are no writable resources in the external system, PE2 can be left as a general purpose I/O pin.

The Port E bit 3 pin can be reconfigured as the $\overline{\text{LSTRB}}$ bus control signal by writing “1” to the LSTRE bit in PEAR. The default condition of this pin is a general purpose input because the $\overline{\text{LSTRB}}$ function is not needed in all expanded wide applications.

The Port E bit 4 pin is initially configured as ECLK output with stretch. The E clock output function depends upon the settings of the NECLK bit in the PEAR register, the IVIS bit in the MODE register and the ESTR bit in the EBICTL register. The E clock is available for use in external select decode logic or as a constant speed clock for use in the external application system.

4.2.1.3 Normal Expanded Narrow Mode

This mode is used for lower cost production systems that use 8-bit wide external EPROMs or RAMs. Such systems take extra bus cycles to access 16-bit locations but this may be preferred over the extra cost of additional external memory devices.

Ports A and B are configured as a 16-bit address bus and Port A is multiplexed with data. Internal visibility is not available in this mode because the internal cycles would need to be split into two 8-bit cycles.

Since the PEAR register can only be written one time in this mode, use care to set all bits to the desired states during the single allowed write.

The PE3/ $\overline{\text{LSTRB}}$ pin is always a general purpose I/O pin in normal expanded narrow mode. Although it is possible to write the LSTRE bit in PEAR to “1” in this mode, the state of LSTRE is overridden and Port E bit 3 cannot be reconfigured as the $\overline{\text{LSTRB}}$ output.

It is possible to enable the pipe status signals on Port E bits 6 and 5 by setting the PIPOE bit in PEAR, but it would be unusual to do so in this mode. $\overline{\text{LSTRB}}$ would also be needed to fully understand system activity. Development systems where pipe status signals are monitored would typically use special expanded wide mode or occasionally special expanded narrow mode.

The PE4/ECLK pin is initially configured as ECLK output with stretch. The E clock output function depends upon the settings of the NECLK bit in the PEAR register, the IVIS bit in the MODE register and the ESTR bit in the EBICTL register. In normal expanded narrow mode, the E clock is available for use in external select decode logic or as a constant speed clock for use in the external application system.

The PE2/R/W pin is initially configured as a general purpose input with a pull-up but this pin can be reconfigured as the $\overline{\text{R/W}}$ bus control signal by writing “1” to the RDWE bit in PEAR. If the expanded narrow system includes external devices that can be written such as RAM, the RDWE bit would need to be set before any attempt to write to an external location. If there are no writable resources in the external system, PE2 can be left as a general purpose I/O pin.

4.2.1.4 Internal Visibility

Internal visibility is available when the MCU is operating in expanded wide modes or emulation narrow mode. It is not available in single-chip, peripheral or normal expanded narrow modes. Internal visibility is enabled by setting the IVIS bit in the MODE register.

If an internal access is made while \overline{E} , $\overline{R/\overline{W}}$, and \overline{LSTRB} are configured as bus control outputs and internal visibility is off ($IVIS=0$), \overline{E} will remain low for the cycle, $\overline{R/\overline{W}}$ will remain high, and address, data and the \overline{LSTRB} pins will remain at their previous state.

When internal visibility is enabled ($IVIS=1$), certain internal cycles will be blocked from going external. During cycles when the BDM is selected, $\overline{R/\overline{W}}$ will remain high, data will maintain its previous state, and address and \overline{LSTRB} pins will be updated with the internal value. During CPU no access cycles when the BDM is not driving, $\overline{R/\overline{W}}$ will remain high, and address, data and the \overline{LSTRB} pins will remain at their previous state.

4.2.1.5 Emulation Expanded Wide Mode

In expanded wide modes, Ports A and B are configured as a 16-bit multiplexed address and data bus and Port E provides bus control and status signals. These signals allow external memory and peripheral devices to be interfaced to the MCU. These signals can also be used by a logic analyzer to monitor the progress of application programs.

The bus control related pins in Port E ($PE7/NOACC$, $PE6/MODB/IPIPE1$, $PE5/MODA/IPIPE0$, $PE4/ECLK$, $PE3/\overline{LSTRB}/\overline{TAGLO}$, and $PE2/\overline{R/\overline{W}}$) are all configured to serve their bus control output functions rather than general purpose I/O. Notice that writes to the bus control enable bits in the PEAR register in emulation mode are restricted.

4.2.1.6 Emulation Expanded Narrow Mode

Expanded narrow modes are intended to allow connection of single 8-bit external memory devices for lower cost systems that do not need the performance of a full 16-bit external data bus. Accesses to internal resources that have been mapped external (i.e. PORTA, PORTB, DDRA, DDRB, PORTE, DDRE, PEAR, PUCR, RDRIV) will be accessed with a 16-bit data bus on Ports A and B. Accesses of 16-bit external words to addresses which are normally mapped external will be broken into two separate 8-bit accesses using Port A as an 8-bit data bus. Internal operations continue to use full 16-bit data paths. They are only visible externally as 16-bit information if $IVIS=1$.

Ports A and B are configured as multiplexed address and data output ports. During external accesses, address A15, data D15 and D7 are associated with PA7, address A0 is associated with PB0 and data D8 and D0 are associated with PA0. During internal visible accesses and accesses to internal resources that have been mapped external, address A15 and data D15 is associated with PA7 and address A0 and data D0 is associated with PB0.

The bus control related pins in Port E ($PE7/NOACC$, $PE6/MODB/IPIPE1$, $PE5/MODA/IPIPE0$, $PE4/ECLK$, $PE3/\overline{LSTRB}/\overline{TAGLO}$, and $PE2/\overline{R/\overline{W}}$) are all configured to serve their bus control output functions rather than general purpose I/O. Notice that writes to the bus control enable bits in the PEAR register in emulation mode are restricted.

The main difference between special modes and normal modes is that some of the bus control and system control signals cannot be written in emulation modes.

4.2.2 Special Operating Modes

There are two special operating modes that correspond to normal operating modes. These operating modes are commonly used in factory testing and system development.

4.2.2.1 Special Single-Chip Mode

When the MCU is reset in this mode, the background debug mode is enabled and active. The MCU does not fetch the reset vector and execute application code as it would in other modes. Instead the active background mode is in control of CPU execution and BDM firmware is waiting for additional serial commands through the BKGD pin. When a serial command instructs the MCU to return to normal execution, the system will be configured as described below unless the reset states of internal control registers have been changed through background commands after the MCU was reset.

There is no external expansion bus after reset in this mode. Ports A and B are initially simple bidirectional I/O pins that are configured as high-impedance inputs with internal pull-ups disabled; however, writing to the mode select bits in the MODE register (which is allowed in special modes) can change this after reset. All of the Port E pins (except PE4/ECLK) are initially configured as general purpose high-impedance inputs with pull-ups enabled. PE4/ECLK is configured as the E clock output in this mode.

The pins associated with Port E bits 6, 5, 3, and 2 cannot be configured for their alternate functions IPIPE1, IPIPE0, $\overline{\text{LSTRB}}$, and $\text{R}/\overline{\text{W}}$ while the MCU is in single chip modes. In single chip modes, the associated control bits PIPOE, LSTRE and RDWE are reset to zero. Writing the opposite value into these bits in single chip mode does not change the operation of the associated Port E pins.

Port E, bit 4 can be configured for a free-running E clock output by clearing NECLK=0. Typically the only use for an E clock output while the MCU is in single chip modes would be to get a constant speed clock for use in the external application system.

4.2.2.2 Special Test Mode

In expanded wide modes, Ports A and B are configured as a 16-bit multiplexed address and data bus and Port E provides bus control and status signals. In special test mode, the write protection of many control bits is lifted so that they can be thoroughly tested without needing to go through reset.

4.2.3 Test Operating Mode

There is a test operating mode in which an external master, such as an I.C. tester, can control the on-chip peripherals.

4.2.3.1 Peripheral Mode

This mode is intended for Motorola factory testing of the MCU. In this mode, the CPU is inactive and an external (tester) bus master drives address, data and bus control signals in through Ports A, B and E. In effect, the whole MCU acts as if it was a peripheral under control of an external CPU. This allows faster testing of on-chip memory and peripherals than previous testing methods. Since the mode control register is not accessible in peripheral mode, the only way to change to another mode is to reset the MCU into a different mode. Background debugging should not be used while the MCU is in special peripheral mode

as internal bus conflicts between BDM and the external master can cause improper operation of both functions.

4.3 Security

The device will make available a security feature preventing the unauthorized read and write of the memory contents. This feature allows:

- Protection of the contents of FLASH,
- Protection of the contents of EEPROM,
- Operation in single-chip mode,
- Operation from external memory with internal FLASH and EEPROM disabled.

The user must be reminded that part of the security must lie with the user's code. An extreme example would be user's code that dumps the contents of the internal program. This code would defeat the purpose of security. At the same time the user may also wish to put a back door in the user's program. An example of this is the user downloads a key through the SCI which allows access to a programming routine that updates parameters stored in EEPROM.

4.3.1 Securing the Microcontroller

Once the user has programmed the FLASH and EEPROM (if desired), the part can be secured by programming the security bits located in the FLASH module. These non-volatile bits will keep the part secured through resetting the part and through powering down the part.

The security byte resides in a portion of the Flash array.

Check the *HCS12 128K Flash Block Guide* (Motorola document order number, S12FTS128KV1/D) for more details on the security configuration.

4.3.2 Operation of the Secured Microcontroller

4.3.2.1 Normal Single Chip Mode

This will be the most common usage of the secured part. Everything will appear the same as if the part was not secured with the exception of BDM operation. The BDM operation will be blocked.

4.3.2.2 Executing from External Memory

The user may wish to execute from external space with a secured microcontroller. This is accomplished by resetting directly into expanded mode. The internal FLASH and EEPROM will be disabled. BDM operations will be blocked.

4.3.3 Unsecuring the Microcontroller

In order to unsecure the microcontroller, the internal FLASH and EEPROM must be erased. This can be done through an external program in expanded mode.

Once the user has erased the FLASH and EEPROM, the part can be reset into special single chip mode. This invokes a program that verifies the erasure of the internal FLASH and EEPROM. Once this program completes, the user can erase and program the FLASH security bits to the unsecured state. This is generally done through the BDM, but the user could also change to expanded mode (by writing the mode bits through the BDM) and jumping to an external program (again through BDM commands). Note that if the part goes through a reset before the security bits are reprogrammed to the unsecure state, the part will be secured again.

4.4 Low Power Modes

Consult the respective Block Guide for information on the module behavior in Stop, Pseudo Stop, and Wait Mode.

Section 5 Resets and Interrupts

5.1 Overview

Consult the Exception Processing section of the *HCS12 Core User Guide* (Motorola document order number HCS12COREUG/D) for information on resets and interrupts.

5.2 Vectors

5.2.1 Vector Table

Table 5-1 lists interrupt sources and vectors in default order of priority.

Table 5-1 Interrupt Vector Locations

Vector Address	Interrupt Source	CCR Mask	Local Enable	HPRIO Value to Elevate
\$FFFE, \$FFFF	Reset	None	None	–
\$FFFC, \$FFFD	Clock Monitor fail reset	None	PLLCTL (CME, SCME)	–
\$FFFA, \$FFFB	COP failure reset	None	COP rate select	–
\$FFF8, \$FFF9	Unimplemented instruction trap	None	None	–
\$FFF6, \$FFF7	SWI	None	None	–
\$FFF4, \$FFF5	XIRQ	X-Bit	None	–
\$FFF2, \$FFF3	IRQ	I-Bit	IRQCR (IRQEN)	\$F2
\$FFF0, \$FFF1	Real Time Interrupt	I-Bit	CRGINT (RTIE)	\$F0
\$FFEE, \$FFEF	Enhanced Capture Timer channel 0	I-Bit	TIE (C0I)	\$EE
\$FFEC, \$FFED	Enhanced Capture Timer channel 1	I-Bit	TIE (C1I)	\$EC
\$FFEA, \$FFEB	Enhanced Capture Timer channel 2	I-Bit	TIE (C2I)	\$EA
\$FFE8, \$FFE9	Enhanced Capture Timer channel 3	I-Bit	TIE (C3I)	\$E8
\$FFE6, \$FFE7	Enhanced Capture Timer channel 4	I-Bit	TIE (C4I)	\$E6
\$FFE4, \$FFE5	Enhanced Capture Timer channel 5	I-Bit	TIE (C5I)	\$E4
\$FFE2, \$FFE3	Enhanced Capture Timer channel 6	I-Bit	TIE (C6I)	\$E2
\$FFE0, \$FFE1	Enhanced Capture Timer channel 7	I-Bit	TIE (C7I)	\$E0
\$FFDE, \$FFDF	Enhanced Capture Timer overflow	I-Bit	TSRC2 (TOF)	\$DE
\$FFDC, \$FFDD	Pulse accumulator A overflow	I-Bit	PACTL (PAOVI)	\$DC
\$FFDA, \$FFDB	Pulse accumulator input edge	I-Bit	PACTL (PAI)	\$DA
\$FFD8, \$FFD9	SPIO	I-Bit	SPOCR1 (SPIE, SPTIE)	\$D8
\$FFD6, \$FFD7	SCIO	I-Bit	SC0CR2 (TIE, TCIE, RIE, ILIE)	\$D6
\$FFD4, \$FFD5	SCI1	I-Bit	SC1CR2 (TIE, TCIE, RIE, ILIE)	\$D4
\$FFD2, \$FFD3	ATD0	I-Bit	ATDOCTL2 (ASCIE)	\$D2
\$FFD0, \$FFD1	ATD1	I-Bit	ATD1CTL2 (ASCIE)	\$D0
\$FFCE, \$FFCF	Port J	I-Bit	PTJIF (PTJIE)	\$CE
\$FFCC, \$FFCD	Port H	I-Bit	PTHIF (PTHIE)	\$CC
\$FFCA, \$FFCB	Modulus Down Counter underflow	I-Bit	MCCTL (MCZI)	\$CA

\$FFC8, \$FFC9	Pulse Accumulator B Overflow	I-Bit	PBCTL(PBOVI)	\$C8
\$FFC6, \$FFC7	CRG PLL lock	I-Bit	CRGINT(LOCKIE)	\$C6
\$FFC4, \$FFC5	CRG Self Clock Mode	I-Bit	CRGINT (SCMIE)	\$C4
\$FFC2, \$FFC3	Reserved			
\$FFC0, \$FFC1	IIC Bus	I-Bit	IBCR (IBIE)	\$C0
\$FFBE, \$FFBF	SPI1	I-Bit	SP1CR1 (SPIE, SPTIE)	\$BE
\$FFBC, \$FFBD	Reserved			
\$FFBA, \$FFBB	EEPROM	I-Bit	EECTL(CCIE, CBEIE)	\$BA
\$FFB8, \$FFB9	FLASH	I-Bit	FCTL(CCIE, CBEIE)	\$B8
\$FF90 to \$FFB7	Reserved			
\$FF8E, \$FF8F	Port P Interrupt	I-Bit	PTPIF (PTPIE)	\$8E
\$FF8C, \$FF8D	PWM Emergency Shutdown	I-Bit	PWMSDN (PWMIE)	\$8C
\$FF80 to \$FF8B	Reserved			

5.3 Effects of Reset

When a reset occurs, MCU registers and control bits are changed to known start-up states. Refer to the respective module Block User Guides for register reset states.

5.3.1 I/O Pins

Refer to the *HCS12 Core User Guide* (Motorola document order number HCS12COREUG/D) for mode dependent pin configuration of port A, B, E and K out of reset.

Refer to the *MC9S12A128 Port Integration Module (PIM) Block Guide* (Motorola document order number, S12A128PIMV1/D) for reset configurations of all peripheral module ports.

NOTE: For devices assembled in 80-pin QFP packages all non-bonded out pins should be configured as outputs after reset in order to avoid current drawn from floating inputs. Refer to [Table 2-1 Signal Properties](#) for affected pins.

5.3.2 Memory

Refer to [Table 1-1 Device Memory Map](#) for locations of the memories depending on the operating mode after reset.

The RAM array is not automatically initialized out of reset.

Section 6 HCS12 Core Block Description

Consult the *HCS12 Core User Guide* (Motorola document order number HCS12COREUG/D) for information about the HCS12 core modules, i.e. central processing unit (CPU), interrupt module (INT), module mapping control module (MMC), multiplexed external bus interface (MEBI), breakpoint module (BKP) and background debug mode module (BDM).

Section 7 Clock and Reset Generator (CRG) Block Description

Consult the *HCS12 Clock and Reset Generator (CRG) Block Guide* (Motorola document order number, S12CRGV3/D) for information about the Clock and Reset Generator module.

7.1 Device-Specific Information

7.1.1 $\overline{\text{XCLKS}}$

The $\overline{\text{XCLKS}}$ input signal is active low (see [2.3.13 PE7 / NOACC / XCLKS — Port E I/O Pin 7](#)).

Refer to Figure 2-3. Pierce Oscillator Connections (XCLKS=1) of the *HCS12 Clock and Reset Generator (CRG) Block Guide* (Motorola document order number, S12CRGV3/D).

Section 8 Enhanced Capture Timer (ECT) Block Description

Consult the *HCS12 16-Bit, 8-Channel Enhanced Capture Timer (ECT) Block Guide* (Motorola document order number, S12ECT16B8CV1/D) for information about the Enhanced Capture Timer module.

Section 9 Analog to Digital Converter (ATD) Block Description

There are two Analog to Digital Converters (ATD1 and ATD0) implemented on the MC9S12A128. Consult the *HCS12 10-Bit, 8-Channel Analog-to-Digital Converter (ATD) Block Guide* (Motorola document order number, S12ATD10B8CV2/D) for information about each Analog to Digital Converter module.

Section 10 Inter-IC Bus (IIC) Block Description

Consult the *HCS12 Inter-Integrated Circuit (IIC) Block Guide* (Motorola document order number, S12IICV2/D) for information about the Inter-IC Bus module.

Section 11 Serial Communications Interface (SCI) Block Description

There are two Serial Communications Interfaces (SCI1 and SCI0) implemented on the MC9S12A128 device. Consult the *HCS12 Serial Communications Interface (SCI) Block Guide* (Motorola document order number, S12SCIV2/D) for information about each Serial Communications Interface module.

Section 12 Serial Peripheral Interface (SPI) Block Description

There are two Serial Peripheral Interfaces (SPI1 and SPI0) implemented on MC9S12A128. Consult the *HCS12 Serial Peripheral Interface (SPI) Block Guide* (Motorola document order number, S12SPIV2/D) for information about each Serial Peripheral Interface module.

Section 13 Pulse Width Modulator (PWM) Block Description

Consult the *HCS12 8-Bit, 8-Channel Pulse Width Modulator (PWM) Block Guide* (Motorola document order number, S12PWM8B8CV1/D) for information about the Pulse Width Modulator module.

Section 14 Flash EEPROM 128K Block Description

Consult the *HCS12 128K FLASH Block Guide* (Motorola document order number, S12FTS128KV1/D) for information about the flash module.

Section 15 EEPROM 2K Block Description

Consult the *HCS12 2K EEPROM Block Guide* (Motorola document order number, S12EETS2KV1/D) for information about the EEPROM module.

Section 16 RAM Block Description

This module supports single-cycle misaligned word accesses.

Section 17 Port Integration Module (PIM) Block Description

Consult the *MC9S12A128 Port Integration Module (PIM) Block Guide* (Motorola document order number, S12A128PIMV1/D) for information about the Port Integration Module.

Section 18 Voltage Regulator (V_{REG}) Block Description

Consult the *HCS12 Voltage Regulator Block Guide* (Motorola document order number, S12VREGV1/D) for information about the dual output linear voltage regulator.

Component	Purpose	Type	Value
C1	V_{DD1} filter cap	ceramic X7R	100 .. 220nF
C2	V_{DD2} filter cap	ceramic X7R	100 .. 220nF
C3	V_{DDA} filter cap	ceramic X7R	100nF
C4	V_{DDR} filter cap	X7R/tantalum	≥ 100 nF
C5	V_{DDPLL} filter cap	ceramic X7R	100nF
C6	V_{DDX} filter cap	X7R/tantalum	≥ 100 nF
C7	OSC load cap		
C8	OSC load cap		
C9	PLL loop filter cap	See A.5.3 Phase Locked Loop	
C10	PLL loop filter cap		
C11	DC cutoff cap		
R1	PLL loop filter res		
Q1	Quartz		

The PCB must be carefully laid out to ensure proper operation of the voltage regulator as well as of the MCU itself. The following rules must be observed:

- Every supply pair must be decoupled by a ceramic capacitor connected as near as possible to the corresponding pins (C1 - C6).
- Central point of the ground star should be the V_{SSR} pin.
- Use low ohmic low inductance connections between V_{SS1} , V_{SS2} and V_{SSR} .
- V_{SSPLL} must be directly connected to V_{SSR} .
- Keep traces of V_{SSPLL} , EXTAL and XTAL as short as possible and occupied board area for C7, C8, C11 and Q1 as small as possible.
- Do not place other signals or supplies underneath area occupied by C7, C8, C10 and Q1 and the connection area to the MCU.
- Central power input should be fed in at the V_{DDA}/V_{SSA} pins.

Figure 18-1 Recommended PCB Layout 112 LQFP

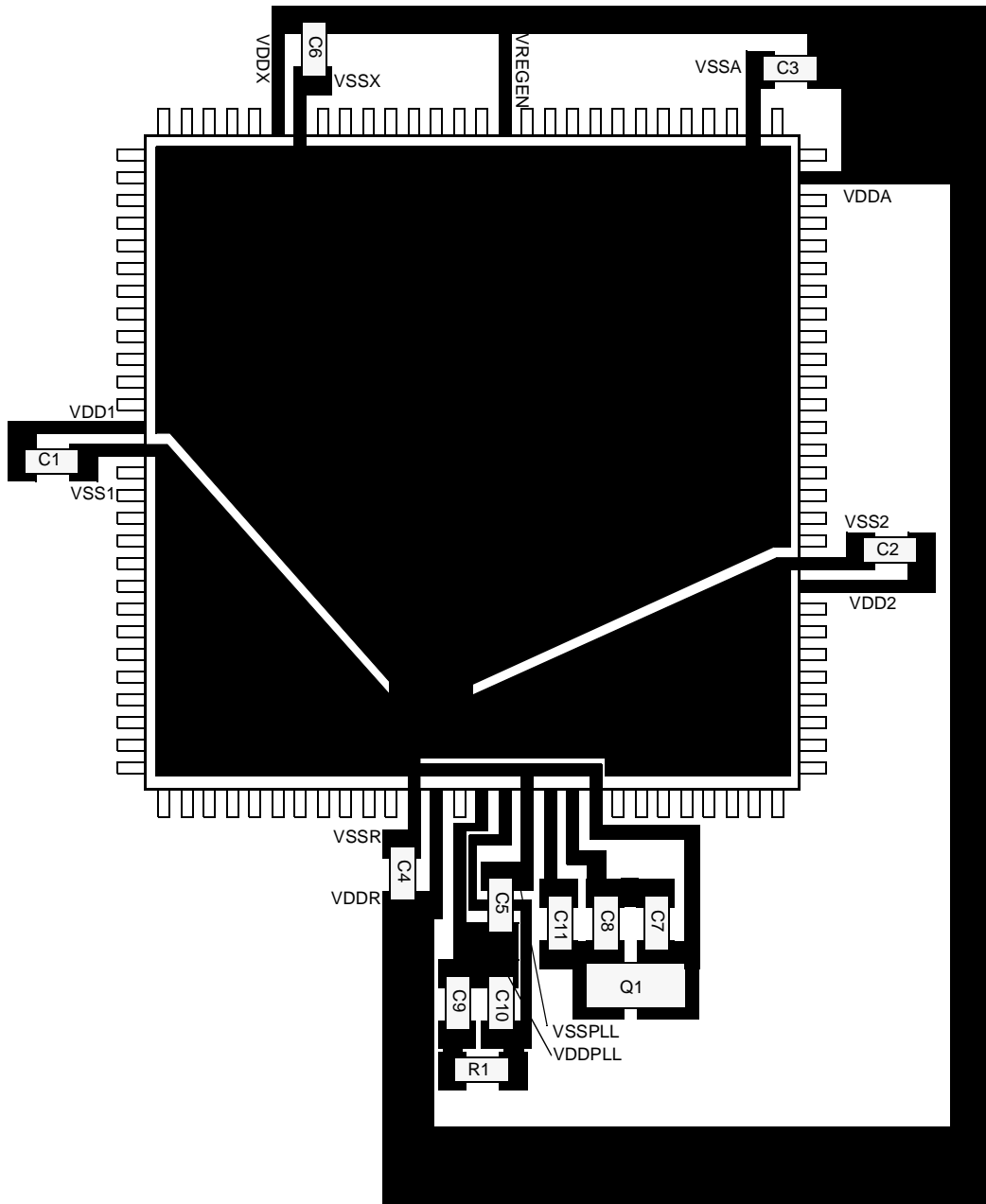
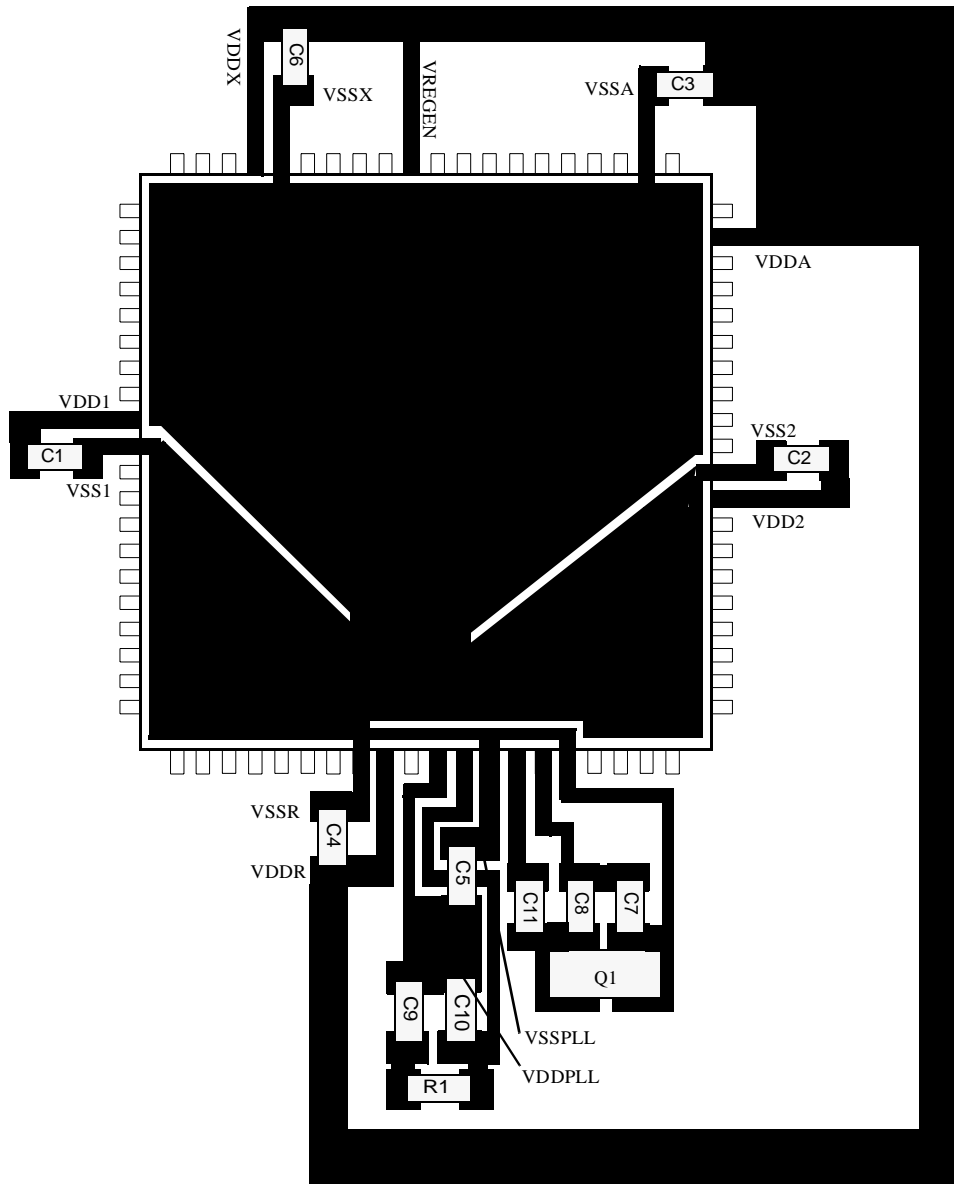

Figure 18-2 Recommended PCB Layout for 80 QFP



Appendix A Electrical Characteristics

A.1 General

NOTE: *The electrical characteristics given in this section are preliminary and should be used as a guide only. Values cannot be guaranteed by Motorola and are subject to change without notice.*

This supplement contains the most accurate electrical information for the MC9S12A128 microcontroller available at the time of publication. The information should be considered **PRELIMINARY** and is subject to change.

This introduction is intended to give an overview on several common topics like power supply, current injection etc.

A.1.1 Parameter Classification

The electrical parameters shown in this supplement are guaranteed by various methods. To give the customer a better understanding the following classification is used and the parameters are tagged accordingly in the tables where appropriate.

NOTE: *This classification is shown in the column labeled “C” in the parameter tables where appropriate.*

P:

Those parameters are guaranteed during production testing on each individual device.

C:

Those parameters are achieved by the design characterization by measuring a statistically relevant sample size across process variations.

T:

Those parameters are achieved by design characterization on a small sample size from typical devices under typical conditions unless otherwise noted. All values shown in the typical column are within this category.

D:

Those parameters are derived mainly from simulations.

A.1.2 Power Supply

The MC9S12A128 utilizes several pins to supply power to the I/O ports, A/D converter, oscillator and PLL as well as the digital core.

The V_{DDA} , V_{SSA} pair supplies the A/D converter and the resistor ladder of the internal voltage regulator.

The V_{DDX} , V_{SSX} , V_{DDR} and V_{SSR} pairs supply the I/O pins, V_{DDR} supplies also the internal voltage regulator.

V_{DD1} , V_{SS1} , V_{DD2} and V_{SS2} are the supply pins for the digital logic, V_{DDPLL} , V_{SSPLL} supply the oscillator and the PLL.

V_{SS1} and V_{SS2} are internally connected by metal.

V_{DDA} , V_{DDX} , V_{DDR} as well as V_{SSA} , V_{SSX} , V_{SSR} are connected by anti-parallel diodes for ESD protection.

NOTE: *In the following context V_{DD5} is used for either V_{DDA} , V_{DDR} and V_{DDX} ; V_{SS5} is used for either V_{SSA} , V_{SSR} and V_{SSX} unless otherwise noted.*

I_{DD5} denotes the sum of the currents flowing into the V_{DDA} , V_{DDX} and V_{DDR} pins.

V_{DD} is used for V_{DD1} , V_{DD2} and V_{DDPLL} , V_{SS} is used for V_{SS1} , V_{SS2} and V_{SSPLL} .

I_{DD} is used for the sum of the currents flowing into V_{DD1} and V_{DD2} .

A.1.3 Pins

There are four groups of functional pins.

A.1.3.1 5V I/O pins

Those I/O pins have a nominal level of 5V. This class of pins is comprised of all port I/O pins, the analog inputs, BKGD and the RESET pins. The internal structure of all those pins is identical, however some of the functionality may be disabled. E.g. for the analog inputs the output drivers, pull-up and pull-down resistors are disabled permanently.

A.1.3.2 Analog Reference

This group is made up by the V_{RH} and V_{RL} pins.

A.1.3.3 Oscillator

The pins XFC, EXTAL, XTAL dedicated to the oscillator have a nominal 2.5V level. They are supplied by V_{DDPLL} .

A.1.3.4 TEST

This pin is used for production testing only.

A.1.3.5 V_{REGEN}

This pin is used to enable the on chip voltage regulator.

A.1.4 Current Injection

Power supply must maintain regulation within operating V_{DD5} or V_{DD} range during instantaneous and operating maximum current conditions. If positive injection current ($V_{in} > V_{DD5}$) is greater than I_{DD5} , the injection current may flow out of V_{DD5} and could result in external power supply going out of regulation. Ensure external V_{DD5} load will shunt current greater than maximum injection current. This will be the greatest risk when the MCU is not consuming power; e.g. if no system clock is present, or if clock rate is very low which would reduce overall power consumption.

A.1.5 Absolute Maximum Ratings

Absolute maximum ratings are stress ratings only. A functional operation under or outside those maxima is not guaranteed. Stress beyond those limits may affect the reliability or cause permanent damage of the device.

This device contains circuitry protecting against damage due to high static voltage or electrical fields; however, it is advised that normal precautions be taken to avoid application of any voltages higher than maximum-rated voltages to this high-impedance circuit. Reliability of operation is enhanced if unused inputs are tied to an appropriate logic voltage level (e.g., either V_{SS5} or V_{DD5}).

Table A-1 Absolute Maximum Ratings⁽¹⁾

Num	Rating	Symbol	Min	Max	Unit
1	I/O, Regulator and Analog Supply Voltage	V_{DD5}	-0.3	6.0	V
2	Digital Logic Supply Voltage ⁽²⁾	V_{DD}	-0.3	3.0	V
3	PLL Supply Voltage ²	V_{DDPLL}	-0.3	3.0	V
4	Voltage difference V_{DDX} to V_{DDR} and V_{DDA}	ΔV_{DDX}	-0.3	0.3	V
5	Voltage difference V_{SSX} to V_{SSR} and V_{SSA}	ΔV_{SSX}	-0.3	0.3	V
6	Digital I/O Input Voltage	V_{IN}	-0.3	6.0	V
7	Analog Reference	V_{RH}, V_{RL}	-0.3	6.0	V
8	XFC, EXTAL, XTAL inputs	V_{ILV}	-0.3	3.0	V
9	TEST input	V_{TEST}	-0.3	10.0	V
10	Instantaneous Maximum Current Single pin limit for all digital I/O pins ⁽³⁾	I_D	-25	+25	mA
11	Instantaneous Maximum Current Single pin limit for XFC, EXTAL, XTAL ⁽⁴⁾	I_{DL}	-25	+25	mA
12	Instantaneous Maximum Current Single pin limit for TEST ⁽⁵⁾	I_{DT}	-0.25	0	mA
13	Storage Temperature Range	T_{stg}	-65	155	°C

NOTES:

- Beyond absolute maximum ratings device might be damaged.
- The device contains an internal voltage regulator to generate the logic and PLL supply out of the I/O supply. The absolute maximum ratings apply when the device is powered from an external source.
- All digital I/O pins are internally clamped to V_{SSX} and V_{DDX} , V_{SSR} and V_{DDR} or V_{SSA} and V_{DDA} .
- Those pins are internally clamped to V_{SSPLL} and V_{DDPLL} .
- This pin is clamped low to V_{SSPLL} , but not clamped high. This pin must be tied low in applications.

A.1.6 ESD Protection and Latch-up Immunity

All ESD testing is in conformity with CDF-AEC-Q100 Stress test qualification for Automotive Grade Integrated Circuits. During the device qualification ESD stresses were performed for the Human Body Model (HBM), the Machine Model (MM) and the Charge Device Model.

A device will be defined as a failure if after exposure to ESD pulses the device no longer meets the device specification. Complete DC parametric and functional testing is performed per the applicable device specification at room temperature followed by hot temperature, unless specified otherwise in the device specification.

Table A-2 ESD and Latch-up Test Conditions

Model	Description	Symbol	Value	Unit
Human Body	Series Resistance	R1	1500	Ohm
	Storage Capacitance	C	100	pF
	Number of Pulse per pin positive negative	— —	3 3	
Machine	Series Resistance	R1	0	Ohm
	Storage Capacitance	C	200	pF
	Number of Pulse per pin positive negative	— —	3 3	
Latch-up	Minimum input voltage limit	—	-2.5	V
	Maximum input voltage limit	—	7.5	V

Table A-3 ESD and Latch-Up Protection Characteristics

Num	C	Rating	Symbol	Min	Max	Unit
1	C	Human Body Model (HBM)	V_{HBM}	2000	—	V
2	C	Machine Model (MM)	V_{MM}	200	—	V
3	C	Charge Device Model (CDM)	V_{CDM}	500	—	V
4	C	Latch-up Current at $T_A = 125^\circ\text{C}$ positive negative	I_{LAT}	+100 -100	— —	mA
5	C	Latch-up Current at $T_A = 27^\circ\text{C}$ positive negative	I_{LAT}	+200 -200	— —	mA

A.1.7 Operating Conditions

This chapter describes the operating conditions of the device. Unless otherwise noted those conditions apply to all the following data.

NOTE: Please refer to the temperature rating of the device (C) with regards to the ambient temperature T_A and the junction temperature T_J . For power dissipation calculations refer to [A.1.8 Power Dissipation and Thermal Characteristics](#).

Table A-4 Operating Conditions

Rating	Symbol	Min	Typ	Max	Unit
I/O, Regulator and Analog Supply Voltage	V_{DD5}	4.5	5	5.25	V
Digital Logic Supply Voltage ⁽¹⁾	V_{DD}	2.35	2.5	2.75	V
PLL Supply Voltage ⁽²⁾	V_{DDPLL}	2.25	2.5	2.75	V
Voltage Difference V_{DDX} to V_{DDR} and V_{DDA}	ΔV_{DDX}	-0.1	0	0.1	V
Voltage Difference V_{SSX} to V_{SSR} and V_{SSA}	ΔV_{SSX}	-0.1	0	0.1	V
Oscillator	f_{osc}	0.5	—	16	MHz
Bus Frequency	f_{bus}	0.5	—	25	MHz
MC9S12A128C					
Operating Junction Temperature Range	T_J	-40	—	100	°C
Operating Ambient Temperature Range ⁽²⁾	T_A	-40	27	85	°C

NOTES:

1. The device contains an internal voltage regulator to generate the logic and PLL supply out of the I/O supply. The absolute maximum ratings apply when this regulator is disabled and the device is powered from an external source.
2. Please refer to [A.1.8 Power Dissipation and Thermal Characteristics](#) for more details about the relation between ambient temperature T_A and device junction temperature T_J .

A.1.8 Power Dissipation and Thermal Characteristics

Power dissipation and thermal characteristics are closely related. The user must assure that the maximum operating junction temperature is not exceeded. The average chip-junction temperature (T_J) in °C can be obtained from:

$$T_J = T_A + (P_D \cdot \Theta_{JA})$$

T_J = Junction Temperature, [°C]

T_A = Ambient Temperature, [°C]

P_D = Total Chip Power Dissipation, [W]

Θ_{JA} = Package Thermal Resistance, [°C/W]

The total power dissipation can be calculated from:

$$P_D = P_{INT} + P_{IO}$$

P_{INT} = Chip Internal Power Dissipation, [W]

Two cases with internal voltage regulator enabled and disabled must be considered:

1. Internal Voltage Regulator disabled

$$P_{INT} = I_{DD} \cdot V_{DD} + I_{DDPLL} \cdot V_{DDPLL} + I_{DDA} \cdot V_{DDA}$$

$$P_{IO} = \sum_i R_{DSON} \cdot I_{IO_i}^2$$

P_{IO} is the sum of all output currents on I/O ports associated with V_{DDX} and V_{DDR} .

For R_{DSON} is valid:

$$R_{DSON} = \frac{V_{OL}}{I_{OL}}; \text{for outputs driven low}$$

respectively

$$R_{DSON} = \frac{V_{DD5} - V_{OH}}{I_{OH}}; \text{for outputs driven high}$$

2. Internal voltage regulator enabled

$$P_{INT} = I_{DDR} \cdot V_{DDR} + I_{DDA} \cdot V_{DDA}$$

I_{DDR} is the current shown in [Table A-7](#) and not the overall current flowing into V_{DDR} , which additionally contains the current flowing into the external loads with output high.

$$P_{IO} = \sum_i R_{DSON} \cdot I_{IO_i}^2$$

P_{IO} is the sum of all output currents on I/O ports associated with V_{DDX} and V_{DDR} .

Table A-5 Thermal Package Characteristics⁽¹⁾

Num	C	Rating	Symbol	Min	Typ	Max	Unit
1	T	Thermal Resistance LQFP112, single sided PCB ⁽²⁾	θ_{JA}	—	—	54	°C/W
2	T	Thermal Resistance LQFP112, double sided PCB with 2 internal planes ⁽³⁾	θ_{JA}	—	—	41	°C/W
3	T	Thermal Resistance LQFP 80, single sided PCB	θ_{JA}	—	—	51	°C/W
4	T	Thermal Resistance LQFP 80, double sided PCB with 2 internal planes	θ_{JA}	—	—	41	°C/W

NOTES:

1. The values for thermal resistance are achieved by package simulations
2. PC Board according to EIA/JEDEC Standard 51-2
3. PC Board according to EIA/JEDEC Standard 51-7

A.1.9 I/O Characteristics

This section describes the characteristics of all 5V I/O pins. All parameters are not always applicable, e.g. not all pins feature pull up/down resistances.

Table A-6 5V I/O Characteristics

Conditions are shown in Table A-4 unless otherwise noted							
Num	C	Rating	Symbol	Min	Typ	Max	Unit
1	P	Input High Voltage	V_{IH}	$0.65 \cdot V_{DD5}$	—	—	V
	T	Input High Voltage	V_{IH}	—	—	$V_{DD5} + 0.3$	V
2	P	Input Low Voltage	V_{IL}	—	—	$0.35 \cdot V_{DD5}$	V
	T	Input Low Voltage	V_{IL}	$V_{SS5} - 0.3$	—	—	V
3	C	Input Hysteresis	V_{HYS}	—	250	—	mV
4	P	Input Leakage Current (pins in high impedance input mode) ⁽¹⁾ $V_{in} = V_{DD5}$ or V_{SS5}	I_{in}	-2.5	—	2.5	μ A
5	P	Output High Voltage (pins in output mode) Partial Drive $I_{OH} = -2.0$ mA Full Drive $I_{OH} = -10.0$ mA	V_{OH}	$V_{DD5} - 0.8$	—	—	V
6	P	Output Low Voltage (pins in output mode) Partial Drive $I_{OL} = +2.0$ mA Full Drive $I_{OL} = +10.0$ mA	V_{OL}	—	—	0.8	V
7	P	Internal Pull Up Device Current, tested at V_{IL} Max.	I_{PUL}	—	—	-130	μ A
8	P	Internal Pull Up Device Current, tested at V_{IH} Min.	I_{PUH}	-10	—	—	μ A
9	P	Internal Pull Down Device Current, tested at V_{IH} Min.	I_{PDH}	—	—	130	μ A
10	P	Internal Pull Down Device Current, tested at V_{IL} Max.	I_{PDL}	10	—	—	μ A
11	D	Input Capacitance	C_{in}	—	6	—	pF
12	T	Injection current ⁽²⁾ Single Pin limit Total Device Limit. Sum of all injected currents	I_{ICS} I_{ICP}	-2.5 -25	—	2.5 25	mA
13	P	Port H, J, P Interrupt Input Pulse filtered ⁽³⁾	t_{PULSE}	—	—	3	μ s
14	P	Port H, J, P Interrupt Input Pulse passed ⁽³⁾	t_{PULSE}	10	—	—	μ s

NOTES:

- Maximum leakage current occurs at maximum operating temperature. Current decreases by approximately one-half for each 8°C to 12°C in the temperature range from 50°C to 125°C.
- Refer to [A.1.4 Current Injection](#), for more details
- Parameter only applies in STOP or Pseudo STOP mode.

A.1.10 Supply Currents

This section describes the current consumption characteristics of the device as well as the conditions for the measurements.

A.1.10.1 Measurement Conditions

All measurements are without output loads. Unless otherwise noted the currents are measured in single chip mode, internal voltage regulator enabled and at 25MHz bus frequency using a 4MHz oscillator in Colpitts mode. Production testing is performed using a square wave signal at the EXTAL input.

A.1.10.2 Additional Remarks

In expanded modes the currents flowing in the system are highly dependent on the load at the address, data and control signals as well as on the duty cycle of those signals. No generally applicable numbers can be given. A very good estimate is to take the single chip currents and add the currents due to the external loads.

Table A-7 Supply Current Characteristics

Conditions are shown in Table A-4 unless otherwise noted							
Num	C	Rating	Symbol	Min	Typ	Max	Unit
1	P	Run supply currents Single Chip, Internal regulator enabled	I_{DD5}	—	—	65	mA
2	P P	Wait Supply current All modules enabled, PLL on only RTI enabled ⁽¹⁾	I_{DDW}	— —	— —	40 5	mA
3	C P C C P C	Pseudo Stop Current (RTI and COP disabled) ^{(1), (2)} —40°C 27°C 70°C 85°C “C” Temp Option 100°C 105°C	I_{DDPS}	— — — — — —	370 400 450 550 600 650	500 1600	μA
4	C C C C C	Pseudo Stop Current (RTI and COP enabled) ^{(1), (2)} —40°C 27°C 70°C 85°C 105°C	I_{DDPS}	— — — — — —	570 600 650 750 850	— — — — —	μA
5	C P C C P C	Stop Current ⁽²⁾ —40°C 27°C 70°C 85°C “C” Temp Option 100°C 105°C	I_{DDS}	— — — — — —	12 25 100 130 160 200	100 1200	μA

NOTES:

1. PLL off
2. At those low power dissipation levels $T_J = T_A$ can be assumed

A.2 ATD Characteristics

This section describes the characteristics of the analog to digital converter.

A.2.1 ATD Operating Characteristics

The [Table A-8](#) shows conditions under which the ATD operates.

The following constraints exist to obtain full-scale, full range results:

$V_{SSA} \leq V_{RL} \leq V_{IN} \leq V_{RH} \leq V_{DDA}$. This constraint exists since the sample buffer amplifier can not drive beyond the power supply levels that it ties to. If the input level goes outside of this range it will effectively be clipped.

Table A-8 ATD Operating Characteristics

Conditions are shown in Table A-4 unless otherwise noted								
Num	C	Rating	Symbol	Min	Typ	Max	Unit	
1	D	Reference Potential	Low	V_{RL}	V_{SSA}	—	$V_{DDA}/2$	V
			High	V_{RH}	$V_{DDA}/2$	—	V_{DDA}	V
2	C	Differential Reference Voltage ⁽¹⁾	$V_{RH}-V_{RL}$	4.50	5.00	5.25	V	
3	D	ATD Clock Frequency	f_{ATDCLK}	0.5	—	2.0	MHz	
4	D	ATD 10-Bit Conversion Period	Clock Cycles ⁽²⁾	N_{CONV10}	14	—	28	Cycles
			Conv, Time at 2.0MHz ATD Clock f_{ATDCLK}	T_{CONV10}	7	—	14	μs
5	D	ATD 8-Bit Conversion Period	Clock Cycles ⁽²⁾	N_{CONV8}	12	—	26	Cycles
			Conv, Time at 2.0MHz ATD Clock f_{ATDCLK}	T_{CONV8}	6	—	13	μs
6	D	Stop Recovery Time ($V_{DDA}=5.0$ Volts)	t_{SR}	—	—	20	μs	
7	P	Reference Supply current (Both ATD blocks on)	I_{REF}	—	—	0.750	mA	
8	P	Reference Supply current (Only one ATD block on)	I_{REF}	—	—	0.375	mA	

NOTES:

1. Full accuracy is not guaranteed when differential voltage is less than 4.50V
2. The minimum time assumes a final sample period of 2 ATD clocks cycles while the maximum time assumes a final sample period of 16 ATD clocks.

A.2.2 Factors Influencing accuracy

Three factors — source resistance, source capacitance and current injection — have an influence on the accuracy of the ATD.

A.2.2.1 Source Resistance

Due to the input pin leakage current as specified in [Table A-6](#) in conjunction with the source resistance there will be a voltage drop from the signal source to the ATD input. The maximum source resistance R_S

specifies results in an error of less than 1/2 LSB (2.5mV) at the maximum leakage current. If device or operating conditions are less than worst case or leakage-induced error is acceptable, larger values of source resistance is allowed.

A.2.2.2 Source Capacitance

When sampling an additional internal capacitor is switched to the input. This can cause a voltage drop due to charge sharing with the external and the pin capacitance. For a maximum sampling error of the input voltage $\leq 1\text{LSB}$, then the external filter capacitor, $C_f \geq 1024 * (C_{INS} - C_{INN})$.

A.2.2.3 Current Injection

There are two cases to consider.

1. A current is injected into the channel being converted. The channel being stressed has conversion values of \$3FF (\$FF in 8-bit mode) for analog inputs greater than V_{RH} and \$000 for values less than V_{RL} unless the current is higher than specified as disruptive condition.
2. Current is injected into pins in the neighborhood of the channel being converted. A portion of this current is picked up by the channel (coupling ratio K), This additional current impacts the accuracy of the conversion depending on the source resistance.

The additional input voltage error on the converted channel can be calculated as $V_{ERR} = K * R_S * I_{INJ}$, with I_{INJ} being the sum of the currents injected into the two pins adjacent to the converted channel.

Table A-9 ATD Electrical Characteristics

Conditions are shown in Table A-4 unless otherwise noted							
Num	C	Rating	Symbol	Min	Typ	Max	Unit
1	C	Max input Source Resistance	R_S	—	—	1	$K\Omega$
2	T	Total Input Capacitance	C_{INN}	—	—	10	pF
		Non Sampling Sampling	C_{INS}	—	—	22	
3	C	Disruptive Analog Input Current	I_{NA}	-2.5	—	2.5	mA
4	C	Coupling Ratio positive current injection	K_p	—	—	10^{-4}	A/A
5	C	Coupling Ratio negative current injection	K_n	—	—	10^{-2}	A/A

A.2.3 ATD Accuracy

Table A-10 specifies the ATD conversion performance excluding any errors due to current injection, input capacitance and source resistance.

Table A-10 ATD Conversion Performance

Conditions are shown in Table A-4 unless otherwise noted $V_{REF} = V_{RH} - V_{RL} = 5.12V$. Resulting to one 8 bit count = 20mV and one 10 bit count = 5mV $f_{ATDCLK} = 2.0MHz$							
Num	C	Rating	Symbol	Min	Typ	Max	Unit
1	P	10-Bit Resolution	LSB	—	5	—	mV
2	P	10-Bit Differential Nonlinearity	DNL	-1		1	Counts
3	P	10-Bit Integral Nonlinearity	INL	-2.5	±1.5	2.5	Counts
4	P	10-Bit Absolute Error ⁽¹⁾	AE	-3	±2.0	3	Counts
5	P	8-Bit Resolution	LSB	—	20	—	mV
6	P	8-Bit Differential Nonlinearity	DNL	-0.5	—	0.5	Counts
7	P	8-Bit Integral Nonlinearity	INL	-1.0	±0.5	1.0	Counts
8	P	8-Bit Absolute Error ⁽¹⁾	AE	-1.5	±1.0	1.5	Counts

NOTES:

1. These values include the quantization error which is inherently 1/2 count for any A/D converter.

For the following definitions see also [Figure A-1](#).

Differential Non-Linearity (DNL) is defined as the difference between two adjacent switching steps.

$$DNL(i) = \frac{V_i - V_{i-1}}{1LSB} - 1$$

The Integral Non-Linearity (INL) is defined as the sum of all DNLs:

$$INL(n) = \sum_{i=1}^n DNL(i) = \frac{V_n - V_0}{1LSB} - n$$

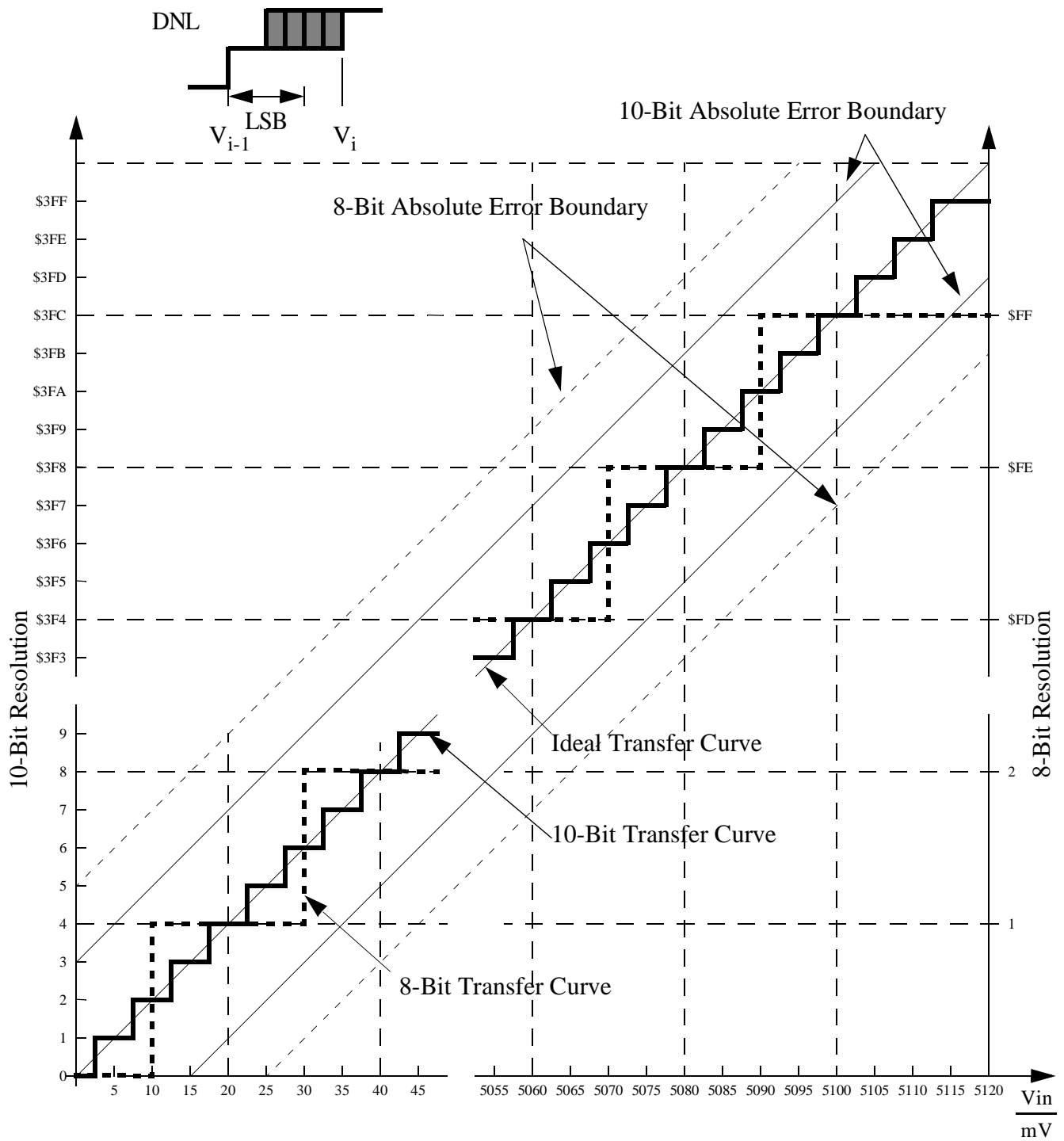

Figure A-1 ATD Accuracy Definitions

NOTE: [Figure A-1](#) shows only definitions, for specification values refer to [Table A-10](#).

A.3 NVM, Flash, and EEPROM

NOTE: Unless otherwise noted the abbreviation *NVM* (Non Volatile Memory) is used for both *Flash* and *EEPROM*.

A.3.1 NVM Timing

The time base for all NVM program or erase operations is derived from the oscillator. A minimum oscillator frequency f_{NVMOSC} is required for performing program or erase operations. The NVM modules do not have any means to monitor the frequency and will not prevent program or erase operation at frequencies above or below the specified minimum. Attempting to program or erase the NVM modules at a lower frequency a full program or erase transition is not assured.

The Flash and EEPROM program and erase operations are timed using a clock derived from the oscillator using the FCLKDIV and ECLKDIV registers respectively. The frequency of this clock must be set within the limits specified as f_{NVMOP} .

The minimum program and erase times shown in [Table A-11](#) are calculated for maximum f_{NVMOP} and maximum f_{bus} . The maximum times are calculated for minimum f_{NVMOP} and a f_{bus} of 2MHz.

A.3.1.1 Single Word Programming

The programming time for single word programming is dependant on the bus frequency as a well as on the frequency f_{NVMOP} and can be calculated according to the following formula.

$$t_{\text{swpgm}} = 9 \cdot \frac{1}{f_{\text{NVMOP}}} + 25 \cdot \frac{1}{f_{\text{bus}}}$$

A.3.1.2 Burst Programming

This applies only to the Flash where up to 32 words in a row can be programmed consecutively using burst programming by keeping the command pipeline filled. The time to program a consecutive word can be calculated as:

$$t_{\text{bwpgm}} = 4 \cdot \frac{1}{f_{\text{NVMOP}}} + 9 \cdot \frac{1}{f_{\text{bus}}}$$

The time to program a whole row is:

$$t_{\text{brpgm}} = t_{\text{swpgm}} + 31 \cdot t_{\text{bwpgm}}$$

Burst programming is more than 2 times faster than single word programming.

A.3.1.3 Sector Erase

Erasing a 512 byte Flash sector or a 4 byte EEPROM sector takes:

$$t_{\text{era}} \approx 4000 \cdot \frac{1}{f_{\text{NVMOP}}}$$

The setup time can be ignored for this operation.

A.3.1.4 Mass Erase

Erasing a NVM block takes:

$$t_{\text{mass}} \approx 20000 \cdot \frac{1}{f_{\text{NVMOP}}}$$

The setup time can be ignored for this operation.

A.3.1.5 Blank Check

The time it takes to perform a blank check on the Flash or EEPROM is dependant on the location of the first non-blank word starting at relative address zero. It takes one bus cycle per word to verify plus a setup of the command.

$$t_{\text{check}} \approx \text{location} \cdot t_{\text{cyc}} + 10 \cdot t_{\text{cyc}}$$

Table A-11 NVM Timing Characteristics

Conditions are shown in Table A-4 unless otherwise noted							
Num	C	Rating	Symbol	Min	Typ	Max	Unit
1	D	External Oscillator Clock	f_{NVMOSC}	0.5	—	50 ⁽¹⁾	MHz
2	D	Bus frequency for Programming or Erase Operations	f_{NVMBUS}	1	—		MHz
3	D	Operating Frequency	f_{NVMOP}	150	—	200	kHz
4	P	Single Word Programming Time	t_{swpgm}	46 ⁽²⁾	—	74.5 ⁽³⁾	μs
5	D	Flash Burst Programming consecutive word ⁽⁴⁾	t_{bwpgm}	20.4 ⁽²⁾	—	31 ⁽³⁾	μs
6	D	Flash Burst Programming Time for 32 Words ⁴	t_{brpgm}	678.4 ⁽²⁾	—	1035.5 ⁽³⁾	μs
7	P	Sector Erase Time	t_{era}	20 ⁽⁵⁾	—	26.7 ⁽³⁾	ms
8	P	Mass Erase Time	t_{mass}	100 ⁽⁵⁾	—	133 ⁽³⁾	ms
9	D	Blank Check Time Flash per block	t_{check}	11 ⁽⁶⁾	—	32,778 ⁽⁷⁾	t_{cyc}
10	D	Blank Check Time EEPROM per block	t_{check}	11 ⁽⁶⁾	—	2058 ⁽⁷⁾	t_{cyc}

NOTES:

- Restrictions for oscillator in crystal mode apply!
- Minimum Programming times are achieved under maximum NVM operating frequency f_{NVMOP} and maximum bus frequency f_{bus} .
- Maximum Erase and Programming times are achieved under particular combinations of f_{NVMOP} and bus frequency f_{bus} . Refer to formulae in [A.3.1.1 Single Word Programming- A.3.1.4 Mass Erase](#) for guidance.
- urst Programming operations are not applicable to EEPROM
- Minimum Erase times are achieved under maximum NVM operating frequency f_{NVMOP} .
- Minimum time, if first word in the array is not blank
- Maximum time to complete check on an erased block

A.3.2 NVM Reliability

The reliability of the NVM blocks is guaranteed by stress test during qualification, constant process monitors and burn-in to screen early life failures.

The failure rates for data retention and program/erase cycling are specified at the operating conditions noted.

The program/erase cycle count on the sector is incremented every time a sector or mass erase event is executed.

NOTE: All values shown in [Table A-12](#) are target values and subject to further extensive characterization.

Table A-12 NVM Reliability Characteristics

Conditions are shown in Table A-4 unless otherwise noted				
Num	C	NVM Array	Cycles	Data Retention Lifetime
1	C	Flash/EEPROM (–40 to + 85°C)	1000	10 years
2	C	EEPROM (–40 to + 85°C)	10,000	10 years

NOTE: Flash cycling performance is 1000 cycles at –40 to +85°C. Data Retention is specified for 10 years.

NOTE: EEPROM cycling performance is 10,000 cycles at –40 to +85°C. Data retention is specified for 10 years.

NOTE: These figures are provided for commercial quality levels not automotive.

A.4 Voltage Regulator

The on-chip voltage regulator is intended to supply the internal logic and oscillator circuits. No external DC load is allowed.

Table A-13 Voltage Regulator Recommended Load Capacitances

Rating	Symbol	Min	Typ	Max	Unit
Load Capacitance on $V_{DD1,2}$	C_{LVDD}	—	220	—	nF
Load Capacitance on V_{DDPLL}	$C_{LVDDPLL}$	—	220	—	nF

A.5 Reset, Oscillator and PLL

This section summarizes the electrical characteristics of the various startup scenarios for Oscillator and Phase-Locked-Loop (PLL).

A.5.1 Startup

Table A-14 summarizes several startup characteristics explained in this section. Detailed description of the startup behavior can be found in the *HCS12 Clock and Reset Generator (CRG) Block Guide* (Motorola document order number, S12CRGV3/D).

Table A-14 Startup Characteristics

Conditions are shown in Table A-4 unless otherwise noted							
Num	C	Rating	Symbol	Min	Typ	Max	Unit
1	T	POR release level	V_{PORR}	—	—	2.07	V
2	T	POR assert level	V_{PORA}	0.97	—	—	V
3	D	Reset input pulse width, minimum input time	PW_{RSTL}	2	—	—	t_{osc}
4	D	Startup from Reset	n_{RST}	192	—	196	n_{osc}
5	D	Interrupt pulse width, \overline{IRQ} edge-sensitive mode	PW_{IRQ}	20	—	—	ns
6	D	Wait recovery startup time	t_{WRS}	—	—	14	t_{cyc}

A.5.1.1 POR

The release level V_{PORR} and the assert level V_{PORA} are derived from the V_{DD} supply. They are also valid if the device is powered externally. After releasing the POR reset the oscillator and the clock quality check are started. If after a time t_{CQOUT} no valid oscillation is detected, the MCU will start using the internal self clock. The fastest startup time possible is given by n_{uposc} .

A.5.1.2 SRAM Data Retention

Provided an appropriate external reset signal is applied to the MCU, preventing the CPU from executing code when V_{DD5} is out of specification limits, the SRAM contents integrity is guaranteed if after the reset the PORF bit in the CRG Flags Register has not been set.

A.5.1.3 External Reset

When external reset is asserted for a time greater than PW_{RSTL} the CRG module generates an internal reset, and the CPU starts fetching the reset vector without doing a clock quality check, if there was an oscillation before reset.

A.5.1.4 Stop Recovery

Out of STOP the controller can be woken up by an external interrupt. A clock quality check as after POR is performed before releasing the clocks to the system.

A.5.1.5 Pseudo Stop and Wait Recovery

The recovery from Pseudo STOP and Wait are essentially the same since the oscillator was not stopped in both modes. The controller can be woken up by internal or external interrupts. After t_{WRS} the CPU starts fetching the interrupt vector.

A.5.2 Oscillator

The device features an internal Colpitts oscillator. By asserting the \overline{XCLKS} input during reset this oscillator can be bypassed allowing the input of a square wave. Before asserting the oscillator to the internal system clocks the quality of the oscillation is checked for each start from either power-on, STOP or oscillator fail. t_{CQOUT} specifies the maximum time before switching to the internal self clock mode after POR or STOP if a proper oscillation is not detected. The quality check also determines the minimum oscillator start-up time t_{UPOSC} . The device also features a clock monitor. A Clock Monitor Failure is asserted if the frequency of the incoming clock signal is below the Assert Frequency f_{CMFA} .

Table A-15 Oscillator Characteristics

Conditions are shown in Table A-4 unless otherwise noted							
Num	C	Rating	Symbol	Min	Typ	Max	Unit
1	C	Crystal oscillator range	f_{OSC}	0.5	—	16	MHz
2	P	Startup Current	I_{OSC}	100	—	—	μA
3	D	Oscillator start-up time from POR or STOP	t_{UPOSC}	4100	—	—	cyc_{OSC}
4	C	Oscillator start-up time	t_{UPOSC}	—	$g^{(1)}$	$100^{(2)}$	ms
5	D	Clock Quality check time-out	t_{CQOUT}	0.45	—	2.5	s
6	P	Clock Monitor Failure Assert Frequency	f_{CMFA}	50	100	200	KHz
7	P	External square wave input frequency ⁽³⁾	f_{EXT}	0.5	—	50	MHz
8	D	External square wave pulse width low	t_{EXTL}	9.5	—	—	ns
9	D	External square wave pulse width high	t_{EXTH}	9.5	—	—	ns
10	D	External square wave rise time	t_{EXTR}	—	—	1	ns
11	D	External square wave fall time	t_{EXTF}	—	—	1	ns
12	D	Input Capacitance (EXTAL, XTAL pins)	C_{IN}	—	9	—	pF
13	C	DC Operating Bias in Colpitts Configuration on EXTAL Pin	V_{DCBIAS}	—	1.1	—	V

NOTES:

- $f_{osc} = 4\text{MHz}$, $C = 22\text{pF}$.
- Maximum value is for extreme cases using high Q, low frequency crystals
- $XCLKS = 0$ during reset

A.5.3 Phase Locked Loop

The oscillator provides the reference clock for the PLL. The PLL's Voltage Controlled Oscillator (VCO) is also the system clock source in self clock mode.

A.5.3.1 XFC Component Selection

This section describes the selection of the XFC components to achieve a good filter characteristics.

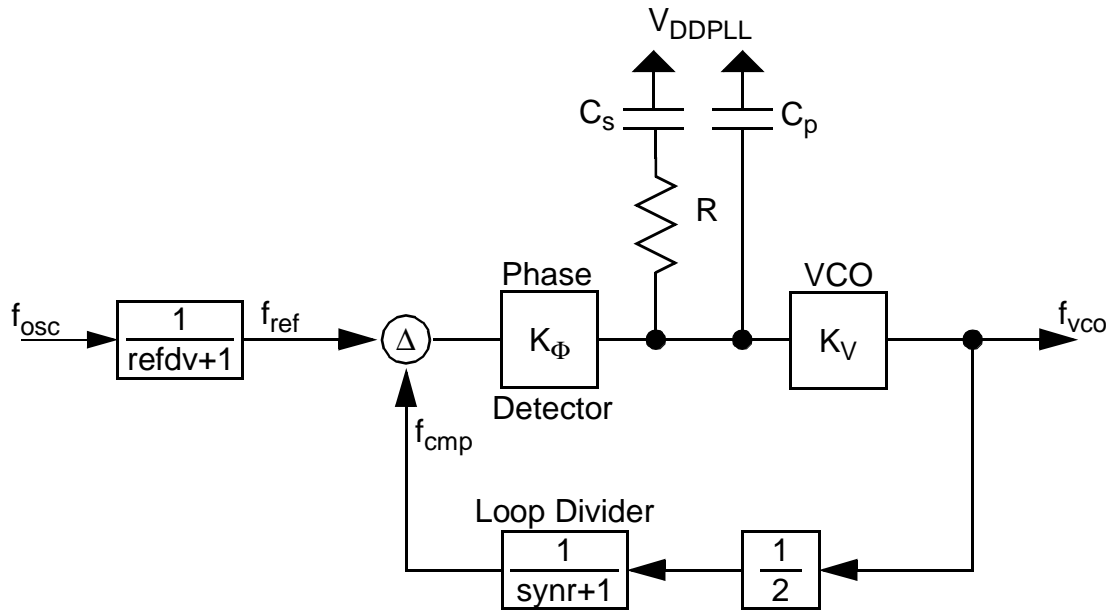

Figure A-2 Basic PLL Functional Diagram

The following procedure can be used to calculate the resistance and capacitance values using typical values for K_1 , f_1 and i_{ch} from [Table A-16](#).

The VCO Gain at the desired VCO output frequency is approximated by:

$$K_V = K_1 \cdot e^{\frac{(T_1 - T_{VCO})}{K_1 \cdot 1V}}$$

The phase detector relationship is given by:

$$K_\Phi = -|i_{ch}| \cdot K_V$$

i_{ch} is the current in tracking mode.

The loop bandwidth f_C should be chosen to fulfill the Gardner's stability criteria by at least a factor of 10, typical values are 50. $\zeta = 0.9$ ensures a good transient response.

$$f_C < \frac{2 \cdot \zeta \cdot f_{\text{ref}}}{\pi \cdot (\zeta + \sqrt{1 + \zeta^2})} \cdot \frac{1}{50} \rightarrow f_C < \frac{f_{\text{ref}}}{4 \cdot 50}; (\zeta = 0.9)$$

And finally the frequency relationship is defined as

$$n = \frac{f_{\text{VCO}}}{f_{\text{ref}}} = 2 \cdot (\text{synr} + 1)$$

With the above inputs the resistance can be calculated as:

$$R = \frac{2 \cdot \pi \cdot n \cdot f_C}{K_{\Phi}}$$

The capacitance C_s can now be calculated as:

$$C_s = \frac{2 \cdot \zeta^2}{\pi \cdot f_C \cdot R} \approx \frac{0.516}{f_C \cdot R}; (\zeta = 0.9)$$

The capacitance C_p should be chosen in the range of:

$$C_s / 20 \leq C_p \leq C_s / 10$$

The stabilization delays shown in [Table A-16](#) are dependant on PLL operational settings and external component selection (e.g. crystal, XFC filter).

A.5.3.2 Jitter Information

The basic functionality of the PLL is shown in [Figure A-2](#). With each transition of the clock f_{cmp} , the deviation from the reference clock f_{ref} is measured and input voltage to the VCO is adjusted accordingly. The adjustment is done continuously with no abrupt changes in the clock output frequency. Noise, voltage, temperature and other factors cause slight variations in the control loop resulting in a clock jitter. This jitter affects the real minimum and maximum clock periods as illustrated in [Figure A-3](#).

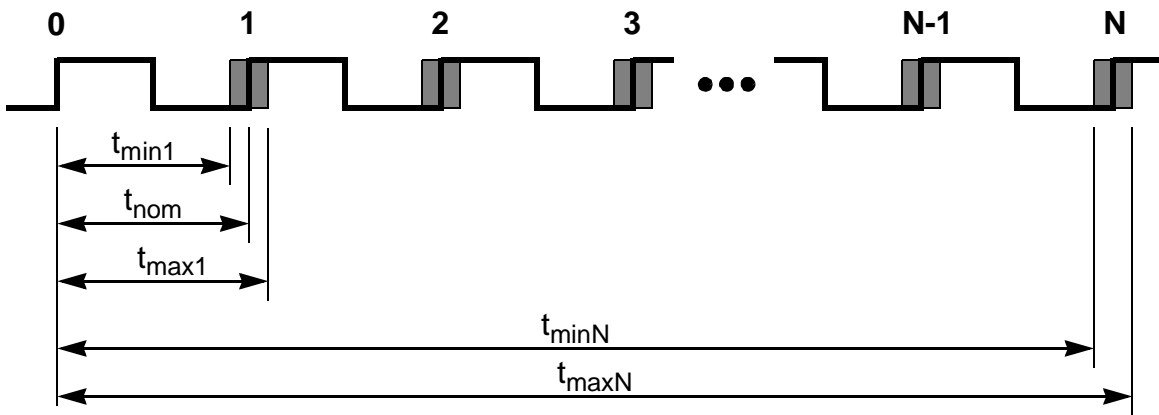

Figure A-3 Jitter Definitions

The relative deviation of t_{nom} is at its maximum for one clock period, and decreases towards zero for larger number of clock periods (N).

Defining the jitter as:

$$J(N) = \max\left(\left|1 - \frac{t_{max}^{(N)}}{N \cdot t_{nom}}\right|, \left|1 - \frac{t_{min}^{(N)}}{N \cdot t_{nom}}\right|\right)$$

For $N < 100$, the following equation is a good fit for the maximum jitter:

$$J(N) = \frac{j_1}{\sqrt{N}} + j_2$$

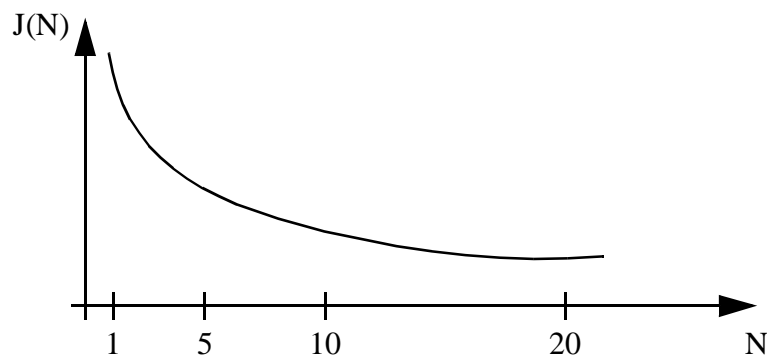

Figure A-4 Maximum Bus Clock Jitter Approximation

This is very important to notice with respect to timers, serial modules where a pre-scaler will eliminate the effect of the jitter to a large extent.

Table A-16 PLL Characteristics

Conditions are shown in Table A-4 unless otherwise noted							
Num	C	Rating	Symbol	Min	Typ	Max	Unit
1	P	Self Clock Mode frequency	f_{SCM}	1	—	5.5	MHz
2	D	VCO locking range	f_{VCO}	8	—	50	MHz
3	D	Lock Detector transition from Acquisition to Tracking mode	$ \Delta_{trk} $	3	—	4	% ⁽¹⁾
4	D	Lock Detection	$ \Delta_{Lock} $	0	—	1.5	% ⁽¹⁾
5	D	Un-Lock Detection	$ \Delta_{unl} $	0.5	—	2.5	% ⁽¹⁾
6	D	Lock Detector transition from Tracking to Acquisition mode	$ \Delta_{unt} $	6	—	8	% ⁽¹⁾
7	C	PLLON Total Stabilization delay (Auto Mode) ⁽²⁾	t_{stab}	—	0.5	—	ms
8	D	PLLON Acquisition mode stabilization delay ⁽²⁾	t_{acq}	—	0.3	—	ms
9	D	PLLON Tracking mode stabilization delay ⁽²⁾	t_{al}	—	0.2	—	ms
10	D	Fitting parameter VCO loop gain	K_1	—	-120	—	MHz/V
11	D	Fitting parameter VCO loop frequency	f_1	—	75	—	MHz
12	D	Charge pump current acquisition mode	$ i_{ch} $	—	38.5	—	μ A
13	D	Charge pump current tracking mode	$ i_{ch} $	—	3.5	—	μ A
14	C	Jitter fit parameter 1 ⁽²⁾	j_1	—	—	1.1	%
15	C	Jitter fit parameter 2 ⁽²⁾	j_2	—	—	0.13	%

NOTES:

1. % deviation from target frequency
2. $f_{REF} = 4\text{MHz}$, $f_{BUS} = 25\text{MHz}$ equivalent $f_{VCO} = 50\text{MHz}$: $REFDV = \#03$, $SYNR = \#018$, $C_s = 4.7\text{nF}$, $C_p = 470\text{pF}$, $R_s = 10\text{K}\Omega$.

A.6 SPI

A.6.1 Master Mode

Figure A-5 and Figure A-6 illustrate the master mode timing. Timing values are shown in Table A-17.

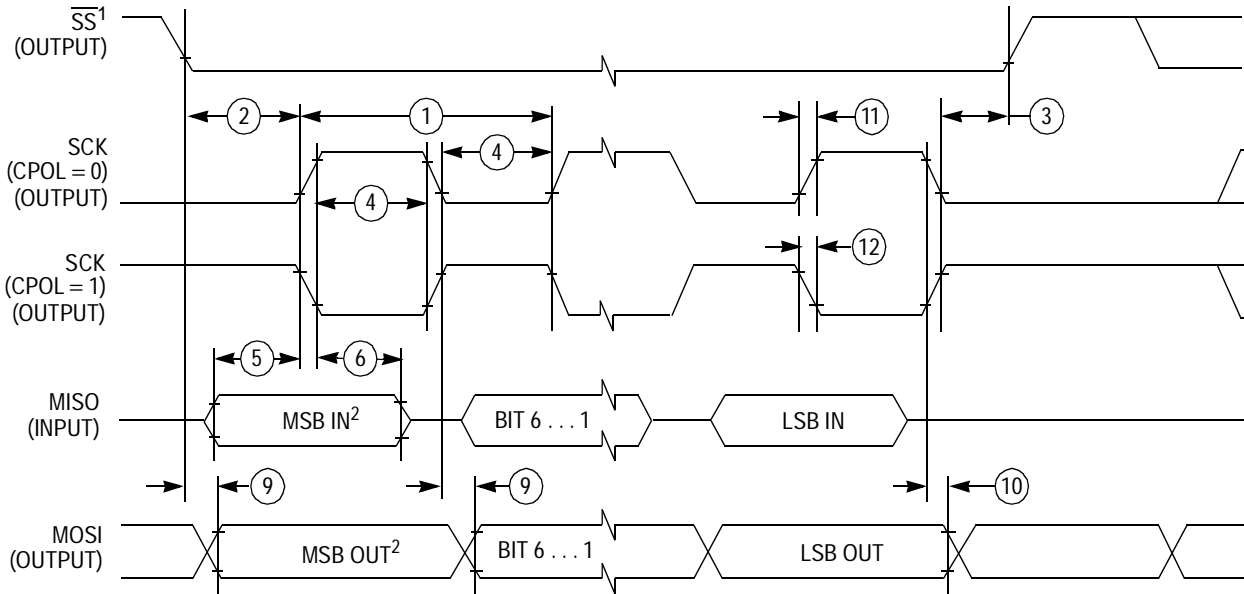

- 1. If configured as output.
- 2. LSBF = 0. For LSBF = 1, bit order is LSB, bit 1, ..., bit 6, MSB.

Figure A-5 SPI Master Timing (CPHA = 0)

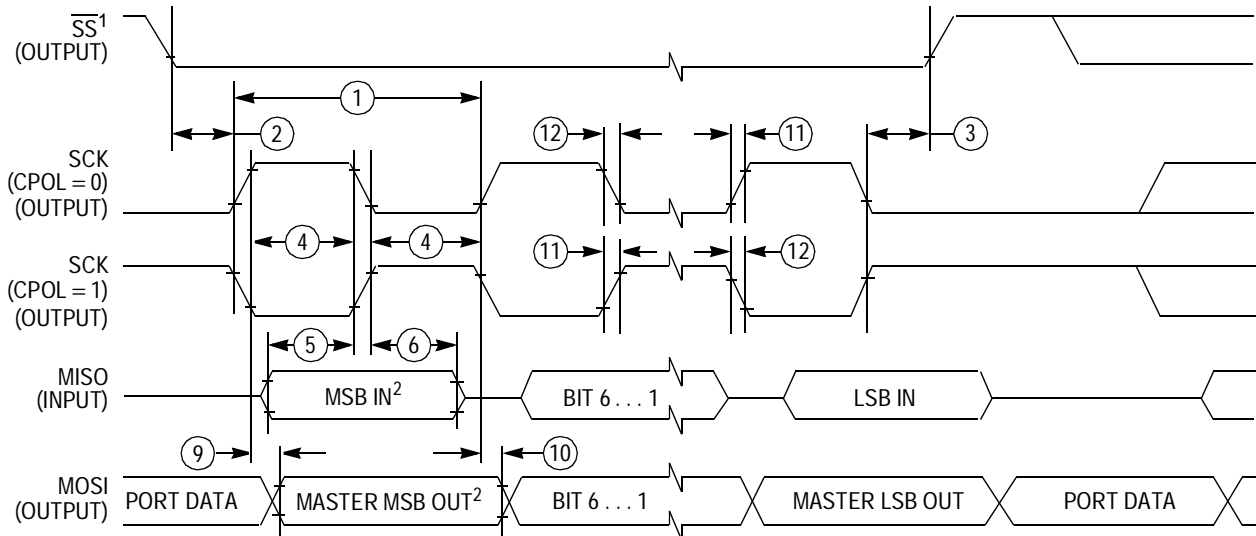

- 1. If configured as output
- 2. LSBF = 0. For LSBF = 1, bit order is LSB, bit 1, ..., bit 6, MSB.

Figure A-6 SPI Master Timing (CPHA =1)

Table A-17 SPI Master Mode Timing Characteristics¹

Conditions are shown in [Table A-4](#) unless otherwise noted, C_{LOAD} = 200pF on all outputs

Num	C	Rating	Symbol	Min	Typ	Max	Unit
1	P	Operating Frequency	f _{op}	DC	—	1/4	f _{bus}
1	P	SCK Period t _{sck} = 1./f _{op}	t _{sck}	4	—	2048	t _{bus}
2	D	Enable Lead Time	t _{lead}	1/2	—	—	t _{sck}
3	D	Enable Lag Time	t _{lag}	1/2	—	—	t _{sck}
4	D	Clock (SCK) High or Low Time	t _{wsck}	t _{bus} - 30	—	1024 t _{bus}	ns
5	D	Data Setup Time (Inputs)	t _{su}	25	—	—	ns
6	D	Data Hold Time (Inputs)	t _{hi}	0	—	—	ns
9	D	Data Valid (after Enable Edge)	t _v	—	—	25	ns
10	D	Data Hold Time (Outputs)	t _{ho}	0	—	—	ns
11	D	Rise Time Inputs and Outputs	t _r	—	—	25	ns
12	D	Fall Time Inputs and Outputs	t _f	—	—	25	ns

NOTES:

- The numbers 7, 8 in the column labeled "Num" are missing. This has been done on purpose to be consistent between the Master and the Slave timing shown in [Table A-18](#).

A.6.2 Slave Mode

[Figure A-7](#) and [Figure A-8](#) illustrate the slave mode timing. Timing values are shown in [Table A-18](#).

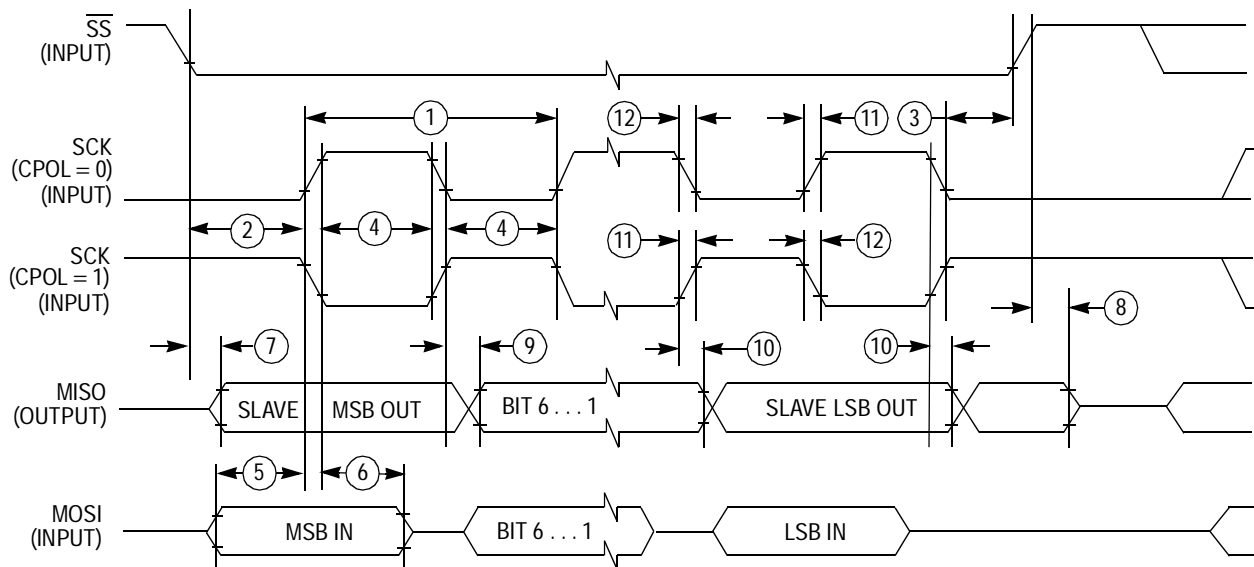

Figure A-7 SPI Slave Timing (CPHA = 0)

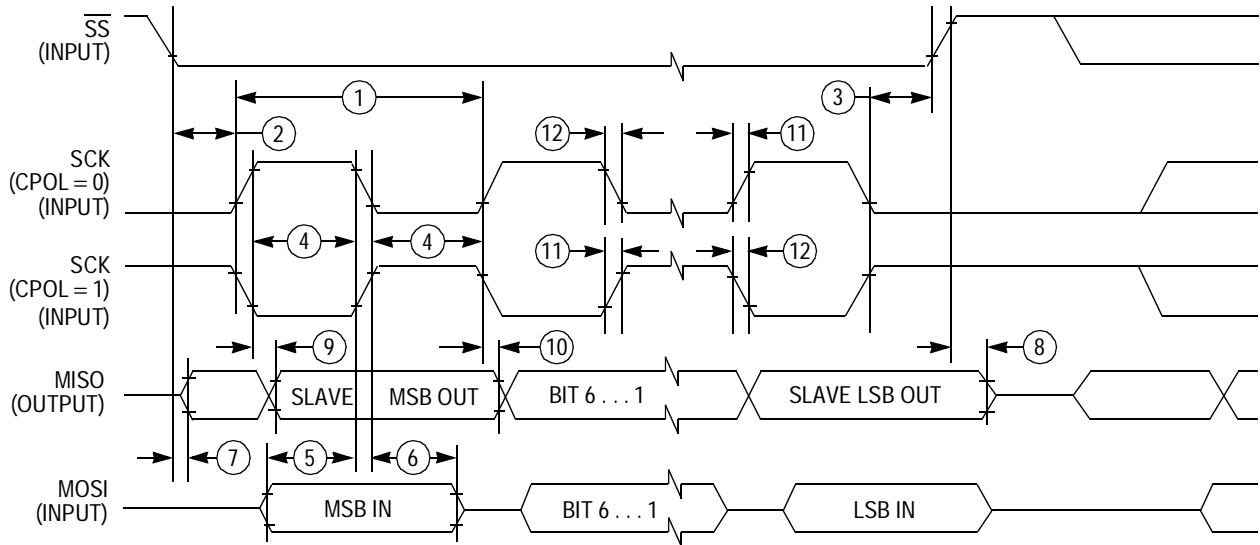

Figure A-8 SPI Slave Timing (CPHA =1)

Table A-18 SPI Slave Mode Timing Characteristics

Conditions are shown in [Table A-4](#) unless otherwise noted, CLOAD = 200pF on all outputs

Num	C	Rating	Symbol	Min	Typ	Max	Unit
1	P	Operating Frequency	f_{op}	DC	—	1/4	f_{bus}
1	P	SCK Period $t_{sck} = 1./f_{op}$	t_{sck}	4	—	2048	t_{bus}
2	D	Enable Lead Time	t_{lead}	1	—	—	t_{cyc}
3	D	Enable Lag Time	t_{lag}	1	—	—	t_{cyc}
4	D	Clock (SCK) High or Low Time	t_{wsck}	$t_{cyc} - 30$	—	—	ns
5	D	Data Setup Time (Inputs)	t_{su}	25	—	—	ns
6	D	Data Hold Time (Inputs)	t_{hi}	25	—	—	ns
7	D	Slave Access Time	t_a	—	—	1	t_{cyc}
8	D	Slave MISO Disable Time	t_{dis}	—	—	1	t_{cyc}
9	D	Data Valid (after SCK Edge)	t_v	—	—	25	ns
10	D	Data Hold Time (Outputs)	t_{ho}	0	—	—	ns
11	D	Rise Time Inputs and Outputs	t_r	—	—	25	ns
12	D	Fall Time Inputs and Outputs	t_f	—	—	25	ns

A.7 External Bus Timing

A timing diagram of the external multiplexed-bus is illustrated in [Figure A-9](#) with the actual timing values shown on table [Table A-19](#). All major bus signals are included in the diagram. While both a data write and data read cycle are shown, only one or the other would occur on a particular bus cycle.

A.7.1 General Muxed Bus Timing

The expanded bus timings are highly dependent on the load conditions. The timing parameters shown assume a balanced load across all outputs.

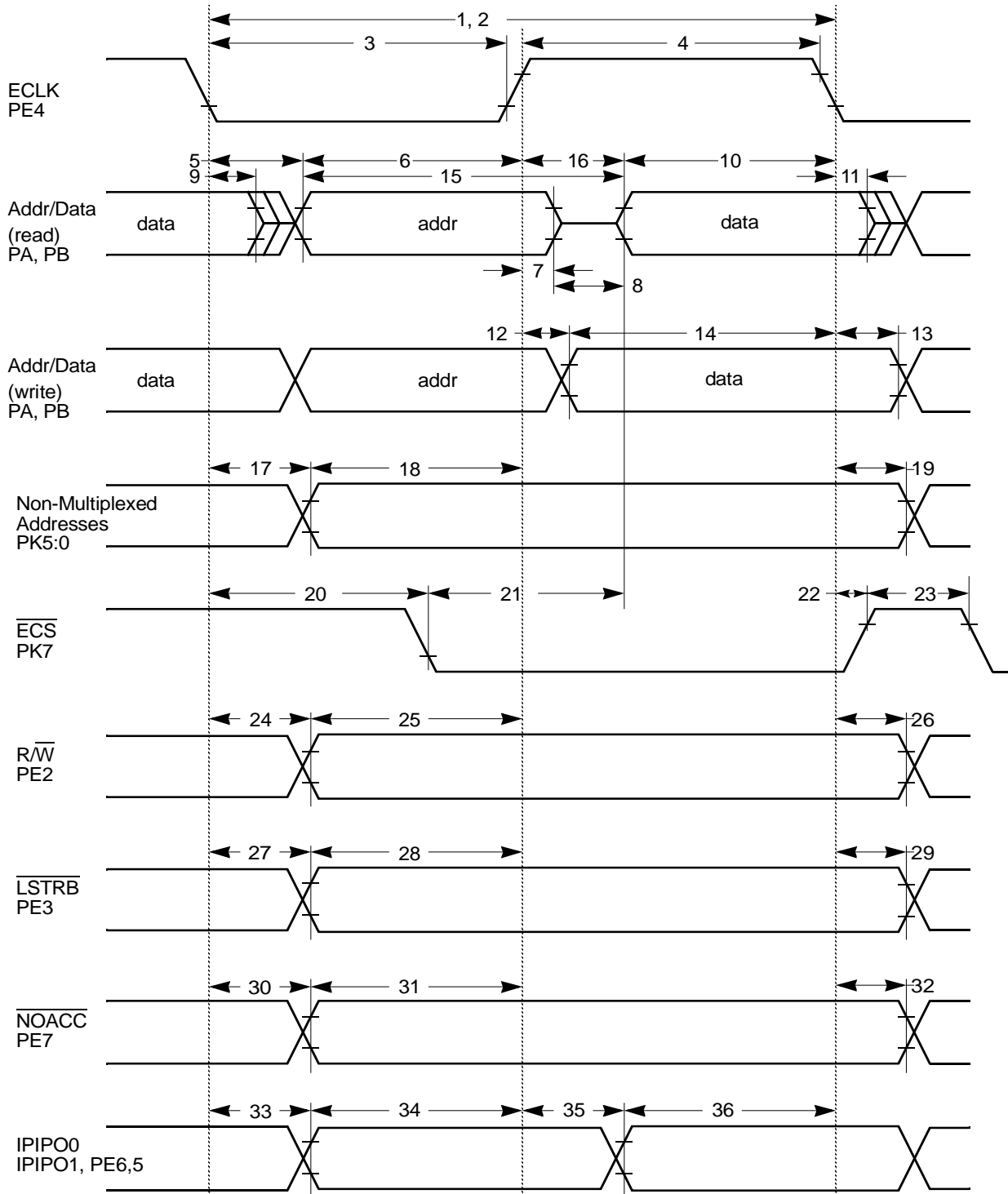

Figure A-9 General External Bus Timing

Table A-19 Expanded Bus Timing Characteristics

Conditions are shown in Table A-4 unless otherwise noted, $C_{LOAD} = 50\text{pF}$							
Num	C	Rating	Symbol	Min	Typ	Max	Unit
1	P	Frequency of operation (E-clock)	f_o	0	—	25.0	MHz
2	P	Cycle time	t_{cyc}	40	—	—	ns
3	D	Pulse width, E low	PW_{EL}	19	—	—	ns
4	D	Pulse width, E high ⁽¹⁾	PW_{EH}	19	—	—	ns
5	D	Address delay time	t_{AD}	—	—	8	ns
6	D	Address valid time to E rise ($PW_{EL}-t_{AD}$)	t_{AV}	11	—	—	ns
7	D	Muxed address hold time	t_{MAH}	2	—	—	ns
8	D	Address hold to data valid	t_{AHDS}	7	—	—	ns
9	D	Data hold to address	t_{DHA}	2	—	—	ns
10	D	Read data setup time	t_{DSR}	13	—	—	ns
11	D	Read data hold time	t_{DHR}	0	—	—	ns
12	D	Write data delay time	t_{DDW}	—	—	7	ns
13	D	Write data hold time	t_{DHW}	2	—	—	ns
14	D	Write data setup time ⁽¹⁾ ($PW_{EH}-t_{DDW}$)	t_{DSW}	12	—	—	ns
15	D	Address access time ⁽¹⁾ ($t_{cyc}-t_{AD}-t_{DSR}$)	t_{ACCA}	19	—	—	ns
16	D	E high access time ⁽¹⁾ ($PW_{EH}-t_{DSR}$)	t_{ACCE}	6	—	—	ns
17	D	Non-multiplexed address delay time	t_{NAD}	—	—	6	ns
18	D	Non-muxed address valid to E rise ($PW_{EL}-t_{NAD}$)	t_{NAV}	15	—	—	ns
19	D	Non-multiplexed address hold time	t_{NAH}	2	—	—	ns
20	D	Chip select delay time	t_{CSD}	—	—	16	ns
21	D	Chip select access time ⁽¹⁾ ($t_{cyc}-t_{CSD}-t_{DSR}$)	t_{ACCS}	11	—	—	ns
22	D	Chip select hold time	t_{CSH}	2	—	—	ns
23	D	Chip select negated time	t_{CSN}	8	—	—	ns
24	D	Read/write delay time	t_{RWD}	—	—	7	ns
25	D	Read/write valid time to E rise ($PW_{EL}-t_{RWD}$)	t_{RWV}	14	—	—	ns
26	D	Read/write hold time	t_{RWH}	2	—	—	ns
27	D	Low strobe delay time	t_{LSD}	—	—	7	ns
28	D	Low strobe valid time to E rise ($PW_{EL}-t_{LSD}$)	t_{LSV}	14	—	—	ns
29	D	Low strobe hold time	t_{LSH}	2	—	—	ns
30	D	NOACC strobe delay time	t_{NOD}	—	—	7	ns
31	D	NOACC valid time to E rise ($PW_{EL}-t_{NOD}$)	t_{NOV}	14	—	—	ns

Table A-19 Expanded Bus Timing Characteristics

Conditions are shown in Table A-4 unless otherwise noted, $C_{LOAD} = 50\text{pF}$							
Num	C	Rating	Symbol	Min	Typ	Max	Unit
32	D	NOACC hold time	t_{NOH}	2	—	—	ns
33	D	IPIPO[1:0] delay time	t_{P0D}	2	—	7	ns
34	D	IPIPO[1:0] valid time to E rise ($PW_{EL}-t_{P0D}$)	t_{P0V}	11	—	—	ns
35	D	IPIPO[1:0] delay time ¹ ($PW_{EH}-t_{P1V}$)	t_{P1D}	2	—	25	ns
36	D	IPIPO[1:0] valid time to E fall	t_{P1V}	11	—	—	ns

NOTES:

1. Affected by clock stretch: add $N \times t_{cyc}$ where $N=0,1,2$ or 3 , depending on the number of clock stretches.

Appendix B Package Information

B.1 General

This section provides the physical dimensions of the MC9S12A128 packages.

B.2 112-Pin LQFP Package

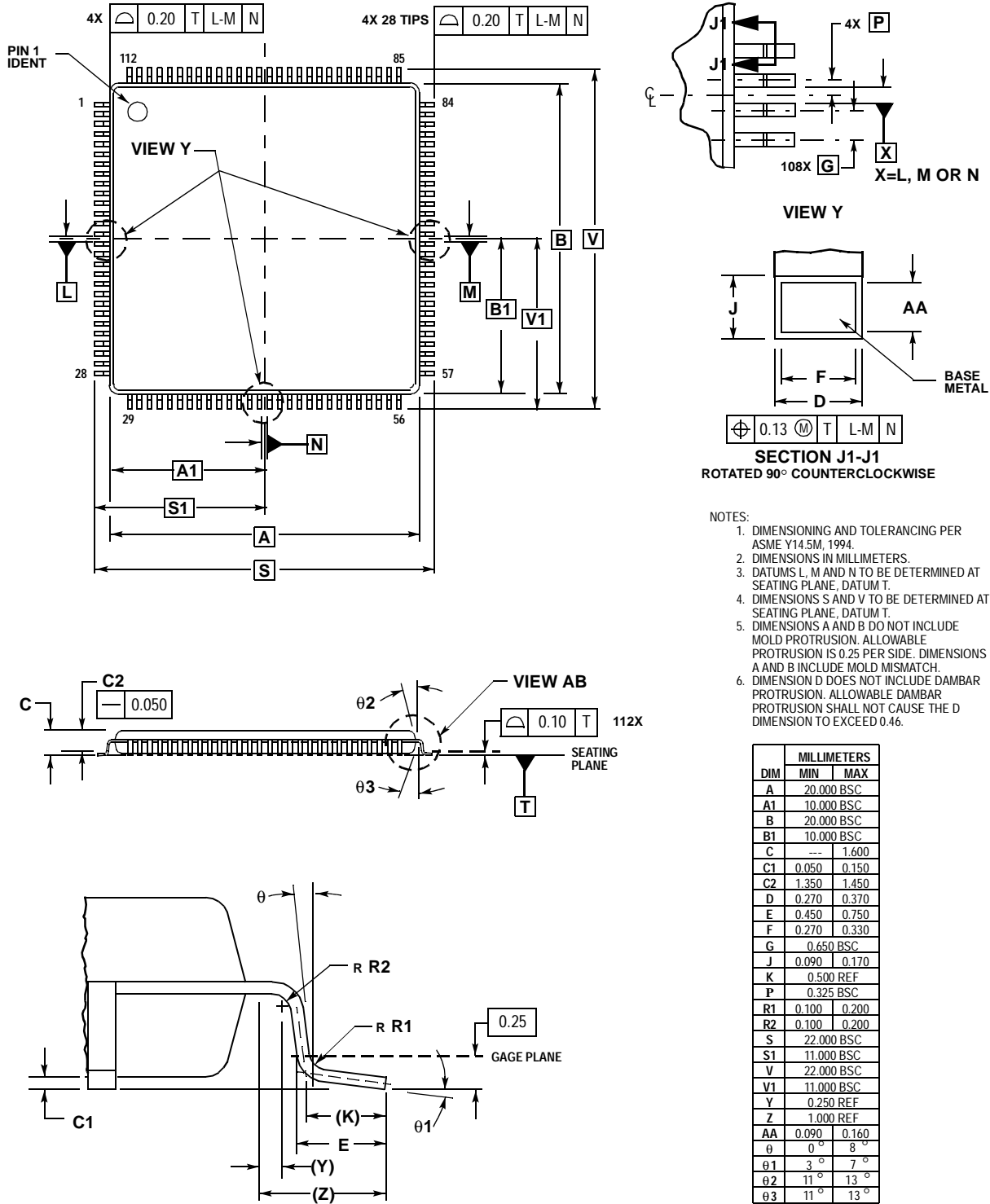

Figure B-1 112-Pin LQFP Mechanical Dimensions (Case no. 987)

B.3 80-Pin QFP Package

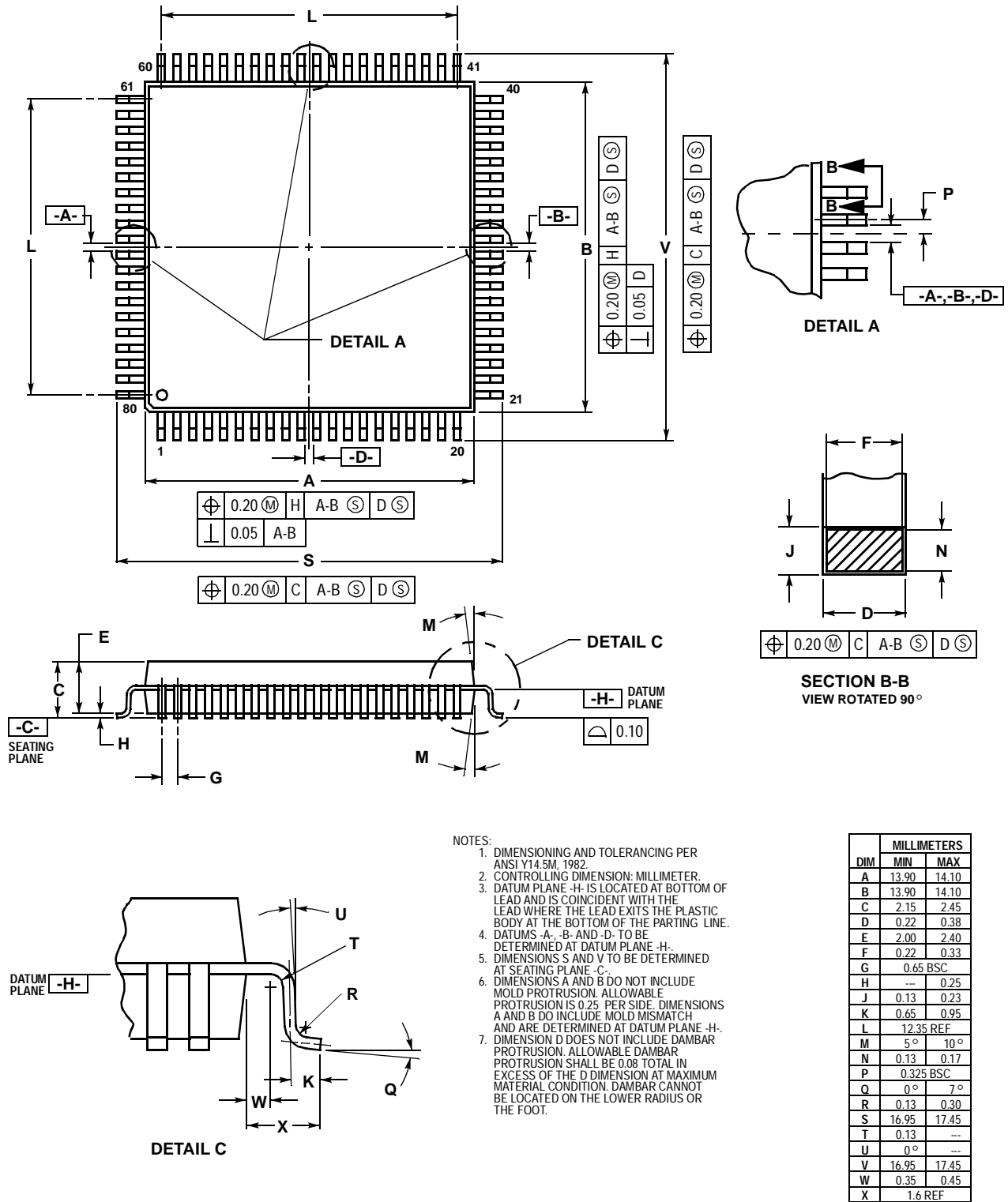

Figure B-2 80-pin QFP Mechanical Dimensions (Case no. 841B)

User Guide End Sheet

**FINAL PAGE OF
92
PAGES**