



**FEATURES**

- Low cost
- Diffused junction
- Ultra fast switching for high efficiency
- Low reverse leakage current
- Low forward voltage drop
- High current capability
- The plastic material carries UL recognition 94V-0

**MECHANICAL DATA**

Case Molded Plastic

Polarity: Indicated by cathode band

Weight: 0.002 ounces,0.064 grams

Mounting position: Any

DO-214AC(SMA)

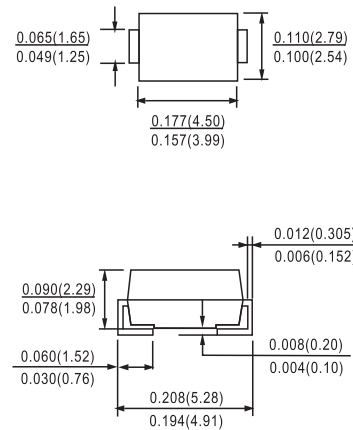

Dimensions in inches and (millimeters)

**MAXIMUM RATINGS AND ELECTRICAL CHARACTERISTICS**

Rating at 25 °C ambient temperature unless otherwise specified.  
 Single phase, half wave, 60 Hz, resistive or inductive load.  
 For capacitive load, derate current by 20%

Type Number	Symbol	HS 1A	HS 1B	HS 1D	HS 1F	HS 1G	HS 1J	HS 1K	HS 1M	Units
Maximum Recurrent Peak Reverse Voltage	V <sub>RRM</sub>	50	100	200	300	400	600	800	1000	V
Maximum RMS Voltage	V <sub>RMS</sub>	35	70	140	210	280	420	560	700	V
Maximum DC Blocking Voltage	V <sub>DC</sub>	50	100	200	300	400	600	800	1000	V
Maximum Average Forward Rectified Current See Fig.1	I <sub>F(AV)</sub>	1.0								A
Peak Forward Surge Current, 8.3 ms Single Half Sine-wave Superimposed on Rated Load (JEDEC method )	I <sub>FSM</sub>	30								A
Maximum Instantaneous Forward Voltage @ 1.0A	V <sub>F</sub>	1.0			1.3		1.7			V
Maximum D.C. Reverse Current at Rated DC Blocking Voltage (Note1)	I <sub>R</sub>	5.0				50				uA
		150								uA
Maximum Reverse Recovery Time ( Note4)	T <sub>rr</sub>	50				75				nS
Typical Junction Capacitance ( Note 2 )	C <sub>j</sub>	20				15				pF
Maximum Thermal Resistance (Note 3)	R <sub>θJA</sub>	70								°C/W
Operating Temperature Range	T <sub>J</sub>	-55 to +150								°C
Storage Temperature Range	T <sub>STG</sub>	-55 to +150								°C

- Notes: 1. Pulse Test with PW=300 usec, 1% Duty Cycle  
 2. Reverse Recovery Test Conditions: I<sub>F</sub>=0.5A, I<sub>R</sub>=1.0A, I<sub>RR</sub>=0.25A  
 3. Measured at 1 MHz and Applied V<sub>R</sub>=4.0 Volts.  
 4. Mounted on P.C.Board with 0.2" x 0.2" (5mm x 5mm) Copper Pad Area.

**RATINGS AND CHARACTERISTIC CURVES HS1A THRU HS1M**

FIG.1- REVERSE RECOVERY TIME CHARACTERISTIC AND TEST CIRCUIT DIAGRAM

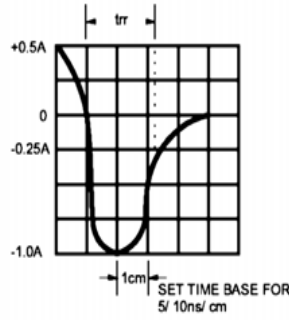
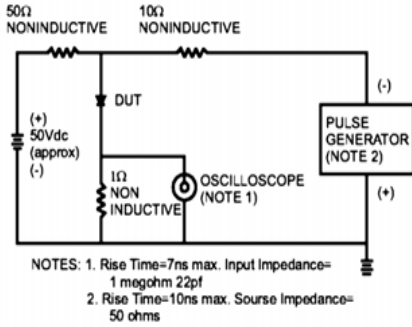

FIG.2- MAXIMUM AVERAGE FORWARD CURRENT DERATING

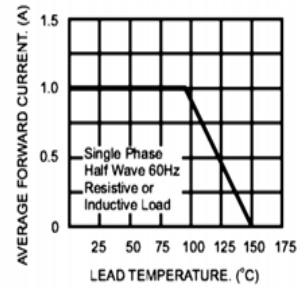

FIG.3- TYPICAL REVERSE CHARACTERISTICS

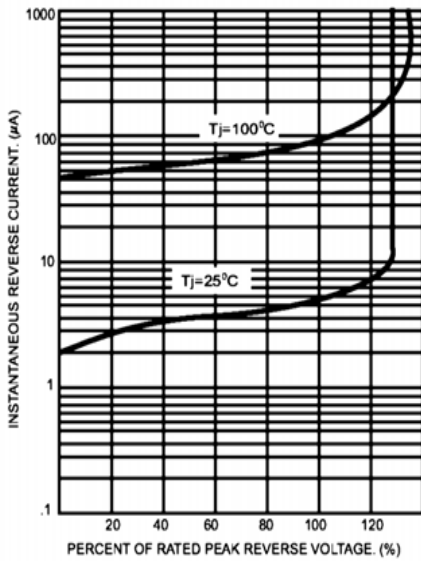

FIG.4- TYPICAL INSTANTANEOUS FORWARD CHARACTERISTICS

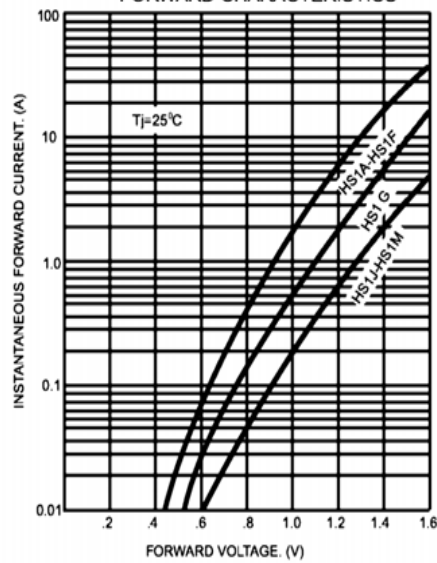

FIG.5- MAXIMUM NON-REPETITIVE FORWARD SURGE CURRENT

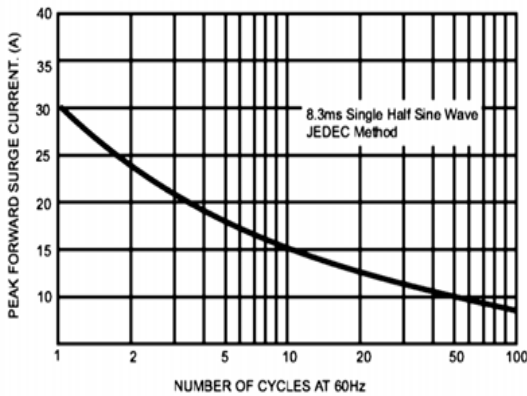

FIG.6- TYPICAL JUNCTION CAPACITANCE

